

**LOW VOLTAGE MONO/STEREO POWER AMPLIFIER**

**GENERAL DESCRIPTION**

The ILA7050 is a low voltage audio amplifier for small radios with headphones (such as watch, pen and pocket radios) in mono (bridge-tied load) or stereo applications.

**Features**

- Limited to battery supply application only (typ. 3 and 4 V)
- Operates with supply voltage down to 1,6 V
- No external components required
- Very low quiescent current
- Fixed integrated gain of 26 dB, floating differential input
- Flexibility in use - mono BTL as well as stereo
- Small dimension of encapsulation (see package design example)

**QUICK REFERENCE DATA**

Supply voltage range	Vp	1,6	to 6,0 V
Total quiescent current (at Vp = 3 V)	Itot	typ.	3,2 mA
Bridge tied load application (BTL)			
Output power at R) = 32 Ω			
Vp=3V; dtat=10%	PO	typ.	140 mW
D.C. output offset voltage between the outputs	IAMI	max.	70 mV
Noise output voltage (r.m.s. value)			
at f = 1 kHz; Rg = 5 kfit	Vno(rms)	typ.	140 mV
Stereo application			
Output power at R( = 32 Ω			
d <sub>tot</sub> = 10%; Vp = 3V	Po	typ.	35 mW
d <sub>tot</sub> = 10%; Vp= 4,5V	Po	typ.	75 mW
Channel separation at Rs = 0 Ω; f = 1 kHz	K	typ.	40 dB
Noise output voltage (r.m.s. value)			
at f = 1 kHz; Rs = 5 kΩ	Vno(rms)	typ.	100 mV

**PACKAGE OUTLINE** 8-lead DIL; plastic (SOT97); SOT97-1;

CHARACTERISTICS  $V_p = 3\text{ V}$ ;  $f = 1\text{ kHz}$ ;  $R_L = 32\ \Omega$ ,  $T_{amb} = 25\text{ }^\circ\text{C}$ ; unless otherwise specified

PARAMETER	SYMBOL	MIN.	TYP.	MAX.	UNIT
Supply					
Supply voltage	$V_p$	1,6	-	6,0	V
Total quiescent current	$I_{tot}$	-	3,2	4	mA
Bridge-tied load application (BTL); see Fig.4					
Output power; note 1					
$V_p = 3,0\text{ V}$ ; $d_{tot} = 10\%$	$P_o$	-	140	-	mW
$V_p = 4,5\text{ V}$ ; $d_{tot} = 10\%$ ( $R_L = 64\ \Omega$ )	$P_o$	-	150	-	mW
Voltage gain	$G_v$	-	32	-	dB
Noise output voltage (r.m.s. value)					
$R_s = 5\text{ k}\Omega$ ; $f = 1\text{ kHz}$	$V_{no(rms)}$	-	140	-	mV
$R_s = 0\ \Omega$ ; $f = 500\text{ kHz}$ ; $B = 5\text{ kHz}$	$V_{no(rms)}$	-	tbf	-	mV
D.C. output offset voltage (at $R_s = 5\text{ k}\Omega$ )	$I\Delta V_I$	-	-	70	mV
Input impedance (at $R_s = \infty$ )	$ Z_{iI} $	1	-	-	$M\Omega$
Input bias current	$i_i$	-	40	-	nA
Stereo application;					
Output power; note 1					
$V_p = 3,0\text{ V}$ ; $d_{tot} = 10\%$	$P_o$	-	35	-	mW
$V_p = 4,5\text{ V}$ ; $d_{tot} = 10\%$	$P_o$	-	75	-	mW
Voltage gain	$G_v$	24.5	26	27.5	dB
Noise output voltage (r.m.s. value)					
$R_s = 5\text{ k}\Omega$ ; $f = 1\text{ kHz}$	$V_{no(rms)}$	-	100	-	mV
$R_s = 0\ \Omega$ ; $f = 500\text{ kHz}$ ; $B = 5\text{ kHz}$	$V_{no(rms)}$	-	tbf	-	mV
Channel separation					
$R_s = 0\ \Omega$ ; $f = 1\text{ kHz}$	$K$	30	40	-	dB
Input impedance (at $R_s = \infty$ )	$ Z_{jI} $	2	-	-	$M\Omega$
Input bias current	$i_i$	-	20	-	nA

Note

1. Output power is measured directly at the output pins of the IC. It is shown as a function of the supply voltage in Fig.2 (BTL application) and Fig.3 (stereo application).

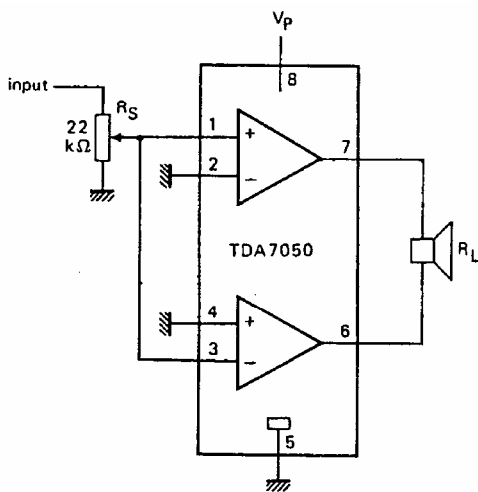

Application diagram (BTL)

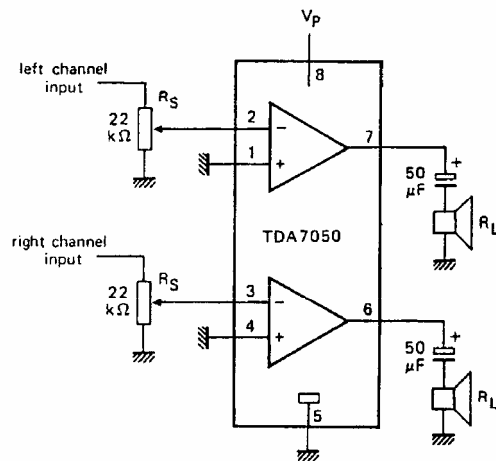

Application diagram (stereo)

**N SUFFIX PLASTIC DIP  
(MS - 001BA)**

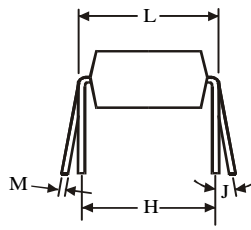
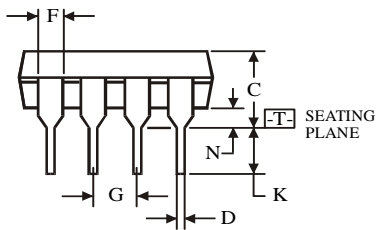
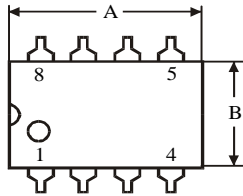
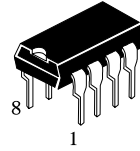

$\oplus 0.25 (0.010) \text{ M T}$

Symbol	Dimension, mm	
	MIN	MAX
A	8.51	10.16
B	6.1	7.11
C		5.33
D	0.36	0.56
F	1.14	1.78
G	2.54	
H	7.62	
J	0°	10°
K	2.92	3.81
L	7.62	8.26
M	0.2	0.36
N	0.38	

**NOTES:**

1. Dimensions “A”, “B” do not include mold flash or protrusions.

Maximum mold flash or protrusions 0.25 mm (0.010) per side.