

5W+5W AMPLIFIER WITH DC VOLUME CONTROL

ILA7496

DESCRIPTION

The ILA7496 is a stereo 5+5W class AB power amplifier assembled in the (DBS15), especially developed for high quality sound, TV applications. Features of the ILA7496 include linear volume control, "Stand-by" and "Mute" functions.

ILA7496 can be applied in sound processing circuits of consumer audio-devices & TV-sets. Both types of power supply (from 220V electrical network and battery) are available.

FEATURES

- 2 × 5 Output power $R_L = 8 \text{ Ohm}$, THD = 10% $U_S = 22 \text{ V}$;
- "Stand-by" & "Mute" modes;
- linear volume regulation;
- no external components on "stand-by" pin;
- Single supply up to 32 V;
- Short-circuit protection;
- Thermal overload protection;
- internally fixed gain;
- linear outputs (pins 02, 04) after volume control circuit (for earphones);
- power 15-pin package (DBS 15).

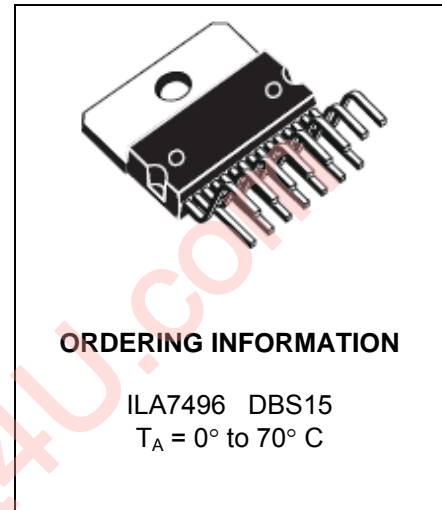

PIN CONNECTION (Top view)

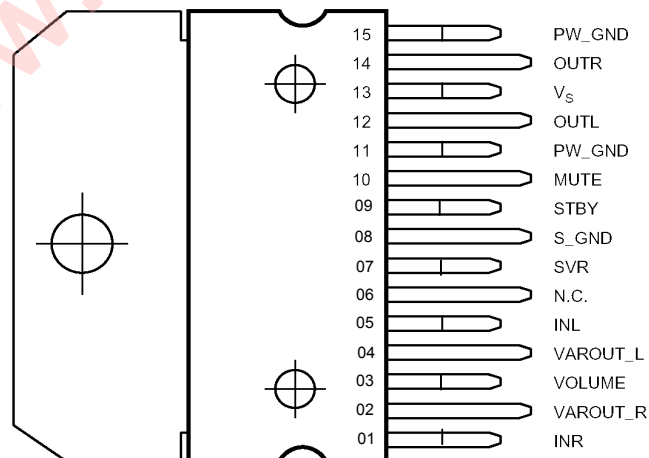

PIN DESCRIPTION

Pin number	Symbol	Description
01	INR	Input channel 1
02	VAROUT_R	Output channel 1 with volume regulation
03	VOLUME	Volume regulation input
04	VAROUT_L	Output channel 2 with volume regulation
05	INL	Input channel 2
06	NC	Not connected
07	SVR	Level control input
08	S_GND	GND (low current)
09	STBY	“Stand-by” mode pin
10	MUTE	“Mute” mode pin
11	PW_GND	GND (power)
12	OUTL	Output channel 2
13	V _s	Power supply pin
14	OUTR	Output channel 2
15	PW_GND	GND (power)

BLOCK DIAGRAM

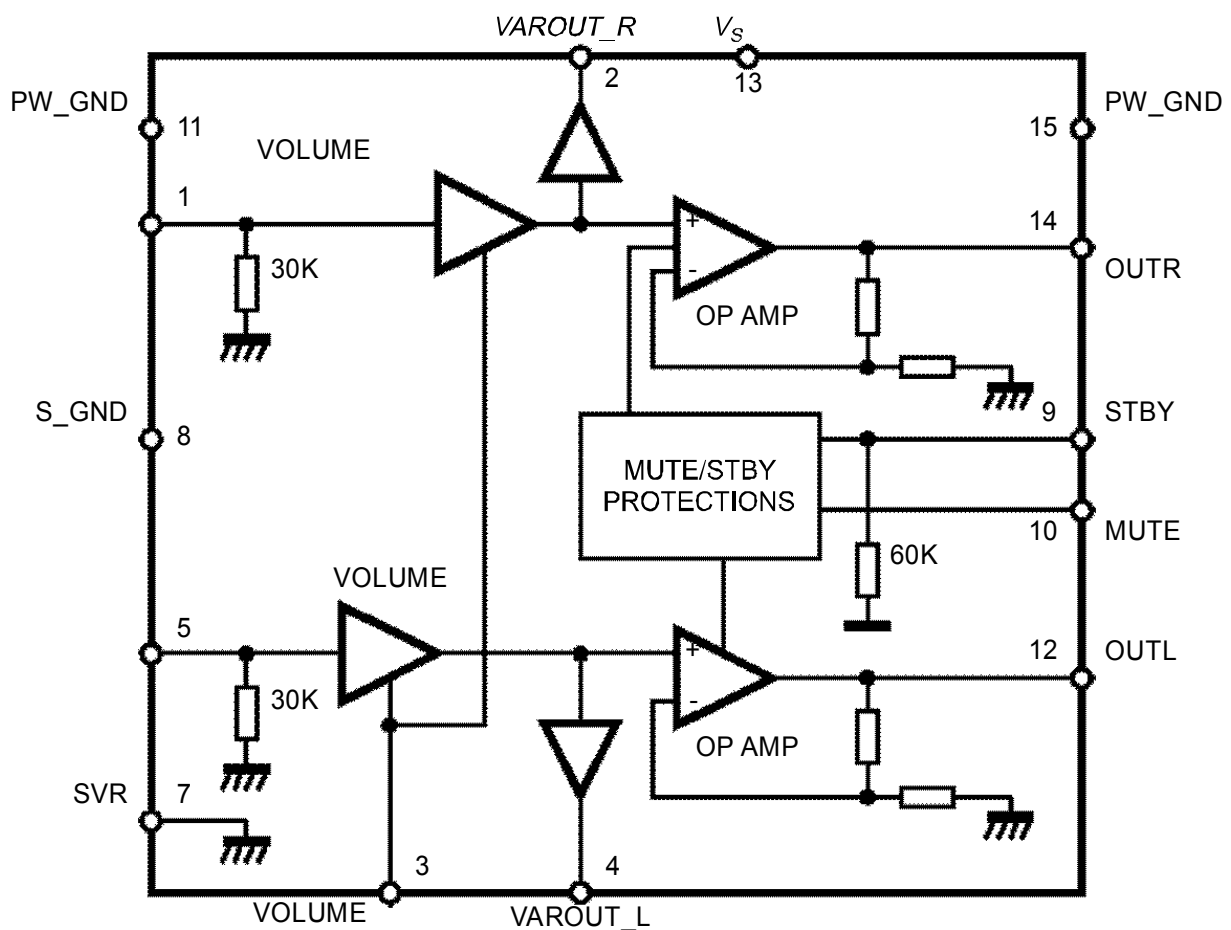

MANIMUM & ABSOLUTE MAXIMUM RATINGS

Parameter	Symbol	Maximum ratings		Absolute maximum ratings	
		Min	Max	Min	Max
DC Supply Voltage, V	U_S	10	32	-	35
Maximum Input Voltage, V	U_{IN}	-	-	-	8.0
Volume CTRL DC voltage (Pin03), V	U_{VOL}	-	5.0	-	7.0
Output peak current, A	I_{peak}	-	-	1.0 (internally limited)	-
Junction temperature, °C	T_J	-	150	-	151
Storage temperature, °C	T_{stg}	-	-	-40	150
Total power dissipation, W	P_{tot}	-	¹⁾	-	15 ²⁾

¹⁾ P_{tot} , W - power dissipation permitted for device at T_A , °C P_{tot} , W, is calculated by formula

$$P_{tot} = (T_J - T_A) / R_{th\ j-a} \quad (1)$$

T_J – increased maximum junction temperature, 150°C;

$R_{th\ j-a}$ - thermal resistance junction-air, °C/W, (for ICs without additional heat dissipators(radiators) 35 °C/W);

For ICs on external radiator,

$$R_{th\ j-a} = R_{th\ j-c} + R_{th\ c-r} + R_{th\ r-a} \quad (2)$$

$R_{th\ j-c}$ - thermal resistance junction-package 4 °C/W;

$R_{th\ c-r}$ - thermal resistance package-radiator, °C/W;

$R_{th\ r-a}$ - thermal resistance radiator-air, °C/W.

$R_{th\ c-r}$, $R_{th\ r-a}$ – is defined by radiator construction

²⁾ $T_A = 70^\circ\text{C}$, for ICs mounted on external radiator

ELECTRIC PARAMETERS

Parameter, unit	Symbol	Value		Mode	T _A , (°C)
		Min	Max		
Quiescent current, mA	I _q			U _S = 22 V. No input signal , C _{SVR} = 470 uF	25 ± 10 0 ± 3 70 ± 3
Quiescent current “stand-by” mode, mA	I _{qSTBY}			U _S = 22 V. No input signal C _{SVR} = 470 uF	
Output power, W	P _O	<u>5.0</u> 4.0	-	U _S = 22 V, THD = 10%, f _i = 1 kHz; R _L = 8 Ohm; C _{SVR} = 470 uF	
Total Harmonic Distortion, %	THD	-	<u>0.4</u> 0.6	U _S = 22 V, G _v = 30 dB, P _o = 1W, f _i = 1kHz, R _L = 8Ohm; C _{SVR} = 470uF	
Close loop gain, dB	G _v	<u>28.5</u> 28.0	<u>31.5</u> 32.0	U _S = 22 V, U _{VOL} > 4.5 V, R _L = 8 Ohm, f _i = 1kHz; C _{SVR} = 470 uF	
Monitor Out Gain	G _{vLine}	<u>-1.5</u> -1.6	<u>1.5</u> 1.6	U _S = 22 V, U _{VOL} > 4.5 V, f _i = 1 kHz , R _L > 30 kOhm C _{SVR} = 470 uF	
Slew Rate, V/us	SR	<u>5.0</u> 4.0	-	U _S = 22 V, R _L = 8 Ohm f _i = 1 kHz, Q = 2; C _{SVR} = 470 uF	
Input resistance, kOhm	R _i	<u>22.5</u> 17.0	-	U _S = 22 V, R _L = 8 Ohm, f _i = 1 kHz; C _{SVR} = 470 uF	
Stand-by mode threshold, V	U _{STBY}	<u>1.5</u> 1.3	<u>3.5</u> 3.7	U _S = 22 V, R _L = 8 Ohm; f _i = 1 kHz, C _{SVR} = 470 uF	
Mute mode threshold, V	U _{MUTE}	<u>1.5</u> 1.3	<u>3.5</u> 3.7	U _S = 22 V, R _L = 8 Ohm; f _i = 1 kHz, C _{SVR} = 470 uF	
Volume level attenuation, dB	A _{MIN VOL}	<u>80</u> 70	-	U _S = 22 V, U _{VOL} < 0.5 V, R _L = 8 Ohm, f _i = 1 kHz; C _{SVR} = 470 uF	
Mute Attenuation, dB	A _{MUTE}	<u>50</u> 45	-	U _S = 22 V, R _L = 8 Ohm; C _{SVR} = 470 uF	
Stand-by bias current, uA	I _{stbyBIAS}	<u>-20</u> -25	-	U _S = 22 V, R _L = 8 Ohm No input signal. Stand-by or play mode	

ELECTRIC PARAMETERS (continued)

Parameter, unit	Symbol	Value		Mode	T _A , °C
		Min	Max		
Mute bias current, uA	I _{muteBIAS}	-	<u>5.0</u> 8.0	U _s = 22 V, R _L = 8 Ohm No input signal. "Mute" mode	<u>25 ± 10</u> 0 ± 3 70 ± 3
		-	<u>2.0</u> 5.0	"Play" mode	
Total Output Noise, uV	e _N	-	<u>800</u> 1200	U _s = 22 V, R _L = 8 Ohm; f = 20 Hz-22 kHz, C _{SVR} = 470 uF. No input signal "Play" mode, max volume	
		-	<u>250</u> 375	U _s = 22 V, R _L = 8 Ohm; f = 20 Hz-22 kHz, C _{SVR} = 470 uF. No input signal "Play" mode, max attenuation	
		-	<u>150</u> 225	U _s = 22 V, R _L = 8 Ohm; f = 20 Hz-22 kHz, C _{SVR} = 470 uF. No input signal, "Mute" mode	
Variable Output Resistance, Ohm	R _{Var Out}	-	<u>100</u> 120	U _s = 22 V, f _i = 1 kHz; C _{SVR} = 470 uF; C _{VAROUT} = 1000 uF; R _{VAROUT} = 30 Ohm	
Supply Voltage Rejection, dB	SVR	<u>35</u> 30	-	U _s = 22 V + U _{RIP} , U _{RIP} = 1 V (rms), f _i = 1 kHz, C _{SVR} = 470 uF, R _L = 8 Ohm Max volume	
		<u>55</u> 50	-	Max attenuation	

Note:

1 Minus means only outside direction of current

2 Designations:

- U_S – Supply voltage, Pin 13 (V_S);- U_{VOL} – Voltage applied to Pin 03 (VOLUME), or to resistor 300 kOhm, connected to pin 03 and voltage source;- R_L – resistor connected to pin 12 (OUTL), 14 (OUTR) and pin "GND";- C_{SVR} – Capacitor connected to pin 07 (SVR) and pin "GND";- C_{VAROUT} - Capacitor connected to pin 02 (VAROUT_R), 04 (VAROUT_L) and pin "GND";- R_{VAROUT} - resistor connected to pin 02 (VAROUT_R), 04 (VAROUT_L) and pin "GND";- U_{RIP} – amplitude of sine-form modulation signal3 Output resistance of alternate signal source (generator) R_G = 50 Ohm

Typical Values of Electric Parameters ($T_A = 25\text{ }^\circ\text{C}$)

Parameter	Unit	Symbol	Mode	Typical value
Output power	W	P_O	$U_S = 22\text{ V}$, THD = 1%, $R_L = 8\text{ Ohm}$; $C_{SVR} = 470\text{ uF}$; $f_i = 1\text{ kHz}$; $U_{VOL} = 5\text{ V}$; $U_{STBY} = U_{MUTE} = 0\text{ V}$	4
			$U_S = 12\text{ V}$, THD = 10%, $R_L = 4\text{ Ohm}$; $C_{SVR} = 470\text{ uF}$; $f_i = 1\text{ kHz}$; $U_{VOL} = 5\text{ V}$; $U_{STBY} = U_{MUTE} = 0\text{ V}$	2.1
			$U_S = 12\text{ V}$, THD = 1%, $R_L = 4\text{ Ohm}$; $C_{SVR} = 470\text{ uF}$; $f_i = 1\text{ kHz}$; $U_{VOL} = 5\text{ V}$; $U_{STBY} = U_{MUTE} = 0\text{ V}$	1.0
Band width	mHz	BW	$U_S = 22\text{ V}$, $R_L = 8\text{ Ohm}$; $C_{SVR} = 470\text{ uF}$; $U_{VOL} = 5\text{ V}$; $U_{STBY} = U_{MUTE} = 0\text{ V}$; $U_I = U_{SIN}$ ($f_i = 1\text{ kHz}$; $U_{ампл.} = 50\text{ mV}$)	0.6
Bias output voltage on SVR control	mV	DCU_{os}	$U_S = 22\text{ V}$. No input signal. $U_{VOL} = 5\text{ V}$; $U_{STBY} = U_{MUTE} = 0\text{ V}$	200
Stand-by output voltage	V	U_{oq}	$U_S = 22\text{ V}$ No input signal. $U_{VOL} = 5\text{ V}$; $U_{STBY} = U_{MUTE} = 0\text{ V}$	11
Stand-by bias current	μA	$I_{stbyBIAS}$	$U_S = 22\text{ V}$, $R_L = 8\text{ Ohm}$; $U_{VOL} = 5\text{ V}$; $C_{SVR} = 470\text{ uF}$ "Stand-by" mode, $U_{STBY} = 5\text{ V}$, $U_{MUTE} = 5\text{ V}$	80
Thermal Muting	$^\circ\text{C}$	T_M	$U_S = 22\text{ V}$; $f = 1\text{ kHz}$, $R_L = 8\text{ Ohm}$; $C_{SVR} = 470\text{ uF}$;	150
Thermal Shut-down	$^\circ\text{C}$	T_S	$U_{VOL} = 5\text{ V}$; $U_{STBY} = U_{MUTE} = 0\text{ V}$	160

Truth-Table

MUTE (Pin 10)	ST-BY (Pin 09)	OPERATING CONDITION
H	H	STANDBY
L	H	STANDBY
H	L	MUTE
L	L	PLAY

Note:

- H – high level; L – low level.
- It is permitted to shunt pin 09 ("Stand-by mode" pin) to GND for simplified application with mute function only.
- It is recommended for ON/OFF play mode to observe following conditions:
 - On switch-ON, if voltage level on pin 07 (SVR) is higher then 2,5V, IC must change mode from "Mute" to "Play";
 - On switch-OFF, if voltage level on pin 07 (SVR) is higher then 2,5V, IC must change mode from IC must change mode from "Play" to "Mute".

Application Circuit.

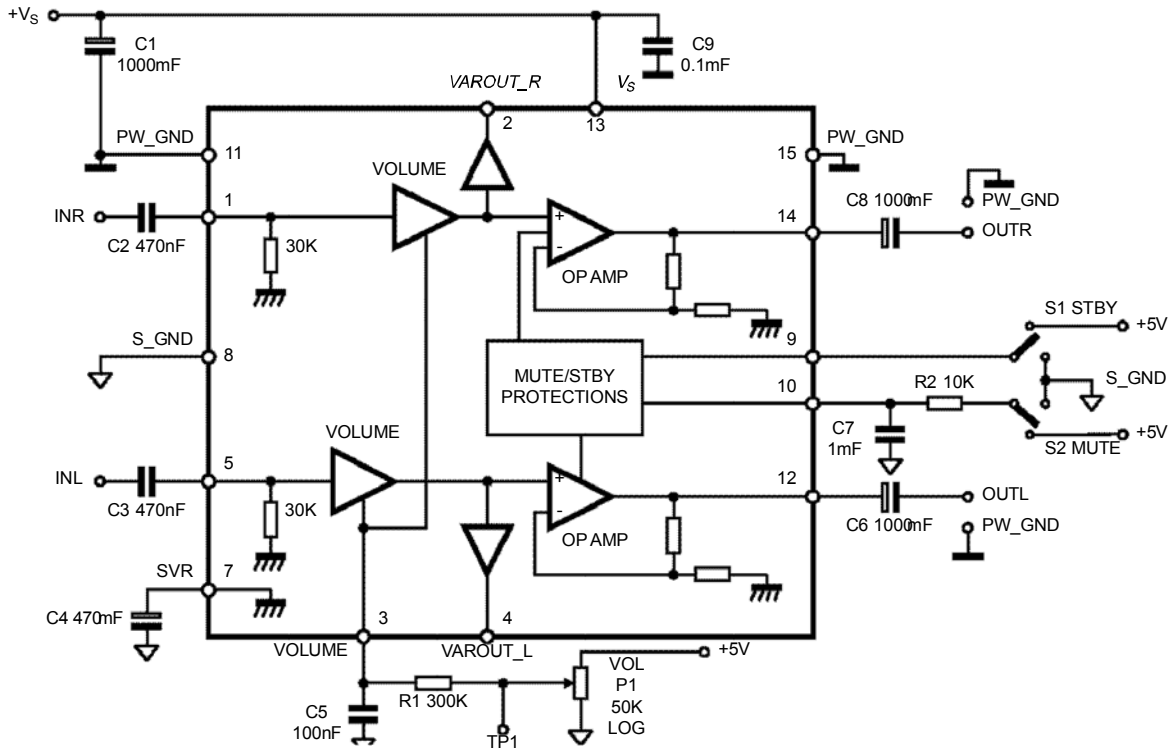

APPLICATION SUGGESTIONS

The recommended values of the external components are those shown on the application circuit of figure 1a. Different values can be used, the following table can help the designer.

COMPONENT	SUGGESTION		LARGER THAN SUGGESTION	SMALLER THAN SUGGESTION
	VALUE	PURPOSE		
R1	300K	Volume control circuit	Larger volume regulation time	Smaller volume regulation time
R2	10K	Mute time constant	Larger mute on/off time	Smaller mute on/off time
P1	50K	Volume control circuit		
C1	1000uF	Supply voltage bypass		Danger of oscillation
C2	470nF	Input DC decoupling	Lower low frequency cutoff	Higher low frequency cutoff
C3	470nF	Input DC decoupling	Lower low frequency cutoff	Higher low frequency cutoff
C4	470uF	Ripple rejection	Better SVR	Worse SVR
C5	100nF	Volume control time constant	Larger volume regulation time	Smaller volume regulation time
C6	1000uF	Output DC decoupling	Lower low frequency cutoff	Higher low frequency cutoff
C7	1uF	Mute time constant	Larger mute on/off time	Smaller mute on/off time
C8	1000uF	Output DC decoupling	Lower low frequency cutoff	Higher low frequency cutoff
C9	100nF	Supply voltage bypass		Danger of oscillation

Turn ON/OFF Sequences (for optimizing the POP performances)

A) USING MUTE AND STAND-BY FUNCTIONS

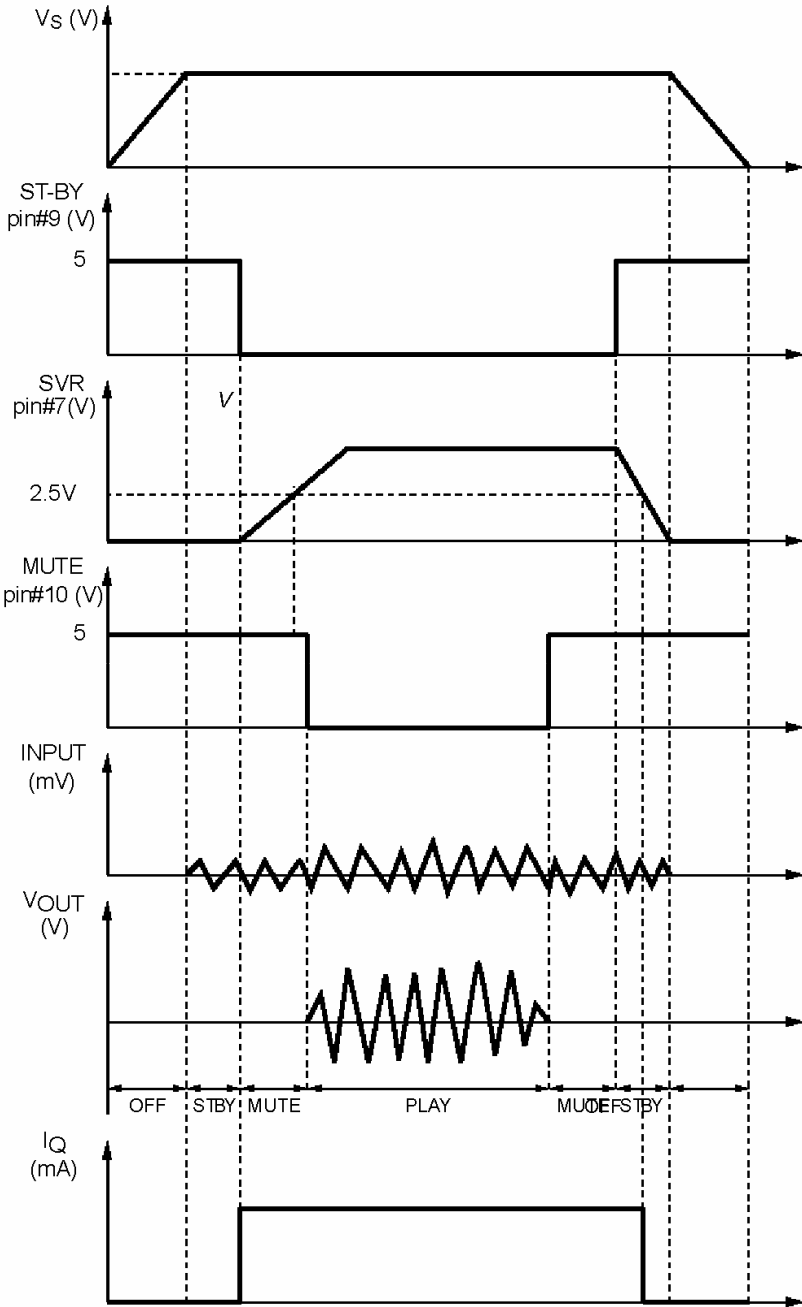

B) USING ONLY THE MUTE FUNCTION

To simplify the application, the stand-by pin can be connected directly to Ground. During the ON/OFF transitions it is recommended to respect the following conditions.

- At the turn-on, the transition mute - play must be made when the SVR pin is higher than 2.5V
- At the turn-off, the ILA7496 must be brought to mute from the play condition when the SVR pin is higher than 2.5V.

DBS15 PACKAGE DIMENSIONAL DATA

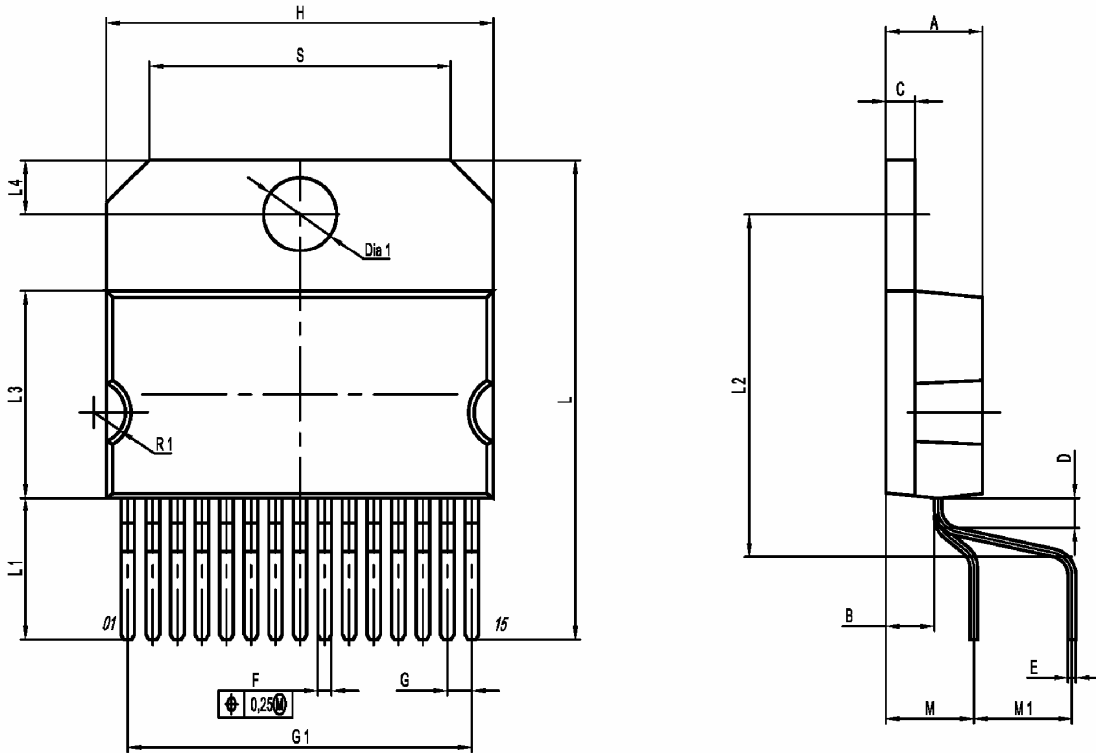

	A	B	C	D	E	F	G	G1	H	L	L1	L2	L3	L4	M	M1	S	Dia1	R1
Millimeters																			
MIN	-	2.5	1.45	1.475	0.38	0.65	-	-	-	24.64	7.2	17.54	10.7	2.73	-	-	15.35	3.8	1.38
MAX	5.0	2.7	1.55	1.725	0.48	0.75	1.27	17.78	20.2	25.16	7.6	18.06	10.85	2.87	4.55	5.08	15.85	3.875	1.88
Inches																			
MIN	-	0.098	0.057	0.058	0.015	0.026	-	-	-	0.970	0.284	0.691	0.421	0.108	-	-	0.604	0.150	0.054
MAX	0.197	0.106	0.061	0.068	0.019	0.030	0.05	0.7	0.795	0.991	0.299	0.711	0.427	0.113	0.179	0.2	0.624	0.153	0.074