

# ILC6370/6371

## Super Small Switching Regulator with Shutdown

### Features

- 85% efficiency at 50mA
- 900mV Start-up voltage
- $\pm 2.5\%$  output accuracy
- Only 3 external components required
- 50, 100 and 180kHz versions available
- 0.5 $\mu$ A supply current in shutdown mode
- External transistor option supports up to 1A load currents

### Applications

- Cellular Phones, Pagers
- Portable Cameras and Video Recorders
- Palmtops and PDAs
- Battery Powered Systems

### Description

The ILC6370 is a compact 50mA boost converter offered in a 5-lead SOT-89 package. Only three external components are needed to complete the switcher design, and frequency options of 50, 100, and 180kHz give the designer the ability to accommodate a wide range of system objectives, including size, electromagnetic interference requirements and so on. 87% max duty cycle gives conversion efficiencies of 85%.

Standard voltage options of 2.5V, 3.3V, and 5.0V at  $\pm 2.5\%$  accuracy feature on-chip phase compensation and soft-start design.

The ILC6371 is designed to drive an external transistor for high current switching regulators applications with all the features and benefits of the ILC6370 retained.

### Block Diagram

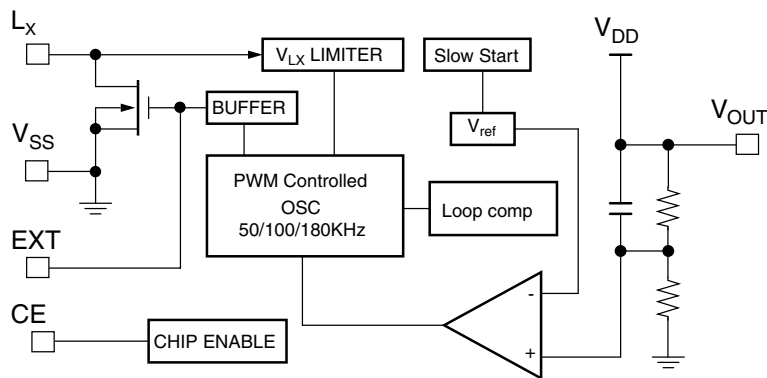

*V<sub>DD</sub> is internally connected to the V<sub>OUT</sub> pin.*

## Pin Assignments

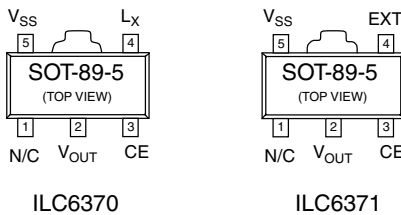

## Absolute Maximum Ratings $T_A = 25^\circ\text{C}$ , unless otherwise stated

Parameter	Symbol	Ratings	Units
$V_{OUT}$ Input Voltage Pin	$V_{OUT}$	12	V
CE Input Voltage	$V_{CE}$	12	V
Voltage on pin LX	$V_{LX}$	12	V
Current on pin LX	$I_{LX}$	400	mA
Voltage on pin EXT	$V_{EXT}$	$0.3 \sim V_{OUT} + 0.3$	V
Current pin EXT	$I_{EXT}$	$\pm 50$	mA
Continuous Total Power Dissipation (SOT-89-5)	$P_D$	500	mW
Operating Ambient Temperature	$T_{opr}$	$-40 \sim +85$	$^\circ\text{C}$
Storage Temperature	$T_{stg}$	$-40 \sim +125$	$^\circ\text{C}$

## Electrical Characteristics ILC6370BP-50

Unless otherwise specified  $V_{OUT} = V_{EN} = 5\text{V}$ ,  $V_{IN} = 0.6 \times V_{OUT}$ ,  $I_{OUT} = 50\text{mA}$ ,  $F_{OSC} = 100\text{kHz}$ ,  $T_A = 25^\circ\text{C}$ , Test Circuit Figure 1.

Parameter	Symbol	Conditions	Min.	Typ.	Max.	Units
Output Voltage	$V_{OUT}$		4.875	5.0	5.125	V
Input Voltage	$V_{IN}$				10	V
Oscillation Startup Voltage	$V_{ST1}$	No external components. Apply voltage to $V_{OUT}$ . Lx: 10k $\Omega$ pull-up to 5V			0.8	V
Operation Startup Voltage	$V_{ST2}$	External components connected. $I_{OUT} = 1\text{mA}$			0.9	V
Supply Current 1	$I_{DD1}$	Same as $V_{ST1}$ . Apply $V_{OUT} = 4.75\text{V}$		80.2	133.8	$\mu\text{A}$
Supply Current 2	$I_{DD2}$	Same as $V_{ST1}$ . $V_{OUT} = 5.5\text{V}$		8.2	16.5	$\mu\text{A}$
LX Switch-On Resistance	$R_{SWON}$	Same as $I_{DD1}$ . $V_{LX} = 0.4\text{V}$		1.4	2.4	$\Omega$
LX Leakage Current	$I_{LXL}$	No external components. $V_{OUT} = V_{LX} = 10\text{V}$			1.0	$\mu\text{A}$
Oscillator Frequency	$F_{OSC}$	Same as $I_{DD1}$ .	85	100	115	kHz
Maximum Duty Ratio	MAXDTY	Same as $I_{DD1}$ .	80	87	92	%
Stand-by Current	$I_{STB}$	Same as $I_{DD1}$ .			0.5	$\mu\text{A}$
CE "High" Voltage	$V_{CEH}$	Same as $I_{DD1}$ . Existence of Lx oscillation	0.75			V
CE "Low" Voltage	$V_{CEL}$	Same as $I_{DD1}$ . Disappearance of Lx oscillation			0.2	V
CE "High" Current	$I_{CEH}$	Same as $I_{DD1}$ . $V_{CE} = 4.75\text{V}$			0.25	$\mu\text{A}$
CE "Low" Current	$I_{CEL}$	Same as $I_{DD1}$ . $V_{CE} = 0\text{V}$			-0.25	$\mu\text{A}$
Efficiency	EFF			85		%
Slow Start Time	$T_{SS}$		4.0	10.0	20.0	mS

## Electrical Characteristics ILC6371BP-50

Unless otherwise specified  $V_{OUT} = V_{EN} = 5V$ ,  $V_{IN} = 0.6 \times V_{OUT}$ ,  $I_{OUT} = 50mA$ ,  $F_{OSC} = 100\text{ kHz}$ ,  $T_A = 25^\circ C$ ,  
Test Circuit Figure 2.

Parameter	Symbol	Conditions	Min.	Typ.	Max.	Units
Output Voltage	$V_{OUT}$		4.875	5.0	5.125	V
Input Voltage	$V_{IN}$				10	V
Oscillation Startup Voltage	$V_{ST1}$	No external components. Apply voltage to $V_{OUT}$ .			0.8	V
Operation Startup Voltage	$V_{ST2}$	External components connected. $I_{OUT} = 1mA$			0.9	V
Supply Current 1	$I_{DD1}$	Same as $V_{ST1}$ . Apply $V_{OUT} = 4.75V$		40.0	66.8	$\mu A$
Supply Current 2	$I_{DD2}$	Same as $V_{ST1}$ . $V_{OUT} = 5.5V$		8.2	16.5	$\mu A$
EXT "High" On Resistance	$R_{EXTH}$	Same as $I_{DD1}$ . $V_{EXT} = 0.4V$		37.5	62.5	$\Omega$
EXT "Low" On Resistance	$R_{EXTL}$	Same as $I_{DD1}$ . $V_{EXT} = 0.4V$		30	50	$\Omega$
Oscillator Frequency	$F_{OSC}$	Same as $I_{DD1}$ .	85	100	115	kHz
Maximum Duty Ratio	MAXDTY	Same as $I_{DD1}$ .	80	87	92	%
Stand-by Current	$I_{STB}$	Same as $I_{DD1}$ .			0.5	$\mu A$
CE "High" Voltage	$V_{CEH}$	Same as $I_{DD1}$ . Existence of Lx oscillation	0.75			V
CE "Low" Voltage	$V_{CEL}$	Same as $I_{DD1}$ . Disappearance of Lx oscillation			0.2	V
CE "High" Current	$I_{CEH}$	Same as $I_{DD1}$ . $V_{CE} = 4.75V$			0.25	$\mu A$
CE "Low" Current	$I_{CEL}$	Same as $I_{DD1}$ . $V_{CE} = 0V$			-0.25	$\mu A$
Efficiency	EFF			85		%
Slow Start Time	$T_{SS}$		4.0	10.0	20.0	mS

## Applications Circuits

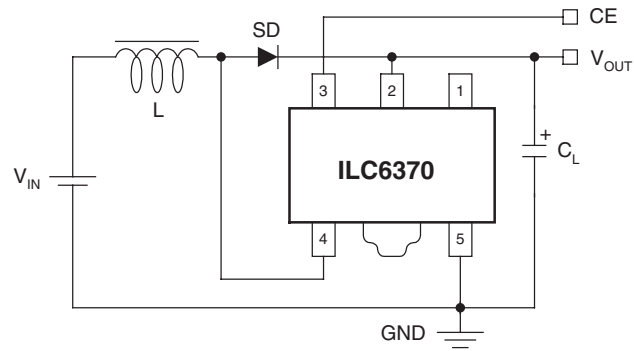

L: 100 $\mu$ H  
 SD: Schottky diode  
 $C_L$ : 47 $\mu$ F 16V (Ceramic or Tantalum Capacitor)

Figure 1. Test Circuit

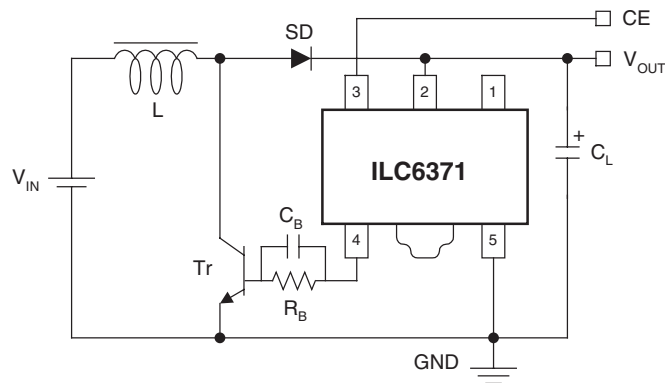

L: 100 $\mu$ H  
 SD: Schottky diode  
 $C_L$ : 47 $\mu$ F 16V (Ceramic or Tantalum Capacitor)  
 $R_B$ : 1k $\Omega$   
 $C_B$ : 3300pF  
 Tr: 2SC3279, 2SD1628G

Figure 2. Test Circuit

## Functions and Operation

The ILC6370 performs boost DC-DC conversion by controlling the switch element shown in the circuit below.

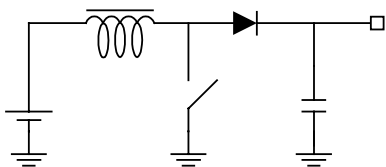

When the switch is closed, energy is built up in the inductor. When the switch opens, this energy is forced to pass through the diode to the output. As the on and off cycles continue, the output capacitor voltage builds up due to energy being transferred from the inductor.

Consequently, the output voltage is boosted with respect to input. The ILC6370/6371 monitors the voltage on the output capacitor in order to determine how much energy should be transferred through the switch.

In general, the switching characteristic is determined by the desired output voltage and the required load current. Specifically, the energy transfer is determined by the energy stored in the coil during each switching cycle.

$$EL = f(t_{ON}, V_{IN})$$

where EL is the energy stored in the inductor,  $t_{ON}$  is the ON time and  $V_{IN}$  is the input voltage.

The ILC6370/6371 use a Pulse Width Modulation (PWM) technique. The devices are offered with one of three fixed internal frequencies: 50, 100, or 180kHz. The switches are continuously driven at these frequencies. The control circuitry varies the power being delivered to the load by varying the on-time, or duty cycle, of the switch. Since more on-time translates to higher energy built up in the inductor, the maximum duty cycle of the switch determines the maximum load current that the device can support. The ILC6370 and ILC6371 both support up to 87% duty cycles, for maximum usable range of load currents. The internal bias ( $V_{OD}$ ) is provided by the output voltage  $V_{OUT}$ .

There are two key advantages of PWM type controllers. First, because the controller automatically varies the duty cycle of the switch's on-time in response to changing load conditions, the PWM controller will always have an optimized waveform for a steady-state load. This translates to very good efficiency at high currents and minimal ripple on the output. *[Ripple is due to the output capacitor constantly accepting and storing the charge received from the inductor, and delivering charge as required by the load. The "pumping" action of the switch produces a sawtooth-shaped voltage as seen at the output.]*

The other key advantage of the PWM type controllers is that the radiated noise due to the switching transients will always occur at a fixed switching frequency. Many applications are insensitive to switching noise, but certain types of applications, especially communication equipment, need to minimize the high frequency interference within their system as much as is possible. Using a boost converter requires a certain amount of high frequency noise to be generated; using a PWM converter makes that noise spectrum predictable; thus it is easier to filter it.

There are downsides of PWM approaches, especially at very low currents. Since the PWM techniques rely on constant switching and varying duty cycle to match the load conditions, there is a minimum load current that can be handled efficiently. If the ILC6370/6371 had an ideal switch, this would not be such a problem. But an actual switch consumes some finite amount of current to switch on and off; at very low current this can be of the same magnitude as the load current itself, driving switching efficiencies down to 50% and below.

The other limitation of PWM techniques is that, while the fundamental switching frequency is easier to filter out since it's constant, the higher order harmonics of PWM will be present and may have to be filtered out as well. Filtering requirements will vary by application and by actual system design and layout, so generalization in this area is difficult, at best. *[For other boost converter techniques, please refer to the ILC6380/81 and ILC6390/91 data sheets.]* Nevertheless, PWM control for boost DC-DC conversion is widely used, especially in audio-noise sensitive applications or applications requiring strict filtering of the high frequency components. Fairchild's products give very good efficiencies of 85% at 50mA output (5V operation), 87% maximum duty cycles for high load conditions, while maintaining very low shutdown current levels of 0.5 $\mu$ A. The only difference between the ILC6370 and ILC6371 parts is that the 6371 is configured to drive an external transistor as the switch element. Since larger transistors can be selected for this element, higher effective loads can be regulated.

### Start-up Mode

The ILC6370 has an internal soft-start mode which suppresses ringing or overshoot on the output during start-up. The following diagram illustrates this start-up condition's typical performance.

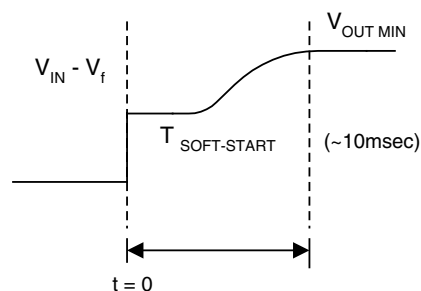

## External Components and Layout Consideration

The ILC6370 is designed to provide a complete DC-DC convertor solution with a minimum of external components. Ideally, only three externals are required: the inductor, a pass diode, and an output capacitor.

The inductor needs to be of low DC Resistance type, typically  $1\Omega$  value. Toroidal wound inductors have better field containment (less high frequency noise radiated out) but tend to be more expensive. Some manufacturers such as MuRata and Coilcraft have new bobbin-wound inductors with shielding included, which may be an ideal fit for these applications. Contact the manufacturer for more information.

The inductor size needs to be in the range of  $47\mu\text{H}$  to  $1\text{mH}$ . In general, larger inductor sizes deliver less current, so the load current will determine the inductor size used.

For load currents higher than  $10\text{mA}$ , use an inductor from  $47\mu\text{H}$  to  $100\mu\text{H}$ .

For load currents of about  $5\text{mA}$  (pagers for example), use of an inductor in the range of  $100\mu\text{H}$  to  $330\mu\text{H}$  is desirable.

For even lighter loads, an inductor of up to  $1\text{mH}$  can be used. The use of a larger inductor will increase overall conversion efficiency due to the reduction in switching currents.

For the ILC6371, using an external transistor, the use of a  $47\mu\text{H}$  inductor is recommended based on our experience with the part. Note that these values are recommended for both  $50\text{kHz}$  and  $100\text{kHz}$  operation. If the ILC6370 or ILC6371 is used at  $180\text{kHz}$  switching frequencies, the inductor size can be reduced to approximately half of these stated values.

The capacitor should, in general, be ceramic or tantalum type, as they have much better ESR and temperature stability than other capacitor types. NEVER use electrolytics or chemical caps, as the capacitor value changes dramatically below  $0^\circ\text{C}$  and the overall design may become unstable.

Different capacitor values will directly impact the ripple voltage seen on the output at a given load current due to the direct charge-to-voltage relationship of this element. Different capacitor values will also indirectly affect system reliability, as the lifetime of the capacitor can be degraded by constant high current influx and outflux. Running a capacitor near its maximum rated voltage can deteriorate lifetime as well; this is especially true for tantalum caps which are particularly sensitive to overvoltage conditions.

The diode must be of Schottky type for fast recovery and minimal loss. A diode rated at greater than  $200\text{mA}$  and maximum voltage greater than  $30\text{V}$  is recommended for fast switching time and best reliability over time. Different diodes may introduce different level of high frequency switching noise into the output waveform so trying out several sources may be desirable.

For the ILC6371, much of the component selection is as described above, with the addition of the external NPN transistor and the base drive network. The transistor needs to be of NPN type, and should be rated for currents of  $2\text{A}$  or more. *[This translates to lower effective on resistance and, therefore, higher overall efficiencies.]* The base components should remain at  $1\text{k}\Omega$  and  $3300\text{pF}$ ; any changes need to be verified prior to implementation.

As for actual physical component layout, in general, the more compact the layout is, the better the overall performance will be. It is important to remember that everything in the circuit depends on a common and solid ground reference. Ground bounce can directly affect the output regulation and presents difficult behavior to predict. Keeping all ground traces wide will eliminate ground bounce problems.

It is also critical that the ground pin of  $C_L$  and  $V_{SS}$  pin of the device be the same pin on the board, as this capacitor serves two functions: that of the output load capacitor, and that of the input supply bypass capacitor.

Layouts for DC-DC converter designs are critical for overall performance, but following these simple guidelines can simplify the task by avoiding some of the more common mistakes made in these cases. Once actual performance is completed, be sure to double check the design on an actual manufacturing prototype product to verify that nothing has changed which can affect the performance.

# Typical Performance Characteristics (General conditions for all curves)

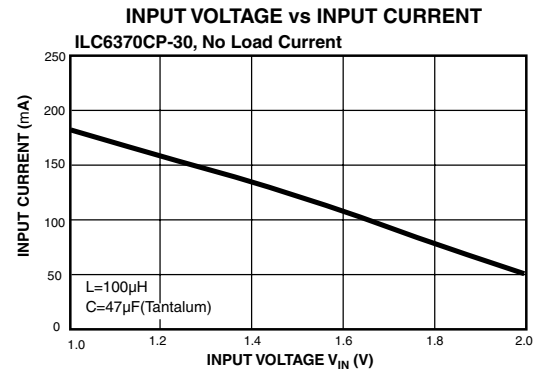
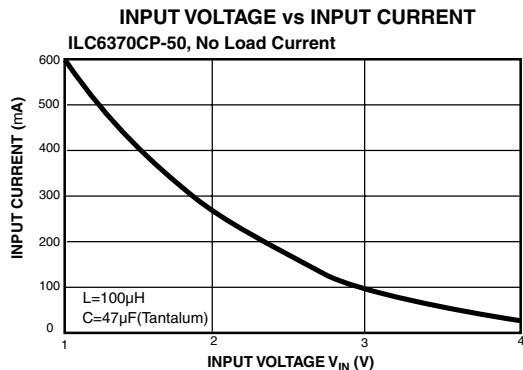
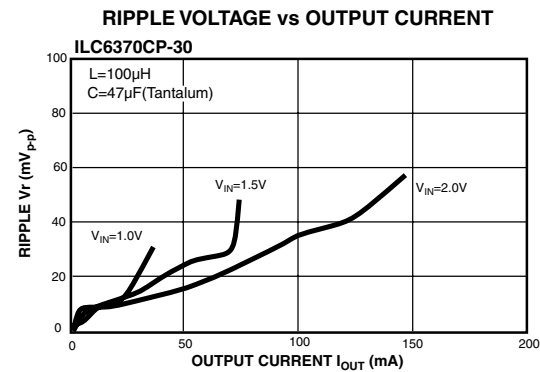
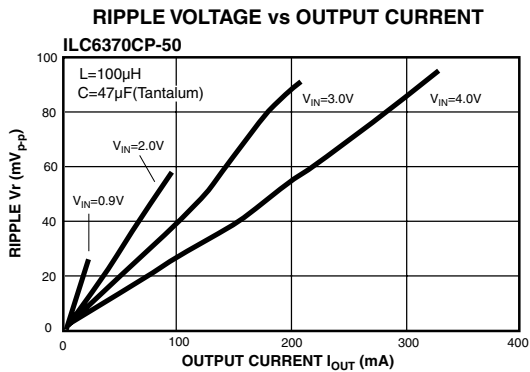
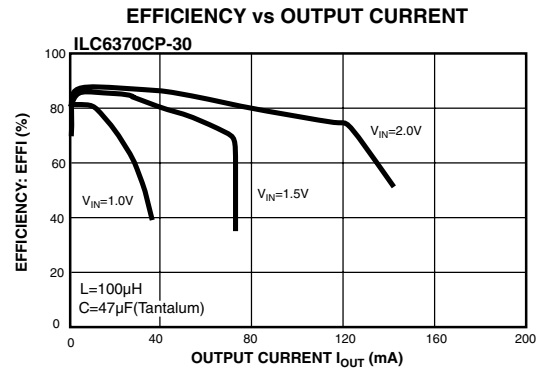
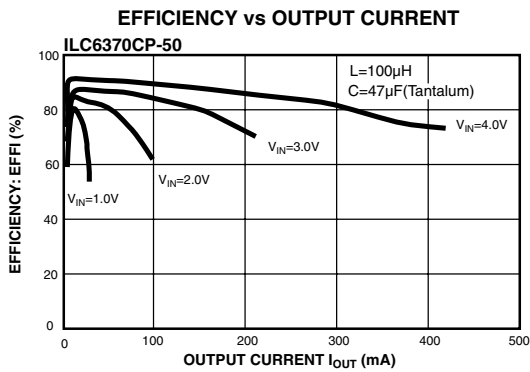
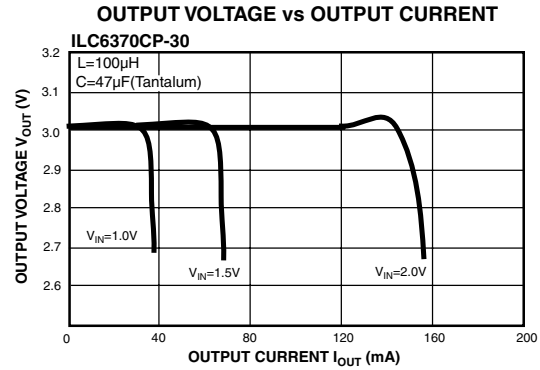
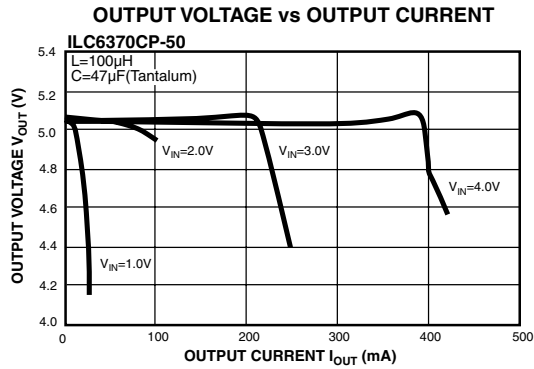

## Typical Performance Characteristics (General conditions for all curves)

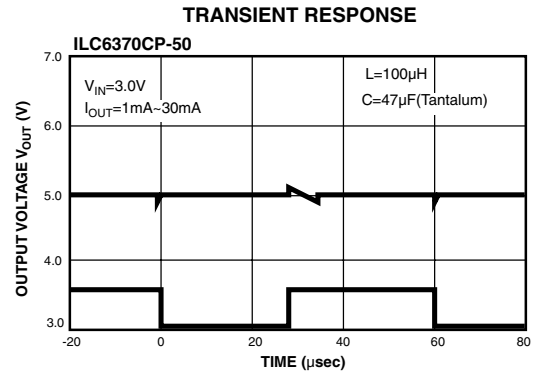
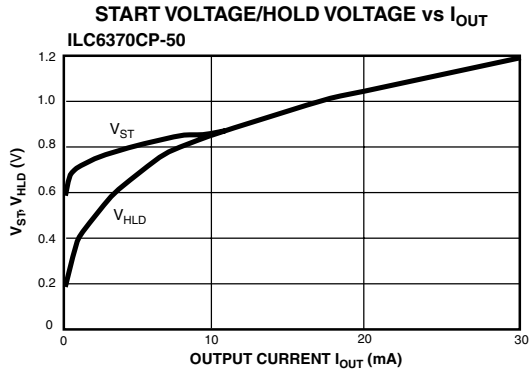



# Package Dimensions

## 5-Lead SOT-89

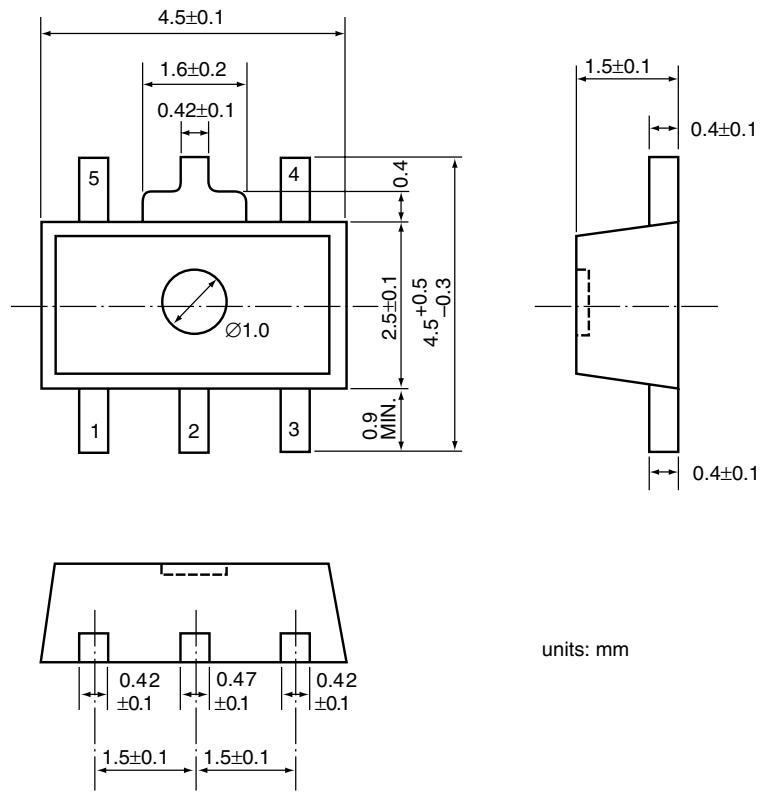

units: mm

## Ordering Information

Part Number	Output voltage @ Switching Frequency
ILC6370CP25X	2.5V $\pm$ 2.5% @ 50kHz
ILC6370CP33X	3.3V $\pm$ 2.5% @ 50kHz
ILC6370CP50X	5.0V $\pm$ 2.5% @ 50kHz
ILC6370BP25X	2.5V $\pm$ 2.5% @ 100kHz
ILC6370BP30X	3.0V $\pm$ 2.5% @ 100kHz
ILC6370BP33X	3.3V $\pm$ 2.5% @ 100kHz
ILC6370BP50X	5.0V $\pm$ 2.5% @ 100kHz
ILC6370BP53X	5.3V $\pm$ 2.5% @ 100kHz
ILC6370AP25X	2.5V $\pm$ 2.5% @ 180kHz
ILC6370AP33X	3.3V $\pm$ 2.5% @ 180kHz
ILC6370AP50X	5.0V $\pm$ 2.5% @ 180kHz
ILC6370AP52X	5.2V $\pm$ 2.5% @ 180kHz
ILC6371CP25X	2.5V $\pm$ 2.5% @ 50kHz
ILC6371CP33X	3.3V $\pm$ 2.5% @ 50kHz
ILC6371CP50X	5.0V $\pm$ 2.5% @ 50kHz
ILC6371BP25X	2.5V $\pm$ 2.5% @ 100kHz
ILC6371BP33X	3.3V $\pm$ 2.5% @ 100kHz
ILC6371BP50X	5.0V $\pm$ 2.5% @ 100kHz
ILC6371AP25X	2.5V $\pm$ 2.5% @ 180kHz
ILC6371AP33X	3.3V $\pm$ 2.5% @ 180kHz
ILC6371AP50X	5.0V $\pm$ 2.5% @ 180kHz
Standard product offering comes in tape and reel, quantity 1000 per reel, orientation right for SOT-89	

### DISCLAIMER

FAIRCHILD SEMICONDUCTOR RESERVES THE RIGHT TO MAKE CHANGES WITHOUT FURTHER NOTICE TO ANY PRODUCTS HEREIN TO IMPROVE RELIABILITY, FUNCTION OR DESIGN. FAIRCHILD DOES NOT ASSUME ANY LIABILITY ARISING OUT OF THE APPLICATION OR USE OF ANY PRODUCT OR CIRCUIT DESCRIBED HEREIN; NEITHER DOES IT CONVEY ANY LICENSE UNDER ITS PATENT RIGHTS, NOR THE RIGHTS OF OTHERS.

### LIFE SUPPORT POLICY

FAIRCHILD'S PRODUCTS ARE NOT AUTHORIZED FOR USE AS CRITICAL COMPONENTS IN LIFE SUPPORT DEVICES OR SYSTEMS WITHOUT THE EXPRESS WRITTEN APPROVAL OF THE PRESIDENT OF FAIRCHILD SEMICONDUCTOR CORPORATION. As used herein:

1. Life support devices or systems are devices or systems which, (a) are intended for surgical implant into the body, or (b) support or sustain life, and (c) whose failure to perform when properly used in accordance with instructions for use provided in the labeling, can be reasonably expected to result in a significant injury of the user.
2. A critical component in any component of a life support device or system whose failure to perform can be reasonably expected to cause the failure of the life support device or system, or to affect its safety or effectiveness.