

## ILC6380/81

SOT-89 Step-up Dual-Mode Switcher with Shutdown



### General Description

100mA boost converter in 5-lead SOT-89 package using both PFM and PWM conversion techniques. In normal operation the ILC6380 runs in PWM mode running at one of three fixed frequencies. At light loads the ILC6380 senses when the duty cycle drops to approximately 10%, and automatically switches into a power-saving PFM switching technique. This maintains high efficiencies both at full load and in system sleep conditions.

Only 3 external components are needed to complete the switcher design, and standard voltage options of 2.5, 3.3, and 5.0V at  $\pm 2.5\%$  accuracy feature on-chip phase compensation and soft-start design.

ILC6381 drives an external transistor for higher current switcher design, with all of the features and benefits of the ILC6380.

### Package Features

- ◆ 85% efficiency at 50mA
- ◆ Start-up voltages as low as 900mV
- ◆  $\pm 2.5\%$  accurate outputs
- ◆ Complete switcher design with only 3 external components
- ◆ 50, 100 and 180kHz switching frequency versions available
- ◆ Shutdown to  $0.5\mu\text{A } I_q$
- ◆ External transistor option allows several hundred milliamp switcher design

### Applications

- ◆ Cellular Phones, Pagers
- ◆ Portable Cameras and Video Recorders
- ◆ Palmtops and PDAs

### Block Diagram

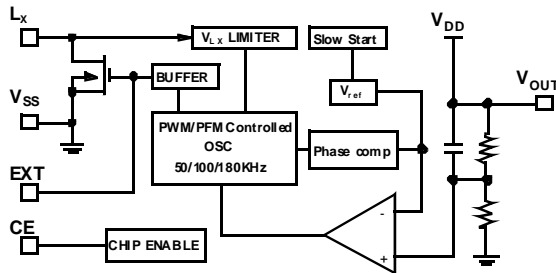

$V_{DD}$  is internally connected to the  $V_{OUT}$  pin.

### Pin Package Configurations

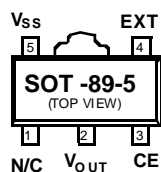
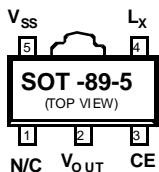

### Ordering Information

ILC6380CP-25	2.5V $\pm 2.5\%$ @50kHz
ILC6380CP-33	3.3V $\pm 2.5\%$ @50kHz
ILC6380CP-50	5.0V $\pm 2.5\%$ @50kHz
ILC6380CP-25	2.5V $\pm 2.5\%$ @100kHz
ILC6380CP-33	3.3V $\pm 2.5\%$ @100kHz
ILC6380CP-50	5.0V $\pm 2.5\%$ @100kHz
ILC6380CP-25	2.5V $\pm 2.5\%$ @180kHz
ILC6380CP-33	3.3V $\pm 2.5\%$ @180kHz
ILC6380CP-50	5.0V $\pm 2.5\%$ @180kHz
ILC6381CP-25	2.5V $\pm 2.5\%$ @50kHz, external xtor
ILC6381CP-33	3.3V $\pm 2.5\%$ @50kHz, external xtor
ILC6381CP-50	5.0V $\pm 2.5\%$ @50kHz, external xtor
ILC6381BP-25	2.5V $\pm 2.5\%$ @100kHz, external xtor
ILC6381BP-33	3.3V $\pm 2.5\%$ @100kHz, external xtor
ILC6381BP-50	5.0V $\pm 2.5\%$ @100kHz, external xtor
ILC6381AP-25	2.5V $\pm 2.5\%$ @180kHz, external xtor
ILC6381AP-33	3.3V $\pm 2.5\%$ @180kHz, external xtor
ILC6381AP-50	5.0V $\pm 2.5\%$ @180kHz, external xtor

\*Standard product offering comes in tape & reel, quantity 1000 per reel, orientation right for SOT-89

## Absolute Maximum Ratings ( $T_A = 25^\circ\text{C}$ )

Parameter	Symbol	Ratings	Units
$V_{OUT}$ Input Voltage	$V_{OUT}$	12	V
Voltage on pin $L_X$	$V_{LX}$	12	V
Current on pin $L_X$	$I_{LX}$	400	mA
Voltage on pin EXT	$V_{EXT}$	$V_{SS}-0.3\sim V_{OUT}+0.3$	V
Current on pin EXT	$I_{EXT}$	$\pm 50$	mA
CE Input Voltage	$V_{CE}$	12	V
Continuous Total Power Dissipation	$P_D$	500	mW
Operating Ambient Temperature	$T_{OPR}$	$-30\sim+80$	$^\circ\text{C}$
Storage Temperature	$T_{STG}$	$-40\sim+125$	$^\circ\text{C}$

Stresses above those listed under ABSOLUTE MAXIMUM RATINGS may cause permanent device failure. Functionality at or above these limits is not implied. Exposure to absolute maximum ratings for extended periods may affect device reliability. Operating ranges define those limits between which the functionality of the device is guaranteed.

## Electrical Characteristics

$V_{OUT} = 5.0\text{V}$ ,  $F_{OSC} = 100\text{kHz}$ ,  $T_A = 25^\circ\text{C}$ . Unless otherwise specified,  $V_{IN} = V_{OUT} \times 0.6$ ,  $I_{OUT} = 50\text{mA}$ . See schematic, figure 3

Parameter	Symbol	Conditions	Min	Typ	Max	Units
Output Voltage	$V_{OUT}$		4.875	5.000	5.125	V
Input Voltage	$V_{IN}$				10	V
Oscillation Startup Voltage	$V_{ST}$	$L_X = 10\text{k}\Omega$ pull-up to 5V, $V_{OUT} = V_{ST}$			0.8	V
Operation Startup Voltage	$V_{ST1}$	$I_{OUT} = 1\text{mA}$			0.9	V
No-Load Input Current	$I_{IN}$	$I_{OUT} = 0\text{mA}$ (See Note 1)		23.0	46.0	$\mu\text{A}$
Supply Current 1 (See Note 2)	$I_{DD1}$	$L_X = 10\text{k}\Omega$ pull-up to 5V, $V_{OUT} = 4.5\text{V}$		78.6	131.1	$\mu\text{A}$
Supply Current 2	$I_{DD2}$	$L_X = 10\text{k}\Omega$ pull-up to 5V, $V_{OUT} = 5.5\text{V}$		6.9	13.8	$\mu\text{A}$
$L_X$ Switch-On Resistance	$R_{SWON}$	$L_X = 10\text{k}\Omega$ pull-up to 5V, $V_{OUT} = 4.5\text{V}$		1.3	2.3	$\Omega$
$L_X$ Leakage Current	$I_{LXL}$	No external components, $V_{OUT} = V_{LX} = 10\text{V}$			1.0	$\mu\text{A}$
Oscillator Freq.	$F_{OSC}$	$L_X = 10\text{k}\Omega$ pull-up to 5V, $V_{OUT} = 4.5\text{V}$ , Measuring of $L_X$ waveform	85	100	115	kHz
Maximum Duty Ratio	MAXDTY	$L_X = 10\text{k}\Omega$ pull-up to 5V, $V_{OUT} = 4.5\text{V}$ , Measuring of $L_X$ on-time	80	87	92	%
PFM Duty Ratio	PFMDTY	$V_{IN} = 4.75\text{V}$ , Measuring of $L_X$ on-time	5	10	20	%
Stand-by Current	$I_{STB}$	$L_X = 10\text{k}\Omega$ pull-up to 5V, $V_{OUT} = 4.5\text{V}$			0.5	$\mu\text{A}$
CE "High" Voltage	$V_{CEH}$	$L_X = 10\text{k}\Omega$ pull-up to 5V, $V_{OUT} = 4.5\text{V}$ , Existence of $L_X$ Oscillation	0.75			V
CE "Low" Voltage	$V_{CEL}$	$L_X = 10\text{k}\Omega$ pull-up to 5V, $V_{OUT} = 4.5\text{V}$ , Stopped $L_X$ Oscillation			0.20	V
CE "High" Current	$I_{CEH}$	$L_X = 10\text{k}\Omega$ pull-up to 5V, $V_{OUT} = V_{CE} = 4.5\text{V}$			0.25	$\mu\text{A}$
CE "Low" Current	$I_{CEL}$	$L_X = 10\text{k}\Omega$ pull-up to 5V, $V_{OUT} = 4.5\text{V}$ , $V_{CE} = 0\text{V}$			-0.25	$\mu\text{A}$
$L_X$ Limit Voltage	$V_{LXLMT}$	$L_X = 10\text{k}\Omega$ pull-up to 5V, $V_{OUT} = 4.5\text{V}$ , $F_{OSC} > F_{OSC} \times 2$ (See Note 2)	0.7		1.1	V
Efficiency	EFFI			85		%
Slow Start Time	$T_{SS}$			10		msec

### Notes:

- The Schottky diode (S.D.), in figure 3 must be type MA735, with Reverse current (IR) < 1.0 $\mu\text{A}$  at reverse voltage (VR)=10.0V
- "Supply Current 1" is the supply current while the oscillator is continuously oscillating. In actual operation the oscillator periodically operates which results in less average power consumption.  
The current that is actually provided by external  $V_{IN}$  source is represented by "No-Load Input Current(IIN)"
- Switching frequency is determined by delay time of internal comparator to turn  $L_X$  "off", and minimum "on" time as determined by MAXDTY spec.

## Electrical Characteristics ILC6380BP-50

$V_{OUT} = 5.0V$ ,  $F_{OSC} = 100kHz$ ,  $T_A = 25^\circ C$ . Unless otherwise specified,  $V_{IN} = V_{OUT} \times 0.6$ ,  $I_{OUT} = 50mA$ . See the schematic, figure 4.

Parameter	Symbol	Conditions	Min	Typ	Max	Units
Output Voltage	$V_{OUT}$	Test Circuit of Figure 2	4.875	5.000	5.125	V
Input Voltage	$V_{IN}$				10	V
Oscillation Startup Voltage	$V_{ST2}$	$V_{OUT} = V_{ST2}$			0.8	V
Operation Startup Voltage	$V_{ST1}$	$I_{OUT} = 1mA$			0.9	V
Supply Current 1 (See Note 2)	$I_{DD1}$	EXT = 10k $\Omega$ pull-up to 5V, $V_{OUT} = 4.5V$		78.6	131.1	$\mu A$
Supply Current 2	$I_{DD2}$	EXT = 10k $\Omega$ pull-up to 5V, $V_{OUT} = 5.5V$		6.9	13.8	$\mu A$
EXT "High" On-Resistance	$R_{EXTH}$	EXT = 10k $\Omega$ pull-up to 5V, $V_{OUT} = 4.5V$ , $V_{EXT} = V_{OUT} - 0.4V$		30	50	$\Omega$
EXT "Low" On-Resistance	$R_{EXTL}$	EXT = 10 $\Omega$ pull-up to 5V, $V_{OUT} = 4.5V$ , $V_{EXT} = V_{OUT} - 0.4V$		30	50	$\Omega$
Oscillator Frequency	$F_{OSC}$	EXT = 10k $\Omega$ pull-up to 5V, $V_{OUT} = 4.5V$ , Measuring of EXT waveform	85	100	115	kHz
Maximum Duty Ratio	MAXDTY	EXT = 10k $\Omega$ pull-up to 5V, $V_{OUT} = 4.5V$ , Measuring of EXT high state	80	87	92	%
CE "High" Voltage	$V_{CEH}$	EXT = 10k $\Omega$ pull-up to 5V, $V_{OUT} = 4.5V$ , Existence of Oscillation	0.75			V
CE "Low" Voltage	$V_{CEL}$	EXT = 10k $\Omega$ pull-up to 5V, $V_{OUT} = 4.5V$ , Stopped EXT Oscillation			0.20	V
CE "High" Current	$I_{CEH}$	EXT: 10k $\Omega$ pull-up to 5V, $V_{OUT} = 4.5V$ , $V_{CE} = V_{OUT} \times 0.95V$			0.25	$\mu A$
CE "Low" Current	$I_{CEL}$	EXT = 10k $\Omega$ pull-up to 5V, $V_{OUT} = 4.5V$ , $V_{CE} = 0V$			-0.25	$\mu A$
Efficiency	EFFI			85		%
Slow Start Time	$T_{SS}$			10		msec

Notes:

- The Schottky diode (S.D.), in figure 3 must be type MA735, with Reverse current ( $I_R$ ) < 1.0 $\mu A$  at reverse voltage ( $V_R$ )=10.0V
- "Supply Current 1" is the supply current while the oscillator is continuously oscillating. In actual operation the oscillator periodically operates which results in less average power consumption. The current that is actually provided by external  $V_{IN}$  source is represented by "No-Load Input Current ( $I_{IN}$ )"

## Typical Applications

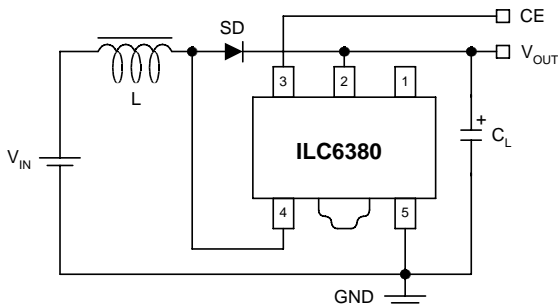

**Figure 3**

L: 100 $\mu H$  (SUMIDA, CD-54)  
SD: Diode (Schottky diode; MATSUSHITA MA735)  
CL: 16V 47 $\mu F$  (Tantalum Capacitor; NICHICON, F93)

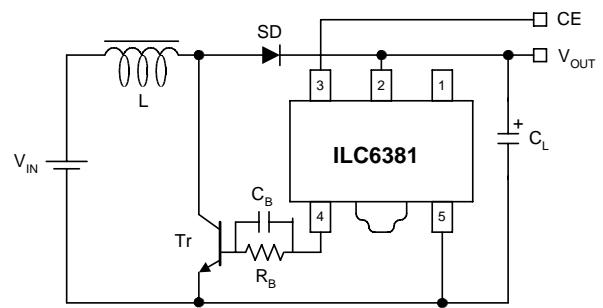
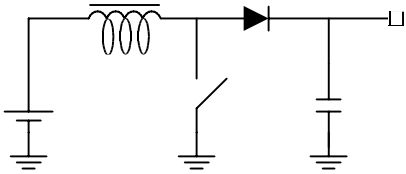

**Figure 4**

L: 47 $\mu H$  (SUMIDA, CD-54)  
SD: Diode (Schottky diode; MATSUSHITA MA735)  
CL: 16V 47 $\mu F$  (Tantalum Capacitor; NICHICON, F93)  
RB: 1kW  
CB: 3300pF  
Tr: 2SC3279, 2SDI628G

## Functions and Operation

The ILC6380 performs boost DC-DC conversion by controlling the switch element shown in the circuit below



When the switch is closed, current is built up through the inductor. When the switch opens, this current has to go somewhere and is forced through the diode to the output. As this on and off switching continues, the output capacitor voltage builds up due to the charge it is storing from the inductor current. In this way, the output voltage gets boosted relative to the input. The ILC6380 monitors the voltage on the output capacitor to determine how much and how often to drive the switch.

In general, the switching characteristic is determined by the output voltage desired and the current required by the load. Specifically the energy transfer is determined by the power stored in the coil during each switching cycle.

$$PL = f(t_{ON}, V_{IN})$$

The ILC6380 and ILC6381 use a PWM or Pulse Width Modulation technique. The parts come in one of three fixed internal frequencies: 50, 100, or 180kHz. The switches are constantly driven at these frequencies. The control circuitry varies the power being delivered to the load by varying the on-time, or duty cycle, of the switch. Since more on-time translates to higher current build-up in the inductor, the maximum duty cycle of the switch determines the maximum load current that the device can support. The ILC6380 and ILC6381 both support up to 87% duty cycles, for maximum usable range of load currents.

There are two key advantages of the PWM type controllers. First, because the controller automatically varies the duty cycle of the switch's on-time in response to changing load conditions, the PWM controller will always have an optimized waveform for a steady-state load. This translates to very good efficiency at high currents and minimal ripple on the output. [Ripple is due to the output cap constantly accepting and storing the charge received from the inductor, and delivering charge as required by the load. The "pumping" action of the switch produces a sawtooth-shaped voltage as seen by the output.]

The other key advantage of the PWM type controllers is that the radiated noise due to the switching transients will always occur at the (fixed) switching frequency. Many applications do not care much about switching noise, but certain types of applications, especially communication equipment, need to minimize the high frequency interference within their system as much as is possible. Using a boost converter requires a certain amount of higher frequency noise to be generated; using a PWM converter makes that noise highly predictable; thus easier to filter out.

### Dual Mode Operation

But there are downsides of PWM approaches, especially at very low currents. Because the PWM technique relies on constant switching and varying duty cycle to match the load conditions, there is some point where the load current gets too small to be handled efficiently. An actual switch consumes some finite amount of current to switch on and off; at very low currents this can be of the same magnitude as the load current itself, driving switching efficiencies down to 50% and below. The ILC6380 and ILC6381 overcome this limitation by automatically switching over to a PFM, or Pulse Frequency Modulation, technique at low currents. This technique conserves power loss by only switching the output if the current drain requires it. As shown in the diagram below, the waveform actually skips pulses depending on the power needed by the output. [This technique is also called "pulse skipping" because of this characteristic.]

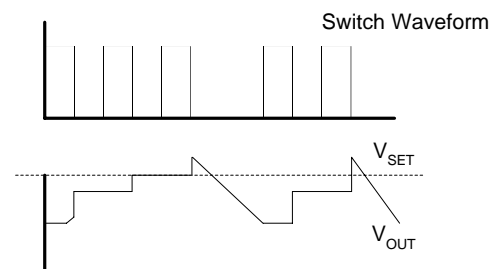

In the ILC6380 and ILC6381, this switchover is internally set to be at the point where the PWM waveform hits approximately 10% duty cycle. So the PFM mode is running at 10% duty cycle at the rated frequency; for 100kHz part this means a constant on-time of 1msec. This not only is ideal for efficiency at these low currents, but a 10% duty cycle will have much better output ripple characteristics than a similarly configured PFM part, such as the ILC6390 and ILC6391.

The Dual-Mode architecture was designed specifically for those applications, like communications, which need the spectral predictability of a PWM-type DC-DC converter, yet which also needs the highest efficiencies possible, especially in Shutdown or Standby mode. [For other conversion techniques, please see the ILC6370/71 and ILC6390/91 datasheets.]

### Other Considerations

The other limitation of PWM techniques is that, while the fundamental switching frequency is easier to filter out since it's constant, the higher order harmonics of PWM will be present and may have to be filtered out, as well. Any filtering requirements, though, will vary by application and by actual system design and layout, so generalizations in this area are difficult, at best.

However, PWM control for boost DC-DC conversion is widely used, especially in audio-noise sensitive applications or applications requiring strict filtering of the high frequency components. Impala's products give very good efficiencies of 85% at 50mA output (5V product), 87% maximum duty cycles for high load conditions, while maintaining very low shutdown current levels of

0.5mA. The only difference between the ILC6380 and ILC6381 parts is that the 6381 is configured to drive an external transistor as the switch element. Since larger transistors can be selected for this element, higher effective loads can be regulated.

## Start-up Mode

The ILC6380 has an internal soft-start mode which suppresses ringing or overshoot on the output during start-up. The following diagram illustrates this start-up condition's typical performance:

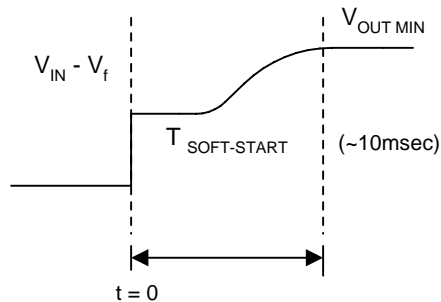

## External Components and Layout Consideration

The ILC6380 is designed to provide a complete DC-DC converter solution with a minimum of external components. Ideally, only three externals are required: the inductor, a pass diode, and an output capacitor.

The inductor needs to be of low DC Resistance type, typically  $1\Omega$  value. Toroidal wound inductors have better field containment (less high frequency noise radiated out) but tend to be more expensive. Some manufacturers like Coilcraft have new bobbin-wound inductors with shielding included, which may be an ideal fit for these applications. Contact the manufacturer for more information.

The inductor size needs to be in the range of 47mH to 1mH. In general, larger inductor sizes deliver less current, so the load current will determine the inductor size used.

For load currents higher than 10mA, use an inductor from 47mH to 100mH. [The 100mH inductor shown in the datasheet is the most typical used for this application.]

For load currents of around 5mA, such as pagers, use an inductor in the range of 100mH to 330mH. 220mH is the most typical value used here.

For lighter loads, an inductor of up to 1mH can be used. The use of a larger inductor will increase overall conversion efficiency, due to the reduction in switching currents through the device.

For the ILC6381, using an external transistor, the use of a 47mH inductor is recommended based on our experience with the part. Note that these values are recommended for both 50kHz and 100kHz operation. If using the ILC6380 or ILC6381 at 180kHz, the inductor size can be reduced to approximately half of these stated values.

The capacitor should, in general, always be tantalum type, as tantalum has much better ESR and temperature stability than other capacitor types. NEVER use electrolytics or chemical caps, as the C-value changes below  $0^{\circ}\text{C}$  so much as to make the overall design unstable.

Different C-values will directly impact the ripple seen on the output at a given load current, due to the direct charge-to-voltage relationship of this element. Different C-values will also indirectly affect system reliability, as the lifetime of the capacitor can be degraded by constant high current influx and outflux. Running a capacitor near its maximum rated voltage can deteriorate lifetime as well; this is especially true for tantalum caps which are particularly sensitive to overvoltage conditions.

In general, then, this capacitor should always be 47mF, Tantalum, 16V rating.

The diode must be of shottkey type for fast recovery and minimal loss. A diode rated at greater than 200mA and maximum voltage greater than 30V is recommended for the fastest switching time and best reliability over time. Different diodes may introduce different levels of high frequency switching noise into the output waveform, so trying out several sources may make the most sense for your system.

For the ILC6381, much of the component selection is as described above, with the addition of the external NPN transistor and the base drive network. The transistor needs to be of NPN type, and should be rated for currents of 2A or more. [This translates to lower effective on resistance and, therefore, higher overall efficiencies.] The base components should remain at  $1\text{k}\Omega$  and 330pF; any changes need to be verified prior to implementation.

As for actual physical component layout, in general, the more compact the layout is, the better the overall performance will be. It is important to remember that everything in the circuit depends on a common and solid ground reference. Ground bounce can directly affect the output regulation and presents difficult behavior to predict. Keeping all ground traces wide will eliminate ground bounce problems.

It is also critical that the ground pin of  $C_L$  and the  $V_{SS}$  pin of the device be the same point on the board, as this capacitor serves two functions: that of the output load capacitor, and that of the input supply bypass capacitor.

Layouts for DC-DC converter designs are critical for overall performance, but following these simple guidelines can simplify the task by avoiding some of the more common mistakes made in these cases. Once actual performance is completed, though, be sure to double-check the design on actual manufacturing prototype product to verify that nothing has changed which can affect the performance.

Typical Performance Characteristics General conditions for all curves

