

**INTERFACE TRANSCEIVER OF THE SERIAL DATA
OF THE STANDARD RS -485
(compatible to MAX3485 (MAXIM USA))**

ILX3485N is interface transceiver of serial data. ILX3485N is purposed for application in low power telecom systems, that correspond to RS – 485, RS – 422 standards, level translators, transceiver units & E-field sensitive automation systems of industrial devices.

Functions and structure:

- Microcircuit contains 1 transmitter and 1 receivers of the serial data of the standard RS-485.
- The microcircuit supply voltage range is from 3.0 to 3.6 V.
- The microcircuits is available in 8-pin DIP-package (MS-001BA).

Logic Symbol

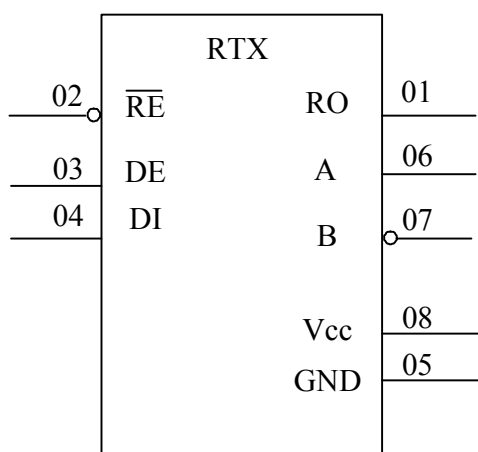

Functional diagram

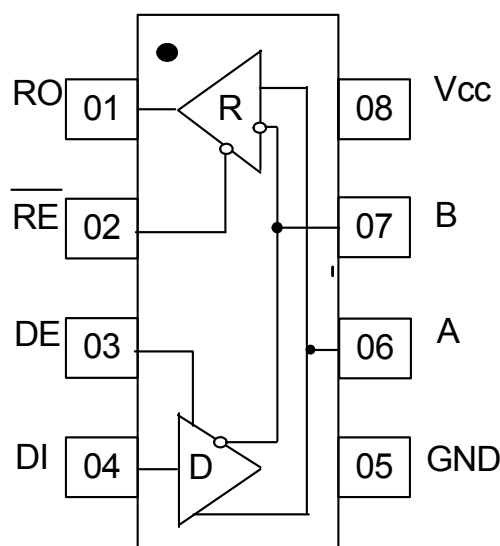

Pin description table

Pin number	Pin description	Symbol
01	Receiver output	RO
02	Receiver output enable pin (Low level)	RE
03	Transmitter output enable pin	DE
04	Transmitter input	DI
05	Common pin	GND
06	Receiver/transmitter uncomplemented I/O pin	A
07	Receiver/transmitter complemented I/O pin	B
08	Supply voltage pin	V _{CC}

Pinning diagram

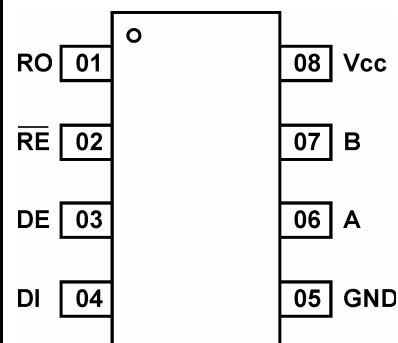

Maximum Ratings & Recommended Operating Conditions

Parameter, unit	Symbol	Recommended operating conditions		Maximum rate	
		min	max	min	max
Supply voltage, V	U_{CC}	3,0	3,6	-	7,0
Input voltage (digital inputs), V	U_I	-	-	-0,3	7,0
Low level input voltage (digital inputs), V	U_{IL}	0	0,8	-	-
High level input voltage (digital inputs), V	U_{IH}	2,0	U_{CC}	-	-
Transmitter output voltage, V	U_{OD}	-7,0	12,0	-7,5	12,5
Receiver input voltage, V	U_{IR}	-7,0	12,0	-7,5	12,5
Voltage applied to receiver output, V	U_{RO}	0	U_{CC}	-0,3	$U_{CC}+0,3$
Ambient temperature, °C	T_A	-40	85	-60	150

Electric parameters

Parameter, unit	Symbol	Norm		Mode	$T_A, ^\circ C$	
		Min	Max			
Low level input leakage current, uA	I_{ILL}	-	-1,0	$U_{CC} = 3,6 V; U_{DE}=U_{DI}=U_{RE}=0 V$	25±10	
			-2,0		-40; 85	
High level input leakage current, uA	I_{ILH}	-	1,0	$U_{CC} = 3,6 V; U_{DE}=U_{DI}=U_{RE}=U_{CC}$	25±10	
			2,0		-40; 85	
Idle mode supply current, uA	I_{CC}	-	1,7	$U_{CC} = 3,6 V, U_{RE} = 0 V$ or U_{CC}	25±10	
			2,2		$U_{DE} = U_{CC}$	-40; 85
			1,4	$U_{CC} = 3,6 V, U_{RE} = 0 V$	25±10	
			1,9		$U_{DE} = 0 V$	-40; 85
Low power consumption mode supply current, uA	I_{SHDN}	-	0,7	$U_{CC} = 3,6 V, U_{DE} = 0 V$	25±10	
			1		$U_{RE} = U_{CC}$ $U_{DI} = 0 V$ or U_{CC}	-40; 85
Time of transition to Low power consumption mode	t_{SHDN}	80	300	$U_{CC} = 3,3 V,$	25±10	
Receiver						
Low level output voltage, V	U_{OL}	-	0,26	$U_{ID} = -180 mV;$ $U_{ID} = -200 mV;$	$U_{CC} = 3,0V;$ $I_{OL} = 2,5 mA$	25±10
			0,4			-40; 85
High level output voltage, V	U_{OH}	2,7	-	$U_{ID} = 180 mV;$ $U_{ID} = 200 mV;$	$U_{CC} = 3,0V;$ $I_{OH} = -1,5 mA$	25±10
			2,6			-40; 85
Input current, mA	I_{IN2}	-	0,85	$U_{IN}=12V$	$U_{CC} = 3,6V;$ $DE=0 V$	25±10
			-0,7	$U_{IN} = -7V$		-40; 85
			1,0	$U_{IN}=12V$		
			-0,8	$U_{IN} = -7V$		
Low level output current for state "Off", uA	I_{OZLR}		-0,25	$U_{CC} = 3,6V; U_O = 0,4 V$	25±10	
			-1,0		-40; 85	
High level output current for state "Off", uA	I_{OZHR}		0,25	$U_{CC} = 3,6V; U_O = 2,4 V$	25±10	
			1,0		-40; 85	
High level short circuit output current, mA	I_{OSHR}	9,0	50	$U_{CC} = 3,6V; U_{IH} = 3,0 V,$ $U_{IL} = 0 V, U_O = 3,6 V$	25±10	
			60		-40; 85	
Low level short circuit output current, mA	I_{OSLR}	-9,0	-50	$U_{CC} = 3,6V; U_{IH} = 3,0 V,$ $U_{IL} = 0 V, U_O = 3,6 V$	25±10	
			-60		-40; 85	
OFF-ON switching propagation delay, ns	$t_{RPHL},$ t_{RPLH}	25	90	$U_{CC} = 3,6V; U_{IH} = 3,0 V,$ $U_{IL} = 0 V, U_O = 0 V$	25±10	



Electric parameters

Parameter, unit	Symbol	Norm		Mode	T _A , °C
		Min	Max		
Receiver					
Propagation delay time of transition from state "Off" to high (low) level	t _{PRZH} (t _{PRLZ})	-	50	U _{CC} = 3,3V, C _L = 15 pF, R _L = 1 kOhm	25±10
Output disable time for transition from high (low) level state to OFF-state	t _{PRHZ} (t _{PRLZ})	-	45		
Propagation delays difference, ns	t _{SKD}	-	10	U _{CC} = 3,3V, C _L = 15 pF,	25±10
Receiver output transition time from shutdown to low level, ns	t _{PRSL}	-	1400	U _{CC} = 3,3V, C _L = 15 pF, R _L = 1 kOhm	25±10
Receiver output transition time from shutdown to high level, ns	t _{PRSH}	-	1400		25±10
Transmitter					
Differential output voltage, V	U _{OD}	1,56	-	U _{CC} =3,3V ±10%; R _L = 54 Ohm (RS-485)	25±10
		1,5	-		-40; 85
		2,08	-	U _{CC} =3,3V ±10%; R _L = 100 Ohm (RS-422)	25±10
		2,0	-		-40; 85
		1,56	-	U _{CC} =3,3V; R _L = 60 Ohm (RS-485)	25±10
		1,5	-		-40; 85
Change in value of differential output voltage for complementary output states	δU _{OD}	0,18	0,2	U _{CC} =3,3V ±10%; R _L = 54 or 100 Ohm	25±10
		0,2			-40; 85
Output bias voltage refer to common pin, V	U _{OC}	-	2,96	U _{CC} =3,3V ±10%; R _L = 54 or 100 Ohm	25±10
		-	3,0		-40; 85
Change in value of bias output voltage for complementary output states	δU _{OC}	0,18	0,2	U _{CC} =3,3V ±10%; R _L = 54 or 100 Ohm	25±10
		0,2			-40; 85
Low level receiver short circuit output current, mA	I _{OSLD}	40	230	U _{CC} =3,6V, U _o = 12 V, U _{IL} = 0 V, U _{IH} = 3,6 V	25±10
		35	250		-40; 85
High level receiver short circuit output current, mA	I _{OSHD}	-40	-230	U _{CC} =3,6V, U _o = -7 V, U _{IL} = 0 V, U _{IH} = 3,6 V	25±10
		-35	-250		-40; 85
Switching propagation delay low to high level (or high to low level), ns	t _{PHL} (t _{PLH})	7	35	U _{CC} =3,3V, R _L = 27 Ohm, C _L =15 pF, U _{IL} = 0 V, U _{IH} = 3,0 V	25±10
Propagation delays difference, ns	t _{SKEW}	-	8	U _{CC} =3,3V, R _L = 27 Ohm, C _L =15 pF, U _{IL} = 0 V, U _{IH} = 3,0 V	25±10
Output transition time OFF state to high level, ns	t _{PZH}	-	90	U _{CC} =3,3V, R _L = 110 Ohm, C _L =50 pF	25±10
Output transition time OFF state to low level, ns	t _{PZL}	-	90	U _{CC} =3,3V, R _L = 110 Ohm, C _L =50 pF	25±10
Output disable time for transition high (low) level to OFF state, ns	t _{PHZ} (t _{PLZ})	-	80	U _{CC} =3,3V, R _L = 110 Ohm, C _L =50 pF	25±10



Electric parameters

Parameter, unit	Symbol	Norm		Mode	T _A , °C
		Min	Max		
Transmitter					
Differential output transition time, ns	t _{TD}	3,0	25	U _{CC} =3,3V, R _L = 60 Ohm, C _L =15 pF	25±10
Maximum data rate, Mbit/s	ST	12	-	U _{CC} =3,3V, R _L = 27 Ohm, C _L =15 pF, U _{IL} = 0 V, U _{IH} = 3.0 V, Q ≥ 2	25±10
Differential output delay time, ns	t _{DD}	1,0	35	U _{CC} =3,3V, R _L = 60 Ohm, C _L =15 pF	25±10
Output enable time from shutdown to low level, ns	t _{PSL}	-	900	U _{CC} =3,3V, R _L = 110 Ohm, C _L =50 pF	25±10
Output enable time from shutdown to high level, ns	t _{PSH}	-	900	U _{CC} =3,3V, R _L = 110 Ohm, C _L =50 pF	25±10

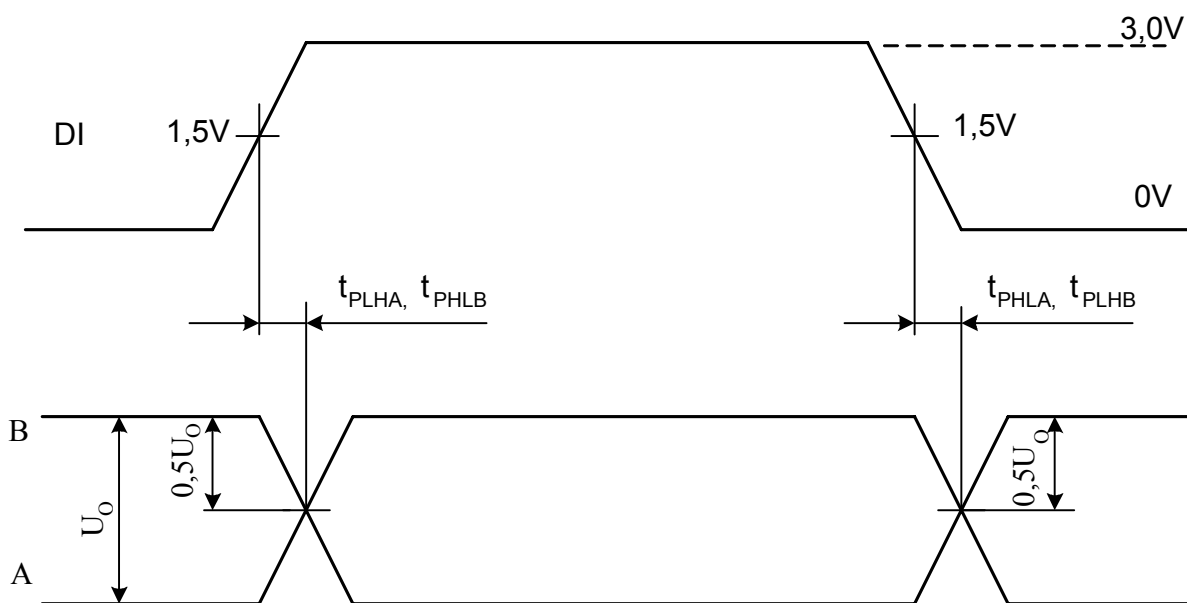

Dynamic parameters t_{PHL}, t_{PLH}, t_{SKEW} timing diagram (transmitter)

Propagation delays difference t_{SKEW}, ns is calculated by formula

$$t_{SKEW} = |(t_{PHLA} + t_{PLHB})/2 - (t_{PLHA} + t_{PHLB})/2|, \quad (1)$$

t_{PHLA}, t_{PLHB}, t_{PLHA}, t_{PHLB} – propagation delays of signal from transmitter input to A, B outputs for ON – OFF switching, ns

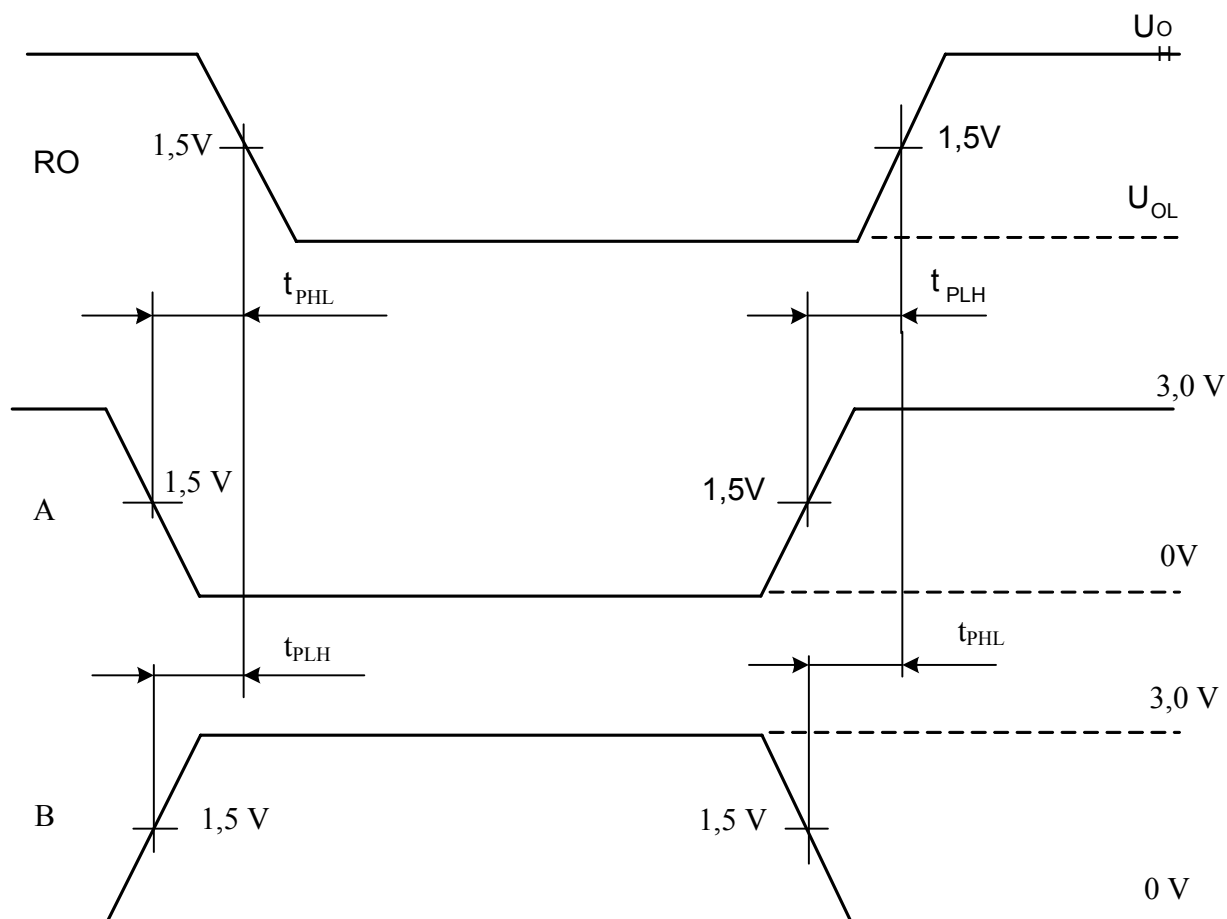

Dynamic parameters t_{RPHL} , t_{RPLH} , t_{SKD} timing diagram (receiver)

Propagation delays difference for ON –OFF switching t_{SKD} , ns is calculated by formula

$$t_{SKD} = | t_{PLH} - t_{PHL} | , \quad (2)$$

t_{PLH} , t_{PHL} , – propagation delays of signal from receiver inputs A or B to RO output for ON – OFF switching, ns

On signal changing on A input, constant voltage 1,5V applied to input B .
 On signal changing on B input, constant voltage 1,5V applied to input A .



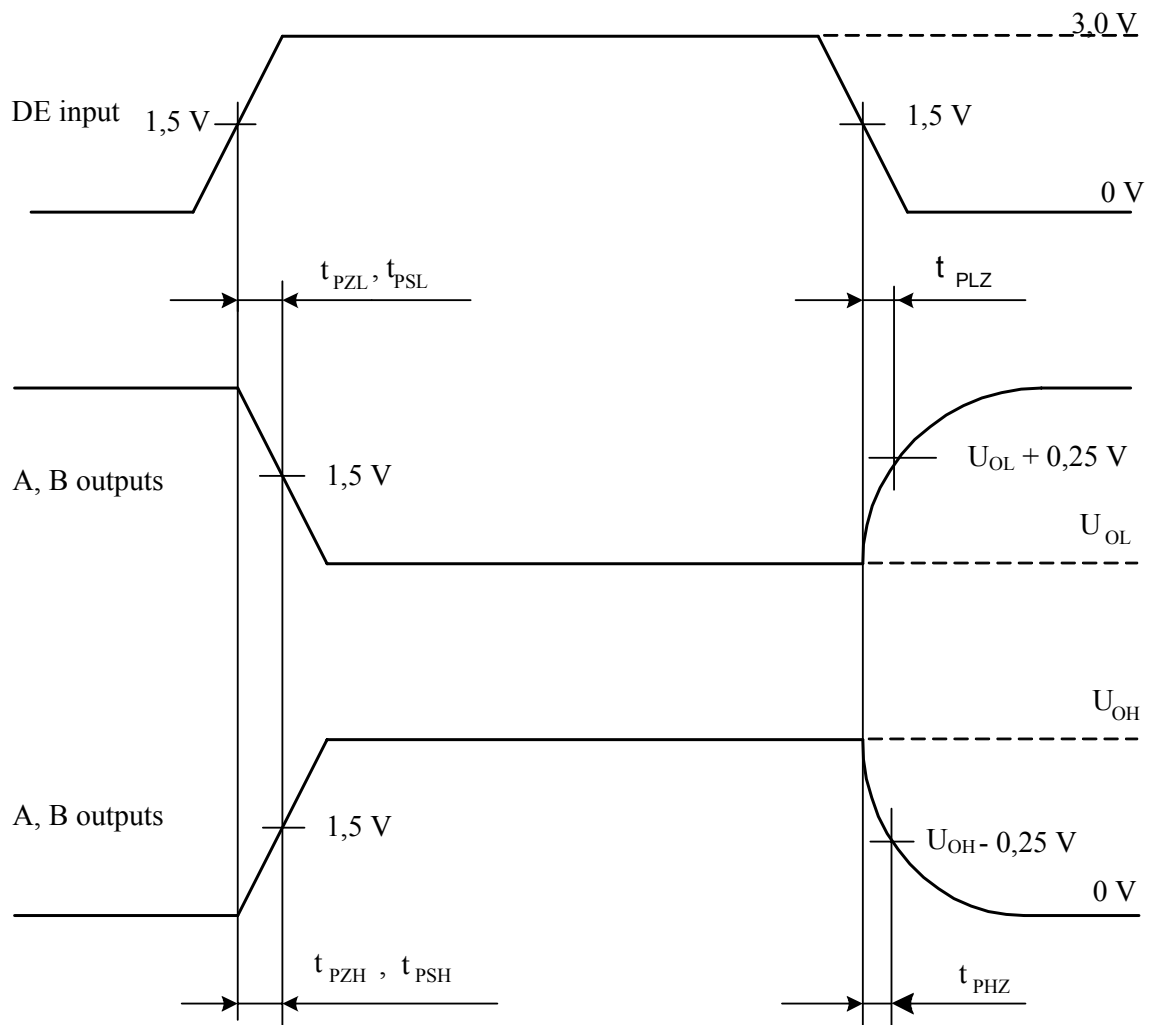

Dynamic parameters t_{PZH} , t_{PZL} , t_{PHZ} , t_{PLZ} , t_{PSH} , t_{PSL} timing diagram (transmitter)

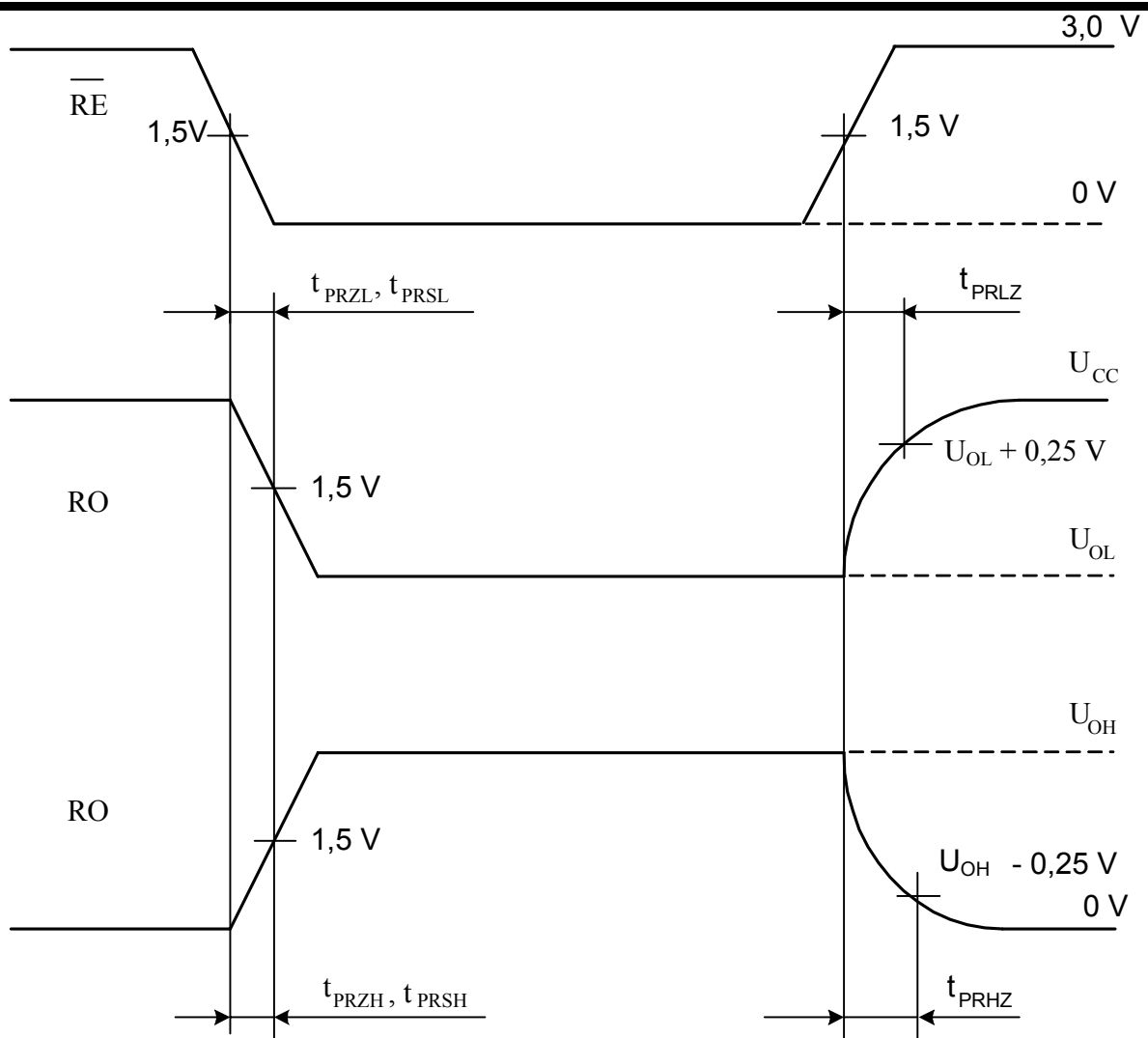

Dynamic parameters t_{PRZH} , t_{PRZL} , t_{PRHZ} , t_{PRLZ} , t_{PRSH} , t_{PRSL} timing diagram (receiver)

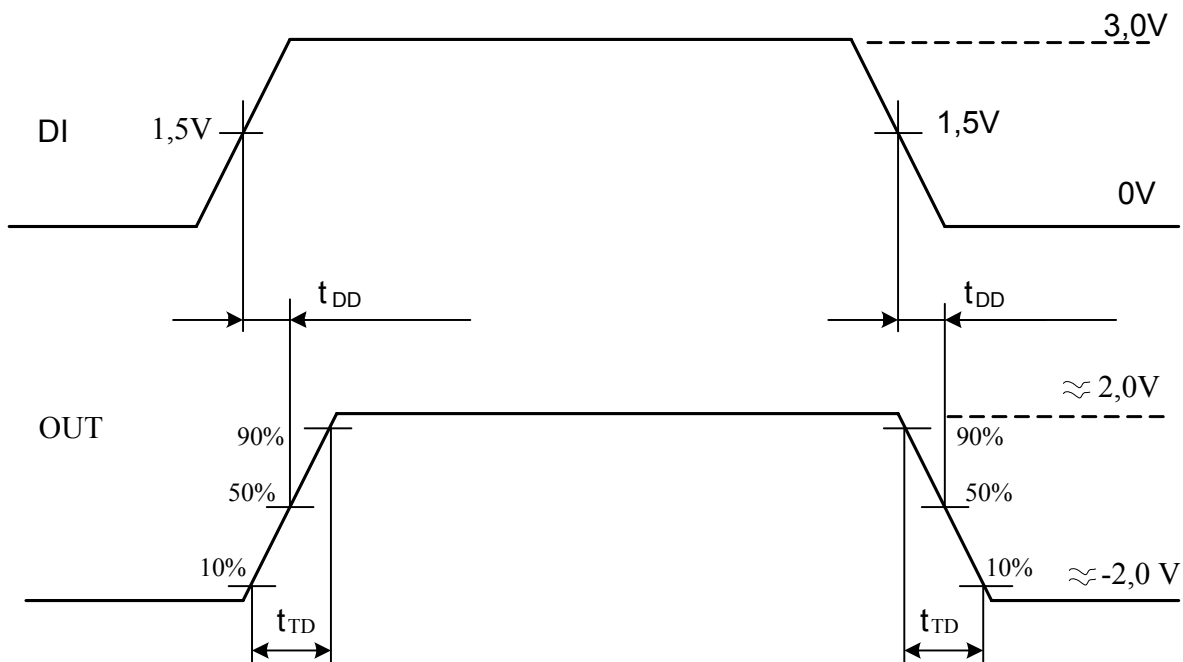

Dynamic parameters t_{DD} , t_{TD} timing diagram (transmitter)

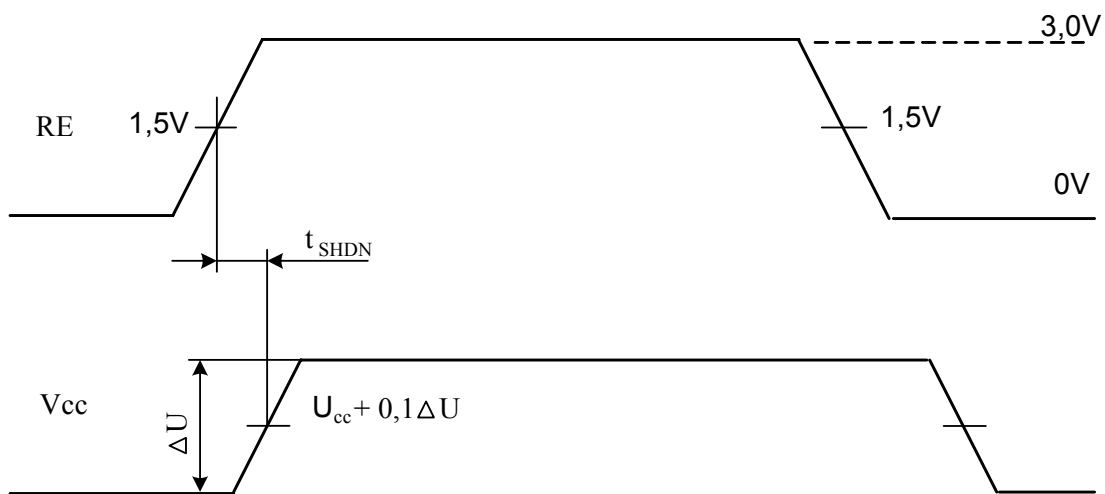

Timing diagram of transition to shutdown mode t_{SHDN}

Package Dimensions
DIP-package MS-001BA

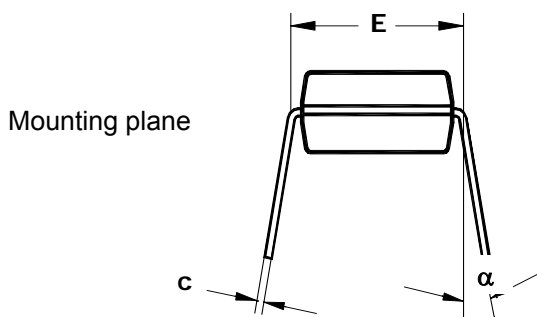
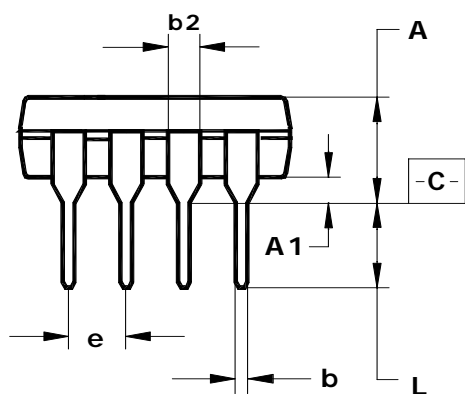
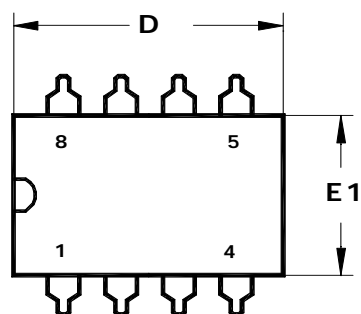

⊕	0,25	(0,010)	Ⓜ	C
------------	------	---------	------------	---

Note - Dimensions D, E1 do not include the fin value, which should not exceed 0.25 mm (0.010 inch) per side.

	D	E1	A	b	b2	e	α	L	E	c	A1
mm											
min	9,02	6,07	—	0,36	1,14		0°	2,93	7,62	0,20	0,38
max	10,16	7,11	5,33	0,56	1,78	2,54	15°	3,81	8,26	0,36	—
inches											
min	0,355	0,240	—	0,014	0,045		0°	0,115	0,300	0,008	0,015
max	0,400	0,280	0,210	0,022	0,070	0,1	15°	0,150	0,325	0,014	—

