



---

INTELLIGENT MOTION SYSTEMS, INC.

*Excellence in Motion™*

# IM2000

**HIGH PERFORMANCE MICROSTEPPING STEP MOTOR CONTROLLER**

**IM2000F - 80 PIN QFP**

**IM2000P - 68 PIN PLCC**

**IM2000S - ULTRA SMALL 64 PIN QFP**

OPERATING INSTRUCTIONS

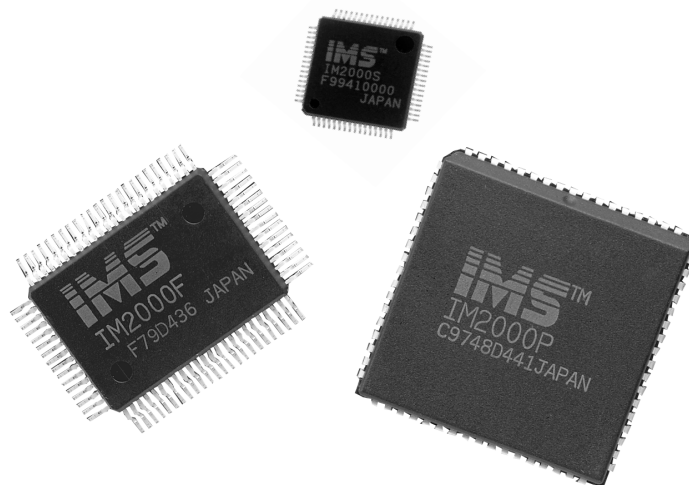

## General Disclaimer

The information in this book has been carefully checked and is believed to be accurate; however, no responsibility is assumed for inaccuracies. Intelligent Motion Systems, Inc., reserves the right to make changes without further notice to any products herein to improve reliability, function or design. Intelligent Motion Systems, Inc., does not assume any liability arising out of the application or use of any product or circuit described herein; neither does it convey any license under its patent rights of others. Intelligent Motion Systems and **IMS**<sup>™</sup> are trademarks of Intelligent Motion Systems, Inc.

Intelligent Motion Systems, Inc.'s general policy does not recommend the use of its products in life support or aircraft applications wherein a failure or malfunction of the product may directly threaten life or injury. Per Intelligent Motion Systems, Inc.'s terms and conditions of sales, the user of Intelligent Motion Systems, Inc., products in life support or aircraft applications assumes all risks of such use and indemnifies Intelligent Motion Systems, Inc., against all damages.

## Twenty-Four Month Limited Warranty

Intelligent Motion Systems, Inc., warrants its products against defects in materials and workmanship for a period of 24 months from receipt by the end-user. During the warranty period, IMS will either, at its option, repair or replace products which prove to be defective.

### EXCLUSIONS

The above warranty shall not apply to defects resulting from: improper or inadequate handling by customer; improper or inadequate customer wiring; unauthorized modification or misuse; or operation outside of the electrical and/or environmental specifications for the product.

### OBTAINING WARRANTY SERVICE

To obtain warranty service, a returned material authorization number (RMA) must be obtained from customer service at (860) 295-6102 before returning product for service. Customer shall prepay shipping charges for products returned to IMS for warranty service and IMS shall pay for return of products to customer. However, customer shall pay all shipping charges, duties and taxes for products returned to IMS from another country.

### WARRANTY LIMITATIONS

IMS makes no other warranty, either expressed or implied, with respect to the product. IMS specifically disclaims the implied warranties of merchantability and fitness for a particular purpose. Some jurisdictions do not allow limitations on how long an implied warranty lasts, so the above limitation or exclusion may not apply to you. However, any implied warranty of merchantability or fitness is limited to the 24-month duration of this written warranty.

### EXCLUSIVE REMEDIES

If your product should fail during the warranty period, call customer service at (860) 295-6102 to obtain a returned material authorization number (RMA) before returning product for service. Please include a written description of the problem along with contact name and address. Send failed product to: Intelligent Motion Systems, Inc., 370 N. Main St. Marlborough, Connecticut 06447. Also enclose information regarding the circumstances prior to product failure.

## Contents

### **Section 1**

#### ***Introduction to the IM2000***

|                             |   |
|-----------------------------|---|
| Section Overview .....      | 3 |
| The IM2000 .....            | 3 |
| Features And Benefits ..... | 4 |
| Block Diagram .....         | 4 |

### **Section 2**

#### ***Hardware Specifications***

|  |   |
|--|---|
| Section Overview .....                             | 5 |
| Mechanical Specifications .....                    | 5 |
| IM2000F - 80 Pin QFP .....                         | 5 |
| IM2000P - 68 Pin PLCCC .....                       | 6 |
| IM2000S - 64 Pin<br>Ultra-Small QFP .....          | 6 |
| Electrical & Environmental<br>Specifications ..... | 7 |
| IM2000 Pin Description .....                       | 8 |

### **Section 3**

#### ***Operation of the IM2000***

|   |    |
|---|----|
| Section Overview .....                                    | 9  |
| Protection Inputs .....                                   | 9  |
| Microstep Select (MSEL) Inputs ..                         | 10 |
| Step/Direction Inputs .....                               | 10 |
| Chip Select (CSEL) Input .....                            | 11 |
| Full Step Output .....                                    | 11 |
| Dual PWM .....  | 11 |
| Recirculating .....                                       | 11 |
| Non-Recirculating .....                                   | 11 |
| Fixed PWM Type .....                                      | 12 |
| Power Control Outputs .....                               | 12 |
| Current Control .....                                     | 13 |
| Digital Current Control .....                             | 13 |
| Automatic Current Reduction .....                         | 13 |
| Example Application of the<br>Power Control Outputs ..... | 13 |
| Chopping Oscillator .....                                 | 14 |
| Reset .....   | 14 |
| External Lookup Tables .....                              | 14 |
| Buss/Stand-alone Mode .....                               | 15 |
| Typical Application .....                                 | 16 |

# SECTION 1

## Introduction to the IM2000

### Section Overview

This section will introduce the user to the feature set provided by the IM2000 Microstepping controller ASIC. The following subsections are contained:

- The IM2000 Described
- Features and Benefits
- Block Diagram

### The IM2000

The IM2000 is a high performance microstepping step motor controller that incorporates a sine/cosine signal generator, anti-resonance circuitry, PWM current control and much more in one monolithic IC. The IM2000 combines hardware intense functions together with innovative features to provide designers with a powerful yet simple solution for their high volume OEM products.

Never before has any motion product integrated all the digital control into one monolithic IC. This high degree of integration can significantly reduce design time as well as driver size.

Beyond the integration of a complete microstepping control system, the IM2000 has unique features that give designers unprecedented control over motor movement. These features include 14 selectable resolutions (in both decimal and binary) that can be changed at any time without motor movement interruption. There is no need to reset the controller. This allows the user to rapidly move long distances, yet precisely position the motor at the end of travel without the need or expense of a complex controller.

Another valuable feature is an “On Full Step” output which indicates when the motor is at an electrical full step. This output can be used to reduce the overhead needed to track position when making long moves.

The development of proprietary circuits has minimized ripple current, while maintaining a 20 KHz chopping rate. This prevents additional motor heating that is common with drivers requiring higher chopping rates. Now low inductance stepper motors can be used to improve high speed performance and peak system efficiency.

The IM2000 needs only clock and direction inputs to control the motor and will interface directly to discrete bridges or common monolithic bridge ICs.

Designers can now place drivers directly on their PC boards with all the necessary control in either a 68 pin PLCC package (IM2000P), an 80 pin QFP package (IM2000F), or an ultra small 64 pin QFP package (IM2000S).

Size, price and time-to-market are three crucial aspects in today’s competitive markets and the IM2000 offers the ability to reduce all three.

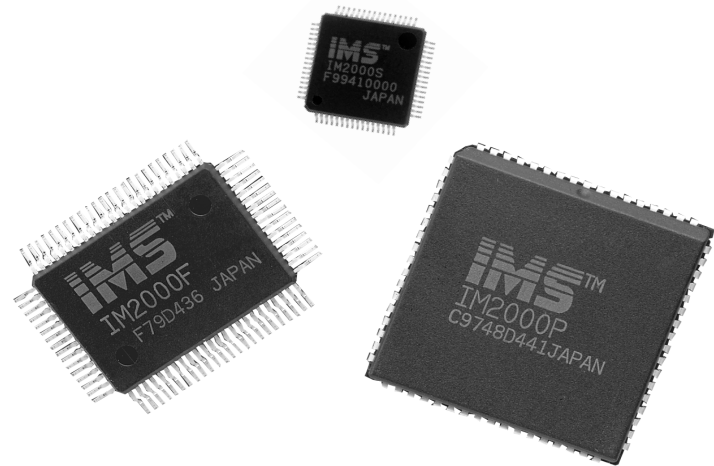
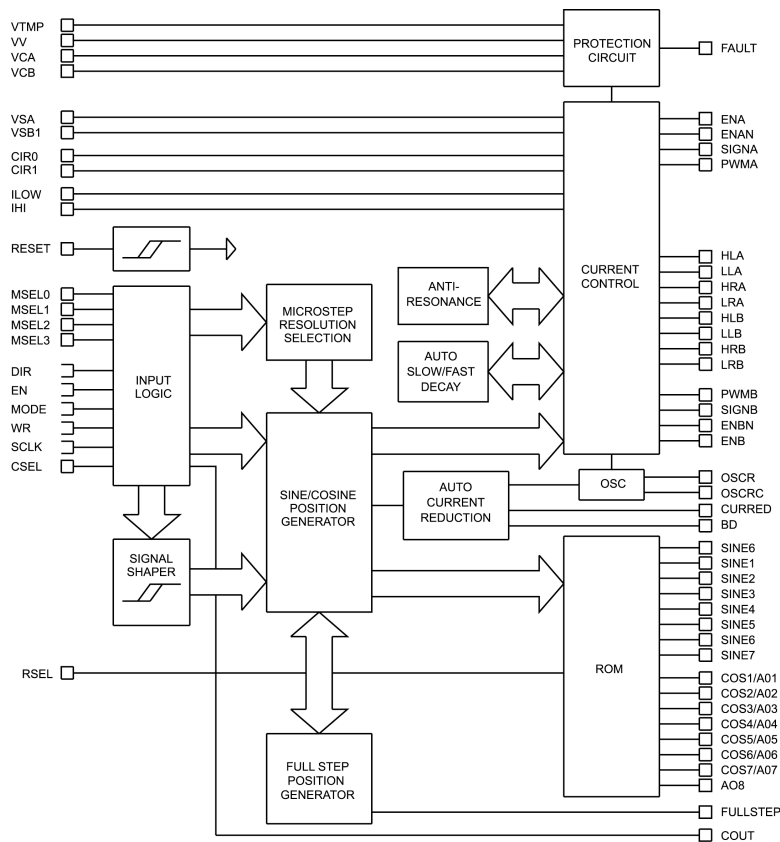

**Figure 1.1: The IM2000F, IM2000S and IM2000P, Shown Left to Right**

# Features And Benefits

- Complete Microstepping Control System in the following packages:
  - 68 Pin PLCC (IM2000P)
  - 80 Pin QFP (IM2000F)
  - 64 Pin QFP (IM2000S)
- Up to 10MHz Step Clock Rate
- Internal Sine/Cosine Generator
- PWM Phase Current Control
- Minimal External Components
- Automatic Current Reduction
- 14 Selectable Resolutions — Both in Decimal and Binary
- Number of Microsteps Per Step can be Changed On-The-Fly Without Motor Movement Interruption
- Up to 51,200 Steps/Rev
- Standalone or Buss Modes
- Single 5V Power Supply
- Short Circuit and Over Temperature Protection Inputs
- Fault Output
- On Full Step Output
- Anti-Resonance

# Block Diagram



**Figure 1.1: IM2000 Block Diagram**

# SECTION 2

## Hardware Specifications

### Section Overview

This section covers the hardware specifications of the IM2000. Covered are:

- Mechanical Specifications
- Electrical Specifications
- Pin Description

### Mechanical Specifications

#### IM2000F - 80 Pin QFP

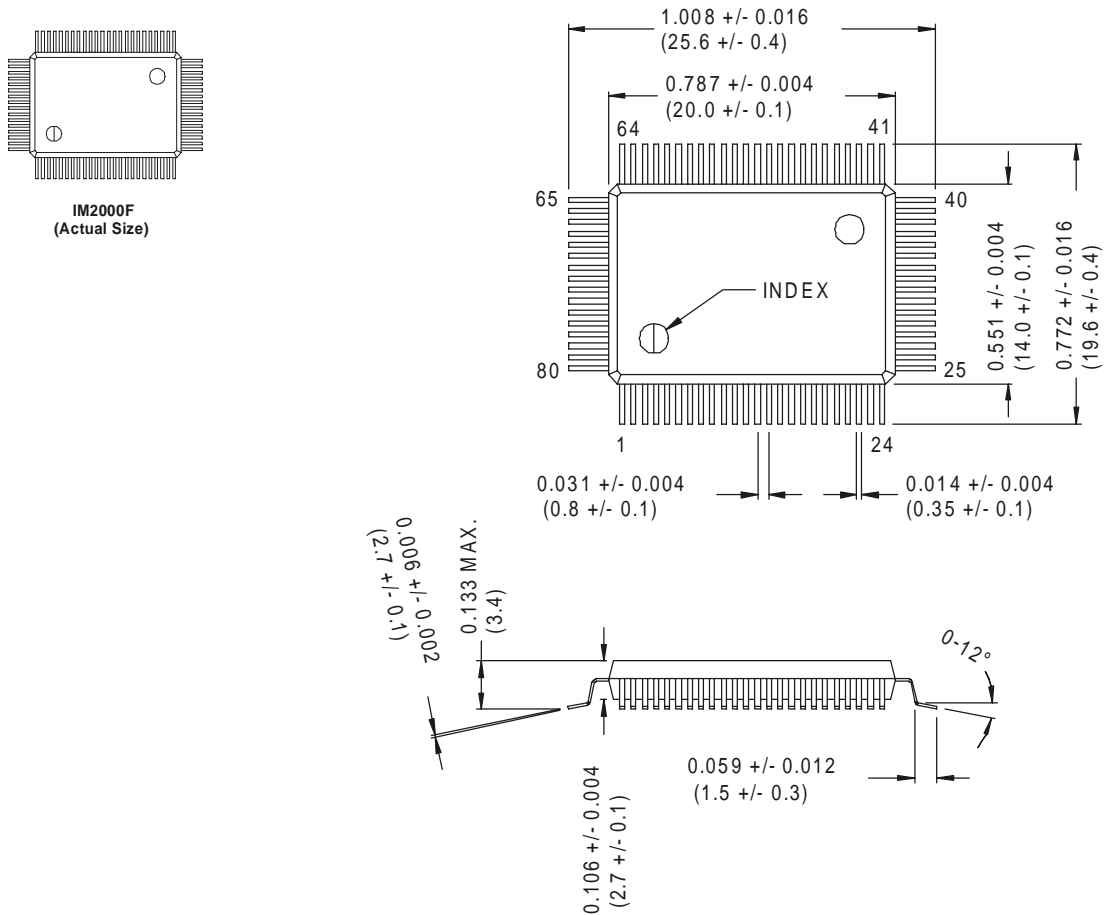
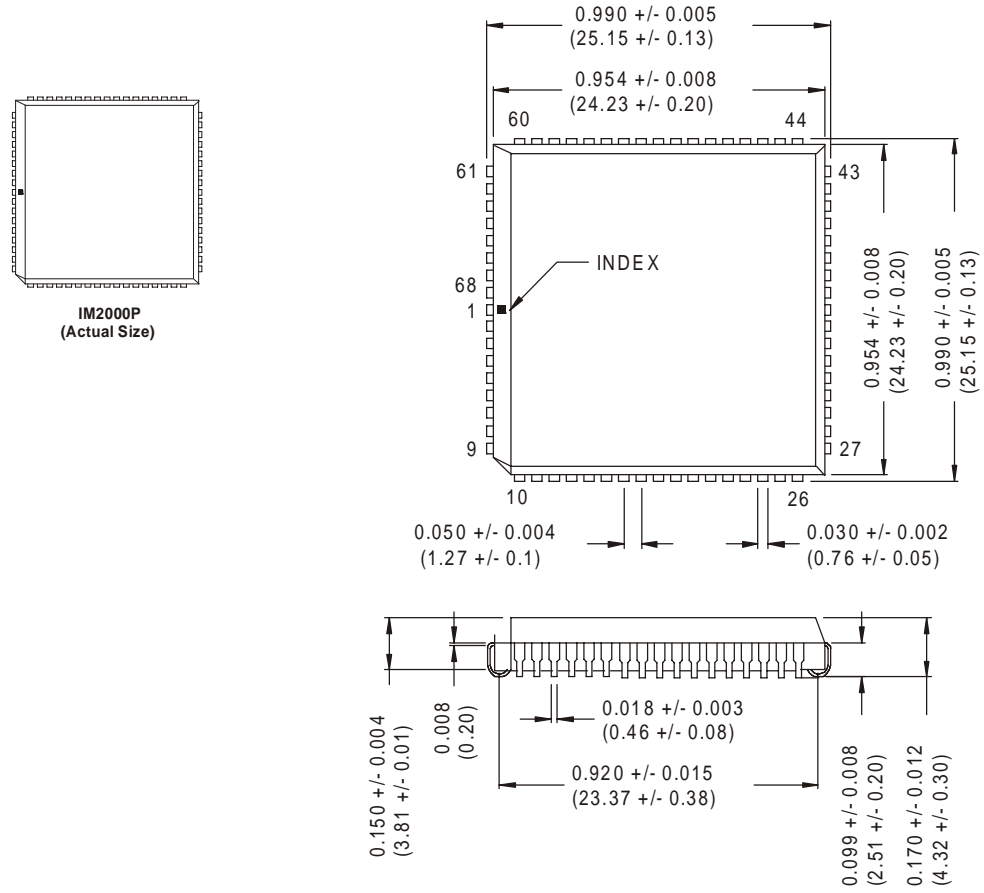

Figure 2.1: IM2000F Mechanical Specifications

# IM2000P - 68 Pin PLCC



**Figure 2.2: IM2000P Mechanical Specifications**

# IM2000S - 64 Pin Ultra-Small QFP

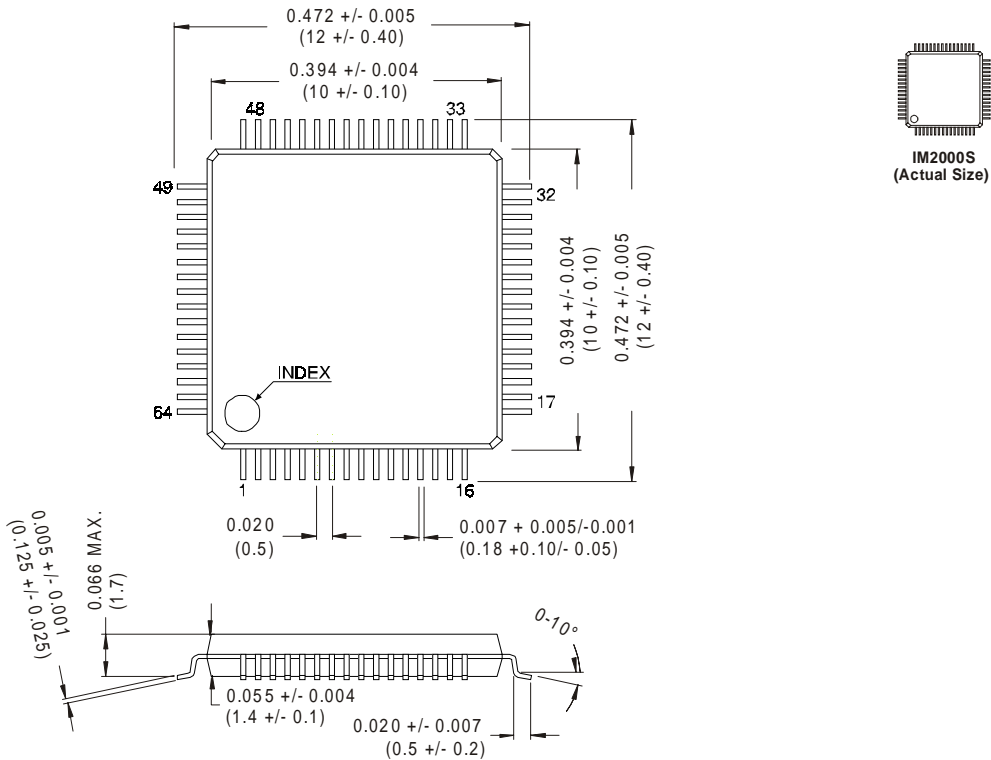

**Figure 2.3: IM2000S Mechanical Specifications**

# Electrical & Environmental Specifications

Test Condition:  $V_{DD} = +5.0 \pm 10\%$ ,  $T_{OPR} = 25\text{ }^{\circ}\text{C}$

| Symbol   | Parameter  | Conditions        | Min.           | Typical | Max.           | Units |
|----------|--|-------------------|----------------|---------|----------------|-------|
| $V_{IL}$ | Low level input voltage                          |                   |                |         | 0.8            | V     |
| $V_{IH}$ | High level input voltage                         |                   | 2.0            |         |                | V     |
| $V_{T+}$ | Schmitt trigger positive going threshold voltage | $V_{DD} = 5.0$    |                | 3.0     |                | V     |
| $V_{T-}$ | Schmitt trigger negative going threshold voltage | $V_{DD} = 5.0$    | 0.6            |         |                | V     |
| $V_H$    | Schmitt trigger hysteresis voltage               | $V_{DD} = 5.0$    | 0.1            |         |                | V     |
| $I_{IL}$ | Low level input current                          | $V_{IN} = V_{SS}$ |                |         | 1.0            | mA    |
| $I_{IH}$ | High level input current                         | $V_{IN} = V_{DD}$ |                |         | 1.0            | mA    |
| $V_{OL}$ | Low level output voltage                         |                   |                |         | $V_{SS} + 0.4$ | V     |
| $V_{OH}$ | High level output voltage                        |                   | $V_{DD} - 0.4$ |         |                | V     |
| $I_{OL}$ | Low level output current                         |                   |                |         | -6.0           | mA    |
| $I_{OH}$ | High level output current                        |                   |                |         | 3.0            | mA    |
| $I_{CC}$ | Supply current                                   |                   |                |         |                | mA    |

**Table 2.1: DC Electrical Specifications**

| Symbol    | Parameter               | Min. | Typical | Units |
|-----------|-------------------------|------|---------|-------|
| $t_{RW}$  | RESET pulse width       | 200  |         | nS    |
| $t_S$     | MSEL, SCLK setup time   |      | 100     | nS    |
| $t_{SW}$  | SCLK pulse width        |      | 10      | nS    |
| $t_{WR}$  | WR pulse width          |      | 20      | nS    |
| $t_{WH}$  | Data hold time after WR | 0    |         | nS    |
| $f_{PWM}$ | PWM chopping frequency  |      | 20      | KHz   |
| $f_{CLK}$ | SCLK input frequency    |      | 10      | MHz   |

**Table 2.2: AC Electrical Specifications**

| Parameter         | Symbol    | Limits                           | Units              |
|-------------------|-----------|----------------------------------|--------------------|
| DC Supply Voltage | $V_{DD}$  | $V_{SS} - 0.3$ to $+7.0$         | V                  |
| Input Voltage     | $V_{IN}$  | $V_{SS} - 0.3$ to $V_{DD} + 0.3$ | V                  |
| Output Voltage    | $V_{OUT}$ | $V_{SS} - 0.3$ to $V_{DD} + 0.3$ | V                  |
| Storage Temp.     | $T_{STG}$ | -65 to +150                      | $^{\circ}\text{C}$ |

**Table 2.3: Absolute Maximum Ratings**

| Parameter         | Symbol    | Min.     | Typ | Max.     | Units              |
|-------------------|-----------|----------|-----|----------|--------------------|
| DC Supply Voltage | $V_{DD}$  | 4.5      | 5.0 | 5.5      | V                  |
| Input Voltage     | $V_{IN}$  | $V_{SS}$ |     | $V_{DD}$ | V                  |
| Operating Temp.   | $T_{OPR}$ | -20      |     | 85       | $^{\circ}\text{C}$ |

**Table 2.4: Recommended Operating Conditions**

# IM2000 Pin Description

| 80 Pin QFP (F)    | 68 Pin PLCC (P) | 64Pin QFP (S)  | NAME                         | Pin Function   |
|-------------------|-----------------|----------------|------------------------------|--|
| 56                | 4               | 59             | SCLK                         | Step clock input. A positive going edge on this input will advance the motor one increment (the size of the increment is dependent on the microstep select inputs).  |
| 48                | 65              | 52             | RSEL                         | ROM select input. When low, this input selects the internal sine/cosine ROM. When high, AD0-AD8 are selected for use with an external lookup table.  |
| 54                | 2               | 57             | RESET                        | Reset input. When low, this input will reset the IM2000 (PWM, Enable, and Full Bridge outputs will be disabled). When released, the controller will be at its initial state (sine at 0, cosine at peak).   |
| 57                | 5               | 60             | DIR                          | Direction input. This input is used to change the direction of the motor. Physical direction also depends on the connection of the motor windings.   |
| 49                | 66              | 53             | CSEL                         | Clock select input. When low, the SCLK input will be directed to the internal sine/cosine generator independent of the level of the EN input. When high, the SCLK input will be directed to the COUT output when the EN input is low and, conversely, to the internal sine/cosine generator when the EN input is high. |
| 58                | 6               | 61             | EN                           | Enable input. When low, this input will enable/disable the PWM and full bridge output signals.   |
| 59                | 7               | 62             | FSTEP                        | On fullstep output signal. This active low output indicates when the IM2000's sine & cosine outputs are positioned on a full step.   |
| 61                | 8               | 63             | FAULT                        | Fault output signal. This active high output indicates when a fault has occurred. It will stay active until the IM2000 is reset.   |
| 62                | 9               | 64             | WR                           | Write input. When the IM2000 is configured in the buss mode, this input is used to latch in the microstep select, enable, and direction inputs.  |
| 63                | 10              | 1              | MODE                         | Mode select input. This input is used to configure the IM2000 in a stand alone or buss mode.   |
| 40, 65            | 58, 12          | 45, 2          | PWMA, PWMB                   | Phase A and Phase B pulse width modulated output signals. These outputs can be used to control the phase currents in common PWM type power sections.   |
| 38, 67            | 57, 13          | 44, 3          | SIGNA, SIGNB                 | Sign of A and sign of B output signals. These outputs indicate the sign of the sine and the sign of the cosine.  |
| 36, 69            | 55, 15          | 43, 4          | ENA, ENB                     | Phase A and Phase B enable output signals. These active high outputs, which work in conjunction with the enable input of PIN 6, can be used to enable/disable the power section of the driver.   |
| 37, 68            | 56, 14          | —              | ENAN, ENBN                   | Phase A and Phase B enable NOT output signals. These active low outputs, which work in conjunction with the enable input of PIN 6, can be used to enable/disable the power section of the driver.  |
| 30, 31, 34, 35    | 50, 51, 53, 54  | 38, 39, 41, 42 | HRA, LRA, LLA, HLA           | Phase A high side and low side full bridge control signals. These outputs can be used to control discrete P-N or N-N full bridge sections or half and full bridge IC's.  |
| 70, 71, 74, 75    | 16, 17, 19, 20  | 5, 6, 8, 9     | HLB, LLB, LRB, HRB           | Phase B high side and low side full bridge control signals. These outputs can be used to control discrete P-N or N-N full bridge power sections or half and full bridge IC's.  |
| 78, 80, 1-4, 6, 7 | 23-30           | 12-19          | COS0-COS7                    | Cosine waveform output signals for Phase B.  |
| 18, 19, 21-25, 27 | 40-47           | 28-35          | SIN7-SIN0                    | Sine waveform output signals for Phase A.  |
| 42                | 60              | 47             | IHI                          | Polarity select input for active high or active low high side full bridge control outputs.   |
| 41                | 59              | 46             | ILOW                         | Polarity select input for active high or active low low side full bridge control outputs.  |
| 28, 77            | 48, 22          | 36, 11         | VSA, VSB                     | Phase A and Phase B current sense inputs.  |
| 29, 76            | 49, 21          | 37, 10         | OVCA, OVCB                   | Phase A and Phase B over current/short circuit protection inputs.  |
| 9                 | 32              | 20             | CURRED                       | Automatic current reduction output signal. This active high output is used to automatically reduce the driver output current 1 second after the last step clock input.   |
| 11, 12            | 34, 35          | 22, 23         | OSCRC, OSCR                  | Resistor/capacitor inputs for on-board PWM oscillator.   |
| 14                | 36              | 24             | OVV                          | Over voltage protection input.   |
| 16                | 38              | 26             | OVTMP                        | Over temperature protection input.   |
| 15, 55            | 3, 37           | 25, 58         | VCC                          | Supply voltage.  |
| 10, 32, 50, 72    | 18, 33, 52, 67  | 7, 21, 40, 54  | GND                          | Ground.  |
| 43, 44, 46, 47    | 18, 33, 52, 67  | 48-51          | MSEL0-MSEL3                  | Microstep resolution select inputs. These inputs are used to select the number of microsteps per full step. The available resolutions (microsteps/step) are: 2, 4, 5, 8, 10, 16, 25, 32, 50, 64, 125, 128, 250, 256.   |
| 78, 80, 1-4, 6-8  | 23-31           | 12-19          | AD0-AD8 (P/F)<br>AD0-AD7 (S) | Address 0 – Address 8 (Address 0 - Address 7 on IM2000S) . These outputs are used in conjunction with external lookup tables for user supplied sine and cosine curves.   |
| 17                | 39              | 27             | COUT                         | SCLK output. This output is dependent on the CSEL and EN inputs.   |
| 51, 52            | 68, 1           | 55, 56         | CIR0, CIR1                   | PWM circulation select inputs. These inputs are used to select whether or not the PWM will be in a recirculating or a non-recirculating mode, or an automatic recirculating and non-recirculating mode.  |
| 64                | 11              | —              | BD                           | Binary/Decimal select output. This output is used in conjunction with AD0-AD8 when using outside lookup tables. This output is used to choose between binary or decimal encoded tables.  |

**Table 2.5: IM2000 Pin Description**



# SECTION 3

## Operation of the IM2000

### Section Overview

This section covers the operation of the various circuits contained within the IM2000 Microstepping Controller ASIC. These are:

- Protection Inputs
- Microstep Select (MSEL) Inputs
- Step/Direction Inputs
- Chip Select (CSEL) Input
- Full Step Output
- Dual PWM
- Power Control Outputs
- Controlling the Output Current
- Chopping Oscillator
- Reset Input
- External Look-up Table
- Buss/Standalone Mode

### Protection Inputs

The IM2000 has four inputs which will disable the PWM and driver control outputs to protect against external faults. These inputs include:

- Over Temperature
- Phase A and Phase B Short Circuit
- Over Voltage

All four inputs are buffered using Schmitt triggered buffers and are internally AND'ed together. These inputs may be used independently or tied together for wired OR'ed protection circuits. Unused inputs must be tied to a logic HIGH state.

Upon detection of a fault condition the IM2000 will latch the condition and set the fault output pin to a logic HIGH state. At this time the phase control outputs, phase enable outputs and PWM are disabled. The IM2000 must be reset by either pulling the reset input LOW, or cycling power to clear the fault condition and re-enable the PWM and driver control outputs. Figures 3.1 and 3.2 illustrate possible application/interface of the overcurrent and over temperature inputs.

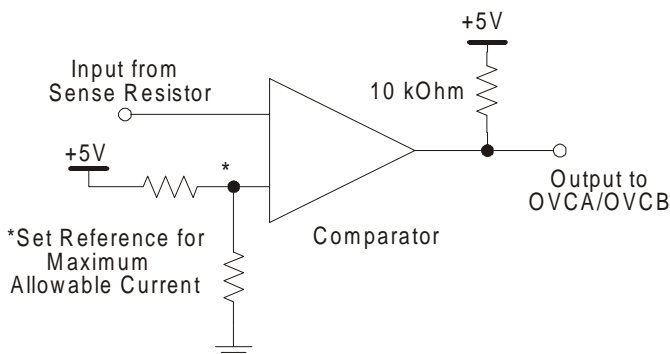

**Figure 3.1: Overcurrent Protection Example**

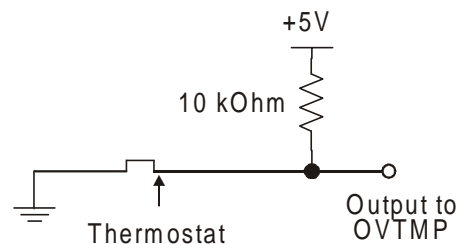

**Figure 3.2: Thermal Protection Example**

# Microstep Select (MSEL) Inputs

The Microstep Select inputs are used to select the number of fractional steps per full step that the IM2000 will output to the motor. These inputs are buffered using Schmitt trigger buffers to increase noise immunity. There are 14 different selections built into the IM2000. Table 3.1 shows the list of resolutions and their relationship to the state of the MSEL inputs.

A unique feature of the IM2000 is the ability to change resolutions at any time. A resolution change can occur whether the motor is being clocked or is at rest. The change will not take place until the rising edge of the next step clock input. At this time, the new resolution is latched and implemented before the step clock pulse takes affect.

If a resolution is chosen such that the sine/cosine output of the IM2000 would not land on an electrical fullstep of the motor, then the IM2000 will automatically align itself to the full step position on the step clock pulse that would have caused the motor to rotate past the full step. The step clock pulses, from that point forward will be equal to the selected resolution. This feature allows the user to switch resolutions at any time without having to keep track of sine/cosine location. The user can now easily track position utilizing the full step output signal.

The capability of changing resolutions on-the-fly allows for high speed slewing where bandwidth is limited, as is the case with many single chip microcontrollers. The user may switch to a coarser resolution during long moves for increased speed, then change to a finer resolution for precise positioning at the end of travel.

**Truth Table: Resolution Select Inputs - Binary Mode**

| Microsteps per Full Step | MSEL 3 | MSEL 2 | MSEL 1 | MSEL 0 |
|--------------------------|--------|--------|--------|--------|
| 2                        | 0      | 0      | 0      | 0      |
| 4                        | 0      | 0      | 0      | 1      |
| 8                        | 0      | 0      | 1      | 0      |
| 16                       | 0      | 0      | 1      | 1      |
| 32                       | 0      | 1      | 0      | 0      |
| 64                       | 0      | 1      | 0      | 1      |
| 128                      | 0      | 1      | 1      | 0      |
| 256                      | 0      | 1      | 1      | 1      |

**Truth Table: Resolution Select Inputs - Decimal Mode**

| Microsteps per Full Step | MSEL 3 | MSEL 2 | MSEL 1 | MSEL 0 |
|--------------------------|--------|--------|--------|--------|
| 5                        | 1      | 0      | 0      | 0      |
| 10                       | 1      | 0      | 0      | 1      |
| 25                       | 1      | 0      | 1      | 0      |
| 50                       | 1      | 0      | 1      | 1      |
| 125                      | 1      | 1      | 0      | 0      |
| 250                      | 1      | 1      | 0      | 1      |

**Invalid Microstep Resolution Settings**

| Microsteps per Full Step | MSEL 3 | MSEL 2 | MSEL 1 | MSEL 0 |
|--------------------------|--------|--------|--------|--------|
| xxxxxxx                  | 1      | 1      | 1      | 0      |
| xxxxxxx                  | 1      | 1      | 1      | 1      |

**Table 3.1: Microstep Resolution Settings**

# Step/Direction Inputs

The IM2000 contains a built-in sine/cosine generator used for the generation of Phase A and Phase B position reference. This digitally encoded 9 bit sine and 9 bit cosine signal is directly fed into a digital-to-analog converter.

The step clock (SCLK) and direction (DIR) inputs are buffered using Schmidt triggered buffers for increased noise immunity and are used to increment or decrement the sine/cosine position generator. The position generator is updated on the rising edge of the step clock input. It will increment or decrement by the amount specified by the microstep resolution select (MSEL) inputs.

The direction (DIR) input determines the direction of the position generator and hence the direction of the motor. The DIR input is synchronized to the SCLK input. On the rising edge of the SCLK input, the state of the DIR input is latched in. The position generator will then look to see if there has been a change in direction and implement that change before executing the next step. By utilizing this method to implement the direction change, the noise immunity is greatly increased and no physical change in the motor occurs if the direction line is toggled prior to the step clock input.

The enable/disable input does not affect the step clock input. The sine/cosine generator will continue to update if a signal is applied to the step clock input. The IM2000 outputs both sine and cosine data simultaneously when applying a step clock input. Dual internal look-up tables are used to output a unique position for every step clock input to enhance system performance.

## Chip Select (CSEL) Input

The CSEL input is used to select a number of functions that are implemented using the MSEL0 and MSEL1 inputs. If CSEL is low, or not connected, MSEL0 and MSEL1 will function as microstep select lines as explained earlier.

If CSEL is high, MSEL0 and MSEL1 may be used to:

- Reset the IM2000.
- Disable the PWM and driver control outputs.
- Channel the Step Clock Input to COUT.

| CSEL Settings |       |                  |
|---------------|-------|------------------|
| MSEL1         | MSEL0 | Function         |
| 0             | 0     | SCLK to COUT     |
| 0             | 1     | SCLK to COUT     |
| 1             | 0     | Reset Controller |
| 1             | 1     | Disable Outputs  |

**Table 3.2: Chip Select Settings**

The relationship between the MSEL0 and MSEL1 inputs and these special functions are illustrated in Table 3.2.

## Full Step Output

This active high output indicates when the motor is electrically on a full step (the poles of the motor are aligned). This occurs when either the sine or cosine outputs are at zero.

This signal may be used to greatly reduce the overhead needed to monitor position, decreasing the number of counts needed to track position. By utilizing the full step output it is no longer necessary to keep track of the number of microsteps between steps on moves until the last fractional step. With the full step output, it is possible to track position as a combination of full steps plus the number of microsteps occurring after the last full step.

In the case of long moves at high resolutions this feature will reduce the position counter size and the overhead associated with updating/monitoring the position counter.

## Dual PWM

The IM2000 contains a unique dual PWM circuit that efficiently and accurately regulates the current in the windings of a two phase stepping motor. The internal PWM accomplishes this by using an alternating recirculating/non-recirculating mode to control the current.

### Recirculating

In a recirculating PWM, the current in the windings is contained within the output bridge while the PWM is in its OFF state (after the set current is reached). This method of controlling the current is efficient when using low inductance motors, but lacks response because of its inability to remove current from the windings on the downward cycle of the sine/cosine wave (See Figure 3.3).

### Non-Recirculating

In a non-recirculating PWM, the current flows up through the bridge and back to the supply in the OFF phase of the cycle. This method of controlling current allows for much better response but reduces efficiency and increases current ripple, especially in lower inductance motors (See Figure 4.3).

The IM2000's PWM utilizes the best features of both by combining recirculating and non-recirculating current control. On the rising edge of the sine/cosine waveform, the PWM will always be in a recirculating mode. This mode allows the driver to run at peak efficiency while maintaining minimum current ripple even with low inductance motors. On the downward cycle of the sine/cosine waveform, the PWM operates in a two part cycle. In the first part of its cycle the PWM

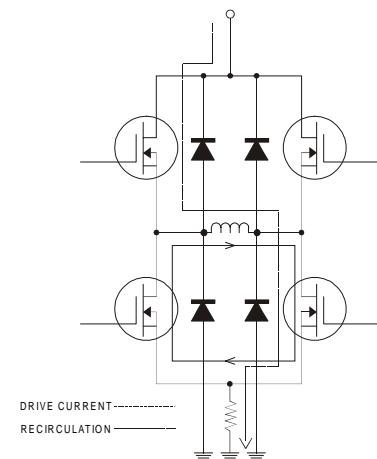

**Figure 3.3: Recirculating PWM**

is in a non-recirculating mode to pull current from the motor windings. In the second part of the cycle the PWM reverts back to recirculating mode to increase efficiency and reduce current ripple.

The IM2000 will automatically change the non-recirculating pulse widths to compensate for changes in supply voltage and accommodate a wide variety of motor inductances. This method also allows for the use of very low inductance motors, while utilizing a 20kHz chopping rate which reduces motor heating but maintains high efficiency and low current ripple.

### Fixed PWM Type

The internal PWM in the IM2000 may also be placed in a fixed recirculating or non-recirculating mode by the use of the CIR0 and CIR1 inputs. The relationship between the states of the CIR0 and CIR1 inputs and the method of current control is shown in Table 3.3.

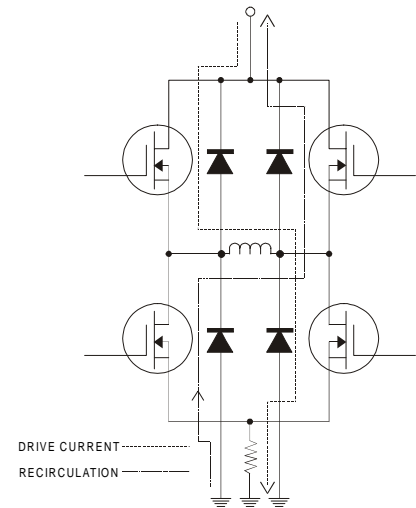

**Figure 3.4: Non-Recirculating PWM**

| PWM Current Control Modes |      |                                |
|---------------------------|------|--------------------------------|
| CIR1                      | CIR0 | PWM Type                       |
| 0                         | 0    | Auto-Recirculating             |
| 1                         | 0    | Fast Decay (Non-Recirculating) |
| 0                         | 1    | Slow Decay (Recirculating)     |
| 1                         | 1    | Fast Decay (Non-Recirculating) |

**Table 3.3: Current Control Mode Settings**

## Power Control Outputs

The relationship between the Sine\Cosine, Power Section Control and PWM outputs of the IM2000 is illustrated in Figure 3.5. When either the sine or cosine is at 0, the enable and all drive control outputs for that particular phase will be turned off to improve accuracy.

The inputs IHI and ILOW to the IM2000 are used to invert the polarity of the high side and low side driver control signals respectively. These inputs have no effect on the sign, EN, and PWM output signals.

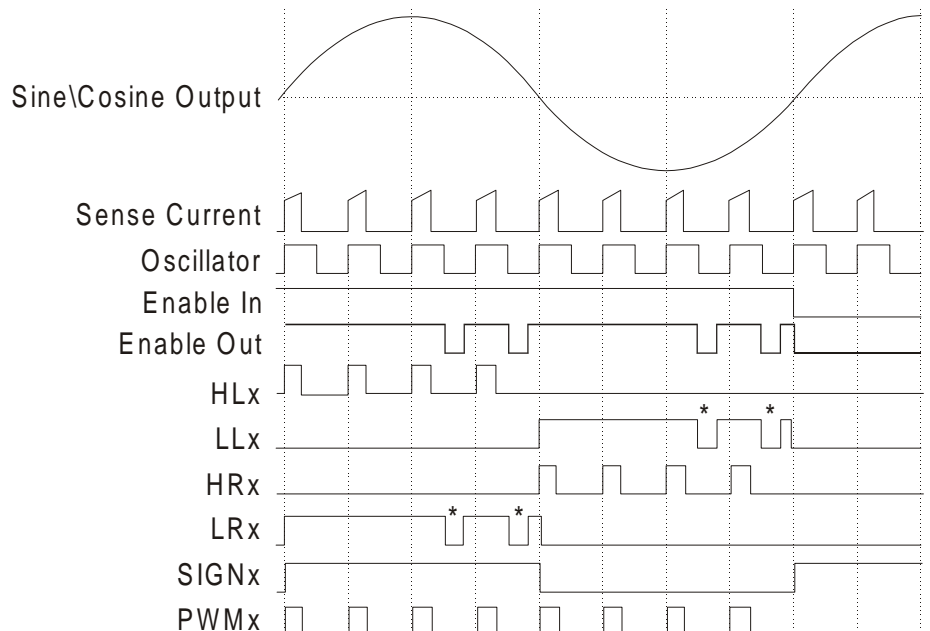

\*Fast decay period for auto decay mode.

**Figure 3.5: Power Control Output Relationships**

## Example Application of the Power Control Outputs

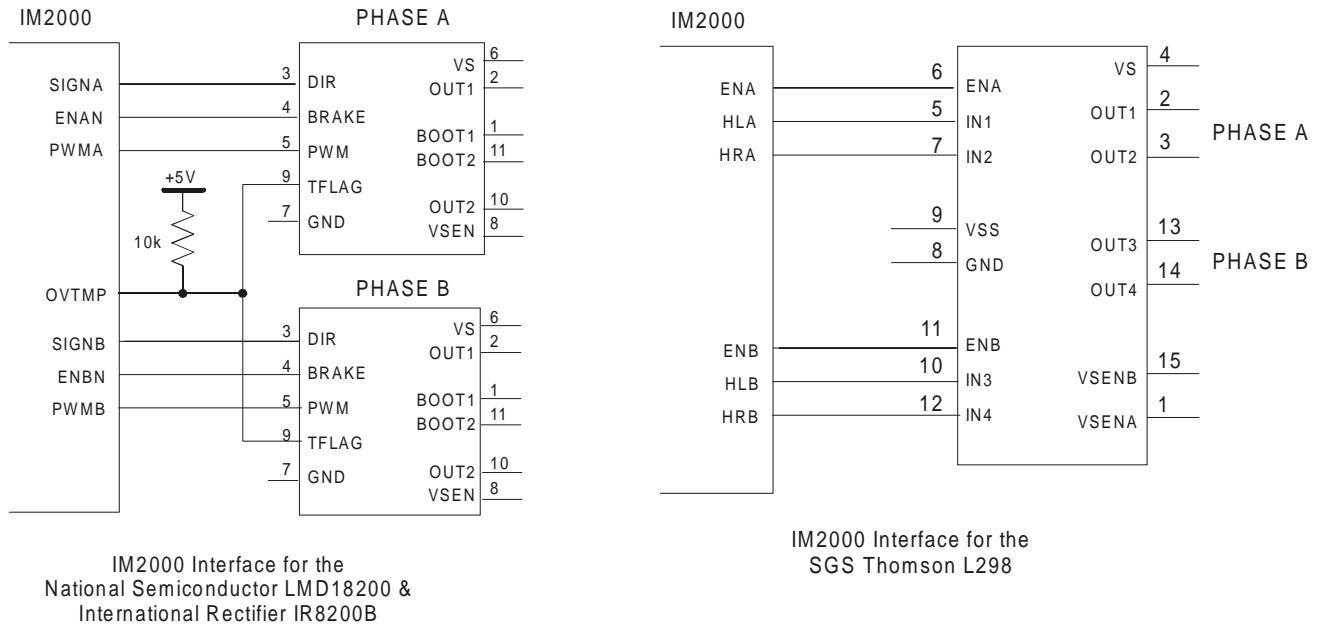

Figure 3.6: Power Control Output Interface Examples

## Current Control

### Digital Current Control

The schematic example shown in Figure 3.6 illustrates how the user might set up the 0 to 2V D/A reference to control the output current of the driver.

### Automatic Current Reduction

The IM2000 contains an auto-current reduction circuit which will automatically set the CURRED output HIGH approximately 1.5 seconds after the rising edge of the last step clock pulse. This output, coupled with a minimum of external components may be used to reduce the current in the windings when the motor is at a standstill.

The CURRED output will then be reset on the next rising edge of the step clock input. This feature can greatly reduce motor and driver heating. It may also increase power efficiency in systems not requiring full holding torque.

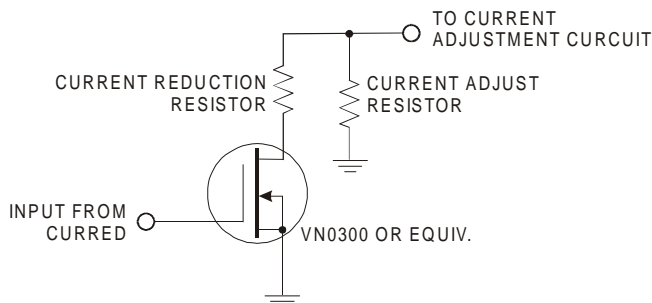

Figure 3.8: Automatic Current Reduction

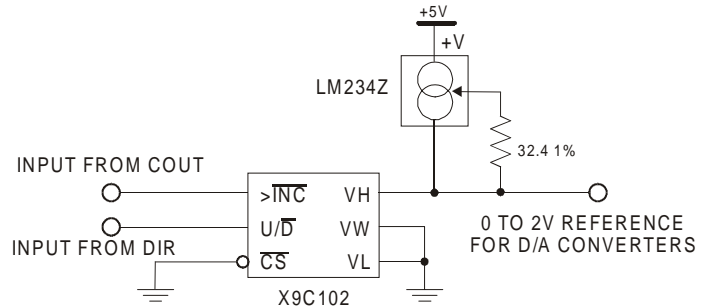

Figure 3.7: Digital Current Control Example

Note that although both phases are reduced by the same percentage when using the Automatic Current reduction feature, motor shaft movement may occur, depending on shaft positioning and load type.

# Chopping Oscillator

The IM2000 contains a built-in oscillator which is used to clock the internal pulse width modulator. The oscillator frequency is set by an external RC circuit.

While it is recommended to set the oscillator frequency to approximately 20kHz to reduce motor heating and maintain a frequency above the audible range, the internal oscillator can accommodate a wide range of frequencies. Figure 3.9 shows the relationship between the chopping frequency and the RC resistor component values. Note that the values shown were recorded using a fixed 1nF capacitor.

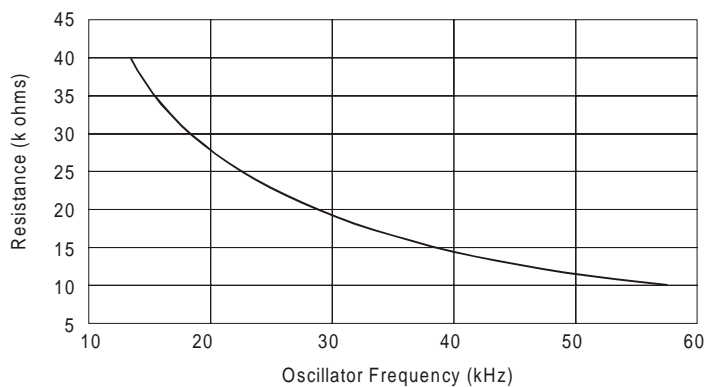

**Figure 3.9: Oscillator Frequency Settings**

# Reset

The reset input is a Schmitt triggered input used to initialize the IM2000. The IM2000 must be reset on power-up to ensure proper operation. In order to initialize the IM2000, the reset input must be held in a logic LOW state for a minimum of 200ns.

Upon reset the IM2000 is configured such that Phase A is at 0 and Phase B is full on and in the positive half cycle. The fault output is cleared as long as no fault condition is active on any of the protection inputs. The current reduction output will set approximately 1.5 seconds following the release of the reset input if no step clock input is detected.

The microstep resolution select lines and the direction input are latched on the rising edge of the reset input. This will occur in either the buss or stand-alone mode of operation.

# External Lookup Table

The IM2000 allows the use of an external lookup table to generate the Phase A and Phase B waveforms. This is accomplished by the use of the RSEL input. By using an external lookup table the user can tailor the wave shapes to meet individual needs.

When the RSEL input is in a logic LOW state, the internal lookup tables are selected and the sine and cosine information is accessed internal to the IM2000. When RSEL is HIGH a nine bit address is output to AD0 - AD8. This nine bit address will then increment or decrement depending on the state of the microstep resolution and direction inputs.

The IM2000 uses a unique approach in the generation of the address. First, nine bits are used instead of 8 to get the full 256 positions. Second, only a quarter of the sine and cosine waveforms need to be stored. The IM2000 will automatically reconstruct the entire waveform from this information. This means only 514 words need to be stored to generate the entire sine and cosine waveform for binary resolutions and 502 words for decimal resolutions. The IM2000 will automatically generate the sign and cosine signs and the full step output signal internally.

| External Lookup Table Example |                          |        |                          |
|-------------------------------|--------------------------|--------|--------------------------|
| Decimal                       |                          | Binary |                          |
| Step #                        | AD0-AD9<br>Decimal (Hex) | Step # | AD0-AD9<br>Decimal (Hex) |
| 0                             | 0 (0)                    | 0      | 0 (0)                    |
| 1                             | 50 (32)                  | 1      | 64 (40)                  |
| 2                             | 100 (64)                 | 2      | 128 (80)                 |
| 3                             | 150 (96)                 | 3      | 192 (C0)                 |
| 4                             | 200 (C8)                 | 4      | 256 (100)                |
| 5                             | 250 (FA)                 | 5      | 192 (C0)                 |
| 6                             | 200 (C8)                 |        |                          |

**Table 3.4: External Lookup Table Example Address Locations**

In reconstructing the sine and cosine waveforms using binary resolutions, the IM2000 addresses locations 0 - 255 to reconstruct the first quarter of the waveform. The 256<sup>th</sup> location represents the peak or start of the second quarter (i.e. sine = 1, cosine = 0). When using decimal resolutions, the IM2000 addresses locations 0 - 249 to reconstruct the first quarter of the waveform. The 250<sup>th</sup> location represents the peak or start of the second quarter. Table 3.4 shows the addresses generated by the IM2000 for a resolution of 5 microstep per step in decimal and 4 microsteps per step in binary selected by MSEL0 - MSEL3.

The BD output may be used to select between the binary and decimal lookup tables. The BD output follows the MSEL3 input and is latched and updated on the rising edge of the SCLK input. Figure 3.10 shows a block diagram utilizing external lookup tables

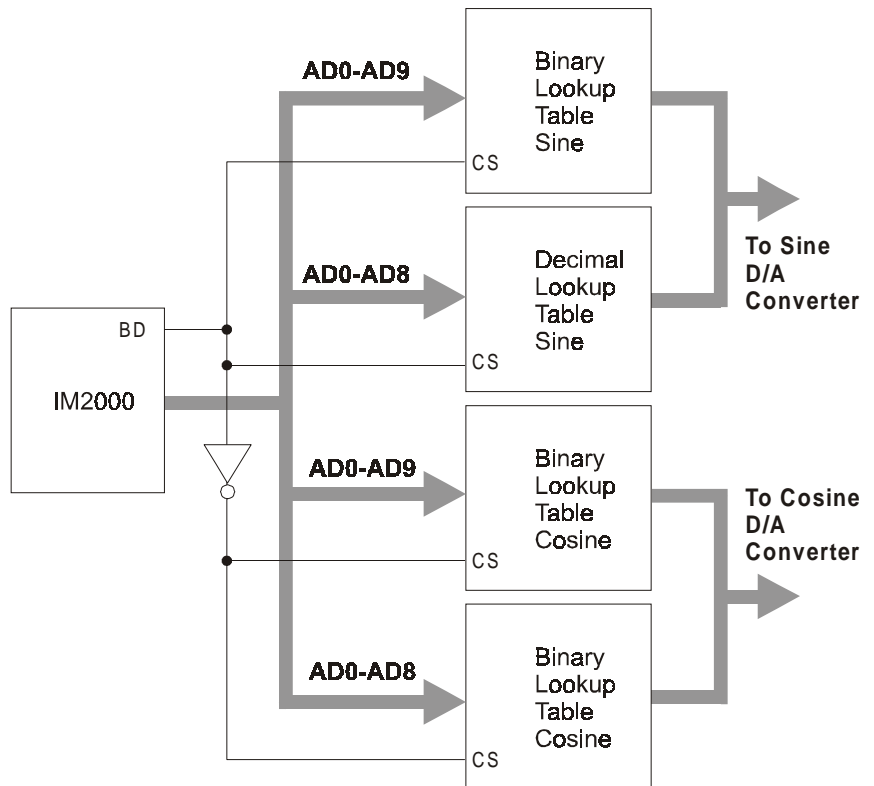

**Figure 3.10: External Lookup Table**

## Buss/Stand-alone Mode

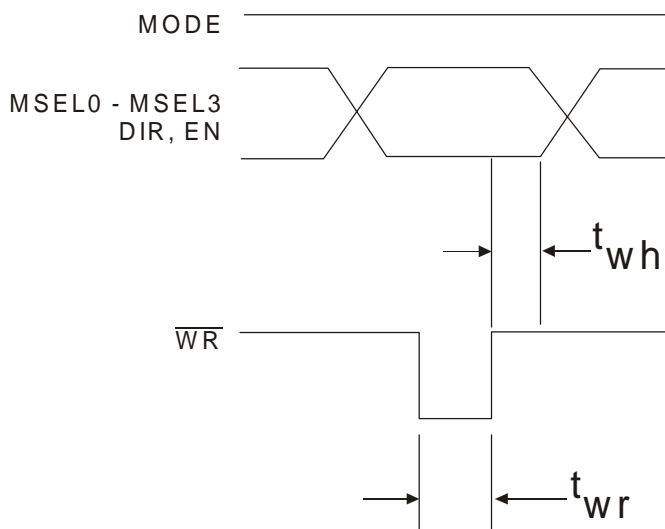

**Figure 3.11: WR Input Timing**

The IM2000 may be used either in stand-alone mode or tied directly to the data buss of a microprocessor/controller.

If the Mode input is HIGH, the IM2000 will be in stand-alone mode and MSEL0 - MSEL3 and DIR will be updated on the rising edge of the SCLK input. The EN input is not dependent on the SCLK input.

If the Mode input is LOW, the IM2000 will be in Buss Mode and MSEL0 - MSEL3, DIR and EN are latched into the IM2000 on the rising edge of the WR input. Figure 3.11 shows the timing diagram for the WR input.

# Typical Application

48V, 3 Amps (RMS)/Phase Microstepping Driver

Output Current (AMPS) = .002 x R1 (OHMS)

**NOTE:** Diodes may be needed on phase outputs depending on input voltage and phase currents used.

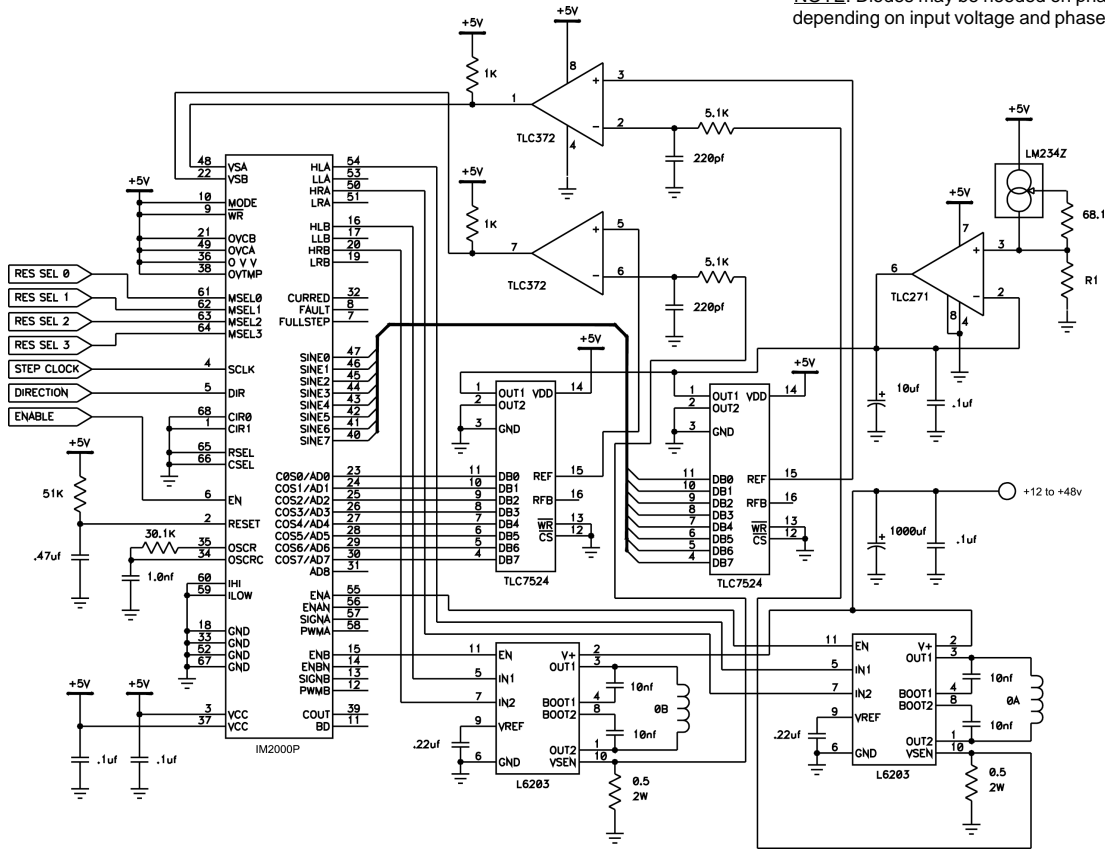

**IMS**™ INTELLIGENT MOTION SYSTEMS, INC.

*Excellence in Motion™*

370 North Main Street  
P.O. Box 457  
Marlborough, CT 06447  
U.S.A.

Phone: 860/295-6102  
Fax: 860/295-6107  
Email: [info@imshome.com](mailto:info@imshome.com)  
Web Site: <http://www.imshome.com>

## Western Region Sales Office

105 Copperwood Way, Suite H  
Oceanside, CA 92054

Sales  
Phone: 949/707-0156  
Fax: 949/707-0157  
Email: [wsales@imshome.com](mailto:wsales@imshome.com)  
Western Technical Support  
Phone: 760/966-3162  
Fax: 760/966-3165  
Email: [wtech@imshome.com](mailto:wtech@imshome.com)

## IMS Motor Sales

105 Copperwood Way, Suite H  
Oceanside, CA 92054  
Phone: 760/966-3162  
Fax: 760/966-3165  
Email: [motors@imshome.com](mailto:motors@imshome.com)

## IMS Europe

4 Quai Des Etroits  
69005 Lyon, France  
Phone: +33 4 72 56 51 13  
Fax: +33 4 78 38 15 37  
Email: [bmartinez@imshome.com](mailto:bmartinez@imshome.com)



IM2000 Operating Instructions  
V12.06.2000  
©2000 Intelligent Motion Systems, Inc.  
All Rights Reserved