

Specification For Approval

() Preliminary Specification

(●) Final Specification

Customer	LG-Nortel (LVP-1850)
Model	IM350DBN2A
Supplier	LG INNOTEK CO. LTD

Approved by LGE		Proposed by LG Innotek	
APPROVED BY	SIGNATURE	APPROVED BY	SIGNATURE
_____	_____	S.H. KIM	_____
DESIGNED BY	SIGNATURE	DESIGNED BY	SIGNATURE
_____	_____	Y. M. SHIN	_____

VER.0.6

Mar. 29 . 2007

Revision History

(A sheet refers to the sheet number after revision)

Date	Rev.	Sheet (New)	Item	Old	New	Reason
Jan/19/2006	0.1					Preliminary Specification Release
July/13/2006	0.2	Page 14	Pin Description	NC notation	<ul style="list-style-type: none"> • Pin 9 : SPI_CS • Pin 10 : SPI_Clock • Pin 11 : SPI_data Description filling up	• Pin function filling up
		Page 5	Absolute Maximum Rating	TBD	• Adding I/O Voltage	
July/13/2006	0.3	Page 6	Electrical Spec	TBD	• LCD input power up sequence	
July/28/2006	0.4	Page 8	Optical Spec		• Modifying the Optical specification	
Oct/30/2006	0.5	Page 8	Optical Spec		• Modifying the Optical specification	
Mar/29/2007	0.6	Page 8	Optical Spec		• Modifying the Optical specification	

— Table of Contents —

	Sheet
Revision History.....	2
1. General Description.....	4
2. General Features.....	4
3. Absolute Maximum Ratings	5
4. Electrical Specification.....	6–7
5. Optical Specification.....	8–12
6. Block Diagram	13
7. Pin Description	14
7.1. Input Signal and Power	14
7.2. Relation between Input Signal and Color	15
8. Register Values	16–20
9. AC Characteristics.....	21
9.1. Input Signal characteristics.....	21
9.2. Hardware reset timing	21
9.3. Output signal characteristics for digital input signal	22
10. SPI Timing Characteristics	23
11. Reliability and Inspection Standard	24
11.1 Reliability	24
11.1 Fault Judgment Criteria	24
11.3 Inspection Standard.....	25–27
12-1. Outline Dimension.....	28
12-2 Circuit Diagram	29
13. Packaging.....	30
13.1 Packing.....	30
13.2 Designation of Lot Mark	31

◆ Caution & Handling Precaution

- ▶ Safety
- ▶ Installation in Assembly
- ▶ Transportation And Storage

1. General Description

The **IM350DBN2A** model is a Color TFT(Main) supplied by LG Innotek.

This main Module has a 3.5 inch diagonally measured active display area with 240X320 resolution. Each pixel is divided into Red, Green and Blue sub-pixels and dots which are arranged in vertical stripes. Main LCD color is determined with 16.7M Color signal for each pixel.

The IM350DBN2A has been designed to apply the interface method that enables low power, high speed, and high contrast.

The IM350DBN2A is intended to support applications where thin thickness, wide viewing angle and low power are critical factors and graphic displays are important.

2. General Features

Item	Main display	Remark
Display Mode	Normally White, Transmissive LCD	
Viewing Direction	6 o'clock (In optimum contrast direction) good viewing direction is 12'oclock)	
Driving Method	A-Si TFT Active Matrix	
Input Signals	Digital 8bit RGB/24bit interface/CCIR656/CCIR601	
Outside Dimensions	74.64mm(W) X 60.96mm(H) X 0.6mm(D)	
Active area	70.08mm(H) x 52.56mm(V)	
Number of Pixels	320×RGB×240 Pixels	1)
Pixel Pitch	0.219mm(H) X 0.219mm(W)	1)
Pixel Arrangement	RGB stripes	1)
Driver IC	HX8218A(Source)/HX8615A(Gate)	

Note 1) Main Display

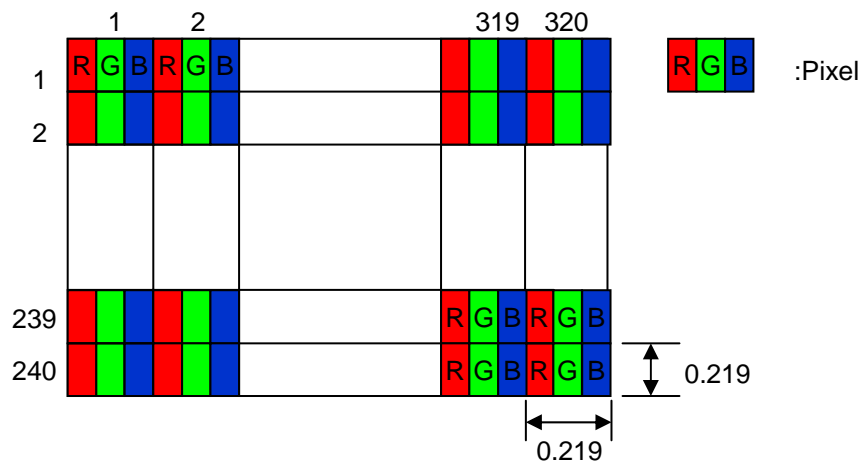

3. Absolute Maximum Ratings

The following are maximum values which, if exceeded, may cause operation or damage to the unit

ITEM	Symbol	Min.	Max.	Unit	Remark
Supply for Logic	V _{CC}	-0.3	7.0	V	
Supply for Analog	V _{DD}	-0.3	7.0	V	
Gate On Voltage	V _{GH}	-0.3	32	V	
Gate Off Voltage	V _{GL}	-22	0.3	V	Per piece of LED
Logic Out Voltage	V _{OUT}	-0.3	7.0	V	Per piece of LED
Input Voltage	V _{IN}	-0.3	7.3	V	Per piece of LED
Storage Humidity	H _{STG}	10	90	%RH	1), 2)
Storage Temperature	T _{STG}	-30	80	°C	1), 2)
Operating Ambient Humidity	H _{OP}	10	90	%RH	1), 2)
Operating Ambient Temperature	T _{OP}	-20	60	°C	1), 2)

Note 1) Temp. ≤ 50°C , 90% RH MAX.

Temp. > 40°C , Absolute humidity shall be less than 90% RH at 60°C

Note 2) The diagram below indicates the peripheral environment of the module.

The wet bulb temperature should be kept under 39 °C and there should be no compensation

If the LSI is used above these absolute maximum ratings, it may become permanently damaged.

4. Electrical Specification 1)

4.1 Main Window Display (TFT LCD)

[Ta=25°C]

Properties		Sym.	Min	Typ.	Max	Unit	Note
Power Supply Voltage		Vcc	3.0	3.3	3.6	V	
Supply Voltage		Vdd	3.8	5.0	5.5	V	
Gate On Voltage		Vgh	7	17	25	V	
Gate Off Voltage		Vgl	-20	-11	-5	V	
Operation frequency		Fcpy	60	75	90	Hz	
Back-light Power Consumption		Pbl	-	400	-	mW	3)
Power Consumption	Full	Pfull	-	70	-	mW	3)
Back-light Current		I _B	-	20	-	mA	4)

Note :

- 1) The recommended operating conditions refers to a range in which operation of this product is guaranteed. Should this range is exceeded, the operation cannot be guaranteed even if the values may be within the absolute maximum ratings.
Accordingly, please make sure that the module is used within this range.
And these current values are measured under the condition that all device are stopped, each component is stable and Logic signal is input.
- 2) All the unused input terminals have to be connected to Vdd or Vss. Please select appropriate one which meet the function required by unused terminal.

3) Power Consumption

- (1) VDD=5.1V,
- (2) check pattern = Black pattern. Vcc=3.1V, Frame=60Hz
- (3) Where $I_B=20\text{mA}$, $V_B=PBL/I_B$.
- (4) 6 LEDs serial type.

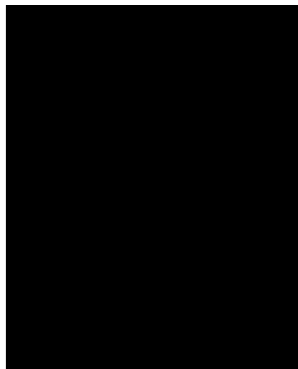

<Check Pattern>

5. Optical Specification

Optical characteristics are determined after the unit has been 'ON' and stable for approximately 30 minutes in a dark environment at 25 °C. The values specified are at an approximate distance 500mm from the LCD surface at a viewing angle of Φ and θ equal to 0 °.

5.1 Main (TFT LCD)

Ta = 25 (Ambient Temperature)

Spec	Parameter	Symbol	Condition	Values			Unit	Notes	
				Min	Typ	Max			
With Backlight LED ON	Contrast Ratio	C/R	$\theta = 0^\circ$	200	400	-		FIG.1	
	Luminance	BP	$\theta = 0^\circ$	160	210	300	cd/m ²	FIG.2	
	Luminance Uniformity	ΔL	$\theta = 0^\circ$	70	80	-	%	FIG.2	
	Response Time	Tr+Tf	$\theta = 0^\circ$	-	25	40	ms	FIG.3	
	Viewing Angle	$\Phi = 180^\circ$	CR>10	$\theta = 0^\circ$	-	45	-	Degree	FIG.4
		$\Phi = 0^\circ$			-	45	-	Degree	
		$\Phi = 90^\circ$			-	35	-	Degree	
		$\Phi = 270^\circ$			-	20	-	Degree	
	CIE Color Coordinate 1931	Wx	$\theta = 0^\circ$	$\theta = 0^\circ$	0.240	0.280	0.320		FIG.1
		Wy			0.250	0.290	0.330		
		Rx	$\theta = 0^\circ$	$\theta = 0^\circ$	0.560	0.600	0.640		
		Ry			0.300	0.340	0.380		
		Gx	$\theta = 0^\circ$	$\theta = 0^\circ$	0.270	0.310	0.350		
		Gy			0.530	0.570	0.610		
Bx		$\theta = 0^\circ$	$\theta = 0^\circ$	0.110	0.150	0.190			
By				0.030	0.070	0.110			
Flicker		$\theta = 0^\circ$	$\theta = 0^\circ$	-	-	12	%	FIG.5	
CrossTalk		$\theta = 0^\circ$	$\theta = 0^\circ$	-	-	30	%	FIG.6	
Color Gamut		$\theta = 0^\circ$	$\theta = 0^\circ$	50	58	-	%		
Color Temperature	K	$\theta = 0^\circ$	$\theta = 0^\circ$	8,000	10,000	12,000	K	White	

◆ **Measurement System**

Notes :

1. Contrast Ratio(CR) is defined mathematically as :

$$\text{Contrast Ratio} = \frac{\text{Surface Luminance with all white pixels}}{\text{Surface Luminance with all black pixels}}$$

2. Surface luminance is the center point across the LCD surface 500mm from the surface with all pixels displaying white. For more information see FIG 1.

3. Response time is the time required for the display to transition from white to black (Rising Time, Tr) and from black to white (Falling Time, Tf). For additional information see FIG 3.

4. Viewing angle is the angle at which the contrast ratio is greater than 10. The angles are determined for the horizontal or x axis and the vertical or y axis with respect to the z axis which is normal to the LCD surface. For more information see FIG 4.

FIG. 1. Optical Characteristic Measurement Equipment and Method

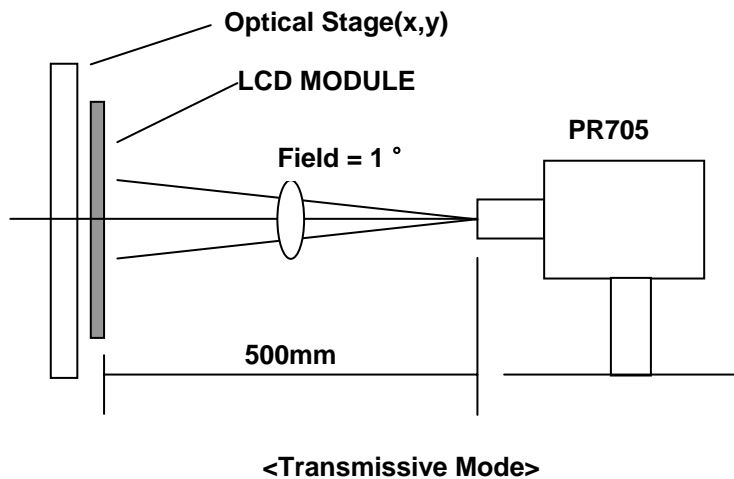

- Measurement System (Test Procedure) With backlight turned on
- Measuring Instrument: PR705 made by PHOTO RESEARCH
- Measuring Field : 1°
- Environment: Inside a darkroom

FIG. 2. Measurement Points for Luminance

► Luminance Uniformity

Using FIG.1 Measurement System with the backlight turned on, the luminance uniformity should be obtained from the next expression, when white raster (white : gradation level L63) is displayed: (* LED Current = 20mA)

$$\text{Luminance Uniformity} = L_{\min} / L_{\max} \times 100 (\%)$$

, L_{\min} = Minimum luminance point
 L_{\max} = Maximum luminance point

► Luminance

Use FIG.1(Test Procedure) under Measurement System with the backlight turned on to measure the luminance when white raster (white: Gradation level L63) is displayed.

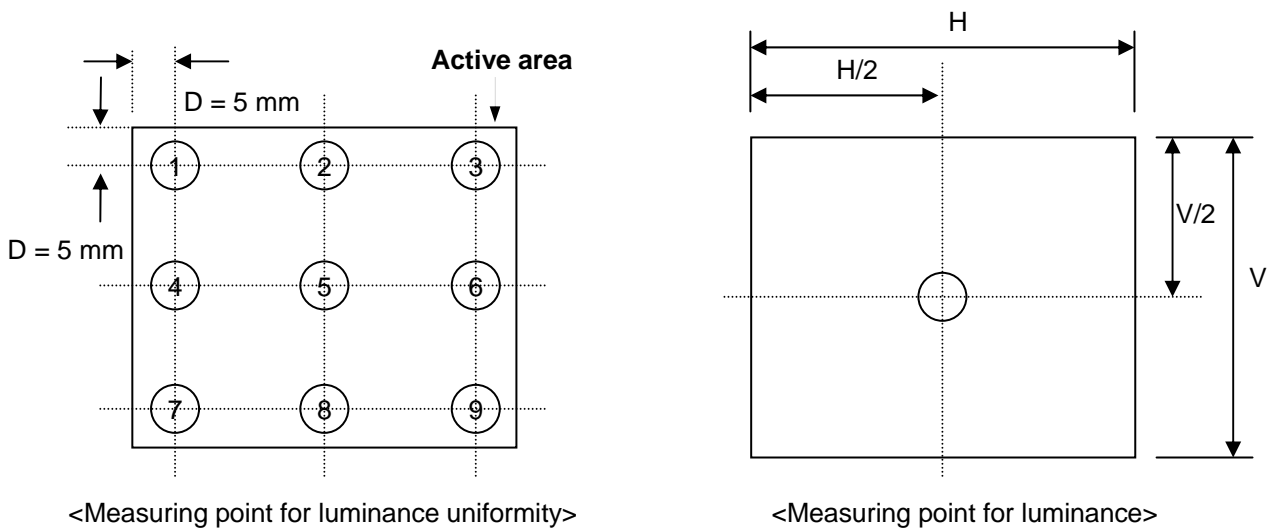

FIG. 3. The definition of Response Time

The response time is defined as the following figure and shall be measured by switching the input signal for “black” and “white”.

Response Time = Rising Time (T_r) + Falling Time (T_f)
 , Rising Time(T_r) : Full White 90% → Full White 10% Transmittance.
 Falling Time(T_f) : Full White 10% → Full White 90% Transmittance.

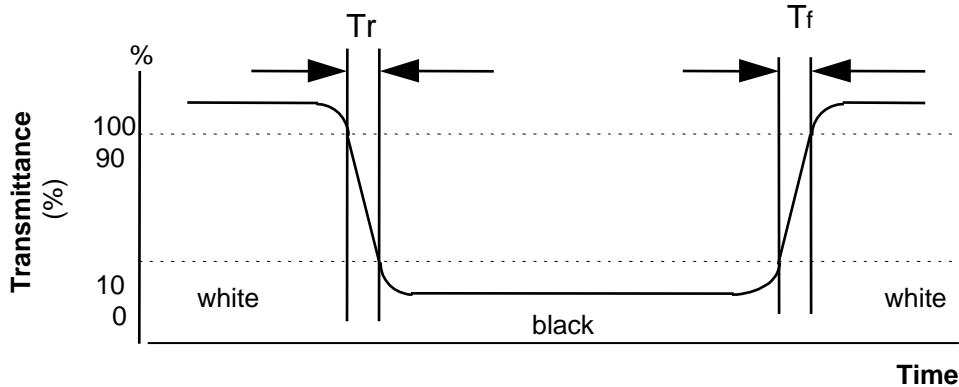

FIG. 4. The definition of Viewing Angle

Use Fig. 1 (Test Procedure) under Measurement System to measure the contrast from the measuring direction specified by the conditions as the following figure.

The definition of viewing angle range is that the contrast ratio is higher than CR 10. (CR > 10)

<dimension of viewing angle range>

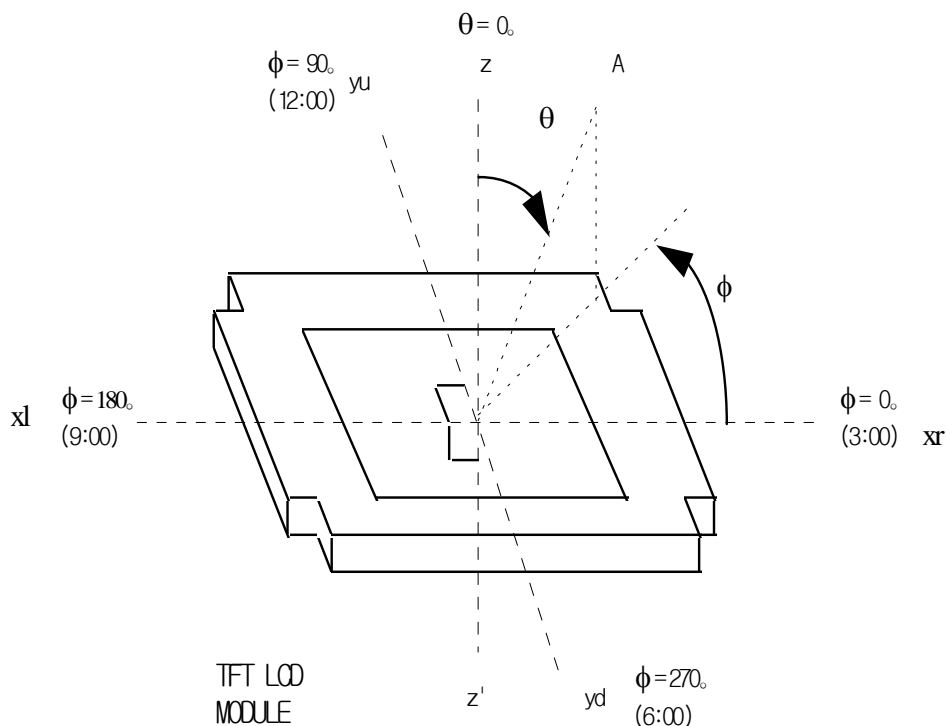
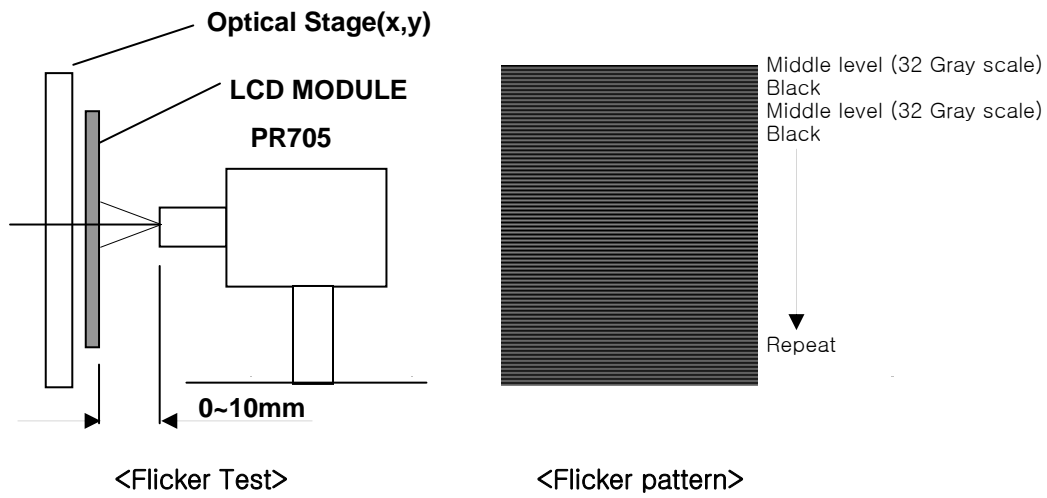

Fig. 5. Measuring Method for Flicker Level



- Measurement System (Test Procedure) With backlight turned on
- Measuring Instrument : PR705 made by PHOTO RESEARCH
- Measuring Field : 1°
- Environment: Inside a darkroom
- Display a flicker pattern (see below) and measure flicker level (%) with flicker checker.
- Distance from the flicker pattern to the checker is 0~10mm.

Fig. 6. Measuring Method for Crosstalk

$$\text{Crosstalk(\%)} = \frac{|\text{Luminance(A-pattern)} - \text{Luminance(B-pattern)}|}{\text{Luminance(A-pattern)}} \times 100$$

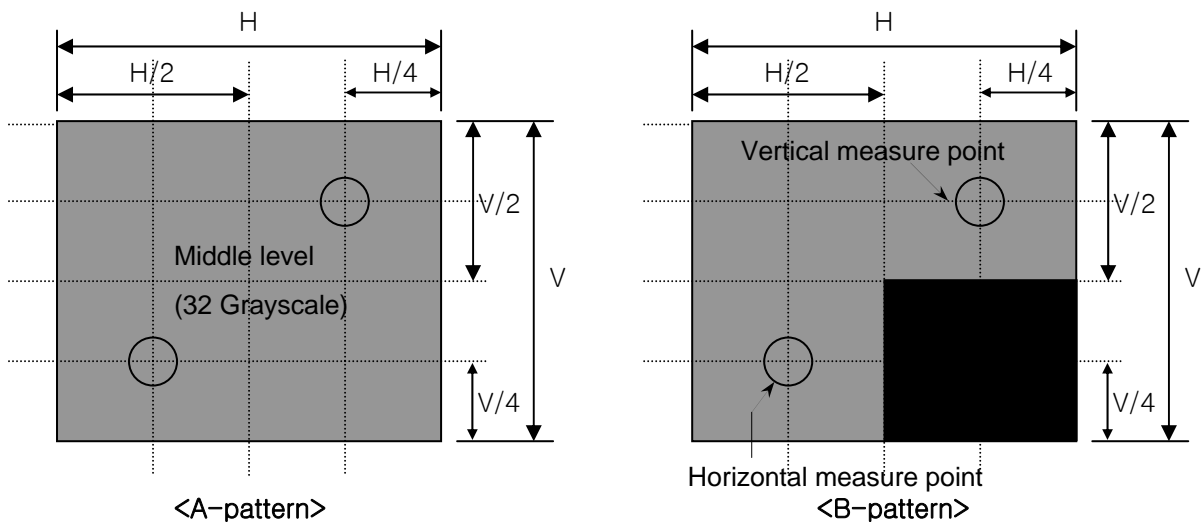

Crosstalk means irregularity of luminance in the background when window pattern (white against black background) is displayed.

6. Block Diagram

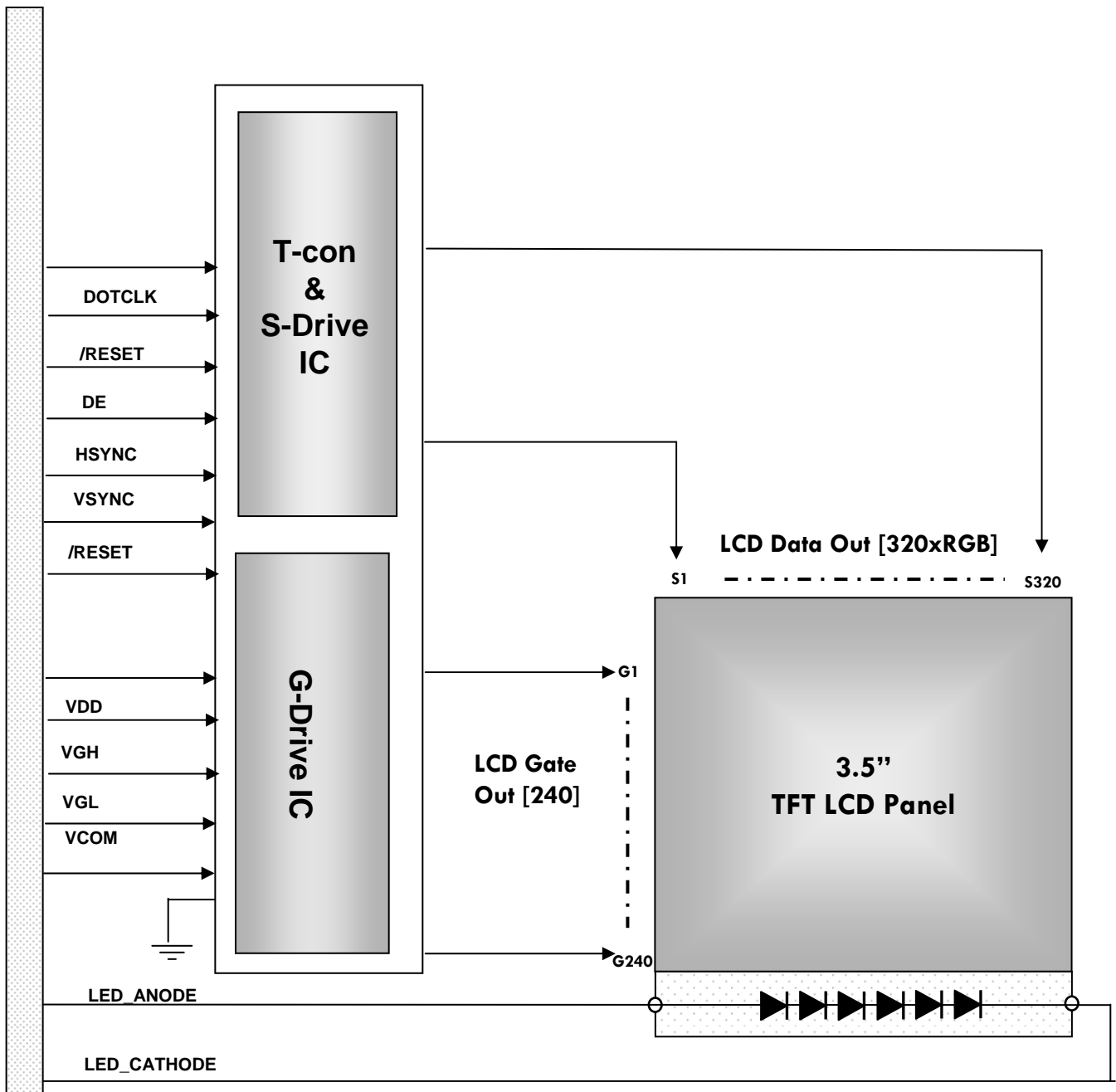

7. Pin Description

7.1. Input signal and power : pin description (Kyocera 04-6240-054-005-800)

NO	PORT	FUNCTION	I/O	NO	PORT	FUNCTION	I/O
1,2	LED_CATHODE	LDE_CATHODE	PI	27	D17-G7	Green Data 7	I
3,4	LED_ANODE	LED_ANODE	P	28	D0-R0	Red Data 0	I
5,6	C1,2	Stable Cap connection		29	D1-R1	Red Data 1	I
7	NC	No Connector		30	D2-R2	Red Data 2	I
8	/RESET	Reset	I	31	D3-R3	Red Data 3	I
9	SPI_CS	SPI chip selection	I	32	D4-R4	Red Data 4	I
10	SPI_Clock	SPI Clock	I	33	D5-R5	Red Data 5	I
11	SPI_data	SPI Data	I/O	34	D6-R6	Red Data 6	I
12	D20-B0	Blue Data 0	I	35	D7-R7	Red Data 7	I
13	D21-B1	Blue Data 1	I	36	HSYNC	Horizontal Sync. Signal	I
14	D22-B2	Blue Data 2	I	37	VSYNC	Vertical Sync. Signal	I
15	D23-B3	Blue Data 3	I	38	DOTCLK	Data Clock	I
16	D24-B4	Blue Data 4	I	39,40	VDD	Analog Power	P
17	D25-B5	Blue Data 5	I	41,42	VCC	Logic Power	P
18	D26-B6	Blue Data 6	I	43	C3	Stable Cap connection	
19	D27-B7	Blue Data 7	I	44,45	VGL	Vgoff Voltage	P
20	D10-G0	Green Data 0	I	46	C4	Stable Cap connection	
21	D11-G1	Green Data 1	I	47	VGH	Vgon Voltage	P
22	D12-G2	Green Data 2	I	48,49	C5,6	Stable Cap connection	
23	D13-G3	Green Data 3	I	50,51	NC	No Connector	P
24	D14-G4	Green Data 4	I	52	DE	Input data enable	I
25	D15-G5	Green Data 5	I	53,54	GND	Ground	P
26	D16-G6	Green Data 6	I				

7.2. Relation Between Input Signal and Color

COLOR	DISPLAY	DATA SIGNAL																				GARY SCALE LEVEL				
		R7	R6	R5	R4	R3	R2	R1	R0	R7	R6	R5	R4	R3	R2	R1	R0	R7	R6	R5	R4		R3	R2	R1	R0
BASIC COLOR	BLACK	0	0	0	0	0	0	0	0	0	0	0	0	0	0	0	0	0	0	0	0	0	0	0	-	
	BLUE	0	0	0	0	0	0	0	0	0	0	0	0	0	0	0	0	1	1	1	1	1	1	1	1	-
	GREEN	0	0	0	0	0	0	0	0	1	1	1	1	1	1	1	1	0	0	0	0	0	0	0	0	-
	CYAN	0	0	0	0	0	0	0	1	1	1	1	1	1	1	1	1	1	1	1	1	1	1	1	1	-
	RED	1	1	1	1	1	1	1	1	0	0	0	0	0	0	0	0	0	0	0	1	0	0	0	0	-
	MAGENTA	1	1	1	1	1	1	1	1	0	0	0	0	0	0	0	0	1	1	1	1	1	1	1	1	-
	YELLOW	1	1	1	1	1	1	1	1	1	1	1	1	1	1	1	1	0	0	0	0	0	0	0	0	-
WHITE	1	1	1	1	1	1	1	1	1	1	1	1	1	1	1	1	1	1	1	1	1	1	1	1	-	
GARY SCALE OF RED	BLACK	0	0	0	0	0	0	0	0	0	0	0	0	0	0	0	0	0	0	0	0	0	0	0	R0	
	DARK	0	0	0	0	0	0	1	0	0	0	0	0	0	0	0	0	0	0	0	0	0	0	0	R1	
	.	0	0	0	0	0	0	1	0	0	0	0	0	0	0	0	0	0	0	0	0	0	0	0	R2	
	.	:	:	:	:	:	:	:	:	:	:	:	:	:	:	:	:	:	:	:	:	:	:	:	R3~R252	
	.	:	:	:	:	:	:	:	:	:	:	:	:	:	:	:	:	:	:	:	:	:	:	:	R253	
	LIGHT	1	1	1	1	1	0	1	0	0	0	0	0	0	0	0	0	0	0	0	0	0	0	0	R254	
	RED	1	1	1	1	1	1	1	0	0	0	0	0	0	0	0	0	0	0	0	0	0	0	0	R255	
GARY SCALE OF GREEN	BLACK	0	0	0	0	0	0	0	0	0	0	0	0	0	0	0	0	0	0	0	0	0	0	0	G0	
	DARK	0	0	0	0	0	0	0	0	0	0	0	0	0	0	0	1	0	0	0	0	0	0	0	G1	
	.	0	0	0	0	0	0	0	0	0	0	0	0	0	0	1	0	0	0	0	0	0	0	0	G2	
	.	:	:	:	:	:	:	:	:	:	:	:	:	:	:	:	:	:	:	:	:	:	:	:	G3~G252	
	.	:	:	:	:	:	:	:	:	:	:	:	:	:	:	:	:	:	:	:	:	:	:	:	G253	
	LIGHT	0	0	0	0	0	0	0	1	1	1	1	1	1	1	0	0	0	0	0	0	0	0	0	G254	
	GREEN	0	0	0	0	0	0	0	1	1	1	1	1	1	1	1	0	0	0	0	0	0	0	0	G255	
GARY SCALE OF BLUE	BLACK	0	0	0	0	0	0	0	0	0	0	0	0	0	0	0	0	0	0	0	0	0	0	0	B0	
	DARK	0	0	0	0	0	0	0	0	0	0	0	0	0	0	0	0	0	0	0	0	0	0	1	B1	
	.	0	0	0	0	0	0	0	0	0	0	0	0	0	0	0	0	0	0	0	0	0	1	0	B2	
	.	:	:	:	:	:	:	:	:	:	:	:	:	:	:	:	:	:	:	:	:	:	:	:	B3~B252	
	.	:	:	:	:	:	:	:	:	:	:	:	:	:	:	:	:	:	:	:	:	:	:	:	B253	
	LIGHT	0	0	0	0	0	0	0	0	0	0	0	0	0	0	0	1	1	1	1	1	1	1	0	B254	
	BLUE	0	0	0	0	0	0	0	0	0	0	0	0	0	0	0	1	1	1	1	1	1	1	1	B255	

Note) Gray definition

Rn : RED Gray, Gn : GREEN Gray, Bn : BLUE Gray (n = Gray Level)

Input Signal : 0 = Low level voltage, 1 = High level voltage

8. Register Values

8.1 Command Description

8.1.1 SPI Resister Description

- Register R0:

Bit	D7	D6	D5	D4	D3	D2	D1	D0
Name	reserved	STHD1	STHD0	STHP4	STHP3	STHP2	STHP1	STHP0
Default	0	0	0	0	0	0	0	0

STHD [1:0]: adjust start pulse position by dot.

STHD1	STHD0	STH position adjust by dot
1	1	-1
1	0	-2
0	0	0
0	1	+1

STHP [4:0]: adjust start pulse position by pixel

STHP4	STHP3	STHP2	STHP1	STHP0	STH position adjust by pixel
1	1	1	1	1	-1
1	1	1	1	0	-2
1	1	1	0	1	-3
1	1	1	0	0	-4
1	1	0	1	1	-5
1	1	0	1	0	-6
1	1	0	0	1	-7
1	1	0	0	0	-8
1	0	1	1	1	-9
1	0	1	1	0	-10
1	0	1	0	1	-11
1	0	1	0	0	-12
1	0	0	1	1	-13
1	0	0	1	0	-14
1	0	0	0	1	-15
1	0	0	0	0	-16
0	0	0	0	0	0
0	0	0	0	1	+1
0	0	0	1	0	+2
0	0	0	1	1	+3
0	0	1	0	0	+4
0	0	1	0	1	+5
0	0	1	1	0	+6
0	0	1	1	1	+7
0	1	0	0	0	+8
0	1	0	0	1	+9
0	1	0	1	0	+10
0	1	0	1	1	+11
0	1	1	0	0	+12
0	1	1	0	1	+13
0	1	1	1	0	+14
0	1	1	1	1	+15

● Register R1:

Bit	D7	D6	D5	D4	D3	D2	D1	D0
Name	STVP3	STVP2	STVP1	STVP0	reserved	reserved	reserved	reserved
Default	0	0	0	0	0	0	0	1

STVP [3:0]: adjust first line position by line

STVP3	STVP2	STVP1	STVP0	STV position adjust by line
1	1	1	1	-1
1	1	1	0	-2
1	1	0	1	-3
1	1	0	0	-4
1	0	1	1	-5
1	0	1	0	-6
1	0	0	1	-7
1	0	0	0	-8
0	0	0	0	0
0	0	0	1	+1
0	0	1	0	+2
0	0	1	1	+3
0	1	0	0	+4
0	1	0	1	+5
0	1	1	0	+6
0	1	1	1	+7

● Register R2:

Bit	D7	D6	D5	D4	D3	D2	D1	D0
Name	reserved	reserved	reserved	reserved	VS POL	HS POL	NPC IN	NPC SET
Default	0	0	1	1	0	0	1	0

VS_POL: VS polarity setting.

VS_POL=L, negative polarity.

VS_POL=H, positive polarity.

HS_POL: HS polarity setting.

HS_POL=L, negative polarity.

HS_POL=H, positive polarity.

NPC_IN: define the NTSC/PAL mode by SPI.

NPC_IN=L, PAL.

NPC_IN=H, NTSC.

NPC_SET: set the NTSC/PAL auto detection or define by NPC_IN.

NPC_SET=L, auto detection.

NPC_SET=H, define by NPC_IN.

8. 2 Power on/off sequence

To prevent the device damage from latch up, the power on/off sequence shown below must be followed

Power ON : VCC → VDD → V1 ~V8
 Power OFF : V1 ~ V8 → VDD → VCC

8. 3 Digital RGB Timing Waveform

8.3.1 HIS and IVS Timing

- Odd field

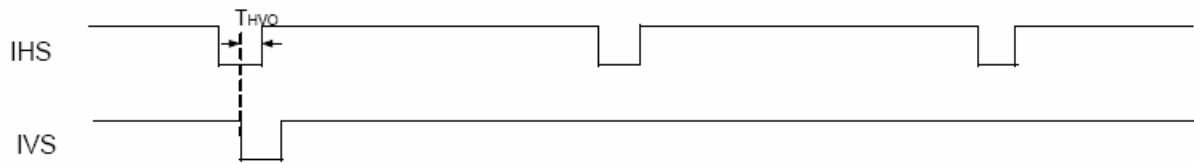

- Even field

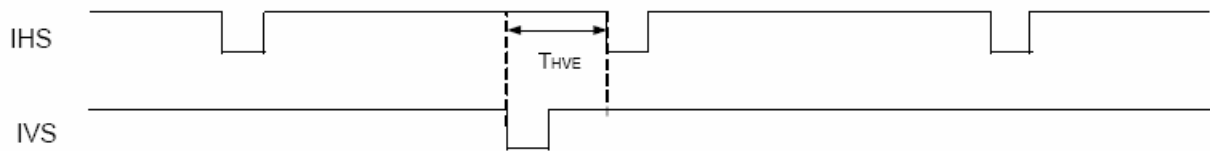

8.3.2 HIS and Horizontal control timing waveform

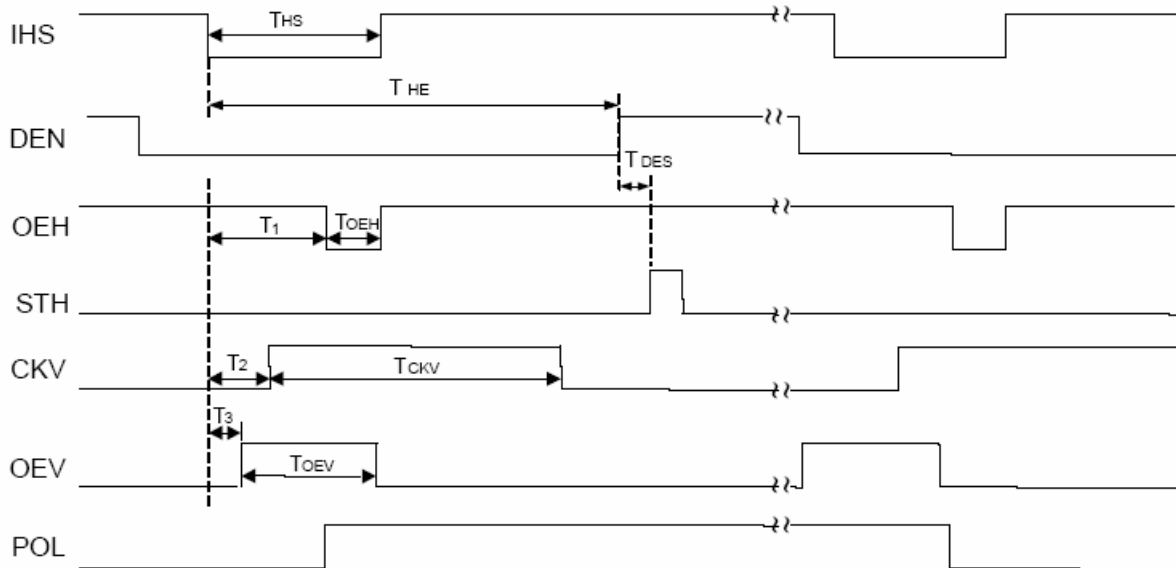

Note : (1) HIS=Hsync, IVS=Vsync

8.3.3 HIS and Vertical shift clock timing waveform

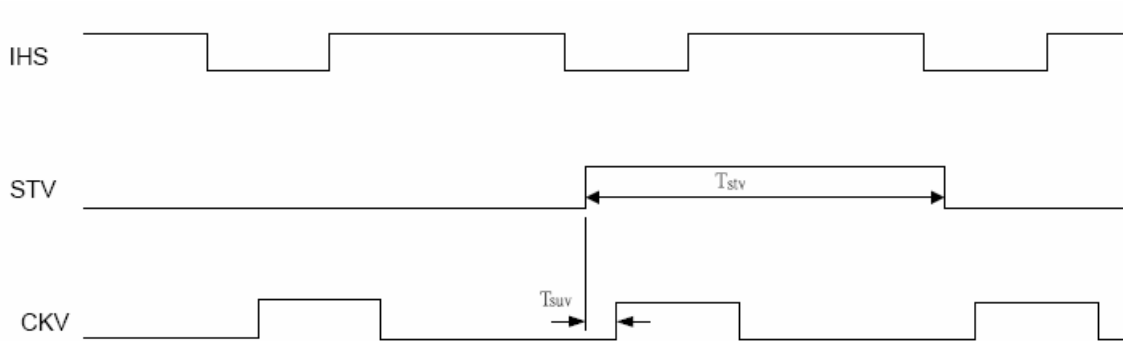

8.3.4 HIS and Vertical control timing waveform

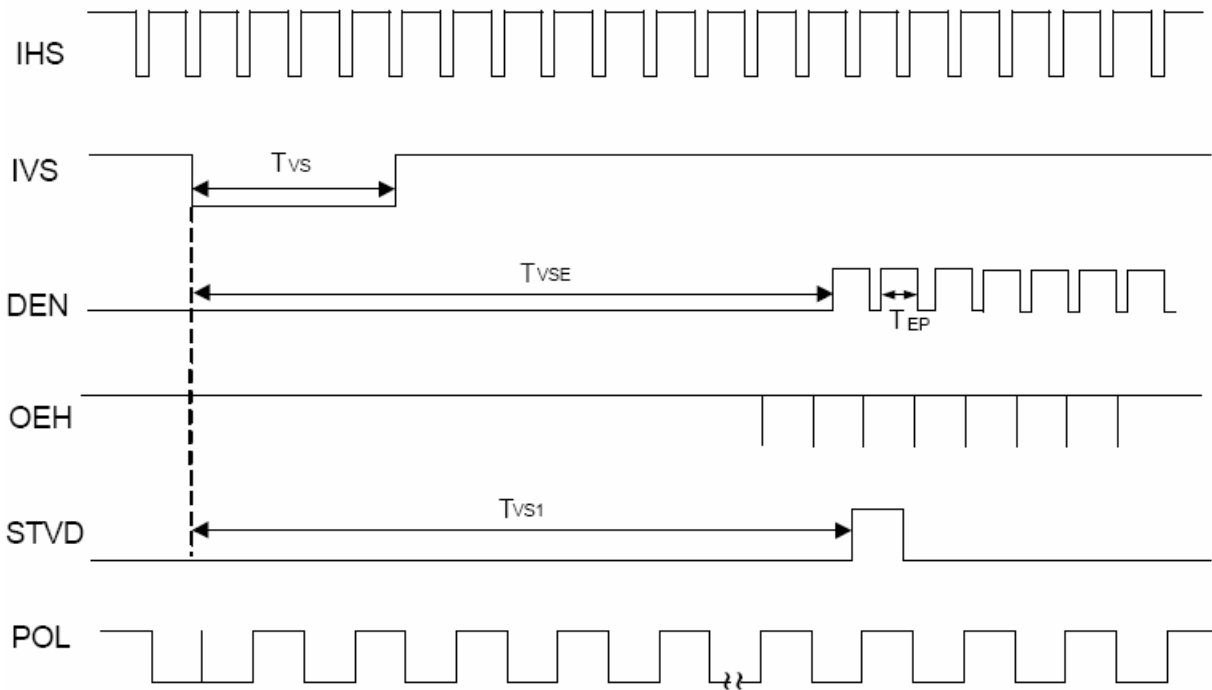

8.4 Source Driver Timing Chart

8.4.1 Clock and Start Pulse timing waveform

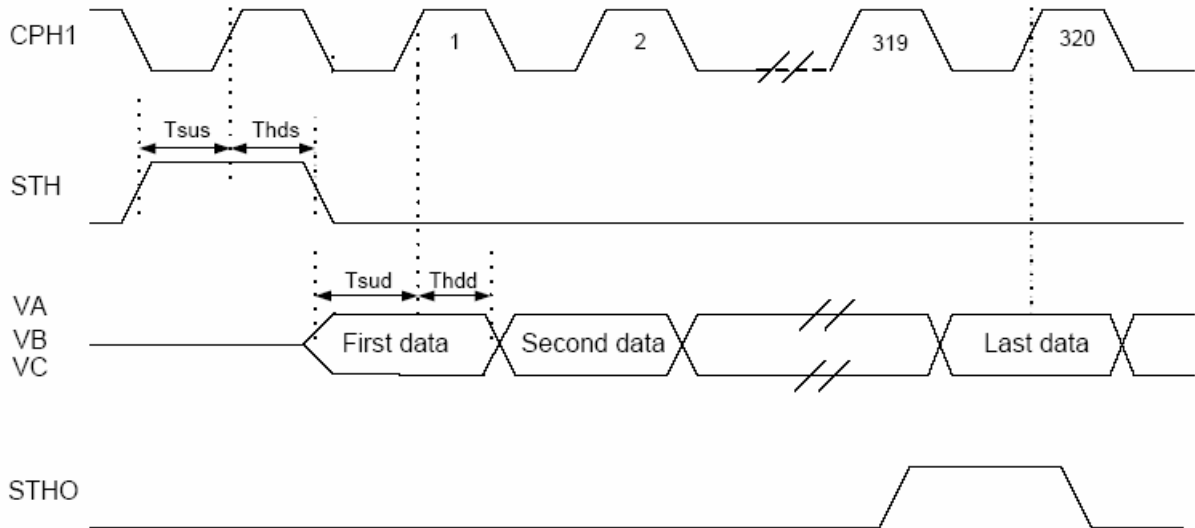

8.4.2 Control Signal and RGB Data timing waveform

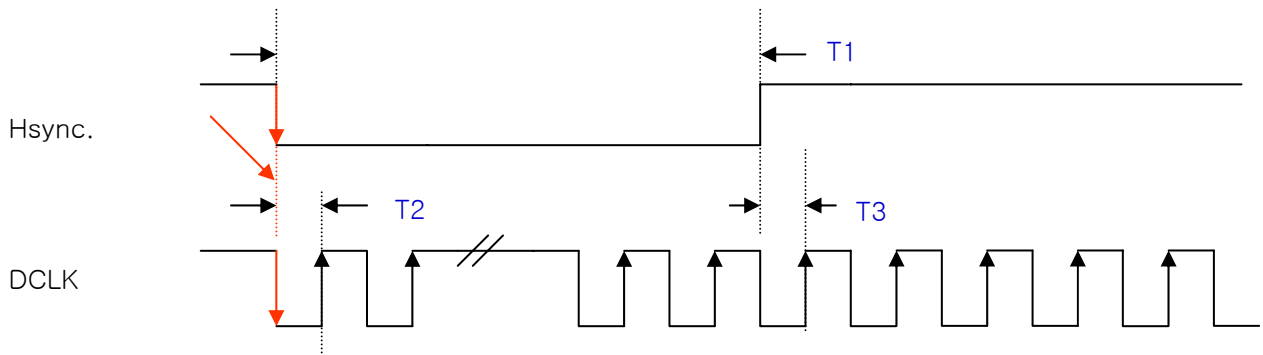

T1 : Min. 5 DCLK ~ Max. 30 DCLK

T2 : Set-up Time Min. 12ns

T3 : Hold Time Min. 12ns

** Must be synchronized between Hsync. Falling edge and Dot Clock falling edge.

9. AC Characteristics

9.1 Input Signal characteristics

Digital Parallel RGB Interface (960 x 240 resolution)

PARAMETER	Symbol	Min.	Typ.	Max.	Unit
CLK period	T_{OSC}	-	156	-	ns
Data setup time	T_{SU}	12	-	-	ns
Data hold time	T_{HD}	12	-	-	ns
IHS period	T_H	-	408	-	T_{OSC}
IHS pulse width	T_{HS}	5	30	-	T_{OSC}
IHS rising time	T_{Cr}	-	-	700	ns
IHS falling time	T_{Cf}	-	-	300	ns
IVS pulse width	T_{VS}	1	3	5	T_H
IVS rising time	T_{Vr}	-	-	700	ns
IVS falling time	T_{Vf}	-	-	1.5	μs
IVS falling to IHS rising time for odd field	T_{HVO}	1	-	-	T_{OSC}
IVS falling to IHS falling time for even field	T_{HVE}	1	-	-	T_{OSC}
IVS-DEN time	NTSC	T_{VSE}	-	18	T_H
	PAL	T_{VSE}	-	26	T_H
IHS-DEN time	T_{HE}	36	68	88	T_{OSC}
DEN pulse width	T_{EP}	-	320	-	T_{OSC}
DEN-STH time	T_{DES}	-	1	-	T_{OSC}
IVS period	NTSC	-	262.5	-	T_H
	PAL	-	312.5	-	T_H

Note:

(1)When SYNC mode is used, 1st data start from 68th CLK after IHS falling.

9.2 Hardware reset timing

PARAMETER	Symbol	Min.	Typ.	Max.	Unit.
RESETB low pulse width	T_{RSB}	10	-	-	μs

9.3 Output signal characteristics for digital input signal

PARAMETER	Symbol	Min.	Typ.	Max.	Unit.
Rising time	T_r	-	-	10	ns
Falling time	T_f	-	-	10	ns
Internal STH setup time	T_{SUS}	12	-	-	ns
Internal STH hold time	T_{HDS}	12	-	-	ns
Internal data setup time	T_{SID}	60	-	-	ns
Internal data hold time	T_{HDD}	40	-	-	ns
OEH pulse width	T_{OEH}	-	1248	-	ns
OEV pulse width	T_{OEV}	-	4992	-	ns
CKV pulse width	T_{CKV}	-	3744	-	ns
IHS-OEH time	T_1	-	4368	-	ns
IHS-CKV time	T_2	-	2496	-	ns
IHS-OEV time	T_3	-	624	-	ns
STV setup time	T_{SUV}	-	1872	-	ns
STV pulse width	T_{STV}	-	1	-	T_H
IVS-STV time	NTSC	T_{VS1}	-	19	T_H
	PAL	T_{VS1}	-	27	T_H
OEH-STV time	T_{OES}	-	2	-	T_H
Output settling time	T_{ST}	-	12	20	μs

10. SPI Timing Characteristics

PARAMETER	Symbol	Min.	Typ.	Max.	Unit.
SPCK period	T_{CK}	60	-	-	ns
SPCK high width	T_{CKH}	30	-	-	ns
SPCK low width	T_{CKL}	30	-	-	ns
Data setup time	T_{SU1}	12	-	-	ns
Data hold time	T_{HD1}	12	-	-	ns
SPENA to SPCK setup time	T_{CS}	20	-	-	ns
SPENA to SPDA hold time	T_{CE}	20	-	-	ns
SPENA high pulse width	T_{CD}	50	-	-	ns
SPDA output latency	T_{CR}	-	1/2	-	T_{CK}

● SPI read timing

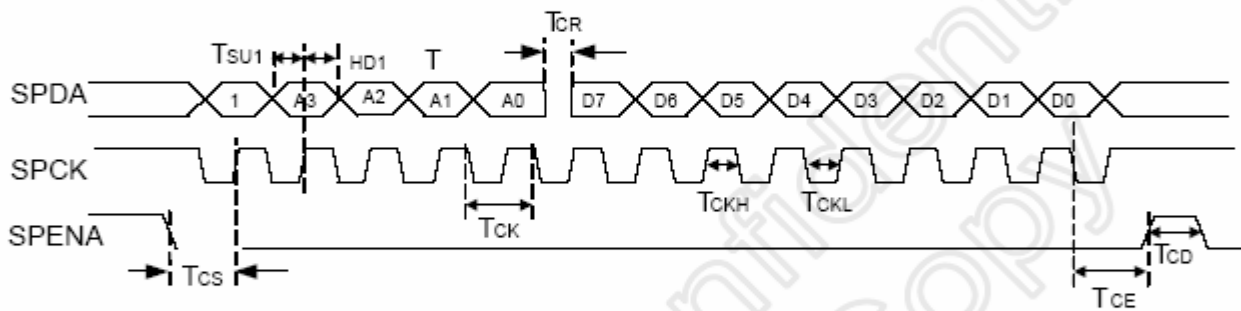
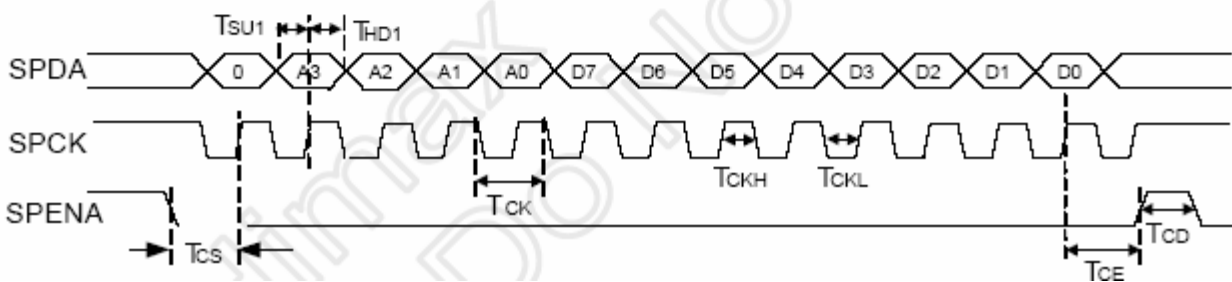

Figure 9. 2 SPI Read Timing

● SPI write timing



11. Reliability and Inspection Standard

11.1 Reliability Testing Condition

No	Test Item	Test Conditions	Remark
1	High Temperature Operation	60 °C , 96 Hr	
2	Low Temperature Operation	-20 °C , 96 Hr	
3	High Temperature and High Humidity Operation	+50 °C , 90~95%RH, 96Hr	
4	High Temperature and High Humidity Storage	+60 °C , 90~95%RH, 96Hr	
5	Low Temperature Storage	-30 °C , 96 Hr	
6	Thermal Shock	- 30 ⇔ 80 °C(0.5hr) 50CYC	
7	Vibration Test	1~22Hz(05s) → 22Hz(15s) → 22~48Hz(05s) → 48Hz(15s) → 48~55Hz(05s) → 55Hz(15s), 2Hr	
8	Drop Test	50cm / 3Corner / 6Face, 1cycle	Packaged in a box
9	Electrostatic withstanding voltage	Air : 0Ohm, 200pF ± 200V	
		Contact : 0Ohm 200pF ± 200V	

11.2 Fault Judgment Criteria

After Completing the reliability tests, leave the samples under the room temperature(25 °C, 40%RH) for 2 hours and check for the following inspection items.

- (1) No clearly visible defects or deterioration of display quality allowed.
- (2) Contrast ratio should be at least 50% of initial value.
- (3) No function-related abnormalities.
- (4) Current consumption must not exceed 2 times of initial value.
- (5) R, G and B color area must be at least 70% of initial value.

11.3 Inspection Standard

11.3.1 Inspection Standard for Main LCD

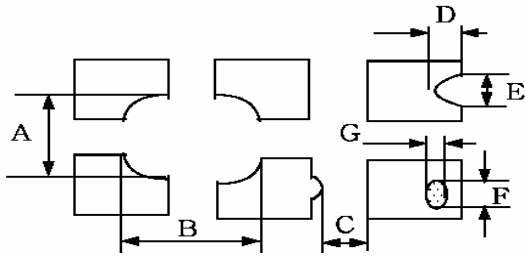
No	Item	Criterion for Defects	Defect type										
1	Non Lighting	Nothing	Major										
2	Irregular Operation	Nothing	Major										
3	Short	Nothing	Major										
4	Open	Nothing	Major										
5	Black/White Spot	<table border="1"> <thead> <tr> <th>Size Φ (mm)</th> <th>Acceptable number</th> </tr> </thead> <tbody> <tr> <td>$\Phi \leq 0.10$</td> <td>Ignore (note)</td> </tr> <tr> <td>$0.10 < \Phi \leq 0.20$</td> <td>2</td> </tr> <tr> <td>$0.20 < \Phi \leq 0.30$</td> <td>1</td> </tr> <tr> <td>$0.20 < \Phi$</td> <td>0</td> </tr> </tbody> </table>	Size Φ (mm)	Acceptable number	$\Phi \leq 0.10$	Ignore (note)	$0.10 < \Phi \leq 0.20$	2	$0.20 < \Phi \leq 0.30$	1	$0.20 < \Phi$	0	Minor
Size Φ (mm)	Acceptable number												
$\Phi \leq 0.10$	Ignore (note)												
$0.10 < \Phi \leq 0.20$	2												
$0.20 < \Phi \leq 0.30$	1												
$0.20 < \Phi$	0												
6	Black/White Line	<table border="1"> <thead> <tr> <th>Length (mm)</th> <th>Width (mm)</th> <th>Acceptable number</th> </tr> </thead> <tbody> <tr> <td>$1.0 > L$</td> <td>$0.03 \leq W$</td> <td>Ignore</td> </tr> <tr> <td>$1.0 < L \leq 3.0$</td> <td>$0.03 < W \leq 0.08$</td> <td>3</td> </tr> </tbody> </table>	Length (mm)	Width (mm)	Acceptable number	$1.0 > L$	$0.03 \leq W$	Ignore	$1.0 < L \leq 3.0$	$0.03 < W \leq 0.08$	3	Minor	
Length (mm)	Width (mm)	Acceptable number											
$1.0 > L$	$0.03 \leq W$	Ignore											
$1.0 < L \leq 3.0$	$0.03 < W \leq 0.08$	3											
7	Back Light	<p>① No light is rejectable</p> <p>② Flickering and abnormal lighting are rejectable</p> <p>※ In case of the model with back light (E/L, LED)</p>	Major										
8	Display Pattern	 <p>[Unit : mm]</p> <table border="1"> <tbody> <tr> <td>$\frac{A+B}{2} \leq 0.30$</td> <td>$0 < C$</td> <td>$\frac{D+E}{2} \leq 0.25$</td> <td>$\frac{F+G}{2} \leq 0.25$</td> </tr> </tbody> </table> <p>Note : 1) Acceptable up to 3 damages 2) NG if there're two or more pinholes per dot</p>	$\frac{A+B}{2} \leq 0.30$	$0 < C$	$\frac{D+E}{2} \leq 0.25$	$\frac{F+G}{2} \leq 0.25$	Minor						
$\frac{A+B}{2} \leq 0.30$	$0 < C$	$\frac{D+E}{2} \leq 0.25$	$\frac{F+G}{2} \leq 0.25$										

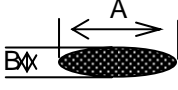
No	Item	Criterion for Defects	Defect type									
9	Scratch on Polarizer 	<table border="1"> <thead> <tr> <th>Width (mm)</th> <th>Length (mm)</th> <th>Acceptable number</th> </tr> </thead> <tbody> <tr> <td>$W \leq 0.03$</td> <td>Ignore</td> <td>Ignore</td> </tr> <tr> <td>$0.03 < W \leq 0.05$</td> <td>$3.0 < L \leq 5.0$ Note (1)</td> <td>3</td> </tr> </tbody> </table>	Width (mm)	Length (mm)	Acceptable number	$W \leq 0.03$	Ignore	Ignore	$0.03 < W \leq 0.05$	$3.0 < L \leq 5.0$ Note (1)	3	Minor
		Width (mm)	Length (mm)	Acceptable number								
$W \leq 0.03$	Ignore	Ignore										
$0.03 < W \leq 0.05$	$3.0 < L \leq 5.0$ Note (1)	3										
<table border="1"> <thead> <tr> <th>Size Φ (mm)</th> <th>Acceptable number</th> </tr> </thead> <tbody> <tr> <td>$\Phi \leq 0.10$</td> <td>Ignore</td> </tr> <tr> <td>$0.10 < \Phi \leq 0.20$</td> <td>2</td> </tr> <tr> <td>$0.20 < \Phi \leq 0.30$</td> <td>1</td> </tr> </tbody> </table>	Size Φ (mm)	Acceptable number	$\Phi \leq 0.10$	Ignore	$0.10 < \Phi \leq 0.20$	2	$0.20 < \Phi \leq 0.30$	1	Minor			
Size Φ (mm)	Acceptable number											
$\Phi \leq 0.10$	Ignore											
$0.10 < \Phi \leq 0.20$	2											
$0.20 < \Phi \leq 0.30$	1											

※Remarks

- Use the inspection tool like a loupe or microscope if there is no conviction of pass/fail criteria.
- Translucent edge is ignored in measuring the diameter of spot.

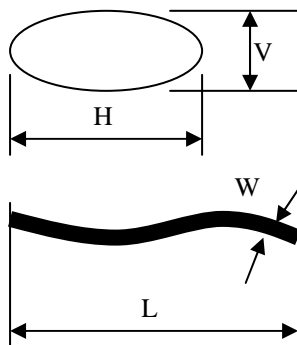

▪ Diameter of Spots and Bubbles

$$\Phi = [\text{Vertical}(V) + \text{Horizontal}(H)] / 2$$

▪ Length and Width of Lines and Scratches

No	Test Item	Criterion for Defects		Remark
11	Bright Dot	Dot Type	Quantity (ea)	
		Random (Red , Blue, Green)	1	
		2 or more adjacent dot defects	0	
12	Dark Dot	Dark dot	3	
		2adjacent dot defects	1	
		3 or more adjacent dot defects	0	
13	Total Dot Defects	Maximum allowable number of dot defect	4	
	Defect Distance	Minimum distance between defects	Don't care	
14	Parts Mounting	① Failure to mount parts ② Parts not in the specifications are mounted ③ Polarity, for example, is reversed		Major Major Major
15	Parts Alignment	① LSI, IC Lead width is more than 50% beyond pad outline. ② Chip component is off center and more tan 50% of the leads is off the pad outline.		Minor Minor
16	Conductive Foreign matter	① On open space(GND, manual solder) solder ball is allowed up to $\Phi 0.1\text{mm}$ (1EA). ② In case of sheild space is allowed up to $\Phi 0.2\text{mm}$ (1EA)		Minor
17	Faculty PWB correction	① Due to PWB copper foil pattern burnout, the pattern is connected, using a jumper wire for repair ; 2 or more places are corrected per PWB		Minor
		② Short circuited part is cut, and no resist coating has been performed.		Minor

12-1. Outline Dimension

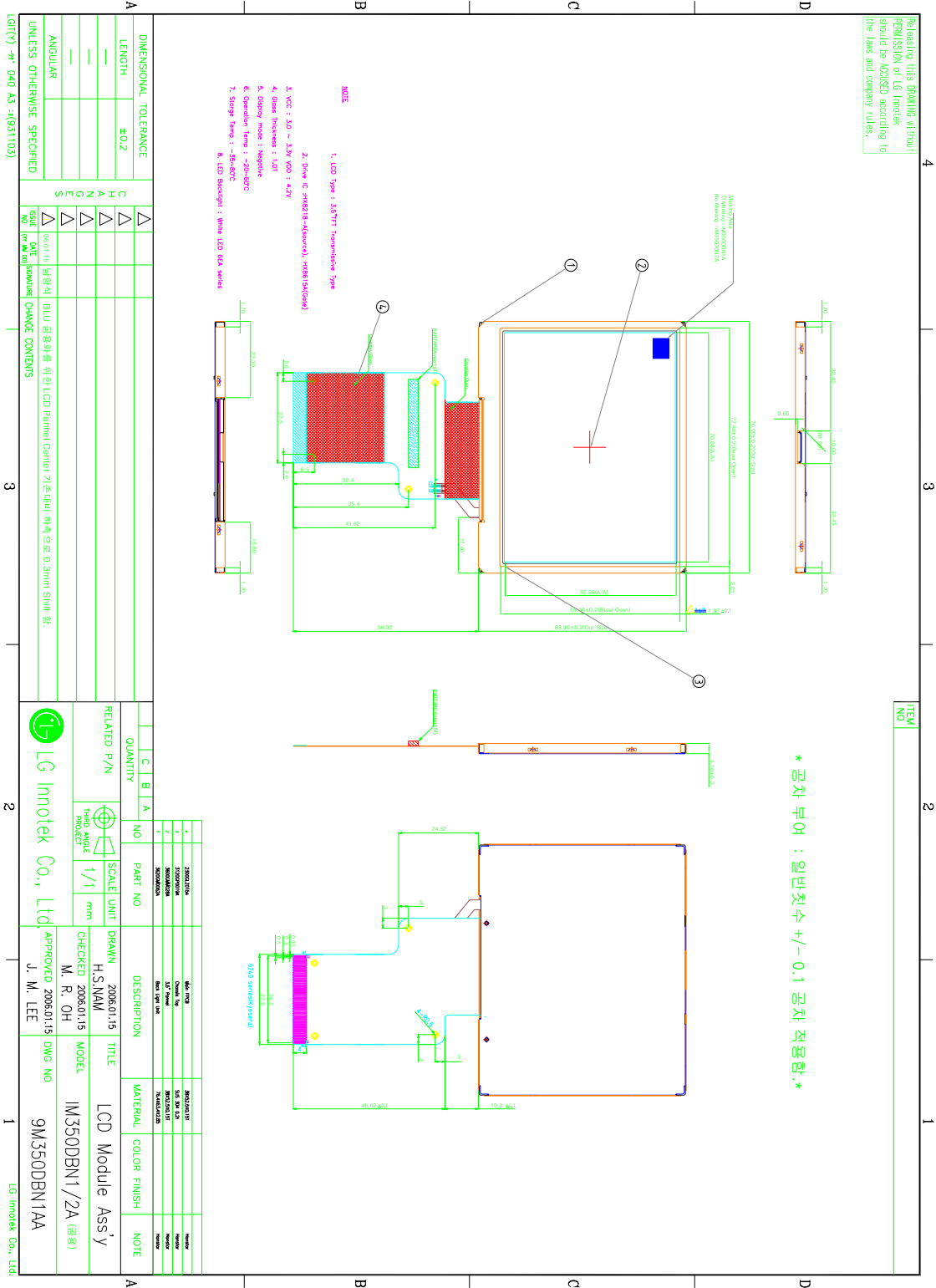

12-2. Circuit Diagram

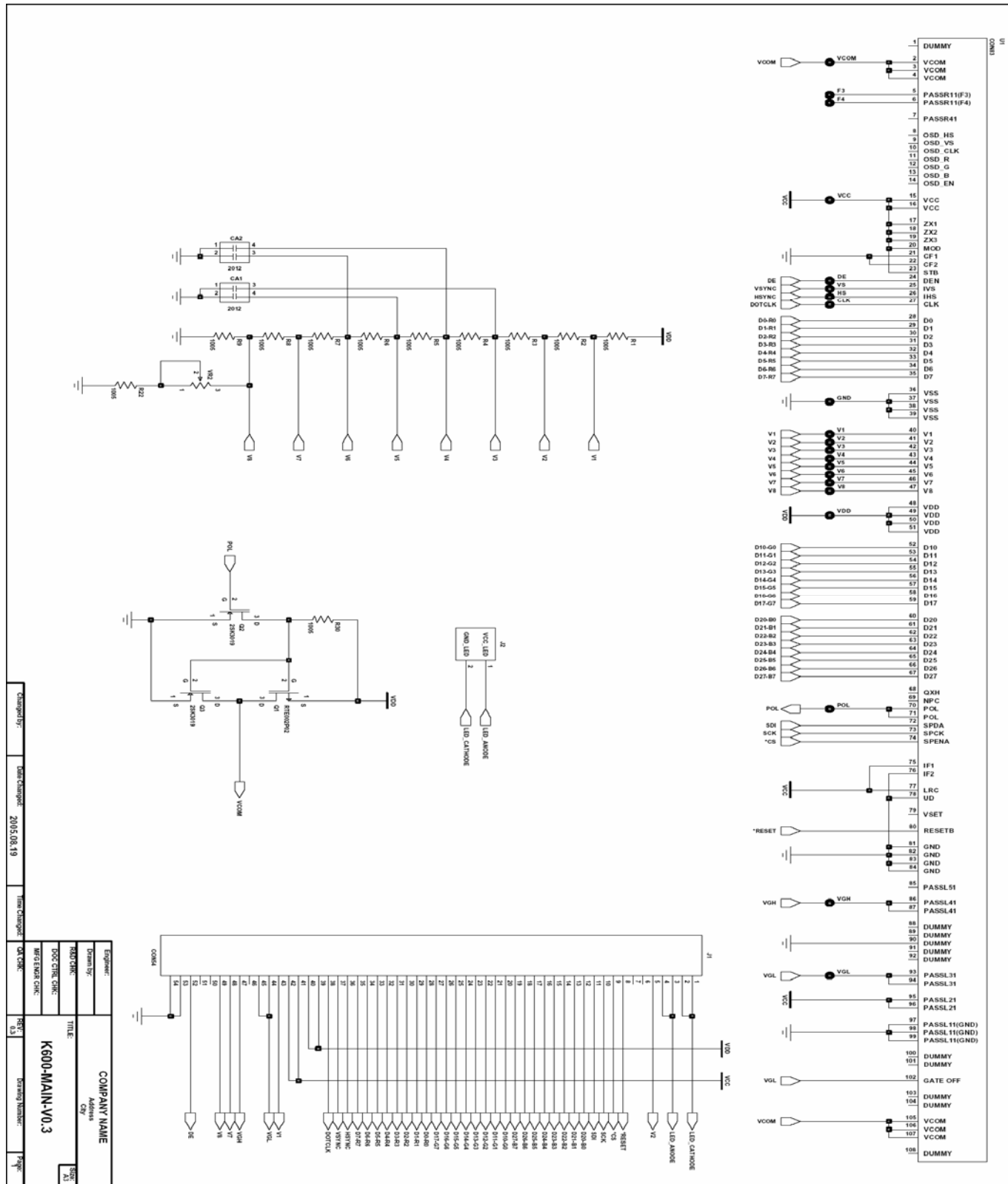

13. Packaging

13.1 Packaging

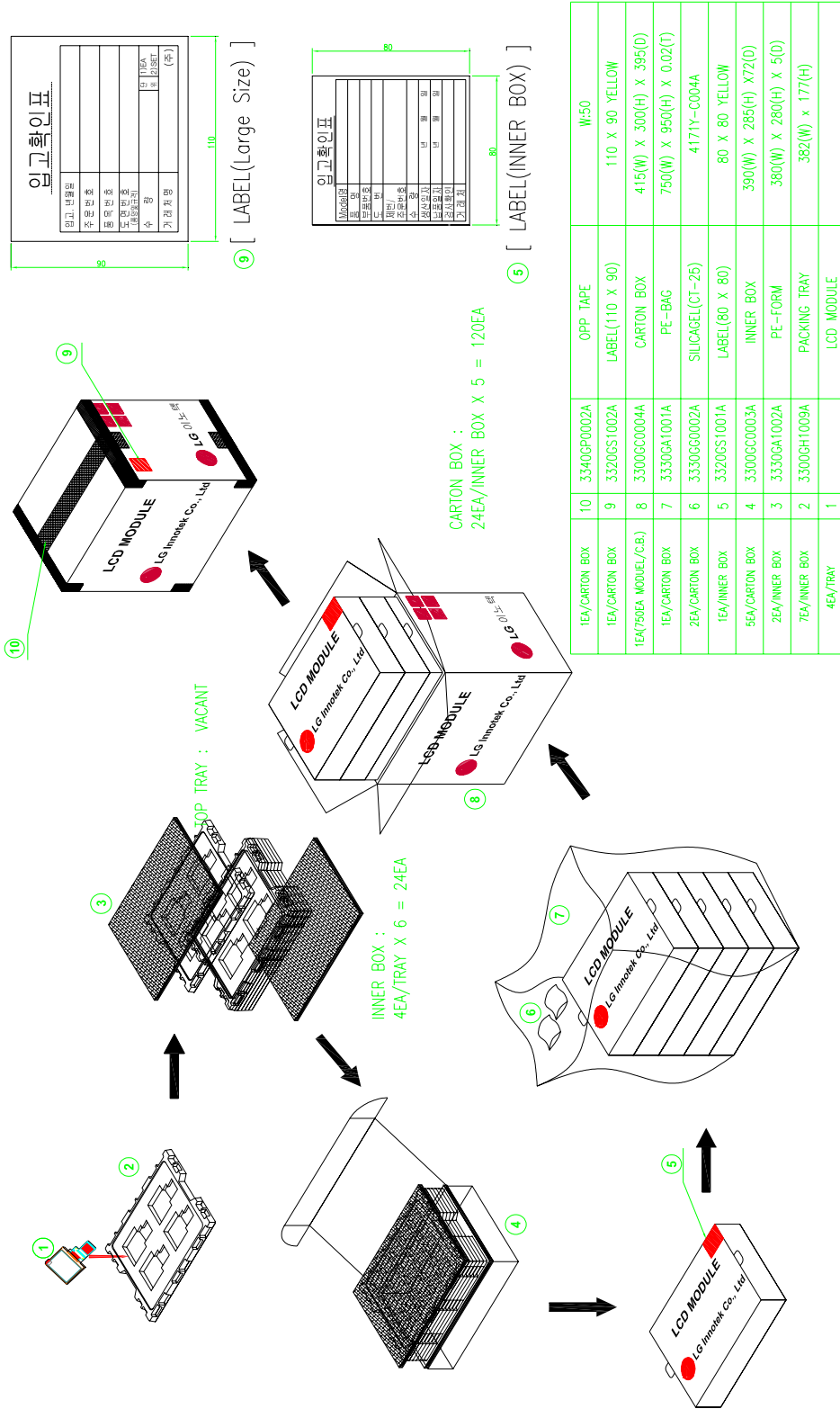

13.2 Designation of Lot Mark

Lot Mark

A	B	C	D	E
---	---	---	---	---

A : YEAR

B : MONTH

C, D : DATE

E : MAKER CODE

Note:

1. YEAR(A)

YEAR	2003	2004	2005	2006	2007	2008	2009	2010	2011	2012
Mark	3	4	5	6	7	8	9	0	1	2

2. MONTH(B)

MONTH	Jan.	Feb.	Mar.	Apr.	May.	Jun.	Jul.	Aug.	Sep.	Oct.	Nov.	Dec.
Mark	1	2	3	4	5	6	7	8	9	A	B	C

3. DATE(C,D)

1~31

4. MAKER CODE(E)



Caution AND Handling Precaution

To avoid causing extended damages such as accidents resulting in injury or death, fire accidents, or social damages or social damages if the LCD module fails, LG Innotek Display Technology is always endeavor to maintain sufficient quality of the LCD module in process of designing and manufacturing.

Please pay attention to the followings when you use this TFT LCD Module.



Safety

1) DISASSEMBLING OR MODIFICATION

Do not disassemble or modify the modules. Sensitive parts inside LCD module may be damaged, and dusts or scratches may mar the displays. Toshiba Matsushita Display Technology does not warrant the modules, if customer disassembled or modified them.

2) BREAKAGE OF LCD PANEL

Do not Ingest liquid crystal material, Do not Inhale this material, and Do not Permit this material to contact the skin, if glass of LCD panel is broken. If liquid crystal material contacts the skin, mouth or clothing, take the following actions immediately.

In case contact to the eye or mouth, rinse with large amount of running water for more than 15 minutes. In case contact to the skin or clothing, wipe it off immediately and wash with soap and large amount of running water for more than 15 minutes. The skin or closing may be damaged if liquid crystal material is left adhered. In case ingestion, rinse out the mouth well with water. After spewing up by drinking large amount of water, get medical treatment.

3) GLASS OF LCD PANEL

Be careful with chips of Glass that may cause injuring fingers or skin, when the glass is broken.

4) ABSOLUTE MAXIMUM RATINGS

Do not exceed the absolute maximum rating values under the worst probable conditions caused by the supply voltage variation, input voltage variation, variation in parts' constants, environmental temperature, etc., otherwise LCD module may be damaged.

5) POWER PROTECTION CIRCUIT

Employ protection circuit for power supply, whenever the specification specifies it.

A suitable protection circuit should be applied, based on each system design.

A fuse is not fitted to this module. Therefore, without a suitable power-supply protection device, dust or partial circuit failure may cause overheating and/or burning, which may lead to injury.

6) DISPOSAL

Always comply with all applicable environmental regulations, when disposing of the LCD.

7) EDGES OF PARTS

Be careful with edges of glass parts and metal frame, it may cause injuring.

For designing the system, give special consideration that the wiring and parts do not touch those edges.

8) RECOMMENDED OPERATING CONDITIONS

Don't exceed "the recommended operation conditions" in this specification. The performance and quality of the LCD module are warranted only when the LCD module is used within "the recommended operation conditions". To use the LCD module over "the recommended operation conditions" may have bad influence on the characteristics and reliability of the LCD module and may shorten the life of the LCD module.

Therefore, when designing the whole set, not to be over "the recommended operation conditions", you should fully take care of supply voltage change, characteristic of connection parts, surge of input-and-output line, and surrounding temperature.



Installation in Assembly

1. ESD (ELECTRO-STATIC DISCHARGE) PREVENTION

The circuit used in LCD module is very sensitive to ESD. The following caution should be taken when installing LCD module to an enclosure of the system in order to prevent damage of circuit used in LCD module.

1) HUMIDITY

Ambient humidity of working area is recommended to be higher than 50%(RH) in order to avoid ESD.

2) GROUNDING

- Person handling LCD modules should be grounded with wrist band.
- Tools like soldering iron and screw drivers and working benches should be grounded.
- Grounded electro-conductive mats are recommended to be covered on the floor of working area and surface of working benches.
- The grounding should be done through a resistor of 0.5~1Mohms in order to prevent spark of ESD.

3) Be careful with touching metal portion of testing instruments in order to prevent unnecessary ESD.

4) Do not touch the electrode area of PCB and electrical parts like LSI, capacitor, connector pin, etc.

5) IONIZER

Using ionizer (an antistatic blower) is recommended at working area in order to reduce electro-static voltage.

6) REMOVING PROTECTION FILM

When removing protection film from LCD panel, peel off the tag slowly (more than one second) while blowing with ionizer toward the peeling face to minimize ESD which may damage electrical circuit.

2. DUST AND STAIN PREVENTION

1) WORKING AREA

Reduce dust level in working area. Especially the level of metal particle should be decreased, otherwise electrical circuit in LCD module may be damaged due to short circuit by metal particles.

2) FINGER PRINT

Use finger stalls or soft and dust-free gloves in order to keep clean appearance of LCD module when handled for incoming inspection and assembly.

3) PROTECTION FILM

LCD module may be shipped with "protection film" on LCD panel in order to prevent from scratches and dust. It is recommended to remove the film at later process of assembling.

4) WIPING OFF DUST ON THE PANEL

When LCD panel becomes dirty, wipe the panel surface off softly with absorbent cotton or another soft cloth. If necessary, breathe upon the panel surface and then wipe off immediately and softly again. Be careful not to spill organic solvents into the inside of LCD module. The solvents may damage driver IC and PCB area used inside module. The polarizer laminated to LCD panel and adhesives may be damaged by the solvents, so do not use any organic solvents for wiping off LCD panel.

5) ADHESIVE ON LCD PANEL

Be careful not to attach adhesive, grease, etc., on LCD panel, because it is difficult to remove them without any damages on LCD panel.

6) WATER SPOTS ON THE PANEL

Avoid the dewing or water condensation.

Wipe off a spot or spots of water or mist on LCD panel softly with absorbent cotton or another cloth as soon as possible if happened, otherwise discoloration or stain may be caused. And, damage may occur if water penetrates the inside.

3. INSTALLING LCD MODULE TO THE ENCLOSURE

1) INSTALLING LCD MODULE TO THE ENCLOSURE

Do not bend or twist LCD module even momentarily when the LCD module is installed into the system. Bending or twisting the LCD module may cause permanent damage.

When the FPC is bent, the radius of FPC curvature must be more than value of recommendation to prevent bending and twisting forces from affecting the connection of FPC.

Even temporary bending or twisting sometimes causes damage.

2) INTERFACE

Do not fasten screws, with catching interface FPC between LCD module and the enclosure. This may cause bending of LCD module, or become the cause of a failure by damaging FPC.

4. MECHANICAL FORCES

1) CARRY

Hold the side of the plastic frame when you carry an LCD module by hand. If an LCD is carried using the FPC, it is likely to be damaged and the LCD will then malfunction. If you turn on the LCD with a broken FPC, it may cause smoke or burning.

Protection (eg gloves) for fingers and hands is recommended to avoid injury by broken glass.

2) STRONG MECHANICAL SHOCK

Avoid strong mechanical shock, such as dropping the LCD from the work bench, or knocking it against a hard object.

These may cause the glass panel to crack, or cause other mis-operation.

3) EXCESSIVE FORCE

Avoid applying excessive force, like pushing the surface of LCD panel. This may cause scratches or breakage of the panel, or a failure of the module.

4) SCRATCHES ON THE PANEL

Do not put heavy object such as tools, books, etc., and do not pile up LCD modules. Be careful not to touch the surface of the polarizer with any hard and sharp object. These parts are so sensitive and can easily be scratched, even if protected by a film.

5) Connector

When inserting or disconnecting the connector into a connector of the LCD module, care should be taken to ensure that no strong external force is applied to the connector on the LCD module side.

A strong external force applied to the connector or the FPC may damage their connections.

When assembling a module into a system, pay extra attention to ensure that no part such as the FPC etc. should be caught between the case of the system and the module. Make sure that the input signal connector of a module is securely and correctly connected to the connector on the system, not skewed, or incompletely connected.

Inputting a signal etc. into the module with connectors incorrectly inserted may cause a circuit component or components to malfunction.

6) FPC

When inserting or disconnecting the connector of the LCD module into a connector of the system, care should be taken to ensure that no strong external force is applied to the FPC on the LCD module side. A strong external force applied to the FPC may damage their connections.

When assembling a module into a system, pay extra attention to ensure that no part such as the FPC etc. should be caught between the case of the system and the module.

Make sure that the input signal connector of a module is securely and correctly connected to the connector on the system, not skewed, or incompletely connected. Inputting a signal etc. into the module with connectors incorrectly inserted may cause a circuit component or components to malfunction. Be careful not to pull or damage the FPC cables, to avoid mechanical damage in FPC and connection part of FPC and cell.

5. OPERATION

1) POWER SUPPLY

Power supplies should always be turned off during the assembly process.

Do not connect or disconnect the power cables and connectors with power applied to LCD module. This may cause damage to the LCD module circuit.

In operating module at the inspection process, and so on, the supply voltage and signals of driving device must satisfy the sequence of power supplies and signals described in this specifications.

2) GAS

Do not expose the LCD module to any gas which is not normally contained in the atmosphere, it may cause mis-operation or defects.

3) USED FOR LONG TERM

When a LCD module is used for a long term, the characteristics of LCD module might be changed and it may be out of the standard of "4.3 Optical Specifications" due to LED discoloration.

LED has the characteristics of shifting optical characteristics by the long term use.



Transportation and Storage

1) TEMPERATURE

Do not store LCD modules in a high temperature and high humidity condition, higher than 35°C and 70%(RH) for a long term, meaning about one month or more, otherwise this may deteriorate the quality of the display. When you unavoidably store LCD modules for a long time, store between 0 and 35°C, with a relative humidity 70% or lower.

2) LOW TEMPERATURE

Be careful not to leave it where the temperature is below specified storage temperature because the liquid crystal of the display panel may be damaged.

3) ULTRA VIOLET RAY

Store LCD module without exposure to direct sunlight or fluorescent lamps in order to prevent the module from strong ultra violet ray.

4) CLEANLINESS

Keep the LCD module in clean place, because any dust, hard particle may damage the polarizer, or dust invades the inside of the LCD module.

5) CONDENSATION OF WATER

The modules should be stored under a condition where no condensation of water is allowed. It may cause mis-operation or defects. Be especially careful not to make a module work under the condition that condensation of water appears.

6) PACKAGING

When you must re-package a LCD module after it has been removed from the original packaging, it is recommended to re-pack using the original package box and package material.