

IN74LS157

Quad 2-Input Data Selector/Multiplexer

This monolithic data selector/multiplexer contains inverters and drivers to supply full on-chip data selection to the four output gates. A separate strobe input is provided. A 4-bit word is selected from one of two sources and is routed to the four outputs. The LS157 has the same functions and pin connections as the LS257 but the latter is provided with 3-state outputs.

- Buffered Inputs and Outputs
- Common Strobe/Select input for all 4 circuits

N SUFFIX PLASTIC

D SUFFIX SOIC

ORDERING INFORMATION

IN74LS157N Plastic
 IN74LS157D SOIC
 T_A = 0° to 70° C for all packages

LOGIC DIAGRAM

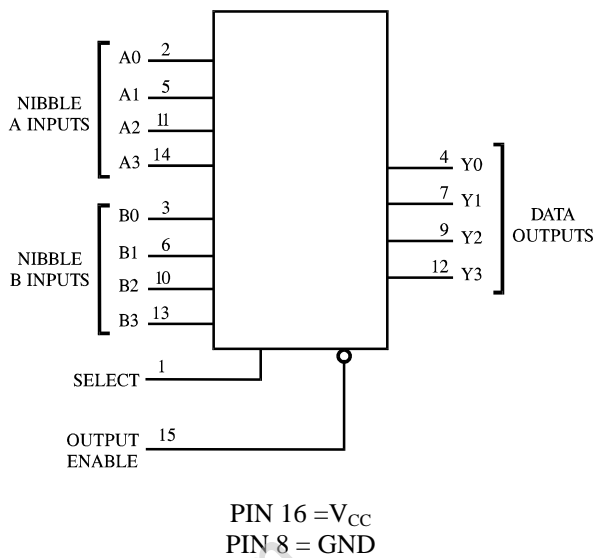

PIN ASSIGNMENT

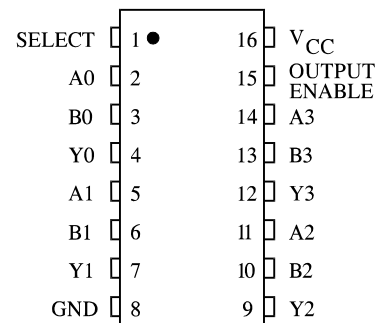

FUNCTION TABLE

| Inputs | | Outputs Y0-Y3 |
|---------------|--------|------------------|
| Output Enable | Select | |
| H | X | L |
| L | L | A0-A3 |
| L | H | B0-B3 |

X=don't care
 A0-A3,B0-B3=the levels of the respective Data-Word Inputs

MAXIMUM RATINGS*

| Symbol | Parameter | Value | Unit |
|------------------|---------------------------|-------------|------|
| V _{CC} | Supply Voltage | 7.0 | V |
| V _{IN} | Input Voltage | 7.0 | V |
| V _{OUT} | Output Voltage | 5.5 | V |
| T _{stg} | Storage Temperature Range | -65 to +150 | °C |

*Maximum Ratings are those values beyond which damage to the device may occur. Functional operation should be restricted to the Recommended Operating Conditions.

RECOMMENDED OPERATING CONDITIONS

| Symbol | Parameter | Min | Max | Unit |
|-----------------|---------------------------|------|------|------|
| V _{CC} | Supply Voltage | 4.75 | 5.25 | V |
| V _{IH} | High Level Input Voltage | 2.0 | | V |
| V _{IL} | Low Level Input Voltage | | 0.8 | V |
| I _{OH} | High Level Output Current | | -0.4 | mA |
| I _{OL} | Low Level Output Current | | 8.0 | mA |
| T _A | Ambient Temperature Range | 0 | +70 | °C |

DC ELECTRICAL CHARACTERISTICS over full operating conditions

| Symbol | Parameter | Test Conditions | Guaranteed Limit | | Unit | |
|-----------------|------------------------------|---|------------------|------|------|----|
| | | | Min | Max | | |
| V _{IK} | Input Clamp Voltage | V _{CC} = min, I _{IN} = -18 mA | | -1.5 | V | |
| V _{OH} | High Level Output Voltage | V _{CC} = min, I _{OH} = -0.4 mA | 2.7 | | V | |
| V _{OL} | Low Level Output Voltage | V _{CC} = min, I _{OL} = 4 mA | | 0.4 | V | |
| | | V _{CC} = min, I _{OL} = 8 mA | | 0.5 | | |
| I _{IH} | High Level Input Current | V _{CC} = max | for pins 1,15 | | 40 | μA |
| | | V _{IN} = 2.7 V | A or B input | | 20 | |
| | | V _{CC} = max | for pins 1,15 | | 0.2 | mA |
| I _{IL} | Low Level Input Current | V _{CC} = max | for pins 1,15 | | -0.8 | mA |
| | | V _{IN} = 0.4 V | A or B input | | -0.4 | |
| I _O | Output Short Circuit Current | V _{CC} = max, V _O = 0 V (Note 1) | -20 | -100 | mA | |
| I _{CC} | Supply Current | V _{CC} = max (Note 2) | | 16 | mA | |

Note 1: Not more than one output should be shorted at a time, and the duration should not exceed one second.

Note 2: I_{CC} is measured with all outputs open, and 4.5 V applied to all inputs.

AC ELECTRICAL CHARACTERISTICS ($T_A=25^{\circ}\text{C}$, $V_{CC} = 5.0\text{ V}$, $C_L = 15\text{ pF}$, $R_L = 2\text{ k}\Omega$, $t_r = 15\text{ ns}$, $t_f = 6.0\text{ ns}$)

| Symbol | Parameter | Min | Max | Unit |
|-----------|--|-----|-----|------|
| t_{PLH} | Propagation Delay, Input A or B to Output Y | | 14 | ns |
| t_{PHL} | Propagation Delay, Input A or B to Output Y | | 14 | ns |
| t_{PLH} | Propagation Delay, Select to Output Y | | 23 | ns |
| t_{PHL} | Propagation Delay, Select to Output Y | | 27 | ns |
| t_{PLH} | Propagation Delay, Output Enable to Output Y | | 20 | ns |
| t_{PHL} | Propagation Delay, Output Enable to Output Y | | 21 | ns |

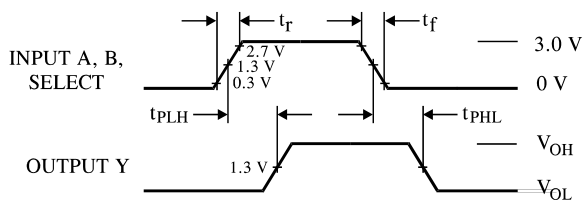

Figure 1. Switching Waveforms

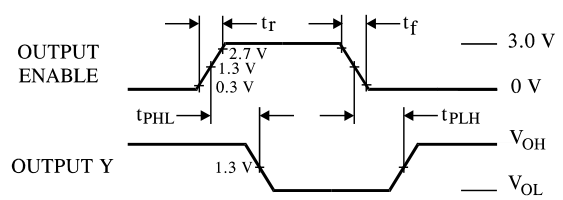
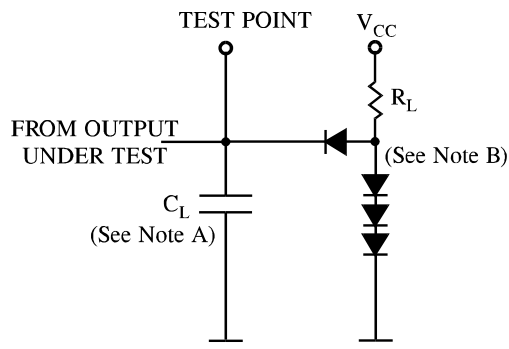

Figure 2. Switching Waveforms



NOTES A. C_L includes probe and jig capacitance.
 B. All diodes are 1N916 or 1N3064.

Figure 3. Test Circuit

**N SUFFIX PLASTIC DIP
(MS - 001BB)**

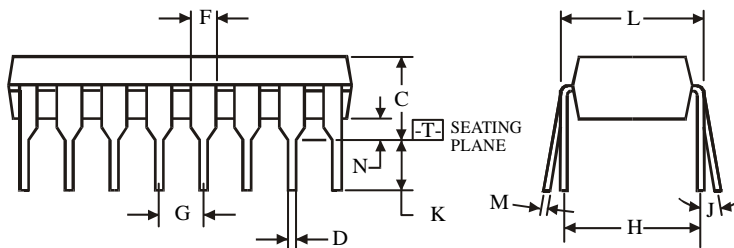
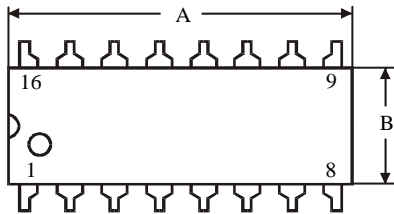
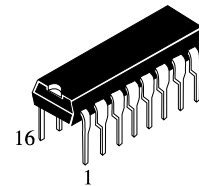

$\oplus 0.25 (0.010) \text{ (M) T}$

NOTES:

- Dimensions "A", "B" do not include mold flash or protrusions.
Maximum mold flash or protrusions 0.25 mm (0.010) per side.

| Symbol | Dimension, mm | |
|--------|---------------|-------|
| | MIN | MAX |
| A | 18.67 | 19.69 |
| B | 6.1 | 7.11 |
| C | | 5.33 |
| D | 0.36 | 0.56 |
| F | 1.14 | 1.78 |
| G | 2.54 | |
| H | 7.62 | |
| J | 0° | 10° |
| K | 2.92 | 3.81 |
| L | 7.62 | 8.26 |
| M | 0.2 | 0.36 |
| N | 0.38 | |

**D SUFFIX SOIC
(MS - 012AC)**

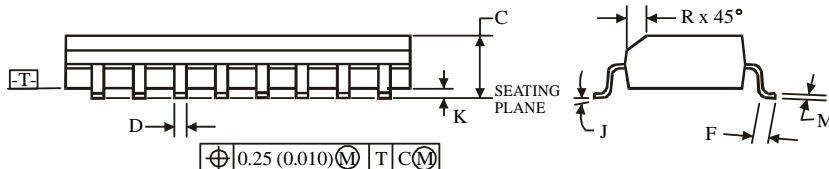
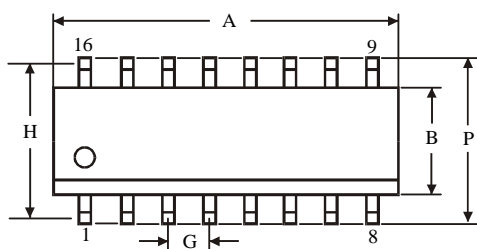
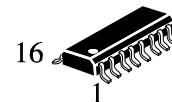

$\oplus 0.25 (0.010) \text{ (M) T C (M)}$

NOTES:

- Dimensions A and B do not include mold flash or protrusion.
- Maximum mold flash or protrusion 0.15 mm (0.006) per side for A; for B - 0.25 mm (0.010) per side.

| Symbol | Dimension, mm | |
|--------|---------------|------|
| | MIN | MAX |
| A | 9.8 | 10 |
| B | 3.8 | 4 |
| C | 1.35 | 1.75 |
| D | 0.33 | 0.51 |
| F | 0.4 | 1.27 |
| G | 1.27 | |
| H | 5.72 | |
| J | 0° | 8° |
| K | 0.1 | 0.25 |
| M | 0.19 | 0.25 |
| P | 5.8 | 6.2 |
| R | 0.25 | 0.5 |