

IN74LV08

Quad 2-Input AND Gate

The IN74LV08 is low-voltage Si-gate CMOS device and is pin and function compatible with 74HC/HCT08A.

The IN74LV08 provides the 2-input AND function.

- Optimized for Low Voltage applications: 1.2 to 3.6 V
- Accepts TTL input levels between $V_{CC} = 2.7\text{ V}$ and $V_{CC} = 3.6\text{ V}$
- Low Input Current

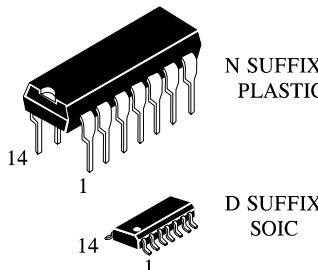

ORDERING INFORMATION

IN74LV08N	Plastic
IN74LV08D	SOIC

$T_A = -40^\circ \div 125^\circ\text{C}$ for all packages

LOGIC DIAGRAM

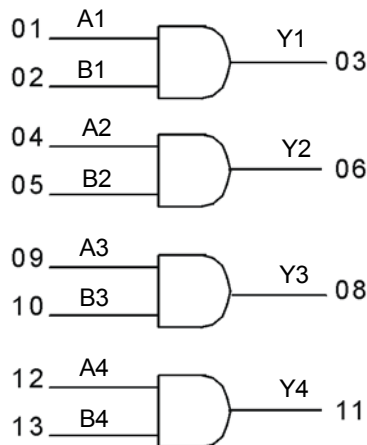

PIN 14 = V_{CC}
PIN 7 = GND

PIN ASSIGNMENT

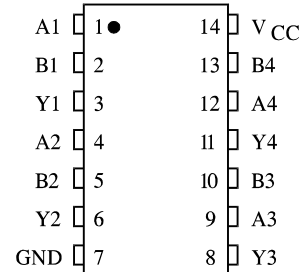

FUNCTION TABLE

Input		Output
A	B	$Y = A * B$
L	L	L
L	H	L
H	L	L
H	H	H

H - high level
L - low level

MAXIMUM RATINGS*

Symbol	Parameter	Value	Unit
V _{CC}	DC supply voltage (Referenced to GND)	-0.5 ÷ +5.0	V
I _{IK} * ¹	DC input diode current	±20	mA
I _{OK} * ²	DC output diode current	±50	mA
I _O * ³	DC output source or sink current -bus driver outputs	±25	mA
I _{CC}	DC V _{CC} current for types with - bus driver outputs	±50	mA
I _{GND}	DC GND current for types with - bus driver outputs	±50	mA
P _D	Power dissipation per package, plastic DIP+ SOIC package+	750 500	mW
T _{stg}	Storage temperature	-65 ÷ +150	°C
T _L	Lead temperature, 1.5 mm from Case for 10 seconds (Plastic DIP), 0.3 mm (SOIC Package)	260	°C

*Maximum Ratings are those values beyond which damage to the device may occur. Functional operation should be restricted to the Recommended Operating Conditions.

+Derating - Plastic DIP: - 12 mW/°C from 70° to 125°C
SOIC Package: - 8 mW/°C from 70° to 125°C

*¹: V_I < -0.5V or V_I > V_{CC}+0.5V

*²: V_O < -0.5V or V_O > V_{CC}+0.5V

*³: -0.5V < V_O < V_{CC}+0.5V

RECOMMENDED OPERATING CONDITIONS

Symbol	Parameter	Min	Max	Unit
V _{CC}	DC Supply Voltage (Referenced to GND)	1.2	3.6	V
V _{IN} , V _{OUT}	DC Input Voltage, Output Voltage (Referenced to GND)	0	V _{CC}	V
T _A	Operating Temperature, All Package Types	-40	+125	°C
t _r , t _f	Input Rise and Fall Time			ns
	V _{CC} =1.2 V	0	1000	
	V _{CC} =2.0 V	0	700	
	V _{CC} =3.0 V	0	500	
	V _{CC} =3.6 V	0	400	

This device contains protection circuitry to guard against damage due to high static voltages or electric fields. However, precautions must be taken to avoid applications of any voltage higher than maximum rated voltages to this high-impedance circuit. For proper operation, V_{IN} and V_{OUT} should be constrained to the range GND ≤ (V_{IN} or V_{OUT}) ≤ V_{CC}.

Unused inputs must always be tied to an appropriate logic voltage level (e.g., either GND or V_{CC}). Unused outputs must be left open.

DC ELECTRICAL CHARACTERISTICS (Voltages Referenced to GND)

Symbol	Parameter	Test Conditions	V _{CC} , V	Guaranteed Limit						Unit		
				25°C		-40°C ÷ 85°C		-40°C ÷ 125°C				
				min	max	min	max	min	max			
V _{IH}	High-Level Input Voltage		1.2	0.9	-	0.9	-	0.9	-	V		
			2.0	1.4	-	1.4	-	1.4	-			
			3.0	2.1	-	2.1	-	2.1	-			
			3.6	2.5	-	2.5	-	2.5	-			
V _{IL}	Low-Level Input Voltage		1.2	-	0.3	-	0.3	-	0.3	V		
			2.0	-	0.6	-	0.6	-	0.6			
			3.0	-	0.9	-	0.9	-	0.9			
			3.6	-	1.1	-	1.1	-	1.1			
V _{OH}	High-Level Output Voltage	V _I = V _{IL} or V _{IH} I _O = -50 µA	1.2	1.1	-	1.0	-	1.0	-	V		
			2.0	1.92	-	1.9	-	1.9	-			
			3.0	2.92	-	2.9	-	2.9	-			
			3.6	3.52	-	3.5	-	3.5	-			
				V _I = V _{IL} or V _{IH} I _O = -6.0 mA	3.0	2.48	-	2.34	-	2.20	-	V
		V _{OL}	Low-Level Output Voltage	V _I = V _{IL} or V _{IH} I _O = 50 µA	1.2	-	0.09	-	0.1	-	0.1	V
2.0	-				0.09	-	0.1	-	0.1			
3.0	-				0.09	-	0.1	-	0.1			
3.6	-				0.09	-	0.1	-	0.1			
				V _I = V _{IL} or V _{IH} I _O = 6.0 mA	3.0	-	0.33	-	0.4	-	0.5	V
I _{IL}	Low-Level Input Leakage Current			V _I = 0 V	3.6	-	-0.1	-	-1.0	-	-1.0	µA
I _{IH}	High-Level Input Leakage Current	V _I = V _{CC}	3.6	-	0.1	-	1.0	-	1.0	µA		
I _{CC}	Quiescent Supply Current (per Package)	V _I = 0 B or V _{CC} I _O = 0 µA	3.6	-	2.0	-	20	-	40	µA		

AC ELECTRICAL CHARACTERISTICS ($C_L=50\text{ pF}$, $t_{LH} = t_{HL} = 6.0\text{ ns}$, $V_{IL}=0\text{V}$, $V_{IH}=V_{CC}$, $R_L=1\text{k}\Omega$)

Symbol	Parameter	V_{CC}	Guaranteed Limit						Unit
		V	25°C		-40°C ÷ 85°C		-40°C ÷ 125°C		
			min	max	min	max	min	max	
t_{THL} , (t_{TLH})	Output Transition Time, Any Output (Figure 1)	1.2	-	60	-	75	-	90	ns
		2.0	-	16	-	20	-	24	
		*	-	10	-	13	-	15	
t_{PHL} , (t_{PLH})	Propagation Delay, Input A to Output Y (Figure 1)	1.2	-	135	-	405	-	405	
		2.0	-	23	-	28	-	34	
		*	-	14	-	18	-	21	
C_I	Input Capacitance	3.0	-	7.0	-	-	-	-	pF
C_{PD}	Power Dissipation Capacitance (Per Gate)	$T_A=25^\circ\text{C}$, $V_I=0\text{V}\div V_{CC}$						pF	
		44							

* - $V_{CC} = (3.3 \pm 0.3)\text{ V}$
 Used to determine the no-load dynamic power consumption:
 $P_D = C_{PD}V_{CC}^2f_i + \sum(C_LV_{CC}^2f_o)$, f_i -input frequency, f_o - output frequency (MHz)
 $\sum(C_LV_{CC}^2f_o)$ – sum of the outputs

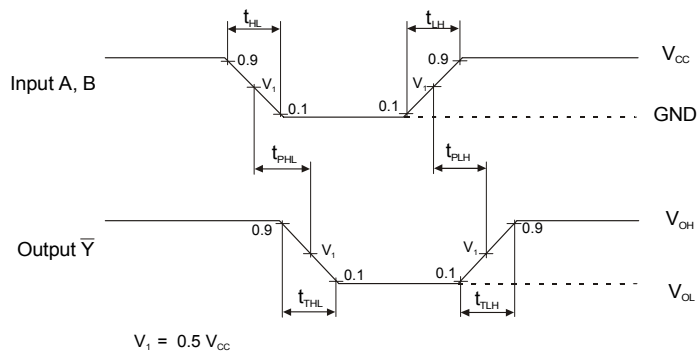

Figure 1. Switching Waveforms

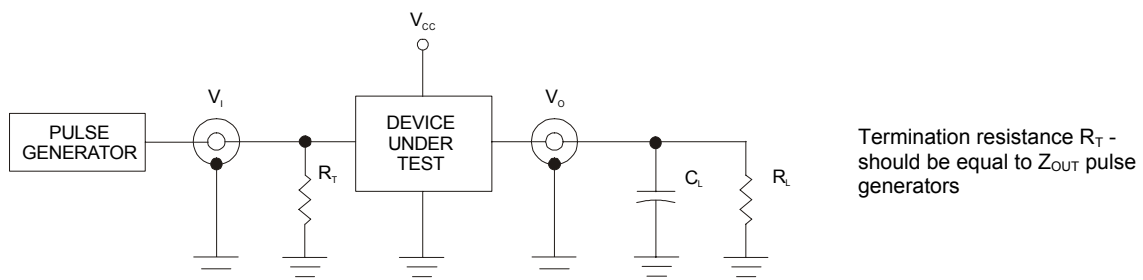
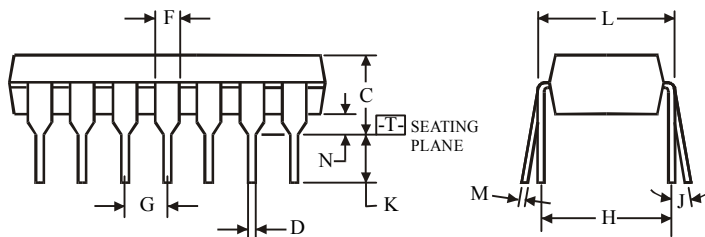
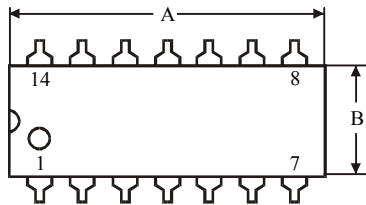

Figure 2. Test Circuit

**N SUFFIX PLASTIC DIP
(MS - 001AA)**



$\oplus 0.25 (0.010) \text{ (M) T}$

NOTES:

- Dimensions "A", "B" do not include mold flash or protrusions.
Maximum mold flash or protrusions 0.25 mm (0.010) per side.

Symbol	Dimension, mm	
	MIN	MAX
A	18.67	19.69
B	6.1	7.11
C		5.33
D	0.36	0.56
F	1.14	1.78
G	2.54	
H	7.62	
J	0°	10°
K	2.92	3.81
L	7.62	8.26
M	0.2	0.36
N	0.38	

**D SUFFIX SOIC
(MS - 012AB)**

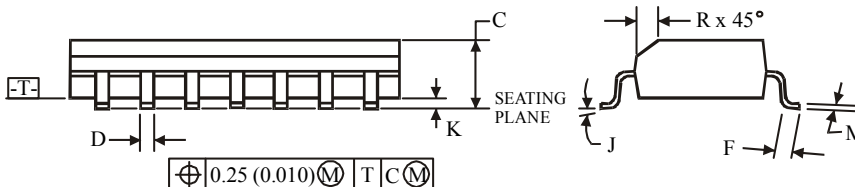
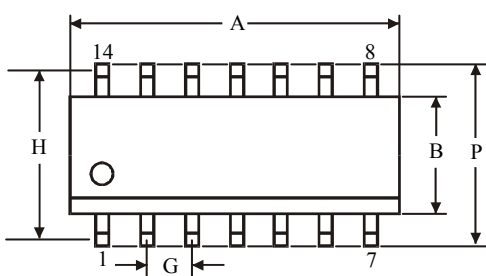

$\oplus 0.25 (0.010) \text{ (M) T C (M)}$

NOTES:

- Dimensions A and B do not include mold flash or protrusion.
- Maximum mold flash or protrusion 0.15 mm (0.006) per side for A; for B - 0.25 mm (0.010) per side.

Symbol	Dimension, mm	
	MIN	MAX
A	8.55	8.75
B	3.8	4
C	1.35	1.75
D	0.33	0.51
F	0.4	1.27
G	1.27	
H	5.27	
J	0°	8°
K	0.1	0.25
M	0.19	0.25
P	5.8	6.2
R	0.25	0.5