

8-BIT SERIAL-IN/PARALLEL-OUT SHIFT REGISTER

IN74LV164

The IN74LV164 is a low-voltage Si-gate CMOS device and is pin and function compatible with the IN74HC/HCT164.

The IN74LV164 is an 8-bit edge-triggered shift register with serial data entry and an output from each of the eight stages. Data is entered serially through one of two inputs (DSA or DSB); either input can be used as an active HIGH enable for data entry through the other input. Both inputs must be connected together or an unused input must be tied HIGH.

Data shifts one place to the right on each LOW-to-HIGH transition of the clock (CP) input and enters into Q₀, which is the logical AND of the two data inputs (DSA, DSB) that existed one set-up time prior to the rising clock edge.

A LOW on the master reset (\overline{MR}) input overrides all other inputs and clears the register asynchronously, forcing all outputs LOW.

- Outputs Directly Interface to CMOS, NMOS, and TTL
- Operating Voltage Range: 1.2 to 5.5 V
- Low Input Current: 1.0 μ A, 0.1 μ A at T = 25 °C
- Output Current: 6 mA at V_{CC} = 3.0 V; 12 mA at V_{CC} = 4.5 V
- High Noise Immunity Characteristic of CMOS Devices

N SUFFIX
PLASTIC DIP

D SUFFIX
SO

ORDERING INFORMATION

IN74LV164N Plastic
IN74LV164D SOIC

T_A = -40° to 125° C for all packages

LOGIC DIAGRAM

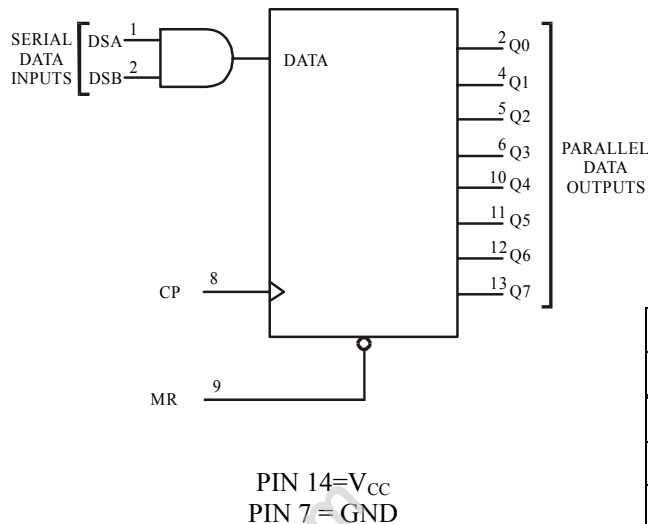

PIN ASSIGNMENT

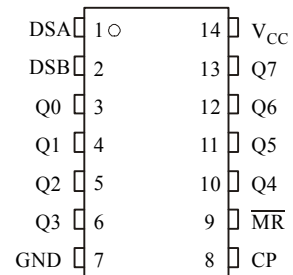

FUNCTION TABLE

Inputs				Outputs		
\overline{MR}	CP	DSA	DSB	Q0	Q1 ... Q7	
L	X	X	X	L	L ... L	
H		L	L	L	Q0 ... Q6	
H		L	H	L	Q0 ... Q6	
H		H	L	L	Q0 ... Q6	
H		H	H	H	Q0 ... Q6	

H = high voltage level
L = low voltage level
X = don't care

MAXIMUM RATINGS*

Symbol	Parameter	Value	Unit
V_{CC}	DC supply voltage	-0.5 to + 7.0	V
I_{IK}^{*1}	DC Input diode current	± 20	mA
I_{OK}^{*2}	DC Output diode current	± 50	mA
I_O^{*3}	DC Output source or sink current	± 25	mA
I_{CC}	V_{CC} current	± 50	mA
I_{GND}	GND current	± 50	mA
P_D	Power dissipation per package: *4 Plastic DIP SO	750 500	mW
Tstg	Storage Temperature	-65 to +150	°C
T_L	Lead Temperature, 1.5 mm (Plastic DIP Package), 0.3 mm (SO Package) from Case for 4 Seconds	260	°C

*Maximum Ratings are those values beyond which damage to the device may occur. Functional operation should be restricted to the Recommended Operating Conditions.

*¹ $V_I < -0.5\text{ V}$ or $V_I > V_{CC} + 0.5\text{ V}$.

*² $V_O < -0.5\text{ V}$ or $V_O > V_{CC} + 0.5\text{ V}$.

*³ $-0.5\text{ V} < V_O < V_{CC} + 0.5\text{ V}$.

*⁴ Derating - Plastic DIP: - 12 mW/°C from 70° to 125°C
SO Package: - 8 mW/°C from 70° to 125°C

RECOMMENDED OPERATING CONDITIONS

Symbol	Parameter	Min	Max	Unit
V_{CC}	DC Supply Voltage	1.2	5.5	V
V_I	Input Voltage	0	V_{CC}	V
V_O	Output Voltage	0	V_{CC}	V
T_A	Operating Temperature, All Package Types	-40	+125	°C
t_r, t_f	Input Rise and Fall Time (Figure 1)			ns
	$1.0\text{ V} \leq V_{CC} < 2.0\text{ V}$	0	500	
	$2.0\text{ V} \leq V_{CC} < 2.7\text{ V}$	0	200	
	$2.7\text{ V} \leq V_{CC} < 3.6\text{ V}$	0	100	
	$3.6\text{ V} \leq V_{CC} \leq 5.5\text{ V}$	0	50	

This device contains protection circuitry to guard against damage due to high static voltages or electric fields. However, precautions must be taken to avoid applications of any voltage higher than maximum rated voltages to this high-impedance circuit. For proper operation, V_{IN} and V_{OUT} should be constrained to the range $GND \leq (V_{IN}$ or $V_{OUT}) \leq V_{CC}$.

Unused inputs must always be tied to an appropriate logic voltage level (e.g., either GND or V_{CC}). Unused outputs must be left open.

DC ELECTRICAL CHARACTERISTICS (Voltages Referenced to GND)

Symbol	Parameter	Test conditions	V _{CC} V	Guaranteed Limit						Unit	
				25°C to -40°C		85°C		125°C			
				min	max	min	max	min	max		
V _{IH}	HIGH level input voltage		1.2	0.9	-	0.9	-	0.9	-	V	
			2.0	1.4	-	1.4	-	1.4	-		
			2.7	2.0	-	2.0	-	2.0	-		
			3.0	2.0	-	2.0	-	2.0	-		
			3.6	2.0	-	2.0	-	2.0	-		
			4.5	3.15	-	3.15	-	3.15	-		
			5.5	3.85	-	3.85	-	3.85	-		
V _{IL}	LOW level input voltage		1.2	-	0.3	-	0.3	-	0.3	V	
			2.0	-	0.6	-	0.6	-	0.6		
			2.7	-	0.8	-	0.8	-	0.8		
			3.0	-	0.8	-	0.8	-	0.8		
			3.6	-	0.8	-	0.8	-	0.8		
			4.5	-	1.35	-	1.35	-	1.35		
			5.5	-	1.65	-	1.65	-	1.65		
V _{OH}	HIGH level output voltage	V _I = V _{IH} or V _{IL} I _O = -100 μA	1.2	1.05	-	1.0	-	1.0	-	V	
			2.0	1.85	-	1.8	-	1.8	-		
			2.7	2.55	-	2.5	-	2.5	-		
			3.0	2.85	-	2.8	-	2.8	-		
			3.6	3.45	-	3.4	-	3.4	-		
			4.5	4.35	-	4.3	-	4.3	-		
V _{OH}	HIGH level output voltage	V _I = V _{IH} or V _{IL} I _O = -6.0 mA	3.0	2.48	-	2.40	-	2.20	-	V	
			V _I = V _{IH} or V _{IL} I _O = -12.0 mA	4.5	3.70	-	3.60	-	3.50	-	V
V _{OL}	LOW level output voltage	V _I = V _{IH} or V _{IL} I _O = 100 μA	1.2	-	0.15	-	0.2	-	0.2	V	
			2.0	-	0.15	-	0.2	-	0.2		
			2.7	-	0.15	-	0.2	-	0.2		
			3.0	-	0.15	-	0.2	-	0.2		
			3.6	-	0.15	-	0.2	-	0.2		
			4.5	-	0.15	-	0.2	-	0.2		
			5.5	-	0.15	-	0.2	-	0.2		
		V _I = V _{IH} or V _{IL} I _O = 6.0 mA	3.0	-	0.33	-	0.4	-	0.5	V	
			V _I = V _{IH} or V _{IL} I _O = 12.0 mA	4.5	-	0.40	-	0.55	-	0.65	V
I _I	Input current	V _I = V _{CC} or 0 V	5.5	-	±0.1	-	±1.0	-	±1.0	μA	
I _{CC}	Supply current	V _I = V _{CC} or 0 V I _O = 0 μA	5.5	-	8.0	-	80	-	160	μA	
I _{CC1}	Supply current	V _I = V _{CC} - 0.6 V	2.7	-	0.2	-	0.5	-	0.85	mA	
			3.6								

AC ELECTRICAL CHARACTERISTICS ($C_L=50$ pF, $t_r=t_f=2.5$ ns, $R_L=1$ k Ω)

Symbol	Parameter	Test conditions	V _{CC} V	Guaranteed Limit						Unit
				25°C to -40°C		85°C		125°C		
				min	max	min	max	min	max	
t _{PHL} , t _{PLH}	Propagation delay, CP to Qn	V _I = 0 V or V _I Figure 1 and 4	1.2	-	150	-	180	-	210	ns
			2.0	-	30	-	39	-	49	
			2.7	-	23	-	29	-	36	
			3.0	-	18	-	23	-	29	
			4.5	-	15	-	19	-	24	
t _{PHL}	Propagation delay, $\overline{\text{MR}}$ to Qn	V _I = 0 V or V _I Figure 1 and 4	1.2	-	150	-	180	-	210	ns
			2.0	-	30	-	39	-	49	
			2.7	-	23	-	29	-	36	
			3.0	-	18	-	23	-	29	
			4.5	-	15	-	19	-	24	
t _w	Pulse Width, CP or MR	V _I = 0 V or V _I Figure 1	1.2	100	-	130	-	160	-	ns
			2.0	28	-	34	-	41	-	
			2.7	21	-	25	-	30	-	
			3.0	17	-	20	-	24	-	
			4.5	14	-	17	-	20	-	
t _{su}	Setup Time, DSA or DSB to CP	V _I = 0 V or V _I Figure 3	1.2	60	-	80	-	100	-	ns
			2.0	19	-	22	-	26	-	
			2.7	13	-	16	-	19	-	
			3.0	11	-	13	-	15	-	
			4.5	9	-	11	-	13	-	
t _h	Hold Time, DSA or DSB to CP	V _I = 0 V or V _I Figure 3	1.2	50	-	50	-	50	-	ns
			2.0	5	-	5	-	5	-	
			2.7	5	-	5	-	5	-	
			3.0	5	-	5	-	5	-	
			4.5	5	-	5	-	5	-	
t _{rec}	Recovery Time, $\overline{\text{MR}}$ to CP	V _I = 0 V or V _I Figure 2	1.2	70	-	100	-	130	-	ns
			2.0	15	-	19	-	24	-	
			2.7	11	-	14	-	18	-	
			3.0	9	-	11	-	14	-	
			4.5	8	-	10	-	12	-	
f _{max}	Clock Frequency	V _I = 0 V or V _I Figure 1 and 4	1.2	-	2	-	1	-	1	MHz
			2.0	-	16	-	14	-	12	
			2.7	-	22	-	19	-	16	
			3.0	-	27	-	24	-	20	
			4.5	-	32	-	27	-	24	
C _I	Input capacitance		5.0	-	7.0	-	-	-	pF	
C _{PD}	Power dissipation capacitance	V _I = 0 V or V _{CC}	5.5	-	80	-	-	-	pF	

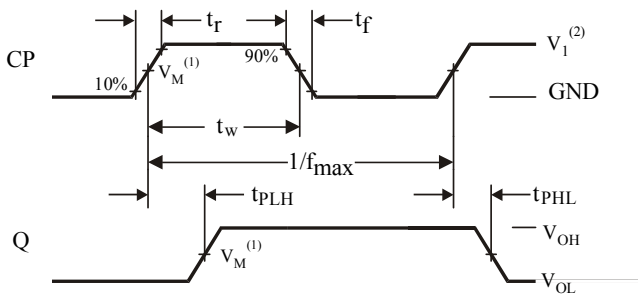

Figure 1. Switching Waveforms

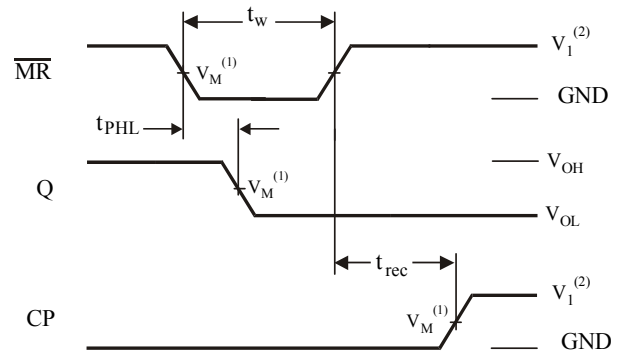

Figure 2. Switching Waveforms

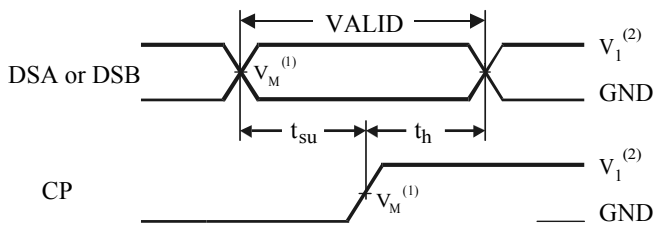
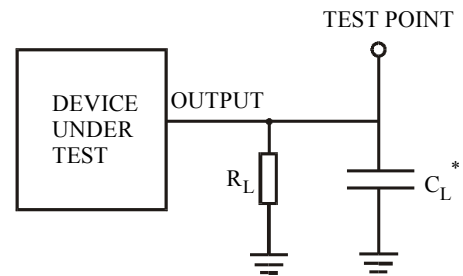

Figure 3. Switching Waveforms



* Includes all probe and jig capacitance

Figure 4. Test Circuit

Note:

- (1) $V_M = 1.5 \text{ V}$ at $V_{CC} = 2.7 \text{ V}$
 $V_M = 0.5 \cdot V_{CC}$ at $V_{CC} = 1.2 \text{ V}, 2.0 \text{ V}, 3.0 \text{ V}, 4.5 \text{ V}$
- (2) $V_1 = V_{CC}$ at $V_{CC} = 1.2 \text{ V}, 2.0 \text{ V}, 2.7 \text{ V}, 4.5 \text{ V}$
 $V_1 = 2.7 \text{ V}$ at $V_{CC} = 3.0 \text{ V}$

TIMING DIAGRAM

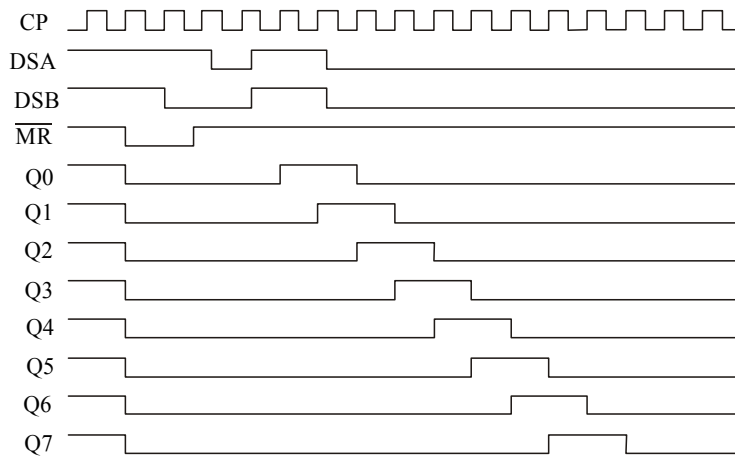

**N SUFFIX PLASTIC DIP
(MS - 001AA)**

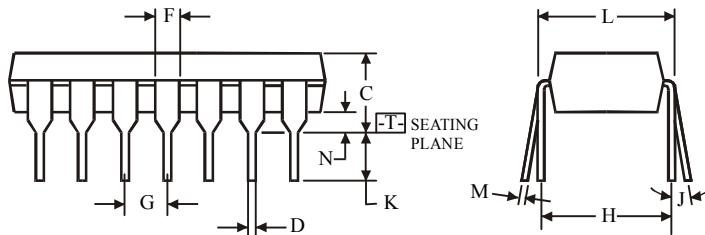
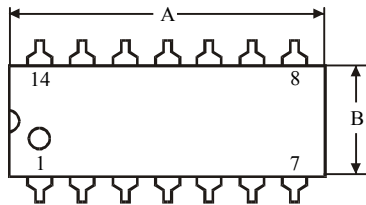
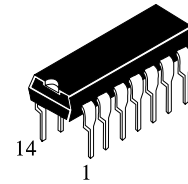

$$\oplus 0.25 (0.010) \text{ (M) } T$$

NOTES:

- Dimensions "A", "B" do not include mold flash or protrusions.
Maximum mold flash or protrusions 0.25 mm (0.010) per side.

Symbol	Dimension, mm	
	MIN	MAX
A	18.67	19.69
B	6.1	7.11
C		5.33
D	0.36	0.56
F	1.14	1.78
G	2.54	
H	7.62	
J	0°	10°
K	2.92	3.81
L	7.62	8.26
M	0.2	0.36
N	0.38	

**D SUFFIX SOIC
(MS - 012AB)**

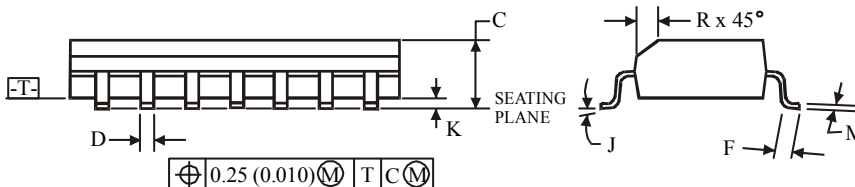
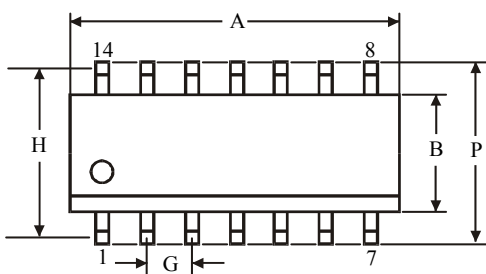
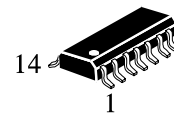

$$\oplus 0.25 (0.010) \text{ (M) } T \text{ C (M)}$$

NOTES:

- Dimensions A and B do not include mold flash or protrusion.
- Maximum mold flash or protrusion 0.15 mm (0.006) per side for A; for B - 0.25 mm (0.010) per side.

Symbol	Dimension, mm	
	MIN	MAX
A	8.55	8.75
B	3.8	4
C	1.35	1.75
D	0.33	0.51
F	0.4	1.27
G	1.27	
H	5.27	
J	0°	8°
K	0.1	0.25
M	0.19	0.25
P	5.8	6.2
R	0.25	0.5