

IN75232N/D

EIA-232-D INTERFACE 1 CHIP IC

Description

The IN75232N, IN75232D are monolithic device containing 3 independent drives and 5 receivers. These are designed to interface between data terminal equipment and data communication equipment as designed by EIA-232-D.

Features

- Meets standard EIA-232-D (Revision of RS-232-C)
- Designed to Support Data Rate up to 120kbps
- Drivers
 - Current Limited Output 10 mA Typical
 - Power-off Output Impedance 300 Ω Min
 - Slew Rate Control by Load Capacitor
 - Flexible Supply Voltage Range
 - Input Compatible with Most TTL and DTL Circuits
- Receivers
 - Input Resistance 3 kΩ to 7 kΩ
 - Input Signal Range ± 30 V
 - Built-in Input Hysteresis (Double Threshold)
- 20 DIP/SO20: MS-001AD (IN75232N) / MS-013AC (IN75232D)

Block Diagram

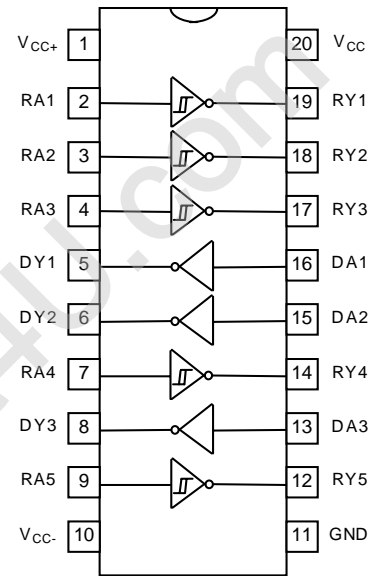

IN75232N, IN75232D

Pin Description

Name	Pin No	Function	Name	Pin No	Function
V _{CC+}	1	Driver Section Supply +	V _{CC-}	10	Driver Section Supply -
DA1	16		DY1	5	
DA2	15		DY2	6	Driver Output
DA3	13	Driver Input	DY3	8	
V _{CC}	20	Receiver Section Supply	GND	11	Ground
RA1	2		RY1	19	
RA2	3		RY2	18	
RA3	4	Receiver Input	RY3	17	Receiver Output
RA4	7		RY4	14	
RA5	9		RY5	12	

Absolute Maximum Ratings

Symbol	Parameter	Rating	Unit
V _{CC+}	Supply Voltage	15	V
V _{CC-}	Supply Voltage	-15	V
V _{CC}	Supply Voltage	10	V
VI (Driver)	Input Voltage	-15 ÷ +7	V
VI (Receiver)	Input Voltage	± 30	V
VO (Driver)	Output Voltage	-15 ÷ +15	V
PT	Continuous Power Dissipation (Below 25 °C)	1.0	W
T _{STG}	Storage Temperature	-65 ÷ +175	°C
Top	Operating Temperature	0 ÷ +75	°C

Schematic

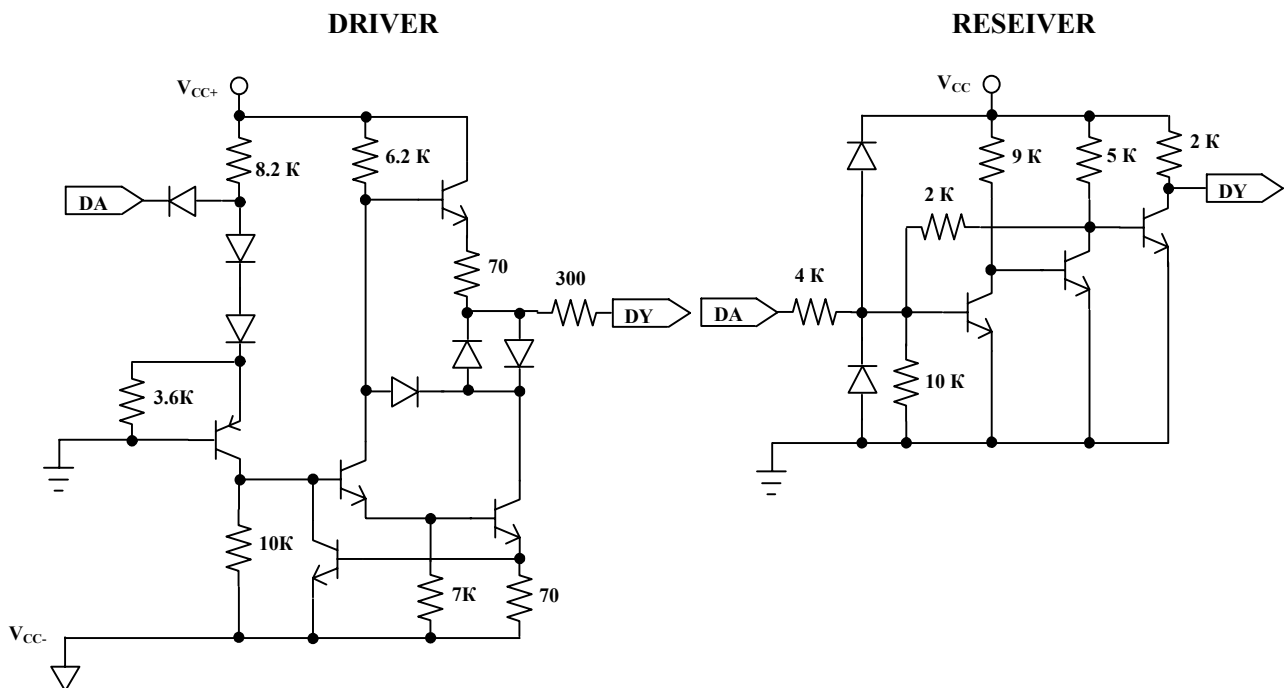

Electrical Characteristics

Supply Current

$V_{CC} = 5V, T_A = 25\text{ }^{\circ}C$

Symbol	Parameter	Test Conditions		Min	Max	Unit
I_{CC+}	Supply Current from V_{CC+}	$V_{CC+} = 9\text{ V}$	$V_{IN} = 1.9V$		15	mA
		No Load	$V_{IN} = 0.8V$		4.5	
		$V_{CC+} = 12\text{ V}$	$V_{IN} = 1.9V$		19	
		No Load	$V_{IN} = 0.8V$		5.5	
		$V_{CC+} = 15\text{ V}$	$V_{IN} = 1.9V$		25	
		No Load	$V_{IN} = 0.8V$		9	
I_{CC-}	Supply Current from V_{CC-}	$V_{CC-} = -9\text{ V}$	$V_{IN} = 1.9V$		-15	mA
		No Load	$V_{IN} = 0.8V$		-3.2	
		$V_{CC-} = -12\text{ V}$	$V_{IN} = 1.9V$		-19	
		No Load	$V_{IN} = 0.8V$		-3.2	
		$V_{CC-} = -15\text{ V}$	$V_{IN} = 1.9V$		-25	
		No Load	$V_{IN} = 0.8V$		-3.2	
I_{CC}	Supply Current from V_{CC}	$V_{CC} = 5\text{ V}$	$V_{IN} = 5.0V$		30	mA

Driver Section

Symbol	Parameter	Test Conditions		Min	Max	Unit
V_{IH}	High Level	$V_{CC+} = 9\text{ V}$		1.9		V
	Input Voltage	$V_{CC-} = -9\text{ V}$				
V_{IL}	Low Level				0.8	V
	Input Voltage					
V_{OH}	High Level	$V_{IL} = 0.8V$	$V_{CC+} = 9\text{ V}$	6		V
	Output Voltage	$RL = 3\text{ k}\Omega$	$V_{CC-} = -9\text{ V}$			
				$V_{CC+} = 13.2\text{ V}$	9	
			$V_{CC-} = -13.2\text{ V}$			
V_{OL}	Low Level	$V_{IH} = 1.9V$	$V_{CC+} = 9\text{ V}$		-6	V
	Output Voltage	$RL = 3\text{ k}\Omega$	$V_{CC-} = -9\text{ V}$			
				$V_{CC+} = 13.2\text{ V}$	-9	
			$V_{CC-} = -13.2\text{ V}$			
I_{IH}	High Level	$V_I = 5V$			10	μA
	Input Current					
I_{IL}	Low Level	$V_I = 0$			-1.6	mA
	Input Current					
$I_{OS(H)}$	Short Circuit	$V_I = 0.8V$		-6	-12	mA
	Output Current at High Level	$V_O = 0$				
$I_{OS(L)}$	Short Circuit	$V_I = 1.9V$		6	12	mA
	Output Current at Low Level	$V_O = 0$				
R_O	Output Resistance, Power Off	$V_{CC+} = 0, V_{CC-} = 0$ $V_O = -2V\text{ to }2V$		300		Ω

Driver Switching Characteristic $V_{CC+} = 9V, V_{CC-} = -9V, T_A = 25\text{ }^{\circ}\text{C}$

Symbol	Parameter	Test Conditions	Min	Max	Unit
t_{PLH}	Propagation Delay Time,	$R_L = 3\text{ k}\Omega$		500	ns
	Low-To-High-Level Output	$C_L = 15\text{ }\mu\text{F}$			
t_{PHL}	Propagation Delay Time,			175	ns
	High -To- Low -Level Output	See Figure 1			
t_{TLH}	Transition Time,			100	ns
	Low-To-High-Level Output *				
t_{THL}	Transition Time,			75	ns
	High -To- Low -Level Output*				
t_{TLH}	Transition Time,	$R_L = 3\text{ k}\Omega$ to $7\text{ k}\Omega$	2.5		μs
	Low-To-High-Level Output**	$C_L = 2500\text{ }\rho\text{F}$	(tip)		
t_{THL}	Transition Time,		3.0		μs
	High-To-Low -Level Output**	See Figure 1	(tip)		

*- Measured between 10 % and 90 % Points of Output Waveform

**- Measured between +3V and -3V Points on the Output Waveform (EIA-232-D Condition)

Receiver Section

Symbol	Parameter	Test Conditions	Min	Max	Unit
VT+	Positive-Going		1.75	2.25	V
	Threshold Voltage				
VT-	Negative-Going		0.75	1.25	V
	Threshold Voltage				
V_{OH}	High Level Output	$V_I = 0.75V, I_{OL} = -0.5mA$	2.6	5	V
	Voltage	Input Open,	2.6	5	
		$I_{OL} = -0.5\text{ mA}$			
V_{OL}	Low Level Output Voltage	$V_I = 3V, I_{OL} = 10\text{ mA}$		0.45	V
I_{IH}	High-Level Input Current	$V_I = 25V$	3.6	8.3	mA
		$V_I = 3V$	0.43		
I_{IL}	Low-Level Input Current	$V_I = -25V$	-3.6	-8.3	mA
		$V_I = -3V$	-0.43		
I_{OS}	Short-Circuit		-3		mA
	Output Current		(tip)		

Receiver Switching Characteristic $V_{CC} = 5V$

Symbol	Parameter	Test Conditions	Min	Max	Unit
t_{PLH}	Propagation Delay Time,	$C_L = 15\text{ }\rho\text{F}$		150	ns
	Low-To-High-Level Output	$R_L = 3.9\text{ k}\Omega$			
t_{PHL}	Propagation Delay Time,	$C_L = 15\text{ }\rho\text{F}$		50	ns
	High -To- Low -Level Output	$R_L = 390\text{ k}\Omega$			
t_{TLH}	Transition Time,	$C_L = 15\text{ }\rho\text{F}$		175	ns
	Low-To-High-Level Output	$R_L = 3.9\text{ k}\Omega$			
t_{THL}	Transition Time,	$C_L = 15\text{ }\rho\text{F}$		20	ns
	High -To- Low -Level Output	$R_L = 390\text{ k}\Omega$			

Parameter Measurement Information

DRIVER

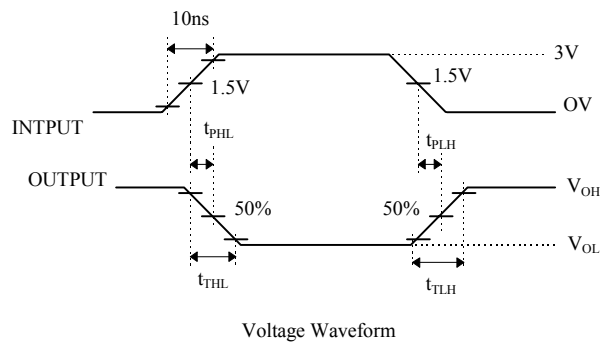
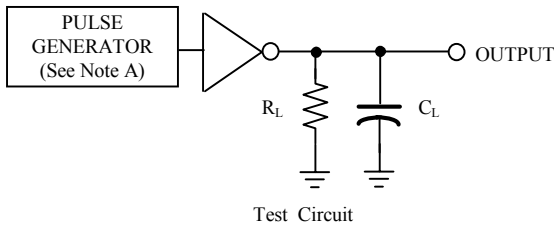

RESEIVER

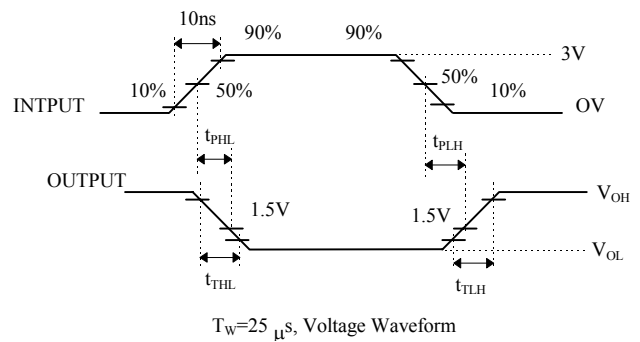
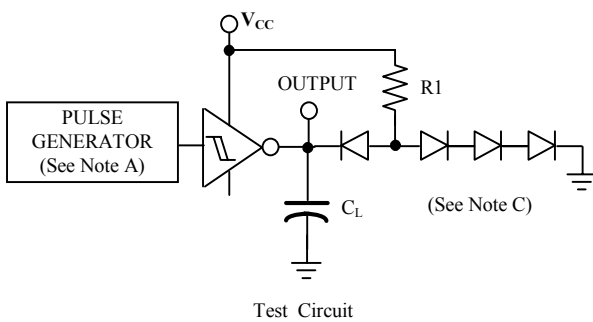

- Note A. The pulse generator has the following characteristics. $f = 200 \text{ KHz}$, $Z_0 = 50 \Omega$
- B. C included probe and jig capacitance.
- C. All diodes are 1N3064 or equivalent.

Fig1. Propagation and Transition Times

Typical Application

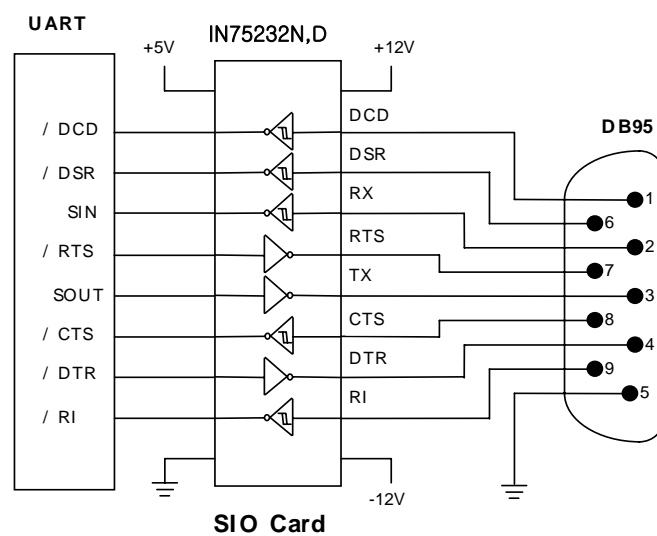

**N SUFFIX PLASTIC DIP
(MS - 001AD)**

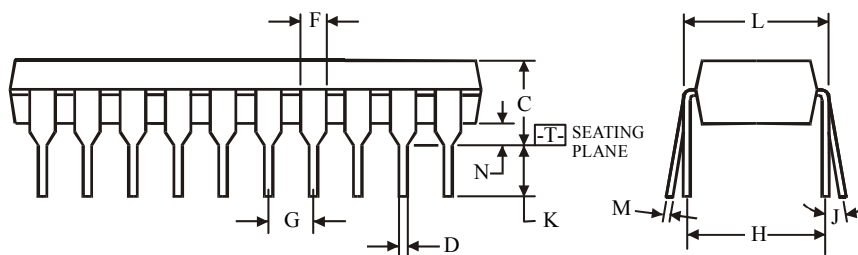
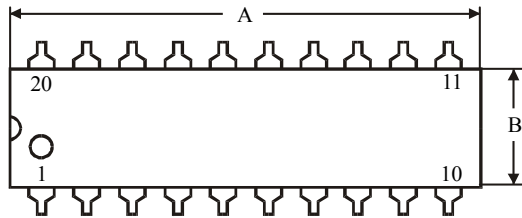
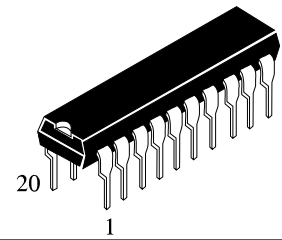

$\oplus 0.25 (0.010) \text{ (M) T}$

NOTES:

- Dimensions "A", "B" do not include mold flash or protrusions.
Maximum mold flash or protrusions 0.25 mm (0.010) per side.

Symbol	Dimension, mm	
	MIN	MAX
A	24.89	26.92
B	6.1	7.11
C		5.33
D	0.36	0.56
F	1.14	1.78
G	2.54	
H	7.62	
J	0°	10°
K	2.92	3.81
L	7.62	8.26
M	0.2	0.36
N	0.38	

**D SUFFIX SOIC
(MS - 013AC)**

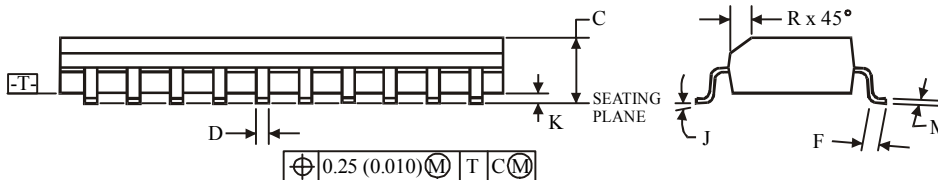
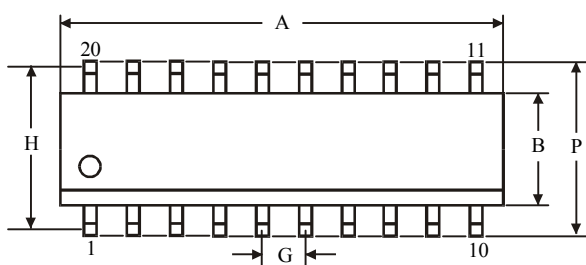
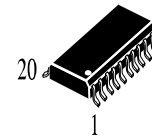

$\oplus 0.25 (0.010) \text{ (M) T C (M)}$

NOTES:

- Dimensions A and B do not include mold flash or protrusion.
- Maximum mold flash or protrusion 0.15 mm (0.006) per side for A; for B - 0.25 mm (0.010) per side.

Symbol	Dimension, mm	
	MIN	MAX
A	12.6	13
B	7.4	7.6
C	2.35	2.65
D	0.33	0.51
F	0.4	1.27
G	1.27	
H	9.53	
J	0°	8°
K	0.1	0.3
M	0.23	0.32
P	10	10.65
R	0.25	0.75