

INA225-Q1 Automotive-Grade, 36-V Programmable-Gain, Voltage-Output, Bidirectional, Zero-Drift, High-Speed Current-Shunt Monitor

1 Features

- AEC-Q100 Qualified:
 - Temperature Grade 1: -40°C to $+125^{\circ}\text{C}$
 - HBM ESD Classification 2
 - CDM ESD Classification C4B
- Wide Common-Mode Range: 0 V to 36 V
- Offset Voltage: $\pm 150\ \mu\text{V}$ (Max, All Gains)
- Offset Voltage Drift: $0.5\ \mu\text{V}/^{\circ}\text{C}$ (Max)
- Gain Accuracy, Over Temperature (Max):
 - 25 V/V, 50 V/V: $\pm 0.15\%$
 - 100 V/V: $\pm 0.2\%$
 - 200 V/V: $\pm 0.3\%$
 - 10-ppm/ $^{\circ}\text{C}$ Gain Drift
- Bandwidth: 250 kHz (Gain = 25 V/V)
- Programmable Gains:
 - G1 = 25 V/V
 - G2 = 50 V/V
 - G3 = 100 V/V
 - G4 = 200 V/V
- Quiescent Current: 350 μA (Max)
- Package: VSSOP-8

2 Applications

- Automotive Lighting
- Body Control Module
- Motor Control
- Valve Control
- Cluster
- Central Control Module

3 Description

The INA225-Q1 is a voltage-output, current-sense amplifier that senses drops across current-sensing resistors at common-mode voltages that vary from 0 V to 36 V, independent of the supply voltage. The device is a bidirectional, current-shunt monitor that allows an external reference to be used to measure current flowing in both directions across a current-sensing resistor.

Four discrete gain levels are selectable using the two gain-select terminals (GS0 and GS1) to program gains of 25 V/V, 50 V/V, 100 V/V, and 200 V/V. The low-offset, zero-drift architecture and precision gain values enable current-sensing with maximum drops across the shunt as low as 10 mV of full-scale, while maintaining very high accuracy measurements over the entire operating temperature range.

The device operates from a single +2.7-V to +36-V power supply, drawing a maximum of 350 μA of supply current. The device is specified over the extended operating temperature range of -40°C to $+125^{\circ}\text{C}$, and is offered in a VSSOP-8 package.

Device Information⁽¹⁾

PART NUMBER	PACKAGE	BODY SIZE (NOM)
INA225-Q1	VSSOP (8)	3.00 mm x 3.00 mm

(1) For all available packages, see the package option addendum at the end of the data sheet.

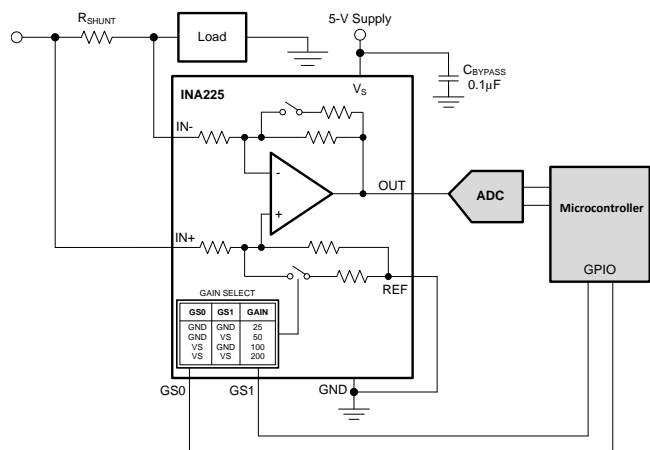

Table of Contents

1 Features	1	7.3 Feature Description	13
2 Applications	1	7.4 Device Functional Modes	16
3 Description	1	8 Applications and Implementation	19
4 Revision History	2	8.1 Application Information	19
5 Pin Configuration and Functions	3	8.2 Typical Applications	19
6 Specifications	4	9 Power Supply Recommendations	25
6.1 Absolute Maximum Ratings	4	10 Layout	25
6.2 ESD Ratings	4	10.1 Layout Guidelines	25
6.3 Recommended Operating Conditions	4	10.2 Layout Example	25
6.4 Thermal Information	4	11 Device and Documentation Support	26
6.5 Electrical Characteristics	5	11.1 Related Documentation	26
6.6 Typical Characteristics	7	11.2 Trademarks	26
7 Detailed Description	13	11.3 Electrostatic Discharge Caution	26
7.1 Overview	13	11.4 Glossary	26
7.2 Functional Block Diagram	13	12 Mechanical, Packaging, and Orderable Information	26

4 Revision History

DATE	REVISION	NOTES
February 2015	*	Initial release.

5 Pin Configuration and Functions

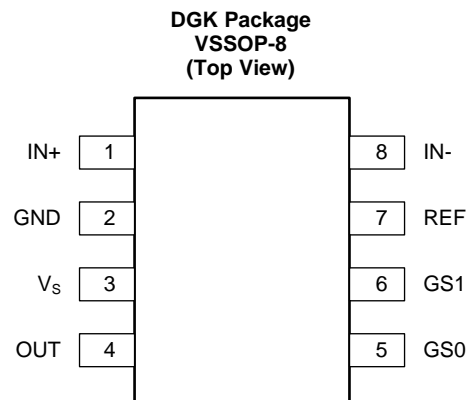

Pin Functions

PIN		I/O	DESCRIPTION
NO.	NAME		
1	IN+	Analog input	Connect to supply side of shunt resistor.
2	GND	Analog	Ground
3	V _S	Analog	Power supply, 2.7 V to 36 V
4	OUT	Analog output	Output voltage
5	GS0	Digital input	Gain select. Connect to V _S or GND. Table 3 lists terminal settings and the corresponding gain value.
6	GS1	Digital input	Gain select. Connect to V _S or GND. Table 3 lists terminal settings and the corresponding gain value.
7	REF	Analog input	Reference voltage, 0 V to V _S
8	IN-	Analog input	Connect to load side of shunt resistor.

6 Specifications

6.1 Absolute Maximum Ratings⁽¹⁾

Over operating free-air temperature range, unless otherwise noted.

		MIN	MAX	UNIT
Supply voltage			+40	V
Analog inputs, V_{IN+} , V_{IN-} ⁽²⁾	Differential ($V_{IN+} - V_{IN-}$)	-40	+40	V
	Common-mode ⁽³⁾	GND - 0.3	+40	V
REF, GS0, and GS1 inputs		GND - 0.3	(V_S) + 0.3	V
Output		GND - 0.3	(V_S) + 0.3	V
Temperature	Operating, T_A	-55	+150	°C
	Junction, T_J		+150	°C
	Storage, T_{stg}	-65	+150	°C

- (1) Stresses beyond those listed under *Absolute Maximum Ratings* may cause permanent damage to the device. These are stress ratings only, which do not imply functional operation of the device at these or any other conditions beyond those indicated under *Recommended Operating Conditions*. Exposure to absolute-maximum-rated conditions for extended periods may affect device reliability.
- (2) V_{IN+} and V_{IN-} are the voltages at the IN+ and IN- terminals, respectively.
- (3) Input voltage at any terminal may exceed the voltage shown if the current at that terminal is limited to 5 mA.

6.2 ESD Ratings

		VALUE	UNIT
$V_{(ESD)}$ Electrostatic discharge	Human-body model (HBM), per AEC Q100-002 ⁽¹⁾	±2500	V
	Charged-device model (CDM), per AEC Q100-011	±1000	

- (1) AEC Q100-002 indicates that HBM stressing shall be in accordance with the ANSI/ESDA/JEDEC JS-001 specification.

6.3 Recommended Operating Conditions

Over operating free-air temperature range, unless otherwise noted.

		MIN	NOM	MAX	UNIT
V_{CM}	Common-mode input voltage		12		V
V_S	Operating supply voltage		5		V
T_A	Operating free-air temperature	-40		+125	°C

6.4 Thermal Information

THERMAL METRIC		INA225-Q1	UNIT
		DGK (VSSOP)	
		8 PINS	
$R_{\theta JA}$	Junction-to-ambient thermal resistance	163.6	°C/W
$R_{\theta JC(top)}$	Junction-to-case (top) thermal resistance	57.7	
$R_{\theta JB}$	Junction-to-board thermal resistance	84.7	
Ψ_{JT}	Junction-to-top characterization parameter	6.5	
Ψ_{JB}	Junction-to-board characterization parameter	83.2	
$R_{\theta JC(bot)}$	Junction-to-case (bottom) thermal resistance	N/A	

6.5 Electrical Characteristics

At $T_A = +25^\circ\text{C}$, $V_{\text{SENSE}} = V_{\text{IN}+} - V_{\text{IN}-}$, $V_S = +5\text{ V}$, $V_{\text{IN}+} = 12\text{ V}$, and $V_{\text{REF}} = V_S / 2$, unless otherwise noted.

PARAMETER		CONDITIONS	MIN	TYP	MAX	UNIT
INPUT						
V_{CM}	Common-mode input range	$T_A = -40^\circ\text{C}$ to $+125^\circ\text{C}$	0		36	V
CMR	Common-mode rejection	$V_{\text{IN}+} = 0\text{ V}$ to $+36\text{ V}$, $V_{\text{SENSE}} = 0\text{ mV}$, $T_A = -40^\circ\text{C}$ to $+125^\circ\text{C}$	95	105		dB
V_{OS}	Offset voltage, RTI ⁽¹⁾	$V_{\text{SENSE}} = 0\text{ mV}$		± 75	± 150	μV
dV_{OS}/dT	RTI vs temperature	$T_A = -40^\circ\text{C}$ to $+125^\circ\text{C}$		0.2	0.5	$\mu\text{V}/^\circ\text{C}$
PSRR	Power-supply rejection ratio	$V_{\text{SENSE}} = 0\text{ mV}$, $V_{\text{REF}} = 2.5\text{ V}$, $V_S = 2.7\text{ V}$ to 36 V		± 0.1	± 1	$\mu\text{V}/\text{V}$
I_B	Input bias current	$V_{\text{SENSE}} = 0\text{ mV}$	55	72	85	μA
I_{OS}	Input offset current	$V_{\text{SENSE}} = 0\text{ mV}$		± 0.5		μA
V_{REF}	Reference input range	$T_A = -40^\circ\text{C}$ to $+125^\circ\text{C}$	0		V_S	V
OUTPUT						
G	Gain		25, 50, 100, 200			V/V
E_G	Gain error	Gain = 25 V/V and 50 V/V, $V_{\text{OUT}} = 0.5\text{ V}$ to $V_S - 0.5\text{ V}$, $T_A = -40^\circ\text{C}$ to $+125^\circ\text{C}$		$\pm 0.05\%$	$\pm 0.15\%$	
		Gain = 100 V/V, $V_{\text{OUT}} = 0.5\text{ V}$ to $V_S - 0.5\text{ V}$, $T_A = -40^\circ\text{C}$ to $+125^\circ\text{C}$		$\pm 0.1\%$	$\pm 0.2\%$	
		Gain = 200 V/V, $V_{\text{OUT}} = 0.5\text{ V}$ to $V_S - 0.5\text{ V}$, $T_A = -40^\circ\text{C}$ to $+125^\circ\text{C}$		$\pm 0.1\%$	$\pm 0.3\%$	
	Gain error vs temperature	G = 25 V/V, 50 V/V, 100 V/V, $T_A = -40^\circ\text{C}$ to $+125^\circ\text{C}$		3	10	ppm/ $^\circ\text{C}$
		G = 200 V/V, $T_A = -40^\circ\text{C}$ to $+125^\circ\text{C}$		5	15	
	Nonlinearity error	$V_{\text{OUT}} = 0.5\text{ V}$ to $V_S - 0.5\text{ V}$		$\pm 0.01\%$		
	Maximum capacitive load	No sustained oscillation		1		nF
VOLTAGE OUTPUT⁽²⁾						
	Swing to V_S power-supply rail	$R_L = 10\text{ k}\Omega$ to GND, $T_A = -40^\circ\text{C}$ to $+125^\circ\text{C}$		$V_S - 0.05$	$V_S - 0.2$	V
	Swing to GND ⁽³⁾	$V_{\text{REF}} = V_S / 2$, all gains, $R_L = 10\text{ k}\Omega$ to GND, $T_A = -40^\circ\text{C}$ to $+125^\circ\text{C}$		$V_{\text{GND}} + 5$	$V_{\text{GND}} + 10$	mV
		$V_{\text{REF}} = \text{GND}$, gain = 25 V/V, $R_L = 10\text{ k}\Omega$ to GND, $T_A = -40^\circ\text{C}$ to $+125^\circ\text{C}$		$V_{\text{GND}} + 7$		mV
		$V_{\text{REF}} = \text{GND}$, gain = 50 V/V, $R_L = 10\text{ k}\Omega$ to GND, $T_A = -40^\circ\text{C}$ to $+125^\circ\text{C}$		$V_{\text{GND}} + 15$		mV
		$V_{\text{REF}} = \text{GND}$, gain = 100 V/V, $R_L = 10\text{ k}\Omega$ to GND, $T_A = -40^\circ\text{C}$ to $+125^\circ\text{C}$		$V_{\text{GND}} + 30$		mV
		$V_{\text{REF}} = \text{GND}$, gain = 200 V/V, $R_L = 10\text{ k}\Omega$ to GND, $T_A = -40^\circ\text{C}$ to $+125^\circ\text{C}$		$V_{\text{GND}} + 60$		mV
FREQUENCY RESPONSE						
BW	Bandwidth	Gain = 25 V/V, $C_{\text{LOAD}} = 10\text{ pF}$		250		kHz
		Gain = 50 V/V, $C_{\text{LOAD}} = 10\text{ pF}$		200		kHz
		Gain = 100 V/V, $C_{\text{LOAD}} = 10\text{ pF}$		125		kHz
		Gain = 200 V/V, $C_{\text{LOAD}} = 10\text{ pF}$		70		kHz
SR	Slew rate			0.4		V/ μs
NOISE, RTI⁽¹⁾						
	Voltage noise density			50		nV/ $\sqrt{\text{Hz}}$

(1) RTI = referred-to-input.

(2) See Typical Characteristic curve, *Output Voltage Swing vs Output Current* (Figure 10).

(3) See Typical Characteristic curve, *Unidirectional Output Voltage Swing vs. Temperature* (Figure 14)

Electrical Characteristics (continued)

 At $T_A = +25^\circ\text{C}$, $V_{\text{SENSE}} = V_{\text{IN}+} - V_{\text{IN}-}$, $V_S = +5\text{ V}$, $V_{\text{IN}+} = 12\text{ V}$, and $V_{\text{REF}} = V_S / 2$, unless otherwise noted.

PARAMETER		CONDITIONS	MIN	TYP	MAX	UNIT
DIGITAL INPUT						
C_i	Input capacitance			3		pF
	Leakage input current	$0 \leq V_{\text{IN}} \leq V_S$		1	2	μA
V_{IL}	Low-level input logic level		0		0.6	V
V_{IH}	High-level input logic level		2		V_S	V
POWER SUPPLY						
V_S	Operating voltage range	$T_A = -40^\circ\text{C}$ to $+125^\circ\text{C}$	+2.7		+36	V
I_Q	Quiescent current	$V_{\text{SENSE}} = 0\text{ mV}$		300	350	μA
	I_Q over temperature	$T_A = -40^\circ\text{C}$ to $+125^\circ\text{C}$			375	μA
TEMPERATURE RANGE						
	Specified range		-40		+125	$^\circ\text{C}$
	Operating range		-55		+150	$^\circ\text{C}$

6.6 Typical Characteristics

At $T_A = +25^\circ\text{C}$, $V_S = +5\text{ V}$, $V_{IN+} = 12\text{ V}$, and $V_{REF} = V_S / 2$, unless otherwise noted.

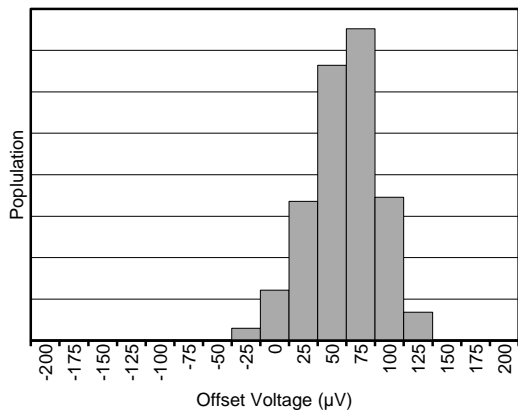

Figure 1. Input Offset Voltage Production Distribution

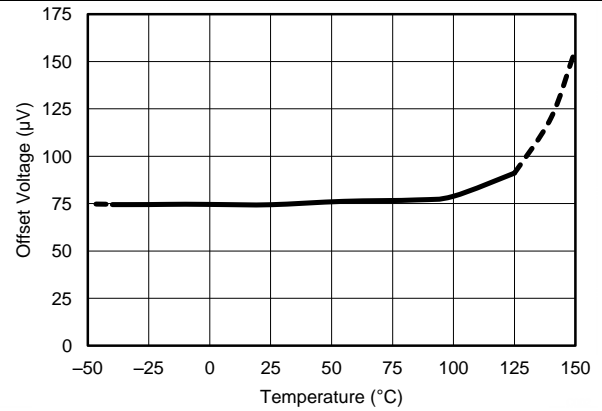

Figure 2. Input Offset Voltage vs Temperature

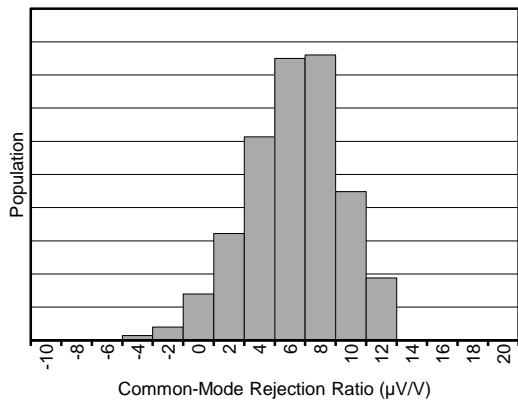

Figure 3. Common-Mode Rejection Production Distribution

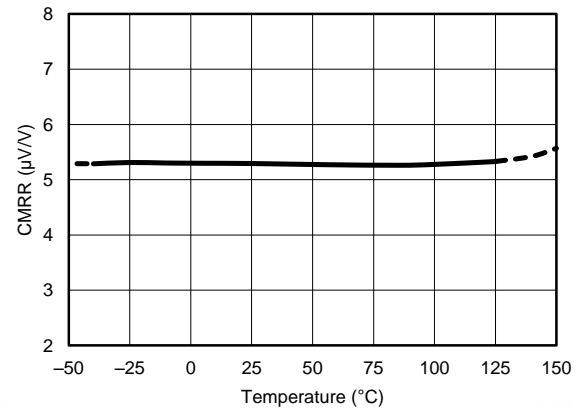

Figure 4. Common-Mode Rejection Ratio vs Temperature

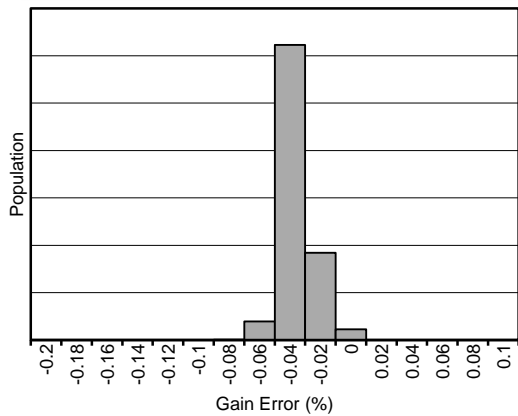

Figure 5. Gain Error Production Distribution (Gain = 25 V/V)

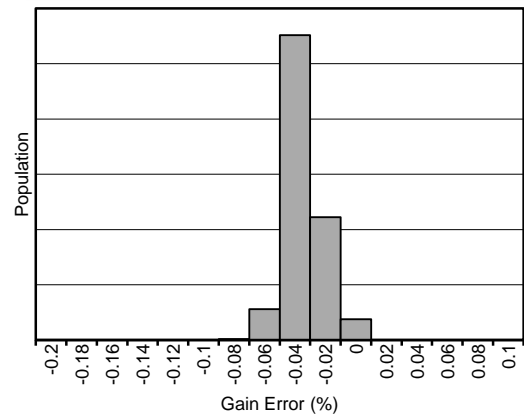

Figure 6. Gain Error Production Distribution (Gain = 50 V/V)

Typical Characteristics (continued)

At $T_A = +25^\circ\text{C}$, $V_S = +5\text{ V}$, $V_{IN+} = 12\text{ V}$, and $V_{REF} = V_S / 2$, unless otherwise noted.

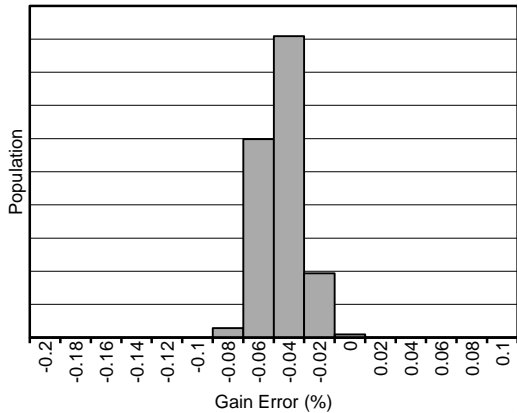

Figure 7. Gain Error Production Distribution (Gain = 100 V/V)

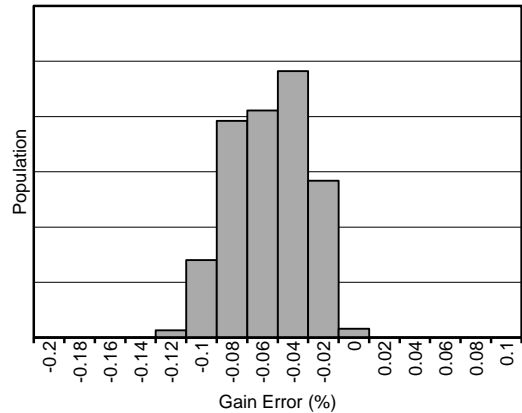

Figure 8. Gain Error Production Distribution (Gain = 200 V/V)

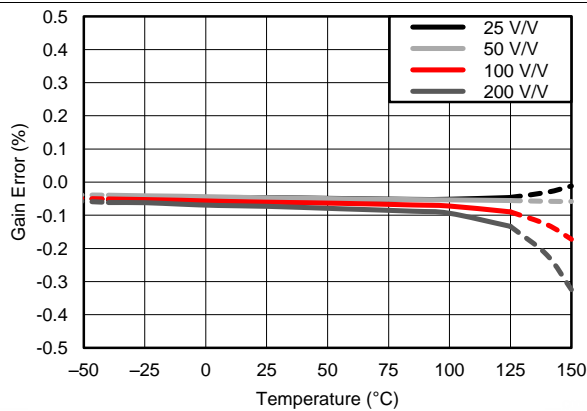

Figure 9. Gain Error vs Temperature

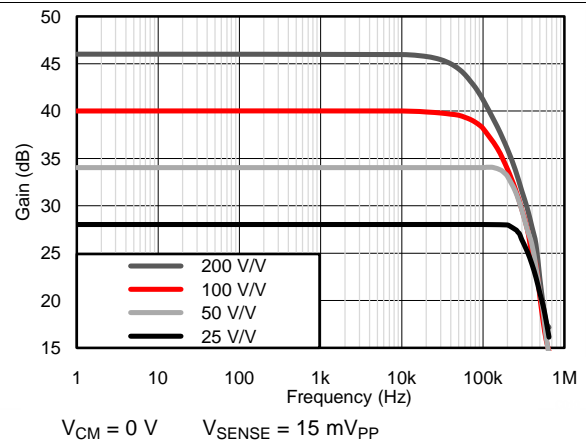

Figure 10. Gain vs Frequency

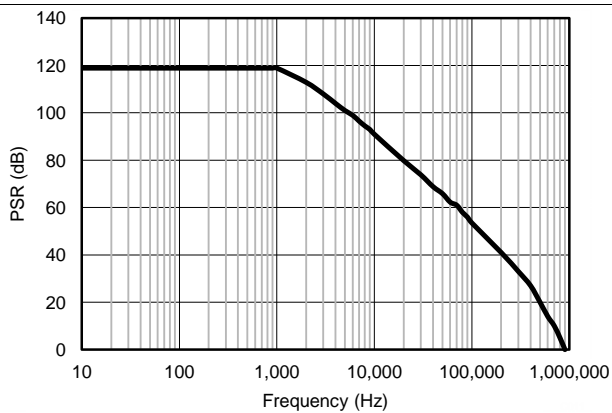

Figure 11. Power-Supply Rejection Ratio vs Frequency

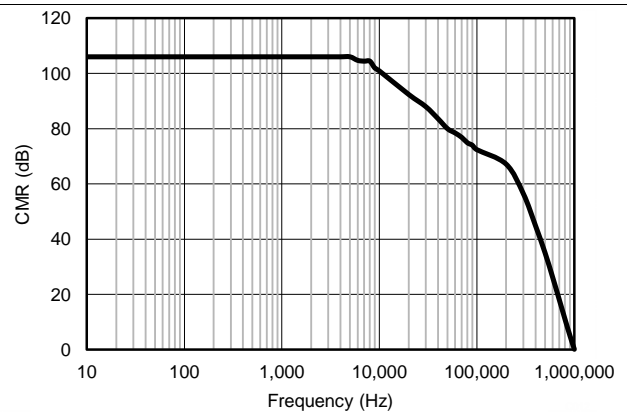

Figure 12. Common-Mode Rejection Ratio vs Frequency

Typical Characteristics (continued)

At $T_A = +25^\circ\text{C}$, $V_S = +5\text{ V}$, $V_{IN+} = 12\text{ V}$, and $V_{REF} = V_S / 2$, unless otherwise noted.

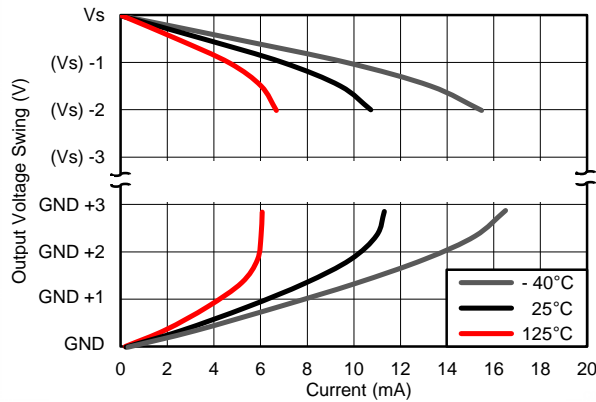
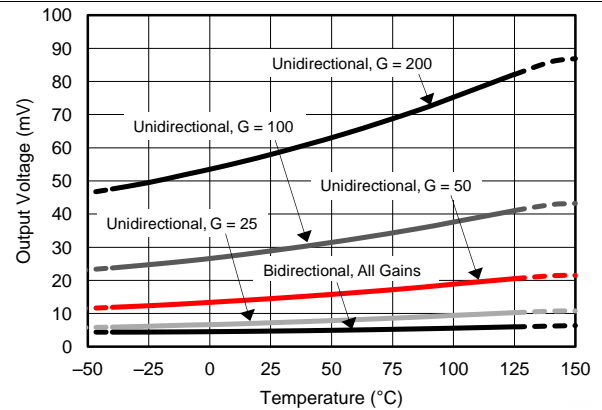

Figure 13. Output Voltage Swing vs Output Current



Unidirectional, REF = GND Bidirectional, REF > GND

Figure 14. Unidirectional Output Voltage Swing vs. Temperature

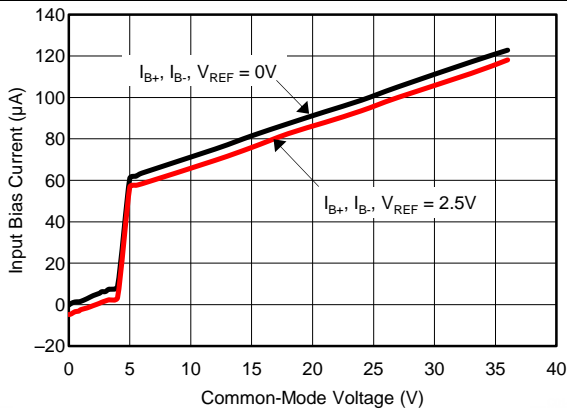

Figure 15. Input Bias Current vs Common-Mode Voltage (Supply Voltage = +5 V)

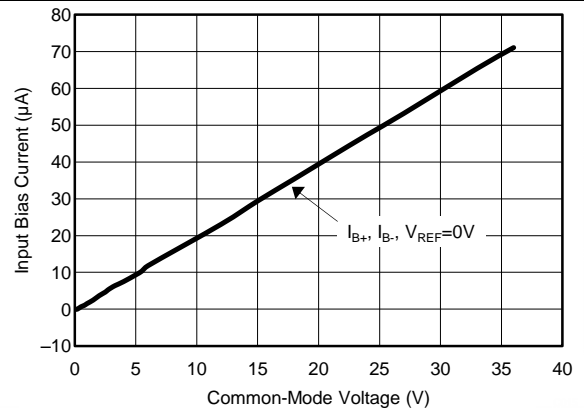

Figure 16. Input Bias Current vs Common-Mode Voltage (Supply Voltage = 0 V, Shutdown)

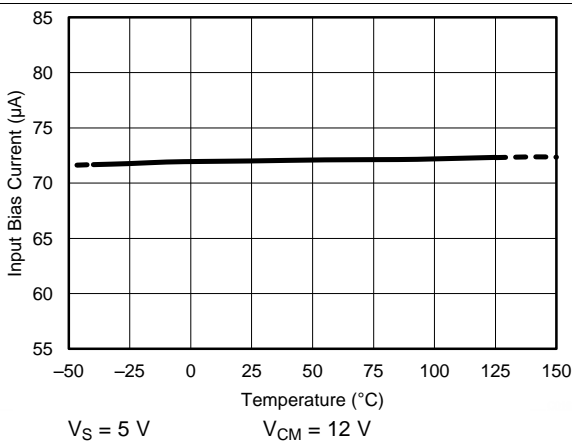

Figure 17. Input Bias Current vs Temperature

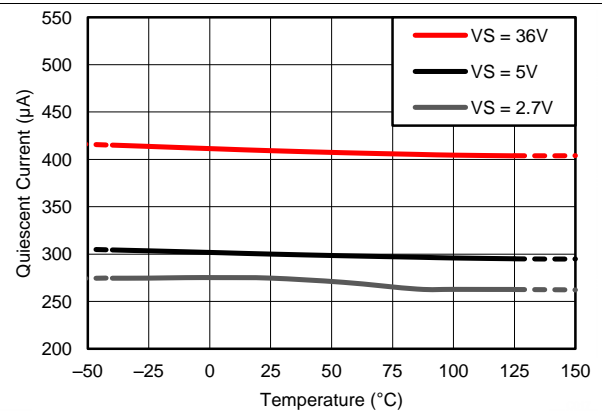

Figure 18. Quiescent Current vs Temperature

Typical Characteristics (continued)

 At $T_A = +25^\circ\text{C}$, $V_S = +5\text{ V}$, $V_{IN+} = 12\text{ V}$, and $V_{REF} = V_S / 2$, unless otherwise noted.

Figure 19. Quiescent Current vs Supply Voltage

 $V_S = \pm 2.5\text{ V}$ $V_{REF} = 0\text{ V}$ $V_{SENSE} = 0\text{ mV}$, Shorted

Figure 20. Input-Referred Voltage Noise vs Frequency

 $V_S = \pm 2.5\text{ V}$ $V_{CM} = 0\text{ V}$ $V_{SENSE} = 0\text{ mV}$, Shorted

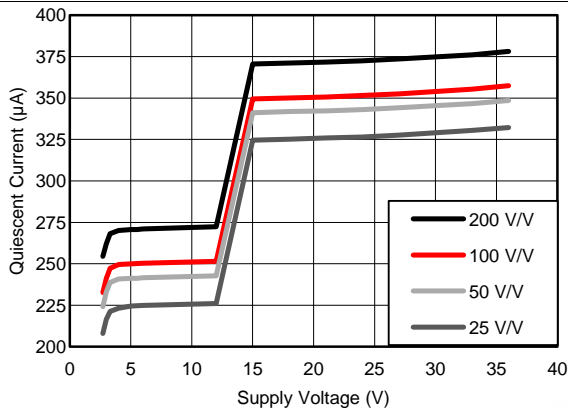
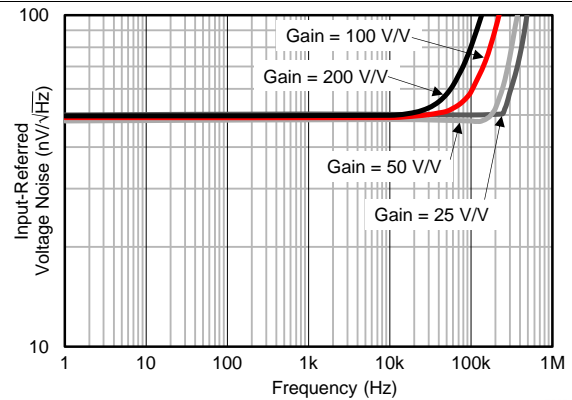
Figure 21. 0.1-Hz to 10-Hz Voltage Noise (Referred-to-Input)

Figure 22. Step Response (Gain = 25 V/V, 2- V_{PP} Output Step)

Figure 23. Step Response (Gain = 50 V/V, 2- V_{PP} Output Step)

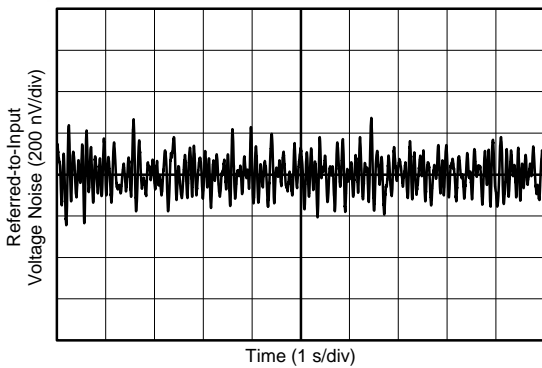
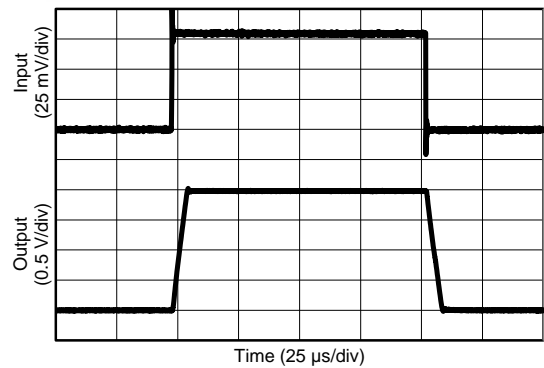
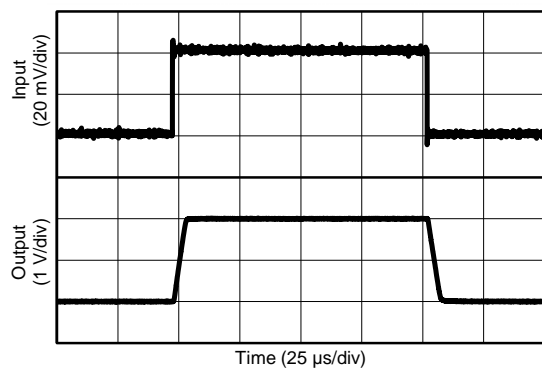
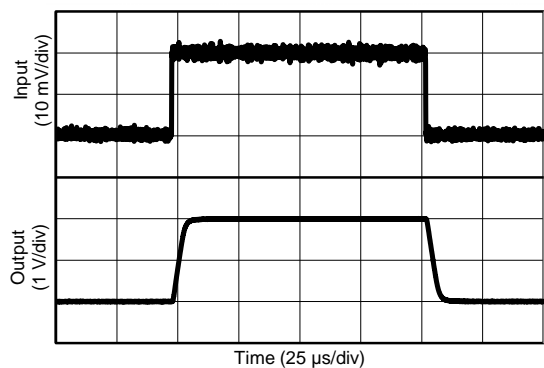
Figure 24. Step Response (Gain = 100 V/V, 2- V_{PP} Output Step)

Typical Characteristics (continued)

At $T_A = +25^\circ\text{C}$, $V_S = +5\text{ V}$, $V_{IN+} = 12\text{ V}$, and $V_{REF} = V_S / 2$, unless otherwise noted.

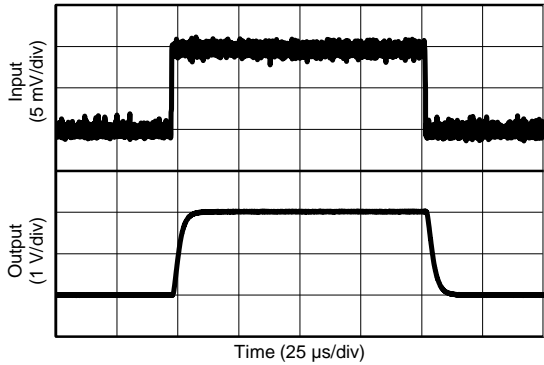
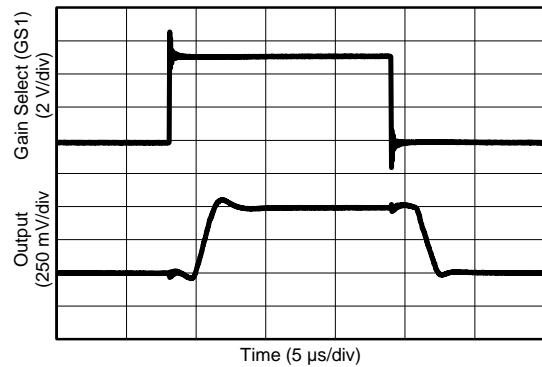
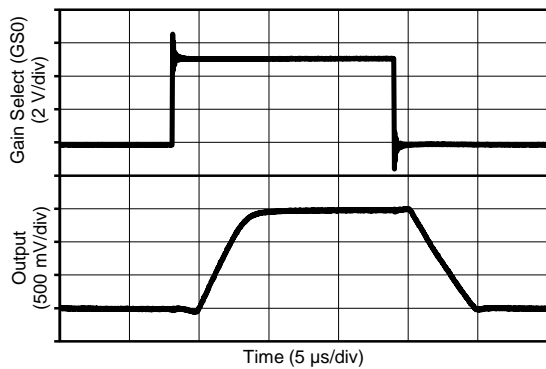

Figure 25. Step Response
(Gain = 200 V/V, 2-V_{PP} Output Step)



$V_{DIFF} = 20\text{ mV}$ V_{OUT} at 25-V/V Gain = 500 mV
 V_{OUT} at 50-V/V Gain = 1 V

Figure 26. Gain Change Output Response
(Gain = 25 V/V to 50 V/V)



$V_{DIFF} = 20\text{ mV}$ V_{OUT} at 25-V/V Gain = 500 mV
 V_{OUT} at 100-V/V Gain = 2 V

Figure 27. Gain Change Output Response
(Gain = 25 V/V to 100 V/V)

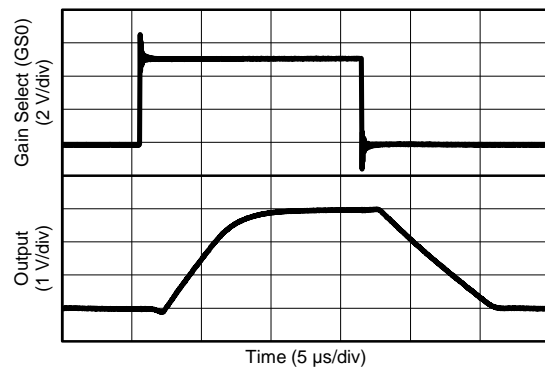

$V_{DIFF} = 20\text{ mV}$ V_{OUT} at 50-V/V Gain = 1 V
 V_{OUT} at 200-V/V Gain = 4 V

Figure 28. Gain Change Output Response
(Gain = 50 V/V to 200 V/V)

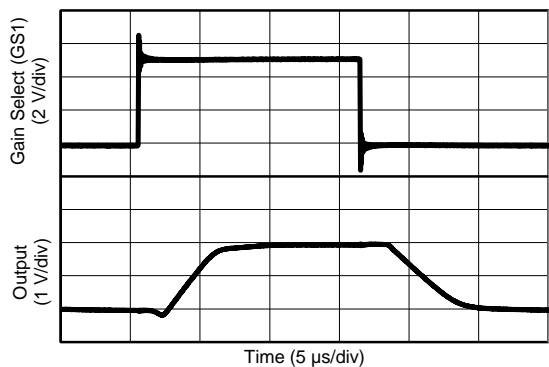

$V_{DIFF} = 20\text{ mV}$ V_{OUT} at 100-V/V Gain = 2 V
 V_{OUT} at 200-V/V Gain = 4 V

Figure 29. Gain Change Output Response
(Gain = 100 V/V to 200 V/V)

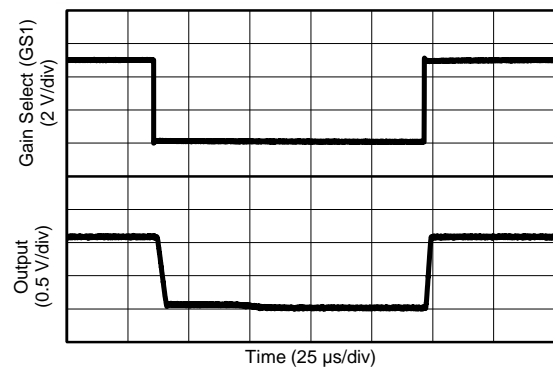

Figure 30. Gain Change Output Response From Saturation
(Gain = 50 V/V to 25 V/V)

Typical Characteristics (continued)

At $T_A = +25^\circ\text{C}$, $V_S = +5\text{ V}$, $V_{IN+} = 12\text{ V}$, and $V_{REF} = V_S / 2$, unless otherwise noted.

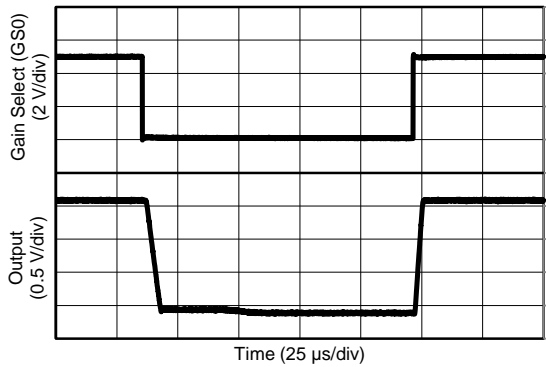

Figure 31. Gain Change Output Response From Saturation (Gain = 100 V/V to 25 V/V)

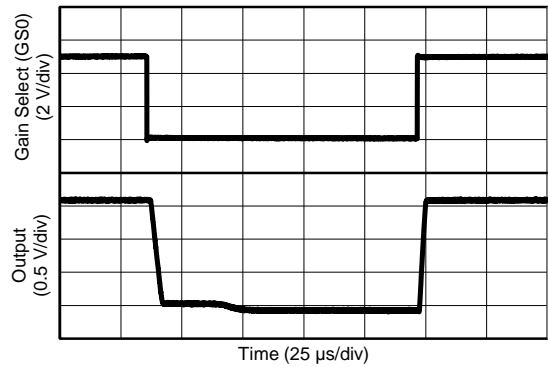

Figure 32. Gain Change Output Response From Saturation (Gain = 200 V/V to 50 V/V)

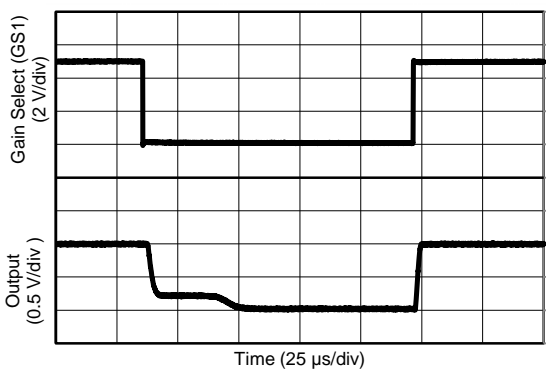

Figure 33. Gain Change Output Response From Saturation (Gain = 200 V/V to 100 V/V)

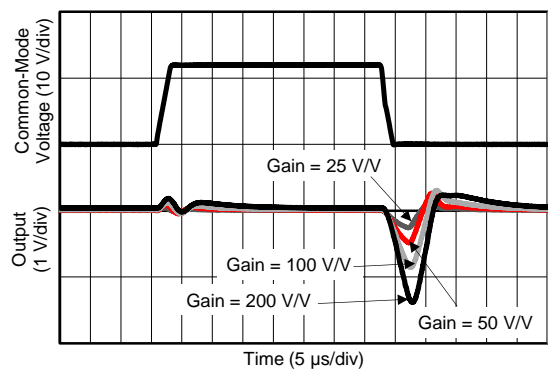

Figure 34. Common-Mode Voltage Transient Response

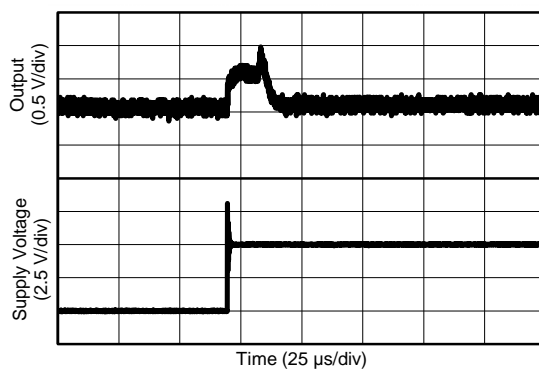

Figure 35. Start-Up Response

7 Detailed Description

7.1 Overview

The INA225-Q1 is a 36-V, common-mode, zero-drift topology, current-sensing amplifier. This device features a significantly higher signal bandwidth than most comparable precision, current-sensing amplifiers, reaching up to 125 kHz at a gain of 100 V/V. A very useful feature present in the device is the built-in programmable gain selection. To increase design flexibility with the device, a programmable gain feature is added that allows changing device gain during operation in order to accurately monitor wider dynamic input signal ranges. Four discrete gain levels (25 V/V, 50 V/V, 100 V/V, and 200 V/V) are available in the device and are selected using the two gain-select terminals, GS0 and GS1.

7.2 Functional Block Diagram

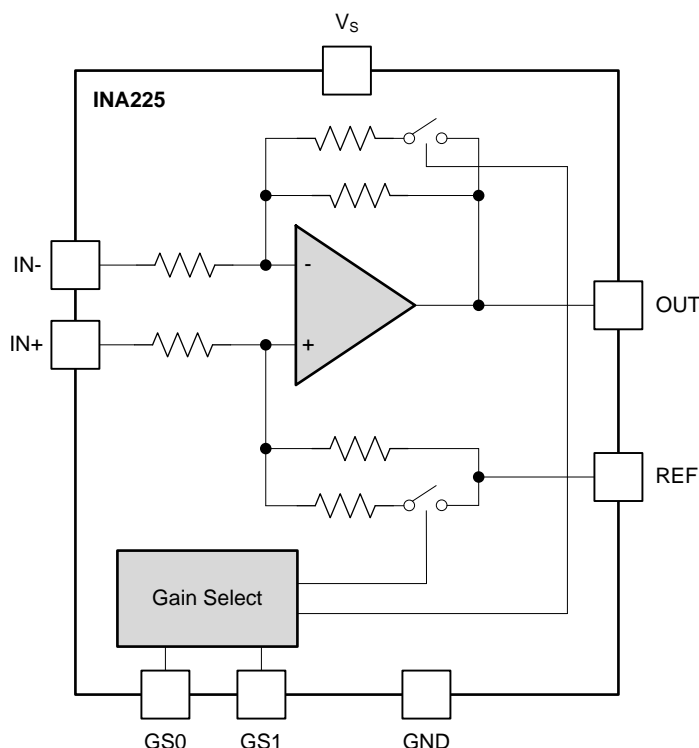

7.3 Feature Description

7.3.1 Selecting A Shunt Resistor

The device measures the differential voltage developed across a resistor when current flows through it. This resistor is commonly referred to as a *current-sensing resistor* or a *current-shunt resistor*, with each term commonly used interchangeably. The flexible design of the device allows a wide range of input signals to be measured across this current-sensing resistor.

Selecting the value of this current-sensing resistor is based primarily on two factors: the required accuracy of the current measurement and the allowable power dissipation across the resistor. The larger the voltage developed across this resistor the more accurate of a measurement that can be made because of the fixed internal amplifier errors. These fixed internal amplifier errors, which are dominated by the internal offset voltage of the device, result in a larger measurement uncertainty when the input signal gets smaller. When the input signal gets larger, the measurement uncertainty is reduced because the fixed errors become a smaller percentage of the signal being measured.

Feature Description (continued)

A system design trade-off for improving the measurement accuracy through the use of the larger input signals is the increase in the power dissipated across the current-sensing resistor. Increasing the value of the current-shunt resistor increases the differential voltage developed across the resistor when current passes through it. However, the power that is then dissipated across this component also increases. Decreasing the value of the current-shunt resistor value reduces the power dissipation requirements of the resistor, but increases the measurement errors resulting from the decreasing input signal. Finding the optimal value for the shunt resistor requires factoring both the accuracy requirement of the application and allowable power dissipation into the selection of the component. An increasing amount of very low ohmic value resistors are becoming available with values reaching down to 200 $\mu\Omega$ with power dissipations of up to 5 W, thus enabling very large currents to be accurately monitored using sensing resistors.

The maximum value for the current-sensing resistor that can be chosen is based on the full-scale current to be measured, the full-scale input range of the circuitry following the device, and the device gain selected. The minimum value for the current-sensing resistor is typically a design-based decision because maximizing the input range of the circuitry following the device is commonly preferred. Full-scale output signals that are significantly less than the full input range of the circuitry following the device output can limit the ability of the system to exercise the full dynamic range of system control based on the current measurement.

7.3.1.1 Selecting A Current-Sense Resistor Example

The example in [Table 1](#) is based on a set of application characteristics, including a 10-A full-scale current range and a 4-V full-scale output requirement. The calculations for selecting a current-sensing resistor of an appropriate value are shown in [Table 1](#).

Table 1. Calculating the Current-Sense Resistor, R_{SENSE}

PARAMETER		EQUATION	RESULT
I_{MAX}	Full-scale current		10 A
V_{OUT}	Full-scale output voltage		4 V
Gain	Gain selected	Initial selection based on default gain setting.	25 V/V
V_{DIFF}	Ideal maximum differential input voltage	$V_{DIFF} = V_{OUT} / \text{Gain}$	160 mV
R_{SHUNT}	Shunt resistor value	$R_{SHUNT} = V_{DIFF} / I_{MAX}$	16 m Ω
P_{RSENSE}	Current-sense resistor power dissipation	$R_{SENSE} \times I_{MAX}^2$	1.6 W
V_{OS} Error	Offset voltage error	$(V_{OS} / V_{DIFF}) \times 100$	0.094%

7.3.1.2 Optimizing Power Dissipation versus Measurement Accuracy

The example shown in [Table 1](#) results in a maximum current-sensing resistor value of 16 m Ω to develop the 160 mV required to achieve the 4-V full-scale output with the gain set to 25 V/V. The power dissipated across this 16-m Ω resistor at the 10-A current level is 1.6 W, which is a fairly high power dissipation for this component. Adjusting the device gain allows alternate current-sense resistor values to be selected to ease the power dissipation requirement of this component.

Changing the gain setting from 25 V/V to 100 V/V, as shown in [Table 2](#), decreases the maximum differential input voltage from 160 mV down to 40 mV, thus requiring only a 4-mΩ current-sensing resistor to achieve the 4-V output at the 10-A current level. The power dissipated across this resistor at the 10-A current level is 400 mW, significantly increasing the availability of component options to select from.

The increase in gain by a factor of four reduces the power dissipation requirement of the current-sensing resistor by this same factor of four. However, with this smaller full-scale signal, the measurement uncertainty resulting from the device fixed input offset voltage increases by the same factor of four. The measurement error resulting from the device input offset voltage is approximately 0.1% at the 160-mV full-scale input signal for the 25-V/V gain setting. Increasing the gain to 100 V/V and decreasing the full-scale input signal to 40 mV increases the offset induced measurement error to 0.38%.

Table 2. Accuracy and R_{SENSE} Power Dissipation vs Gain Setting

PARAMETER		EQUATION	RESULT
I_{MAX}	Full-scale current		10 A
V_{OUT}	Full-scale output voltage		4 V
Gain	Gain selected		100 V/V
V_{DIFF}	Ideal maximum differential input voltage	$V_{DIFF} = V_{OUT} / \text{Gain}$	40 mV
R_{SENSE}	Current-sense resistor value	$R_{SENSE} = V_{DIFF} / I_{MAX}$	4 mΩ
P_{RSENSE}	Current-sense resistor power dissipation	$R_{SENSE} \times I_{MAX}^2$	0.4 W
V_{OS} Error	Offset voltage error	$(V_{OS} / V_{DIFF}) \times 100$	0.375%

7.3.2 Programmable Gain Select

The device features a terminal-controlled gain selection in determining the device gain setting. Four discrete gain options are available (25 V/V, 50 V/V, 100 V/V, and 200 V/V) on the device and are selected based on the voltage levels applied to the gain-select terminals (GS0 and GS1). These terminals are typically fixed settings for most applications but the programmable gain feature can be used to adjust the gain setting to enable wider dynamic input range monitoring as well as to create an automatic gain control (AGC) network.

[Table 3](#) shows the corresponding gain values and gain-select terminal values for the device.

Table 3. Gain Select Settings

GAIN	GS0	GS1
25 V/V	GND	GND
50 V/V	GND	V_S
100 V/V	V_S	GND
200 V/V	V_S	V_S

7.4 Device Functional Modes

7.4.1 Input Filtering

An obvious and straightforward location for filtering is at the device output; however, this location negates the advantage of the low output impedance of the internal buffer. The input then represents the best location for implementing external filtering. Figure 36 shows the typical implementation of the input filter for the device.

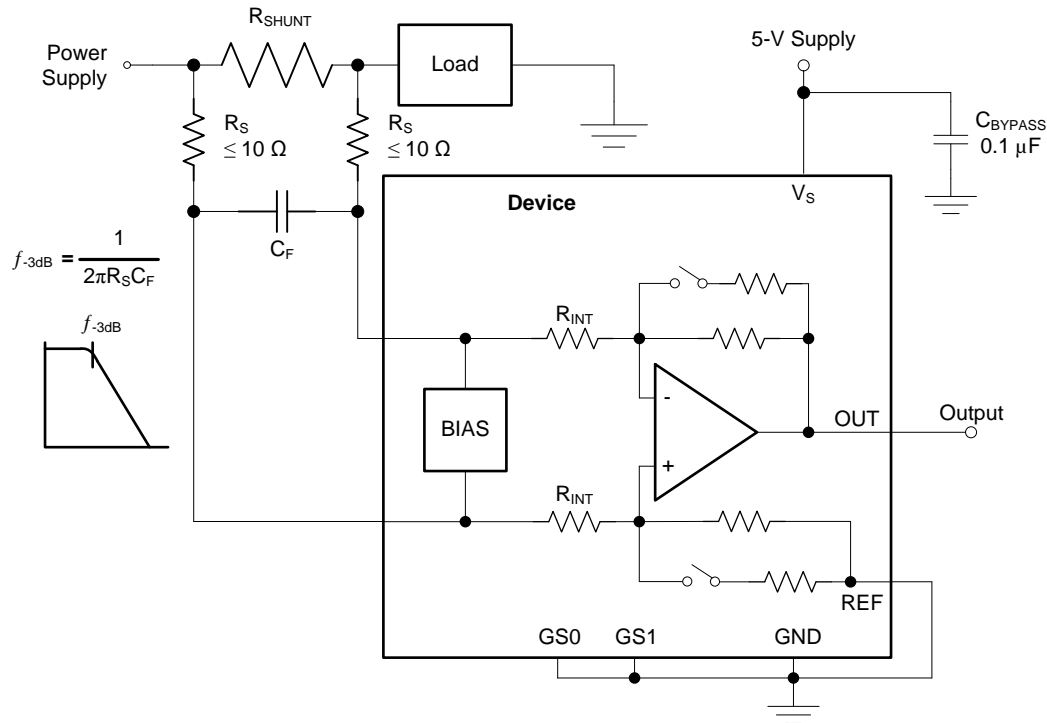

Figure 36. Input Filter

Care must be taken in the selection of the external filter component values because these components can affect device measurement accuracy. Placing external resistance in series with the input terminals creates an additional error so these resistors should be kept as low of a value as possible with a recommended maximum value of 10 Ω or less. Increasing the value of the input filter resistance beyond 10 Ω results in a smaller voltage signal present at the device input terminals than what is developed across the current-sense shunt resistor.

The internal bias network shown in Figure 36 creates a mismatch in the two input bias current paths when a differential voltage is applied between the input terminals. Under normal conditions, where no external resistance is added to the input paths, this mismatch of input bias currents has little effect on device operation or accuracy. However, when additional external resistance is added (such as for input filtering), the mismatch of input bias currents creates unequal voltage drops across these external components. The mismatched voltages result in a signal reaching the input terminals that is lower in value than the signal developed directly across the current-sensing resistor.

The amount of variance in the differential voltage present at the device input relative to the voltage developed at the shunt resistor is based both on the external series resistance value (R_S) and the internal input resistors (R_{INT}). The reduction of the shunt voltage reaching the device input terminals appears as a gain error when comparing the output voltage relative to the voltage across the shunt resistor. A factor can be calculated to determine the amount of gain error that is introduced by the addition of external series resistance.

Device Functional Modes (continued)

The amount of error these external filter resistors introduce into the measurement can be calculated using the simplified gain error factor in Equation 1, where the gain error factor is calculated with Equation 2.

$$\text{Gain Error Factor} = \frac{50,000}{(41 \times R_S) + 50,000} \quad (1)$$

$$\text{Gain Error Factor} = \frac{(1250 \times R_{INT})}{(1250 \times R_S) + (1250 \times R_{INT}) + (R_S \times R_{INT})}$$

where:

- R_{INT} is the internal input impedance, and
- R_S is the external series resistance. (2)

For example, using the gain error factor (Equation 1), a 10-Ω series resistance results in a gain error factor of 0.992. The corresponding gain error is then calculated using Equation 3, resulting in a gain error of approximately 0.81% solely because of the external 10-Ω series resistors. Using 100-Ω filter resistors increases this gain error to approximately 7.58% from these resistors alone.

$$\text{Gain Error (\%)} = 1 - \text{Gain Error Factor} \quad (3)$$

7.4.2 Shutting Down the Device

Although the device does not have a shutdown terminal, the low-power consumption allows for the device to be powered from the output of a logic gate or transistor switch that can turn on and turn off the voltage connected to the device power-supply terminal.

However, in current-shunt monitoring applications, there is also a concern for how much current is drained from the shunt circuit in shutdown conditions. Evaluating this current drain involves considering the device simplified schematic in shutdown mode, as shown in Figure 37.

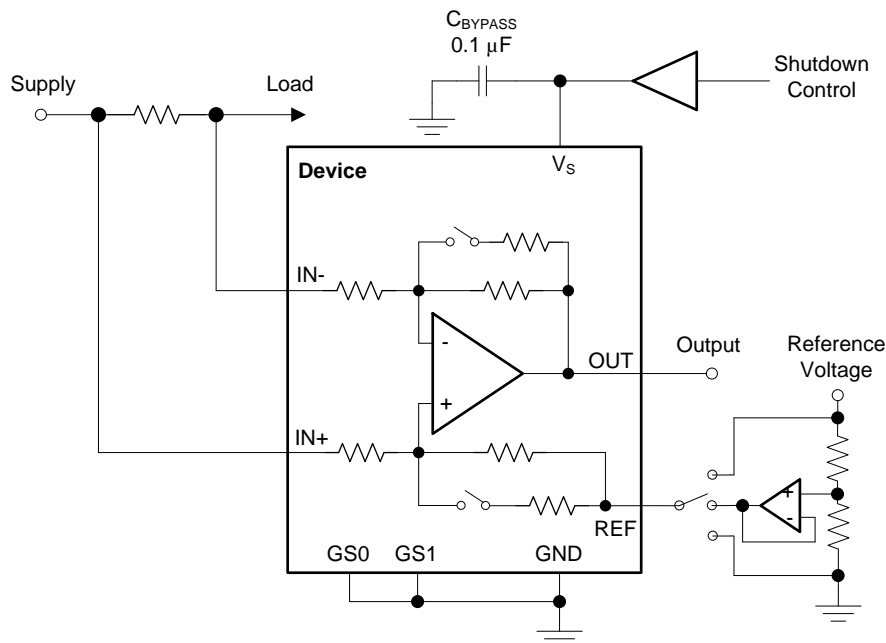

Figure 37. Shutting Down the Device

Device Functional Modes (continued)

Note that there is typically a 525-k Ω impedance (from the combination of the 500-k Ω feedback and 25-k Ω input resistors) from each device input to the REF terminal. The amount of current flowing through these terminals depends on the respective configuration. For example, if the REF terminal is grounded, calculating the effect of the 525-k Ω impedance from the shunt to ground is straightforward. However, if the reference or op amp is powered while the device is shut down, the calculation is direct. Instead of assuming 525 k Ω to ground, assume 525 k Ω to the reference voltage. If the reference or op amp is also shut down, some knowledge of the reference or op amp output impedance under shutdown conditions is required. For instance, if the reference source behaves similar to an open circuit when un-powered, little or no current flows through the 525-k Ω path.

7.4.3 Using the Device with Common-Mode Transients Above 36 V

With a small amount of additional circuitry, the device can be used in circuits subject to transients higher than 36 V (such as automotive applications). Use only zener diodes or zener-type transient absorbers (sometimes referred to as *transzorb*s); any other type of transient absorber has an unacceptable time delay. Start by adding a pair of resistors, as shown in Figure 38, as a working impedance for the zener. Keeping these resistors as small as possible is preferable, most often around 10 Ω . This value limits the impact on accuracy with the addition of these external components, as described in the *Input Filtering* section. Larger values can be used if necessary with the result having an impact on gain error. Because this circuit limits only short-term transients, many applications are satisfied with a 10- Ω resistor along with conventional zener diodes of the lowest power rating available. This combination uses the least amount of board space. These diodes can be found in packages as small as SOT-523 or SOD-523.

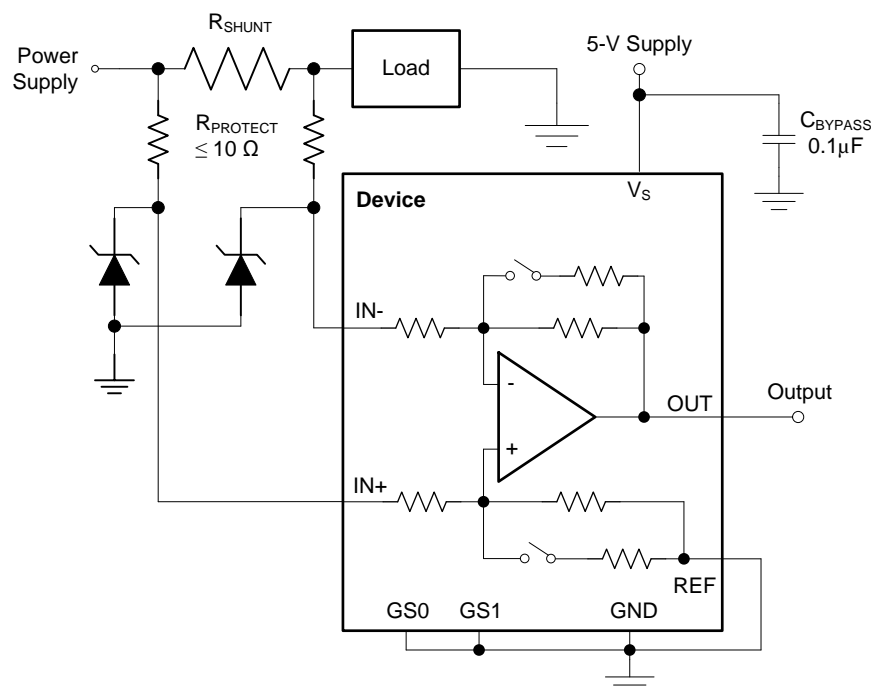

Figure 38. Device Transient Protection

8 Applications and Implementation

NOTE

Information in the following applications sections is not part of the TI component specification, and TI does not warrant its accuracy or completeness. TI's customers are responsible for determining suitability of components for their purposes. Customers should validate and test their design implementation to confirm system functionality.

8.1 Application Information

The INA225-Q1 measures the voltage developed across a current-sensing resistor when current passes through it. The ability to drive the reference terminal to adjust the functionality of the output signal offers multiple configurations discussed throughout this section.

8.2 Typical Applications

8.2.1 Microcontroller-Configured Gain Selection

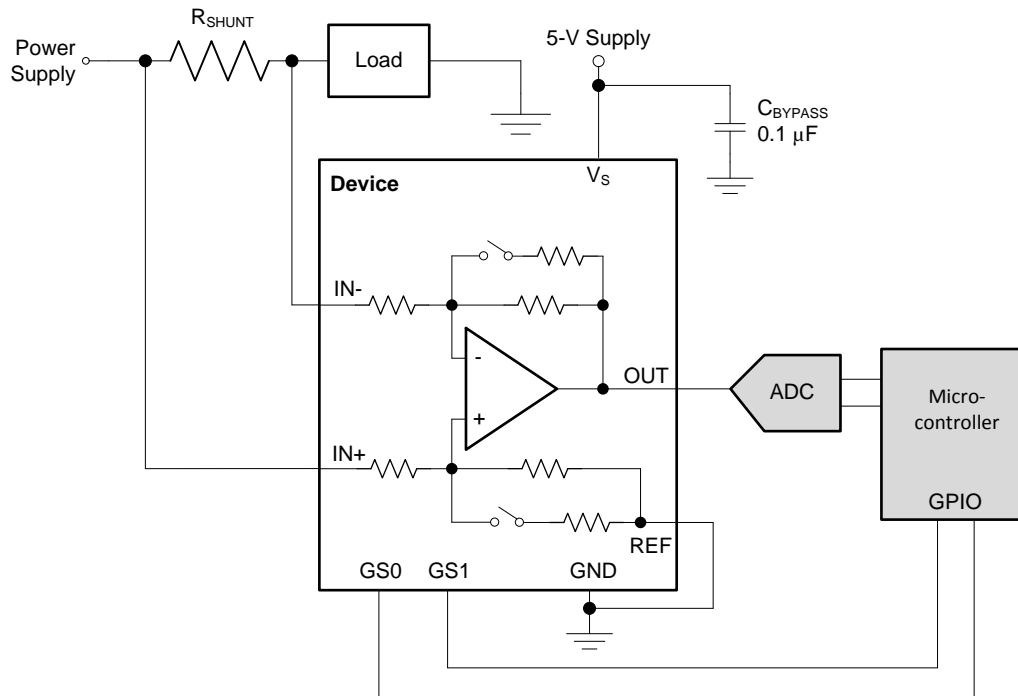

Figure 39. Microcontroller-Configured Gain Selection Schematic

8.2.1.1 Design Requirements

Figure 39 shows the typical implementation of the device interfacing with an analog-to-digital converter (ADC) and microcontroller.

8.2.1.2 Detailed Design Procedure

In this application, the device gain setting is selected and controlled by the microcontroller to ensure the device output is within the linear input range of the ADC. Because the output range of the device under a specific gain setting approaches the linear output range of the INA225-Q1 itself or the linear input range of the ADC, the microcontroller can adjust the device gain setting to ensure the signal remains within both the device and the ADC linear signal range.

Typical Applications (continued)

8.2.1.3 Application Curve

Figure 40 illustrates how the microcontroller can monitor the ADC measurements to determine if the device gain setting should be adjusted to ensure the output of the device remains within the linear output range as well as the linear input range of the ADC. When the output of the device rises to a level near the desired maximum voltage level, the microcontroller can change the GPIO settings connected to the G0 and G1 gain-select terminals to adjust the device gain setting, thus resulting in the output voltage dropping to a lower output range. When the input current increases, the output voltage increases again to the desired maximum voltage level. The microcontroller can again change the device gain setting to drop the output voltage back to a lower range.

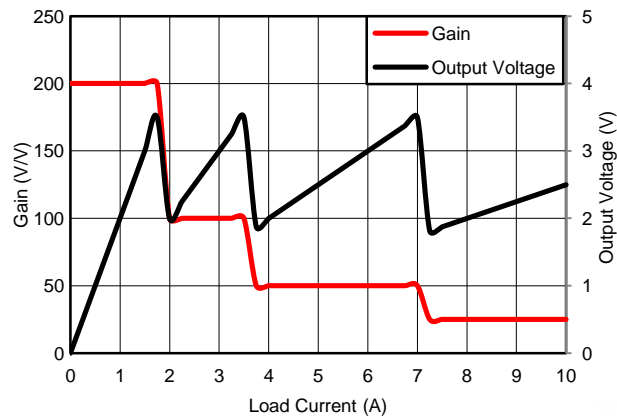

Figure 40. Microcontroller-Configured Gain Selection Response

Typical Applications (continued)

8.2.2 Unidirectional Operation

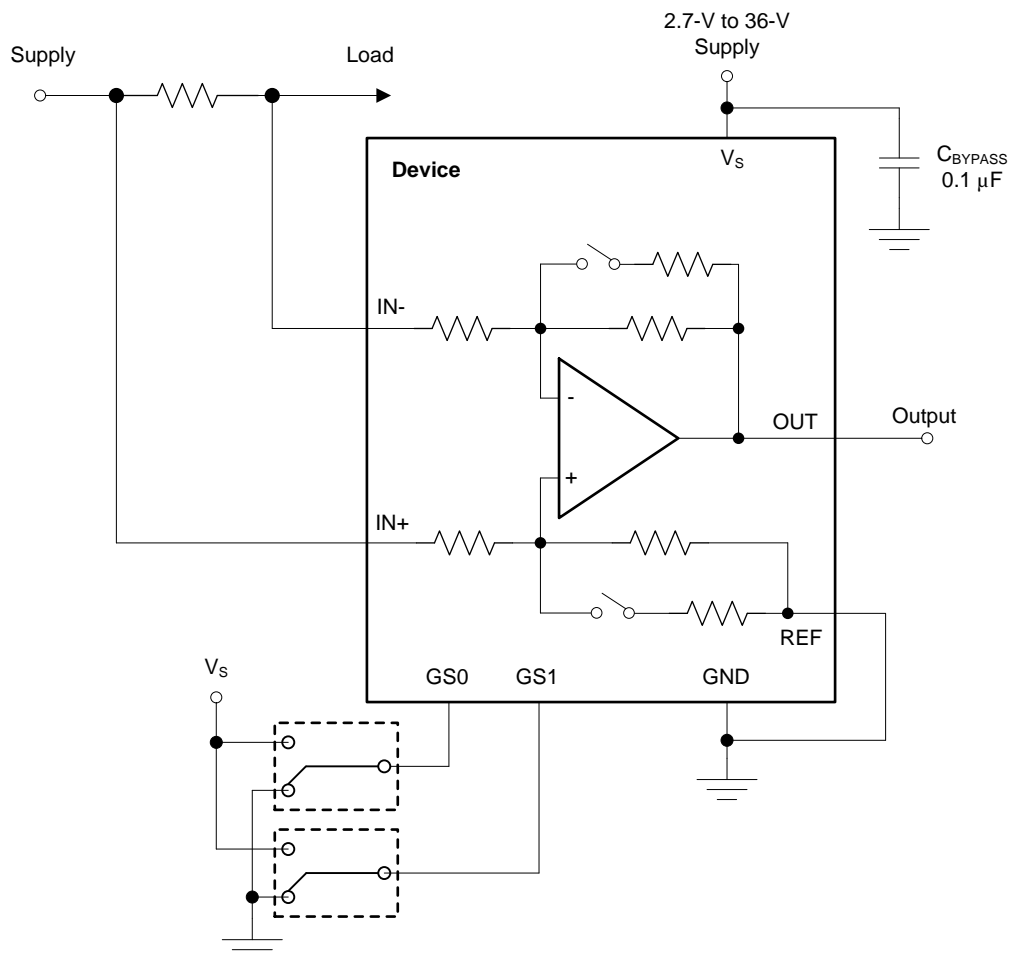

Figure 41. Unidirectional Application Schematic

8.2.2.1 Design Requirements

The device can be configured to monitor current flowing in one direction or in both directions, depending on how the REF terminal is configured. For measuring current in one direction, only the REF terminal is typically connected to ground as shown in Figure 41. With the REF terminal connected to ground, the output is low with no differential input signal applied. When the input signal increases, the output voltage at the OUT terminal increases above ground based on the device gain setting.

Typical Applications (continued)

8.2.2.2 Detailed Design Procedure

The linear range of the output stage is limited in how close the output voltage can approach ground under zero input conditions. Resulting from an internal node limitation when the REF terminal is grounded (unidirectional configuration) the device gain setting determines how close to ground the device output voltage can achieve when no signal is applied; see [Figure 14](#). To overcome this internal node limitation, a small reference voltage (approximately 10 mV) can be applied to the REF terminal to bias the output voltage above this voltage level. The device output swing capability returns to the 10-mV saturation level with this small reference voltage present.

At the lowest gain setting, 25 V/V, the device is capable of accurately measuring input signals that result in output voltages below this 10-mV saturation level of the output stage. For these gain settings, a reference voltage can be applied to bias the output voltage above this lower saturation level to allow the device to monitor these smaller input signals. To avoid common-mode rejection errors, buffer the reference voltage connected to the REF terminal.

A less frequently-used output biasing method is to connect the REF terminal to the supply voltage, V_S . This method results in the output voltage saturating at 200 mV below the supply voltage when no differential input signal is present. This method is similar to the output saturated low condition with no input signal when the REF terminal is connected to ground. The output voltage in this configuration only responds to negative currents that develop negative differential input voltage relative to the device $IN-$ terminal. Under these conditions, when the differential input signal increases negatively, the output voltage moves downward from the saturated supply voltage. The voltage applied to the REF terminal must not exceed the device supply voltage.

8.2.2.3 Application Curve

An example output response of a unidirectional configuration is shown in [Figure 42](#). With the REF terminal connected directly to ground, the output voltage is biased to this zero output level. The output rises above the reference voltage for positive differential input signals but cannot fall below the reference voltage for negative differential input signals because of the grounded reference voltage.

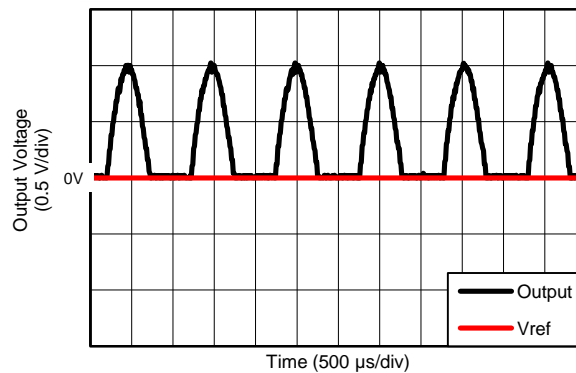

Figure 42. Unidirectional Application Output Response

Typical Applications (continued)

8.2.3 Bidirectional Operation

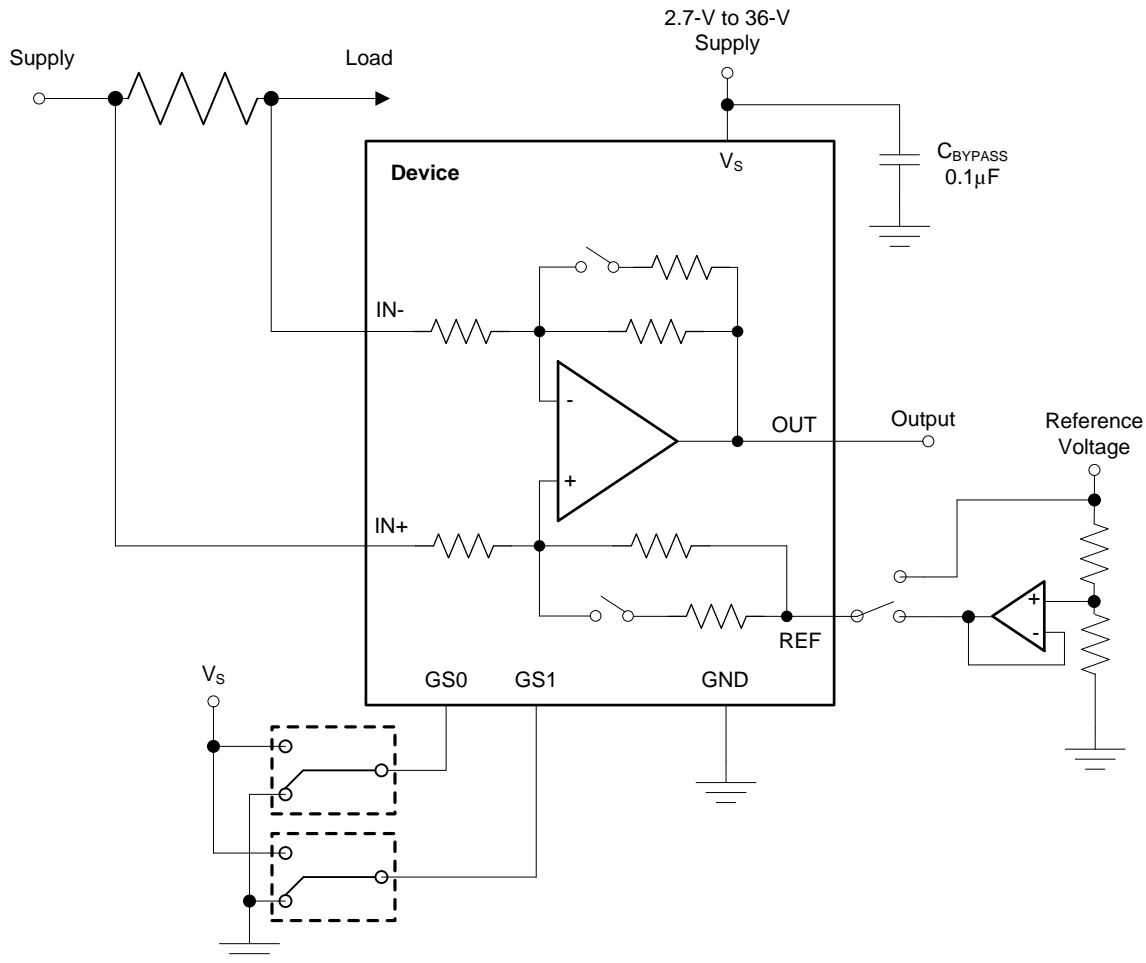

Figure 43. Bidirectional Application Schematic

8.2.3.1 Design Requirements

The device is a bidirectional, current-sense amplifier capable of measuring currents through a resistive shunt in two directions. This bidirectional monitoring is common in applications that include charging and discharging operations where the current flow-through resistor can change directions.

8.2.3.2 Detailed Design Procedure

The ability to measure this current flowing in both directions is enabled by applying a voltage to the REF terminal, as shown in Figure 43. The voltage applied to REF (V_{REF}) sets the output state that corresponds to the zero-input level state. The output then responds by increasing above V_{REF} for positive differential signals (relative to the IN– terminal) and responds by decreasing below V_{REF} for negative differential signals. This reference voltage applied to the REF terminal can be set anywhere between 0 V to V_S . For bidirectional applications, V_{REF} is typically set at mid-scale for equal range in both directions. In some cases, however, V_{REF} is set at a voltage other than half-scale when the bidirectional current is non-symmetrical.

Typical Applications (continued)

8.2.3.3 Application Curve

An example output response of a bidirectional configuration is shown in Figure 44. With the REF terminal connected to a reference voltage, 2.5 V in this case, the output voltage is biased upwards by this reference level. The output rises above the reference voltage for positive differential input signals and falls below the reference voltage for negative differential input signals.

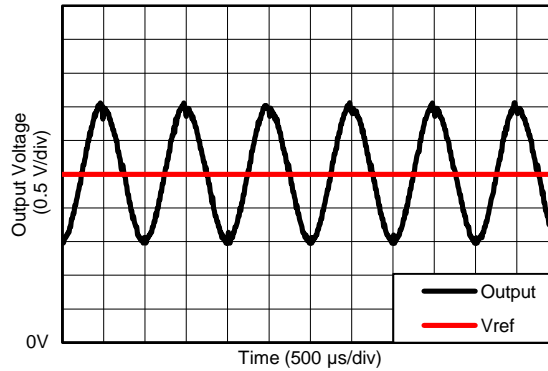

Figure 44. Bidirectional Application Output Response

9 Power Supply Recommendations

The input circuitry of the device can accurately measure signals on common-mode voltages beyond its power supply voltage, V_S . For example, the voltage applied to the V_S power supply terminal can be 5 V, whereas the load power-supply voltage being monitored (the common-mode voltage) can be as high as +36 V. Note also that the device can withstand the full -0.3-V to $+36\text{-V}$ range at the input terminals, regardless of whether the device has power applied or not.

Power-supply bypass capacitors are required for stability and should be placed as closely as possible to the supply and ground terminals of the device. A typical value for this supply bypass capacitor is $0.1\ \mu\text{F}$. Applications with noisy or high-impedance power supplies may require additional decoupling capacitors to reject power-supply noise.

10 Layout

10.1 Layout Guidelines

- Connect the input terminals to the sensing resistor using a Kelvin or 4-wire connection. This connection technique ensures that only the current-sensing resistor impedance is detected between the input terminals. Poor routing of the current-sensing resistor commonly results in additional resistance present between the input terminals. Given the very low ohmic value of the current resistor, any additional high-current carrying impedance can cause significant measurement errors.
- The power-supply bypass capacitor should be placed as closely as possible to the supply and ground terminals. The recommended value of this bypass capacitor is $0.1\ \mu\text{F}$. Additional decoupling capacitance can be added to compensate for noisy or high-impedance power supplies.

10.2 Layout Example

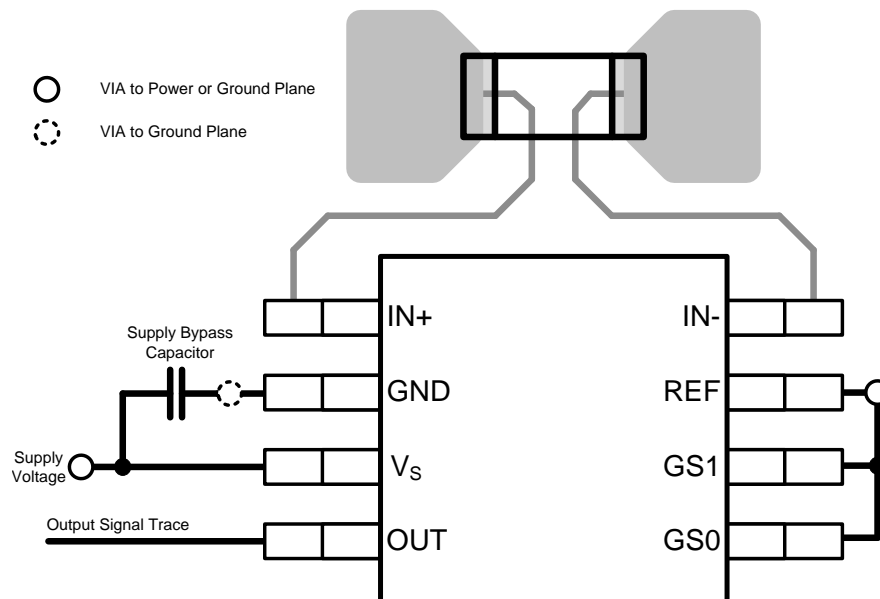

Figure 45. Recommended Layout

NOTE

The layout shown has REF connected to ground for unidirectional operation. Gain-select terminals (GS0 and GS1) are also connected to ground, indicating a 25-V/V gain setting.

11 Device and Documentation Support

11.1 Related Documentation

For related documentation see the following:

- INA225EVM User's Guide, [SBOU140](#)

11.2 Trademarks

All trademarks are the property of their respective owners.

11.3 Electrostatic Discharge Caution



This integrated circuit can be damaged by ESD. Texas Instruments recommends that all integrated circuits be handled with appropriate precautions. Failure to observe proper handling and installation procedures can cause damage.

ESD damage can range from subtle performance degradation to complete device failure. Precision integrated circuits may be more susceptible to damage because very small parametric changes could cause the device not to meet its published specifications.

11.4 Glossary

[SLYZ022](#) — *TI Glossary*.

This glossary lists and explains terms, acronyms, and definitions.

12 Mechanical, Packaging, and Orderable Information

The following pages include mechanical packaging and orderable information. This information is the most current data available for the designated devices. This data is subject to change without notice and revision of this document. For browser-based versions of this data sheet, refer to the left-hand navigation.

PACKAGING INFORMATION

Orderable Device	Status (1)	Package Type	Package Drawing	Pins	Package Qty	Eco Plan (2)	Lead/Ball Finish (6)	MSL Peak Temp (3)	Op Temp (°C)	Device Marking (4/5)	Samples
INA225AQDGKRQ1	ACTIVE	VSSOP	DGK	8	2500	Green (RoHS & no Sb/Br)	CU NIPDAUAG	Level-2-260C-1 YEAR	-40 to 125	IAAQ	Samples

(1) The marketing status values are defined as follows:

ACTIVE: Product device recommended for new designs.

LIFEBUY: TI has announced that the device will be discontinued, and a lifetime-buy period is in effect.

NRND: Not recommended for new designs. Device is in production to support existing customers, but TI does not recommend using this part in a new design.

PREVIEW: Device has been announced but is not in production. Samples may or may not be available.

OBSELETE: TI has discontinued the production of the device.

(2) Eco Plan - The planned eco-friendly classification: Pb-Free (RoHS), Pb-Free (RoHS Exempt), or Green (RoHS & no Sb/Br) - please check <http://www.ti.com/productcontent> for the latest availability information and additional product content details.

TBD: The Pb-Free/Green conversion plan has not been defined.

Pb-Free (RoHS): TI's terms "Lead-Free" or "Pb-Free" mean semiconductor products that are compatible with the current RoHS requirements for all 6 substances, including the requirement that lead not exceed 0.1% by weight in homogeneous materials. Where designed to be soldered at high temperatures, TI Pb-Free products are suitable for use in specified lead-free processes.

Pb-Free (RoHS Exempt): This component has a RoHS exemption for either 1) lead-based flip-chip solder bumps used between the die and package, or 2) lead-based die adhesive used between the die and leadframe. The component is otherwise considered Pb-Free (RoHS compatible) as defined above.

Green (RoHS & no Sb/Br): TI defines "Green" to mean Pb-Free (RoHS compatible), and free of Bromine (Br) and Antimony (Sb) based flame retardants (Br or Sb do not exceed 0.1% by weight in homogeneous material)

(3) MSL, Peak Temp. - The Moisture Sensitivity Level rating according to the JEDEC industry standard classifications, and peak solder temperature.

(4) There may be additional marking, which relates to the logo, the lot trace code information, or the environmental category on the device.

(5) Multiple Device Markings will be inside parentheses. Only one Device Marking contained in parentheses and separated by a "~" will appear on a device. If a line is indented then it is a continuation of the previous line and the two combined represent the entire Device Marking for that device.

(6) Lead/Ball Finish - Orderable Devices may have multiple material finish options. Finish options are separated by a vertical ruled line. Lead/Ball Finish values may wrap to two lines if the finish value exceeds the maximum column width.

Important Information and Disclaimer: The information provided on this page represents TI's knowledge and belief as of the date that it is provided. TI bases its knowledge and belief on information provided by third parties, and makes no representation or warranty as to the accuracy of such information. Efforts are underway to better integrate information from third parties. TI has taken and continues to take reasonable steps to provide representative and accurate information but may not have conducted destructive testing or chemical analysis on incoming materials and chemicals. TI and TI suppliers consider certain information to be proprietary, and thus CAS numbers and other limited information may not be available for release.

In no event shall TI's liability arising out of such information exceed the total purchase price of the TI part(s) at issue in this document sold by TI to Customer on an annual basis.

OTHER QUALIFIED VERSIONS OF INA225-Q1 :

- Catalog: [INA225](#)

NOTE: Qualified Version Definitions:

- Catalog - TI's standard catalog product

TAPE AND REEL INFORMATION

QUADRANT ASSIGNMENTS FOR PIN 1 ORIENTATION IN TAPE

*All dimensions are nominal

Device	Package Type	Package Drawing	Pins	SPQ	Reel Diameter (mm)	Reel Width W1 (mm)	A0 (mm)	B0 (mm)	K0 (mm)	P1 (mm)	W (mm)	Pin1 Quadrant
INA225AQDGKRQ1	VSSOP	DGK	8	2500	330.0	12.4	5.3	3.4	1.4	8.0	12.0	Q1

TAPE AND REEL BOX DIMENSIONS



*All dimensions are nominal

Device	Package Type	Package Drawing	Pins	SPQ	Length (mm)	Width (mm)	Height (mm)
INA225AQDGKRQ1	VSSOP	DGK	8	2500	366.0	364.0	50.0

DGK (S-PDSO-G8)

PLASTIC SMALL-OUTLINE PACKAGE



- NOTES:
- A. All linear dimensions are in millimeters.
 - B. This drawing is subject to change without notice.
 - C. Body length does not include mold flash, protrusions, or gate burrs. Mold flash, protrusions, or gate burrs shall not exceed 0.15 per end.
 - D. Body width does not include interlead flash. Interlead flash shall not exceed 0.50 per side.
 - E. Falls within JEDEC MO-187 variation AA, except interlead flash.

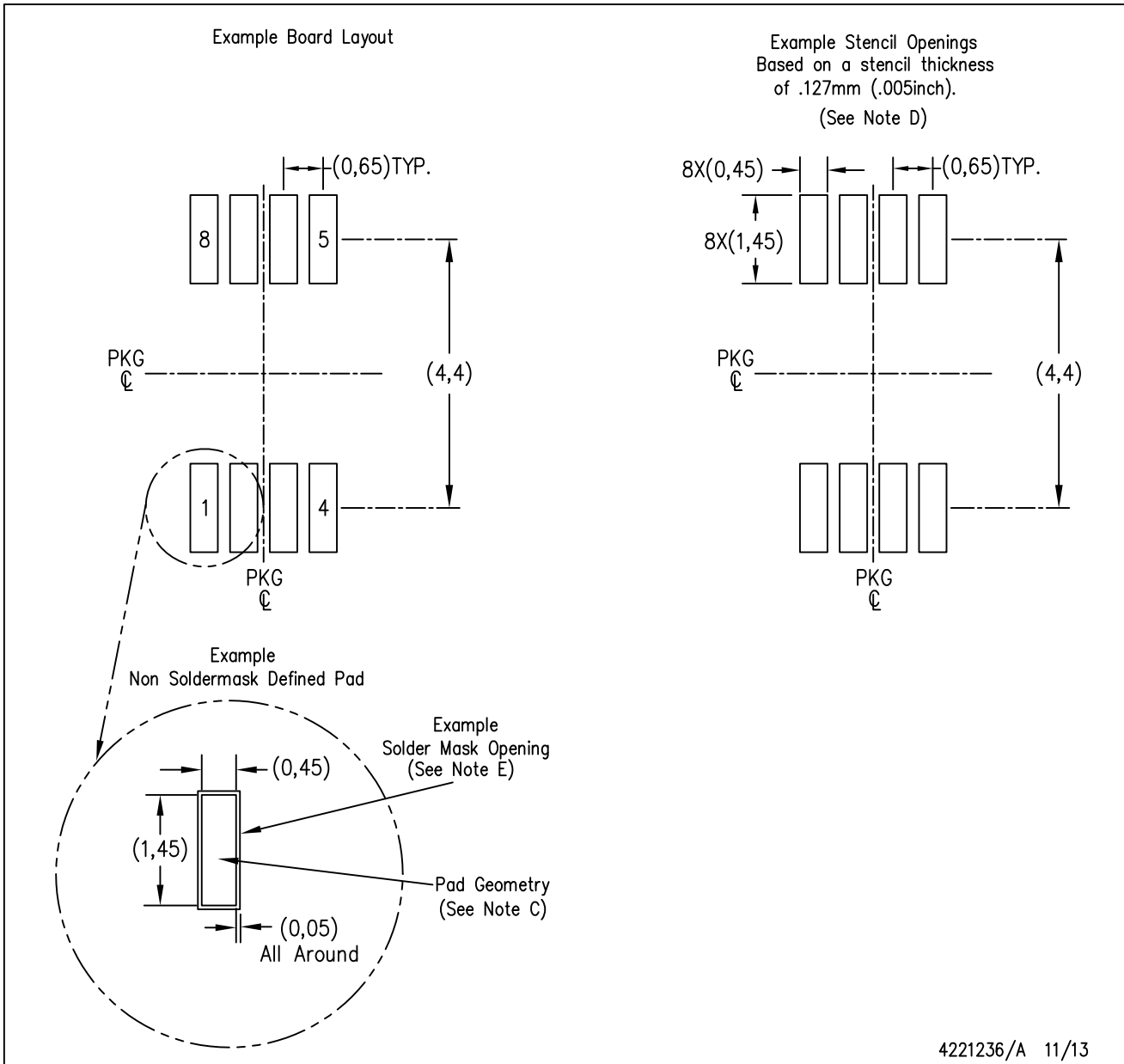

- NOTES:
- A. All linear dimensions are in millimeters.
 - B. This drawing is subject to change without notice.
 - C. Publication IPC-7351 is recommended for alternate designs.
 - D. Laser cutting apertures with trapezoidal walls and also rounding corners will offer better paste release. Customers should contact their board assembly site for stencil design recommendations. Refer to IPC-7525 for other stencil recommendations.
 - E. Customers should contact their board fabrication site for solder mask tolerances between and around signal pads.

IMPORTANT NOTICE AND DISCLAIMER

TI PROVIDES TECHNICAL AND RELIABILITY DATA (INCLUDING DATASHEETS), DESIGN RESOURCES (INCLUDING REFERENCE DESIGNS), APPLICATION OR OTHER DESIGN ADVICE, WEB TOOLS, SAFETY INFORMATION, AND OTHER RESOURCES "AS IS" AND WITH ALL FAULTS, AND DISCLAIMS ALL WARRANTIES, EXPRESS AND IMPLIED, INCLUDING WITHOUT LIMITATION ANY IMPLIED WARRANTIES OF MERCHANTABILITY, FITNESS FOR A PARTICULAR PURPOSE OR NON-INFRINGEMENT OF THIRD PARTY INTELLECTUAL PROPERTY RIGHTS.

These resources are intended for skilled developers designing with TI products. You are solely responsible for (1) selecting the appropriate TI products for your application, (2) designing, validating and testing your application, and (3) ensuring your application meets applicable standards, and any other safety, security, or other requirements. These resources are subject to change without notice. TI grants you permission to use these resources only for development of an application that uses the TI products described in the resource. Other reproduction and display of these resources is prohibited. No license is granted to any other TI intellectual property right or to any third party intellectual property right. TI disclaims responsibility for, and you will fully indemnify TI and its representatives against, any claims, damages, costs, losses, and liabilities arising out of your use of these resources.

TI's products are provided subject to TI's Terms of Sale (www.ti.com/legal/termsofsale.html) or other applicable terms available either on ti.com or provided in conjunction with such TI products. TI's provision of these resources does not expand or otherwise alter TI's applicable warranties or warranty disclaimers for TI products.

Mailing Address: Texas Instruments, Post Office Box 655303, Dallas, Texas 75265
Copyright © 2019, Texas Instruments Incorporated