

Pin 1 – ADJ.  
 Pin 2 –  $V_{IN}$   
 Pin 3 –  $V_{OUT}$   
 Case –  $V_{IN}$

**G Package – (TO-257AA)**

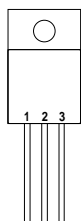

Pin 1 – ADJ.  
 Pin 2 –  $V_{IN}$   
 Pin 3 –  $V_{OUT}$

**IG Package – (TO-257AA)  
 (Isolated)**

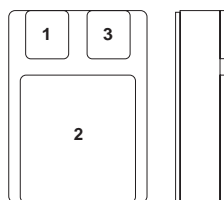

Pin 1 – ADJ.  
 Pin 2 –  $V_{IN}$   
 Pin 3 –  $V_{OUT}$

**SMD1 (TO276AB)**

**CERAMIC SURFACE MOUNT**

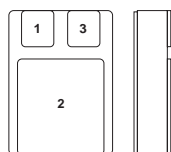

Pin 1 – ADJ.  
 Pin 2 –  $V_{IN}$   
 Pin 3 –  $V_{OUT}$

**SMD05 (TO-276AA)**

**CERAMIC SURFACE MOUNT**

**FEATURES**

- **OUTPUT VOLTAGE RANGE OF:**  
 1.25 TO 40V FOR STANDARD VERSION  
 1.25 TO 50V FOR –HV VERSION
- **1% OUTPUT VOLTAGE TOLERANCE**
- **0.3% LOAD REGULATION**
- **0.01%/V LINE REGULATION**
- **COMPLETE SERIES OF PROTECTIONS:**
  - **CURRENT LIMITING**
  - **THERMAL SHUTDOWN**
  - **SOA CONTROL**

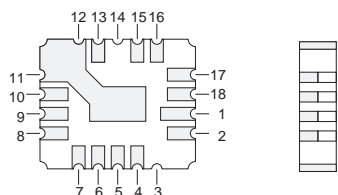

Pins 4,5 – ADJ.  
 Pins 6,7,8,9,10,11,12,13 –  $V_{OUT}$   
 Pins 15,16,17,18,1,2 –  $V_{IN}$

**LCC4**

**CERAMIC SURFACE MOUNT**

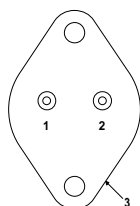

Pin 1 – ADJ.  
 Pin 2 –  $V_{OUT}$   
 Case –  $V_{IN}$

**K Package – TO-3 (TO-204AA)**

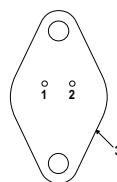

Pin 1 – ADJ.  
 Pin 2 –  $V_{OUT}$   
 Case –  $V_{IN}$

**R Package – TO-66  
 (TO-213AA)**

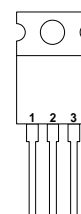

Pin 1 – ADJ.  
 Pin 2 –  $V_{IN}$   
 Pin 3 –  $V_{OUT}$   
 Case –  $V_{IN}$

**T Package – TO-220**

**ABSOLUTE MAXIMUM RATINGS** ( $T_{case} = 25^{\circ}C$  unless otherwise stated)

$V_{I-O}$	Input - Output Differential Voltage	– Standard – HV Series	40V 50V
$I_O$	Output Current		Internally limited
$P_D$	Power Dissipation		Internally limited
$T_j$	Operating Junction Temperature Range		See Order Information Table
$T_{stg}$	Storage Temperature		-65 to 150°C

Semelab Plc reserves the right to change test conditions, parameter limits and package dimensions without notice. Information furnished by Semelab is believed to be both accurate and reliable at the time of going to press. However Semelab assumes no responsibility for any errors or omissions discovered in its use. Semelab encourages customers to verify that datasheets are current before placing orders.

Parameter	Test Conditions	IP137A , IP137AHV LM137A , LM137AHV			IP137 , IP137HV LM137 , LM137HV			Units	
		Min.	Typ.	Max.	Min.	Typ.	Max.		
V <sub>REF</sub> Reference Voltage	I <sub>OUT</sub> = 10mA	-1.238	-1.25	-1.262	-1.225	-1.25	-1.275	V	
	I <sub>OUT</sub> = 10mA to I <sub>MAX</sub> T <sub>J</sub> = -55 to 150°C V <sub>IN</sub> - V <sub>OUT</sub> = 3V to V <sub>MAX</sub> P ≤ P <sub>MAX</sub>	-1.220	-1.25	-1.280	-1.200	-1.250	-1.300	V	
$\frac{\Delta V_{OUT}}{\Delta I_{OUT}}$ Line Regulation 1	V <sub>IN</sub> - V <sub>OUT</sub> = 3V to V <sub>MAX</sub> T <sub>J</sub> = -55 to 150°C	0.005	0.010		0.010	0.020	%V		
		0.010	0.030		0.020	0.050			
$\frac{\Delta V_{OUT}}{\Delta I_{OUT}}$ Load Regulation 1	I <sub>OUT</sub> = 10mA to I <sub>MAX</sub> V <sub>OUT</sub> ≤ 5V	5	25		15	25	mV		
		0.1	0.5		0.3	0.5	%		
	I <sub>OUT</sub> = 10mA to I <sub>MAX</sub> V <sub>OUT</sub> ≤ 5V T <sub>J</sub> = -55 to 150°C	10	50		20	50	mV		
		0.2	1		0.3	1	%		
Thermal Regulation	t <sub>p</sub> = 10ms    T <sub>A</sub> = 25°C LCC4 Package	0.002	0.020		0.002	0.02	%W		
				0.040		0.040			
Ripple Rejection	V <sub>OUT</sub> = -10V f = 120Hz C <sub>ADJ</sub> = 0 C <sub>ADJ</sub> = 10μF T <sub>J</sub> = -55 to 150°C	60	66		60		dB		
		70	80		66	77	dB		
I <sub>ADJ</sub> Adjust Pin Current	T <sub>J</sub> = -55 to 150°C	65	100		65	100	μA		
ΔI <sub>ADJ</sub> Adjust Pin Current Change	T <sub>J</sub> = -55 to 150°C	I <sub>OUT</sub> = 10mA to I <sub>MAX</sub>	0.2	2		0.5	5	μA	
		V <sub>IN</sub> - V <sub>OUT</sub> = 3V to 40V	1.0	5		2	5		
		V <sub>IN</sub> - V <sub>OUT</sub> = 3V to 50V (HV SERIES)	2.0	6		3	6		
I <sub>MIN</sub> Minimum Load Current	T <sub>J</sub> = -55 to 150°C	V <sub>IN</sub> - V <sub>OUT</sub> ≤ 40V	2.5	5		2.5	5	mA	
		V <sub>IN</sub> - V <sub>OUT</sub> ≤ 10V	1.2	3		1.2	3		
I <sub>CL</sub> Current Limit	T <sub>J</sub> = -55 to 150°C	V <sub>IN</sub> - V <sub>OUT</sub> ≤ 15V	1.5	2.2	3.2	1.5	2.2	3.2	A
		V <sub>IN</sub> - V <sub>OUT</sub> = 40V	0.24	0.4	1	0.24	0.4		
		V <sub>IN</sub> - V <sub>OUT</sub> = 50V (HV SERIES)	0.2	0.4	0.8	0.2	0.4	0.8	
$\frac{\Delta V_{OUT}}{\Delta TEMP}$ Temperature Stability	T <sub>J</sub> = -55 to 150°C		0.6	1.5		0.6		%	
$\frac{\Delta V_{OUT}}{\Delta TIME}$ Long Term Stability	T <sub>A</sub> = +125°C t = 1000 Hrs		0.3	1		0.3	1	%	
e <sub>n</sub> RMS Output Noise (% of V <sub>OUT</sub> )	f = 10 Hz to 10 kHz T <sub>A</sub> = 25°C		0.003			0.003		%	
R <sub>θJC</sub> Thermal Resistance Junction to Case	K Package		2.3	3		2.3	3	°C/W	
	R Package		5	7		5	7		
	G Package		3	5		3	5		
	LCC4 Package			13			13		

1) Regulation is measured at constant junction temperature, using pulse testing at a low duty cycle. Changes in output voltage due to heating effects are covered under thermal regulation specifications. Load regulation is measured at a point 1/8" from the bottom of the package for the TO-3 and TO-66 packages, at the junction of the wide and narrow portion of the output lead for the SMD packages, and 1/8" below the base of the package on the output pin of the TO-257 package.

2) Test Conditions unless otherwise stated: V<sub>IN</sub> - V<sub>OUT</sub> = 5V , I<sub>OUT</sub> = 0.5A , P<sub>MAX</sub> = 20W , I<sub>MAX</sub> = 1.5A , V<sub>MAX</sub> = 40V for standard series , 50V for HV series.

Semelab Plc reserves the right to change test conditions, parameter limits and package dimensions without notice. Information furnished by Semelab is believed to be both accurate and reliable at the time of going to press. However Semelab assumes no responsibility for any errors or omissions discovered in its use. Semelab encourages customers to verify that datasheets are current before placing orders.

Parameter	Test Conditions	IP337A IP337AHV			IP337, IP337HV LM337, LM337HV			Units	
		Min.	Typ.	Max.	Min.	Typ.	Max.		
V <sub>REF</sub> Reference Voltage	I <sub>OUT</sub> = 10mA	-1.238	-1.25	-1.262	-1.213	-1.25	-1.287	V	
	I <sub>OUT</sub> = 10mA to I <sub>MAX</sub> V <sub>IN</sub> - V <sub>OUT</sub> = 3V to V <sub>MAX</sub> P ≤ P <sub>MAX</sub> T <sub>J</sub> = 0 to 125°C	-1.220	-1.25	-1.280	-1.200	-1.250	-1.300	V	
$\frac{\Delta V_{OUT}}{\Delta I_{OUT}}$ Line Regulation 1	V <sub>IN</sub> - V <sub>OUT</sub> = 3V to V <sub>MAX</sub> T <sub>J</sub> = 0 to 125°C		0.005	0.010		0.010	0.040	%V	
			0.010	0.030		0.020	0.070		
$\frac{\Delta V_{OUT}}{\Delta I_{OUT}}$ Load Regulation 1	I <sub>OUT</sub> = 10mA to I <sub>MAX</sub>	V <sub>OUT</sub> ≤ 5V		5	25		15	50	mV
		V <sub>OUT</sub> ≥ 5V		0.1	0.5		0.3	1	%
	I <sub>OUT</sub> = 10mA to I <sub>MAX</sub> T <sub>J</sub> = 0 to 125°C	V <sub>OUT</sub> ≤ 5V		10	50		20	70	mV
		V <sub>OUT</sub> ≥ 5V		0.2	1		0.3	1.5	%
Thermal Regulation	t <sub>p</sub> = 10ms                    T <sub>A</sub> = 25°C		0.002	0.020		0.003	0.04	%/W	
Ripple Rejection	V <sub>OUT</sub> = 10V f = 120Hz	C <sub>ADJ</sub> = 0	60	66		60		dB	
		C <sub>ADJ</sub> = 10μF T <sub>J</sub> = 0 to 125°C	70	80		66	77	dB	
I <sub>ADJ</sub> Adjust Pin Current	T <sub>J</sub> = 0 to 125°C		65	100		65	100	μA	
ΔI <sub>ADJ</sub> Adjust Pin Current Change	T <sub>J</sub> = 0 to 125°C	I <sub>OUT</sub> = 10mA to I <sub>MAX</sub>		0.2	2		0.5	5	μA
		V <sub>IN</sub> - V <sub>OUT</sub> = 3V to 40V		1.0	5		2	5	
		V <sub>IN</sub> - V <sub>OUT</sub> = 3V to 50V <b>(HV SERIES)</b>		2.0	6		3	6	
I <sub>MIN</sub> Minimum Load Current	T <sub>J</sub> = 0 to 125°C	V <sub>IN</sub> - V <sub>OUT</sub> ≤ 40V		2.5	5		2.5	10	mA
		V <sub>IN</sub> - V <sub>OUT</sub> ≤ 10V		1.2	3		1	6	
I <sub>CL</sub> Current Limit	T <sub>J</sub> = 0 to 125°C	V <sub>IN</sub> - V <sub>OUT</sub> ≤ 15V	1.5	2.2	3.5	1.5	2.2	3.5	A
		V <sub>IN</sub> - V <sub>OUT</sub> = 40V	0.24	0.4	1	0.15	0.4		
		V <sub>IN</sub> - V <sub>OUT</sub> = 50V <b>(HV SERIES)</b>	0.2	0.4	0.8	0.1	0.4	0.8	
$\frac{\Delta V_{OUT}}{\Delta TEMP}$ Temperature Stability	T <sub>J</sub> = 0 to 125°C		0.6	1.5		0.6		%	
$\frac{\Delta V_{OUT}}{\Delta TIME}$ Long Term Stability	t = 1000 Hrs		0.3	1		0.3	1	%	
e <sub>n</sub> RMS Output Noise (% of V <sub>OUT</sub> )	f = 10 Hz to 10 kHz T <sub>A</sub> = 25°C		0.003			0.003		%	
R <sub>θJC</sub> Thermal Resistance Junction to Case	K Package		2.3	3		2.3	3	°C/W	
	T Package		4	5		4			
	LCC4 Package			13			13		

1) Regulation is measured at constant junction temperature, using pulse testing at a low duty cycle. Changes in output voltage due to heating effects are covered under thermal regulation specifications. Load regulation is measured at a point 1/8" from the bottom of the package for the TO-3 and TO-66 packages, at the junction of the wide and narrow portion of the output lead for the SMD packages, and 1/8" below the base of the package on the output pin of the TO-257 package.

2) Test Conditions unless otherwise stated:                    V<sub>IN</sub> - V<sub>OUT</sub> = 5V, I<sub>OUT</sub> = 0.5A, P<sub>MAX</sub> = 20W, I<sub>MAX</sub> = 1.5A  
V<sub>MAX</sub> = 40V for standard series, 50V for HV series.

Semelab Plc reserves the right to change test conditions, parameter limits and package dimensions without notice. Information furnished by Semelab is believed to be both accurate and reliable at the time of going to press. However Semelab assumes no responsibility for any errors or omissions discovered in its use. Semelab encourages customers to verify that datasheets are current before placing orders.

## APPLICATIONS INFORMATION

### High Stability Regulator

The output stability, load regulation, line regulation, thermal regulation, temperature drift, long term drift, and noise, can be improved by a factor of 6.6 over the standard regulator configuration. This assumes a zener has 20PPM/°C maximum drift and about 10 times lower noise than the regulator.

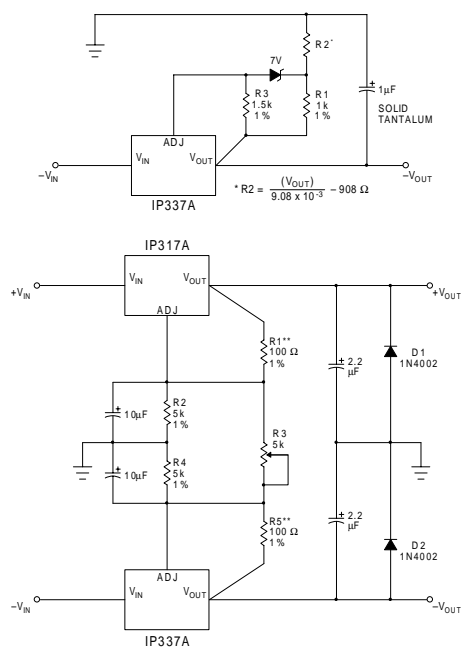

\* Solid Tantalum  
\*\* R1 or R5 may be trimmed slightly to improve tracking.

### Dual Tracking Supply

### Multiple Tracking Regulators

In the application shown below, regulator #2 to "N" will track regulator #1 to within ±24mV initially, and to ±60mV over all load, line, and temperature conditions.

If any regulator output is shorted to ground, all other outputs will drop to -2V. Load regulation of regulators 2 to "N" will be improved by  $V_{OUT} / 1.25V$  compared to a standard regulator, so regulator #1 should be the one which has the lowest load current.

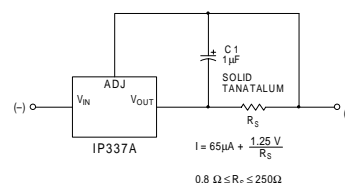
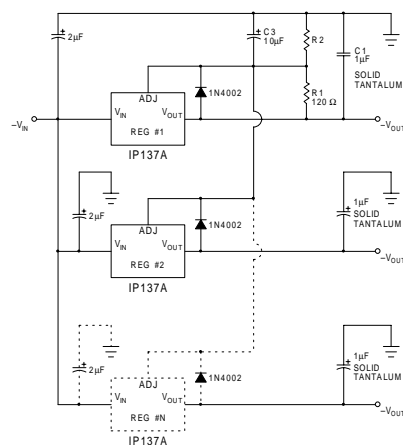

### Current Regulator

## Order Information

Part Number	IG-Pack G-Pack (TO257)	SMD1	SMD05	LCC4	K-Pack (TO3)	R-Pack (TO66)	T-Pack (TO220)	Temp. Range
LM137	✓	✓	✓	✓	✓	✓		-55 to +150°C
LM137HV	✓	✓	✓	✓	✓	✓		"
LM137A	✓	✓	✓	✓	✓	✓		"
LM137AHV	✓	✓	✓	✓	✓	✓		"
IP137	✓	✓	✓	✓	✓	✓		"
IP137HV	✓	✓	✓	✓	✓	✓		"
IP137A	✓	✓	✓	✓	✓	✓		"
IP137AHV	✓	✓	✓	✓	✓	✓		"
LM337					✓		✓	0 to 125°C
LM337HV					✓		✓	"
IP337					✓		✓	"
IP337HV					✓		✓	"
IP337A					✓		✓	"
IP337AHV					✓		✓	"

Semelab Plc reserves the right to change test conditions, parameter limits and package dimensions without notice. Information furnished by Semelab is believed to be both accurate and reliable at the time of going to press. However Semelab assumes no responsibility for any errors or omissions discovered in its use. Semelab encourages customers to verify that datasheets are current before placing orders.

**Semelab plc.** Telephone +44(0)1455 556565. Fax +44(0)1455 552612.

E-mail: [sales@semelab.co.uk](mailto:sales@semelab.co.uk) Website: <http://www.semelab.co.uk>

Document Number 2831

Issue 3