

Fully-Integrated Power Bank System-On-Chip with 2.1A charger, 2.1A discharger and DCP support

1 Features

- **Synchronous switching charger and synchronous boost converter**
 - ◇ 2.1A synchronous switching charger, 2.1A synchronous boost converter
 - ◇ Boost converter efficiency up to 92%
 - ◇ Switching charger efficiency up to 91%
 - ◇ Integrated power-path management, charging batteries and charging cellphones at the same time
- **Charger**
 - ◇ Adaptive charging current control, excellent adapter compatibility
 - ◇ Support 4.20V, 4.35V and 4.4V batteries with different R_{VSET}
 - ◇ Support battery thermal protection (with NTC resistor)
 - ◇ Programmable charging current with a resistor R_{ICHG}
- **State of charge (SOC) indicator**
 - ◇ Integrated LED controller supports 4/3/2/1 LEDs as the SOC indicator
 - ◇ Configurable charging/discharging curve with a resistor R_{VTHS} , makes the SOC indicate LEDs more even
- **Fully featured**
 - ◇ Integrated flashlight controller
 - ◇ Integrated cellphone plug-in and plug-out detector
 - ◇ Integrated a DCP modules for detect cellphone charging current
 - ◇ Support output cable resistor compensation
- **Low power**
 - ◇ Smart load detector, switching to standby mode automatically
 - ◇ $<100 \mu A$ standby current
- **Ultra simplified BOM**
 - ◇ Integrated power FET, charging/boosting

with a single inductor

- **Multiple protections, high reliability**
 - ◇ Output over-current, over-voltage, short-circuit protection
 - ◇ Input over-voltage, over-current, battery over-charge, over-drain, over-current protection
 - ◇ Thermal Shutdown
 - ◇ ESD 4KV, maximum 11V transit over-voltage sustainable

2 Applications

- Power bank, Portable Charger
- Mobile Phones, Handheld Devices

3 Description

IP5189T is a fully-integrated multi-function power management SOC. It integrates a boost converter, a Li battery charger management system and a battery state of charge indicate controller. It provides a turn-key solution for power bank and portable charger applications.

IP5189T's high integration and rich features make the minimized component number in application. It can effectively downsize the application and lower the BOM cost.

IP5189T only needs a single inductor to realize step-down and step-up.

IP5189T's synchronous step-up converter provides 2.1A output current. Its efficiency is up to 92% @ $V_{BAT}=3.7V, I_{out}=2.1A$. It can switch to standby mode at empty load automatically, the standby current reducing to 100uA.

IP5189T's synchronous switching charger provides 2.1A charging current. Its efficiency is up to 91% @ $V_{IN}=5.0V, V_{BAT}=3.7V, I_{bat}=2A$. It regulates the charging current by IC temperature and input voltage.

IP5189T integrates voltage based fuel gauge indication of 1/2/3/4 LEDs and flashlight function.

IP5189T is available in QFN24 (4*4mm)

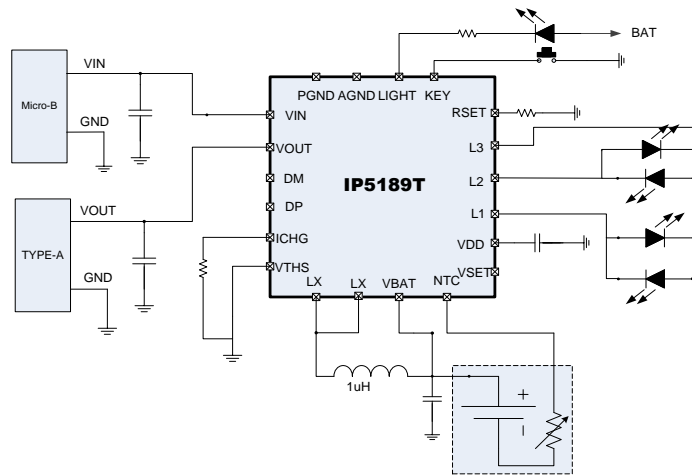

Fig1 Simplified application schematic (4 LEDs as the SOC indicator)

4 Pin definition

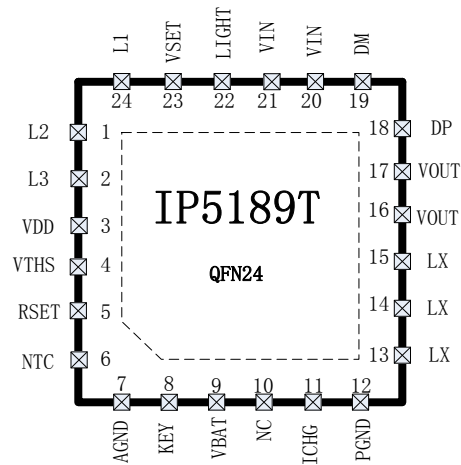

Fig 2 IP5189T Pin Diagram

Index	Name	Descriptions
1	L2	Battery indicator pin L2
2	L3	Battery indicator pin L3
3	VDD	Integrated LDO Regulator output(3.1V)
4	VTHS	Battery platform select
5	RSET	Battery resistance select
6	NTC	NTC pin
7	AGND	Analog gnd
8	KEY	Key input pin
9	VBAT	Battery connection point to the positive terminal of the battery pack
10	NC	NC
11	ICHG	Set Charge current, pull down to GND with a resistor R_{ICHG}
12	PGND	Power ground
13、14、15	LX	DCDC switch node, connect to inductor
16、17	VOUT	DCDC 5V OUTPUT pin
18	DP	USB D+
19	DM	USB D-
20、21	VIN	Charger 5V INPUT pin
22	LIGHT	Output for Flash Light Driver, Open drain
23	VSET	Battery voltage select
24	L1	Battery indicator pin L1
25(EPAD)	GND	EPAD, should be connected to GND

5 The PartList of PowerBank SoC

PartNum	charger	Boost	LEDs	Torch	KEY	I2C	DCP	Type-C	Quick Charge	Package	
IP5303	1.0A	1.2A	1,2	√	√	-	-	-	-	eSOP8	PIN2PIN
IP5305	1.0A	1.2A	1,2,3,4	√	√	-	-	-	-	eSOP8	
IP5306	2.4A	2.1A	1,2,3,4	√	√	√	-	-	-	eSOP8	
IP5108	2.0A	2.0A	3,4,5	√	√	√	-	-	-	eSOP16	
IP5207T	1.2A	1.2A	3,4,5	√	√	-	√	-	-	QFN24	
IP5109	2.1A	2.1A	3,4,5	√	√	√	-	-	-	QFN24	PIN2PIN
IP5209	2.4A	2.1A	3,4,5	√	√	√	√	-	-	QFN24	
IP5189T	2.1A	2.1A	1,2,3,4	√	√	-	√	-	-	QFN24	
IP5219	2.4A	3A	1,2,3,4	√	√	√	√	√	-	QFN24	
IP5310	3.1A	3A	1,2,3,4	√	√	√	√	√	-	QFN32	
IP5312	15W	4A	2,3,4,5	√	√	√	√	-	√	QFN32	
IP5318Q	18W	4.8A	2,3,4,5	√	√	√	√	-	√	QFN40	PIN2PIN
IP5318	18W	4.8A	2,3,4,5	√	√	√	√	√	√	QFN40	

Order information

Part Num	Description
IP5189T	Standard product
IP5189T_YYY	Open Flash Light by two short push the key

6 Absolute maximum ratings

Parameter	symbol	value	Unit
Port input voltage range	V_{IN}	-0.3 ~ 6	V
Junction temperature	T_J	-40 ~ 150	°C
Storage temperature	T_{stg}	-60 ~ 150	°C
Thermal resistance (from junction to ambient air)	θ_{JA}	40	°C/W
Human-body model (HBM)	ESD	4	KV

* Stresses beyond those listed under absolute maximum ratings may cause permanent damage to the device. These are stress ratings only, and functional operation of the device at these or any other conditions beyond those indicated under recommended operating conditions is not implied. Exposure to absolute-maximum-rated conditions for extended periods may affect device reliability.

7 Recommended operation conditions

Parameter	symbol	MIN	Typical	MAX	Unit
Input voltage	V_{IN}	4.75	5	5.5	V
Load current	I	0	2.1		A

*Beyond these operation conditions, the device's performance will not be guaranteed.

8 Electrical Characteristics

TA=25°C, L=1uH, VIN=5V, BAT=3.8V unless otherwise noted

Parameter	symbol	Test condition	MIN	TYP	MAX	Unit
Charger system						
Input voltage	V _{IN}		4.65	5	5.5	V
Input voltage OVP	V _{INOVP}		5.51	5.6	5.7	V
Input voltage UVP	V _{INUVP}		4.3	4.4	4.65	V
CV charge voltage	CV _{4.2V}	VSET is floating	4.21	4.24	4.27	V
	CV _{4.35V}	VSET is connected to GND	4.36	4.38	4.42	V
	CV _{4.4V}	VSET is connected to VBAT	4.41	4.43	4.46	V
stop charge current	I _{stop}	VIN=5V	200	400	600	mA
Charge current	I _{VIN}	VIN=5V	1.6	1.9	2.2	A
Trickle charge current	I _{TRKL}	VIN=5v, BAT=2.7v	50	150	300	mA
Trickle charge stop voltage	V _{TRKL}		2.9	3	3.1	V
Recharge threshold	V _{RCH}		4.08	4.1	4.13	V
Charger safety timer	T _{END}		20	24	27	Hour
Boost system						
Battery operation voltage	V _{BAT}		3.0	3.7	4.4	V
Battery low protection voltage	V _{BATLOW}	IOUT=1A	2.9	2.95	3.05	V
Battery operation current	I _{BAT}	VBAT=3.7V, VOUT=5.1V, fs=375KHz	2	5	20	mA
DC-DC output voltage	V _{OUT}	VBAT=3.7V @0A	5.0	5.12	5.25	V
		VBAT=3.7V @3.1A	4.75	5	5.15	V
Output voltage ripple	ΔV _{OUT}	VBAT=3.7V, VOUT=5.0V, fs=375KHz	50	100		mV
Boost output current	I _{vout}		0	2.1	3	A
Boost output shutdown current			2.4	2.8	3.2	A
Load over-current detect timer	T _{UVD}	Output voltage continuously lower than 4.4V	10	30	50	ms
Load short-circuit detect timer	T _{OCd}	Output current continuously larger than 5A	100	150	200	us
Control system						

Switching frequency	fs	Boost switching frequency	400	500	600	KHz
		Charger switching frequency	600	700	800	KHz
PMOS on resistance	r _{DSON}		15	20	25	mΩ
NMOS on resistance			10	15	20	mΩ
PMOS between VIN and VOUT on resistance		VIN=5V	60	75	90	mΩ
Battery standby current	I _{STB}	VIN=0V, VBAT=3.7V	50	150	150	uA
LED lighting current	I _{light}		20	30	40	mA
LED indicator current	I _{L1}		2	10	20	mA
	I _{L2}					
	I _{L3}					
Load removal detect timer	T _{loadD}	Load current continuously lower than 45mA	25	32	44	s
Push-button wake-up timer	T _{OnDebounce}		50	60	500	ms
Push-button light-on timer	T _{Keylight}		2	2.5	3.3	s
Thermal shutdown	T _{OTP}	Rising temperature	125	140	150	°C
Thermal shutdown hysteresis	ΔT _{OTP}		30	40	50	°C

9 Function description

Boost converter

IP5189T integrates a 5V output step-up DCDC converter with 2.1A output capacity. It works at 500 KHz. When input battery voltage is 3.7V, its efficiency is 92% with the output of 5V/2A. Internal soft-start circuit prevents malfunction caused by starting inrush current. It integrate short-circuit, over-voltage, over-voltage protection, making the system stable and reliable.

IP5189T supports output cable resistor compensation. The large load will cause voltage drop in the output cable, IP5189T has a build-in cable compensation function. When the load current is greater than 1A, output voltage will increase 100mV.

Charger

IP5189T integrates a synchronous constant-current and constant-voltage switching Li battery charger. When battery is below 3.0V, the charger is in trickle mode, and charging current is 100mA. When battery is above 3V, the charger turns to constant-current mode, and constant-voltage mode is used if battery voltage reaches 4.35V. When charge is over, recharge will begin if battery is below 4.1V.

IP5189T's switching charger has a 700KHz switching frequency, and its maximum charging current is 2.1A, charging efficiency is up to 91%@VIN=5V,BAT=3.7V,Ibat=2.1A, shortening 3/4 charging time in comparison with the normal chargers.

IP5189T integrates an adaptive power-path management system with priority to output load. It can charge batteries as well as cellphones at the same time.

IP5189T's charger can adapt the charging current to the adapter of various load capacity, which can keep adapters away from malfunction.

IP5189T can use ICHG PIN to change charging current.

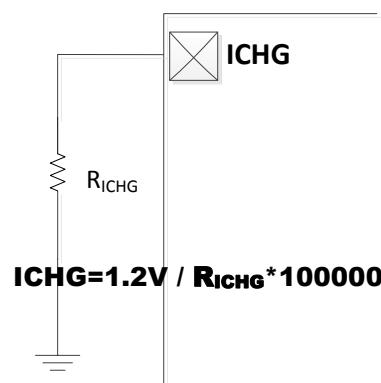

Fig3 Change charging current with different R_{ICHG}

R _{CHG}	Charging current(I _{VIN})
120Kohm	1A
100Kohm	1.2A
82Kohm	1.5A
56Kohm	2.1A
NC	Default(1.8A)

Push Button

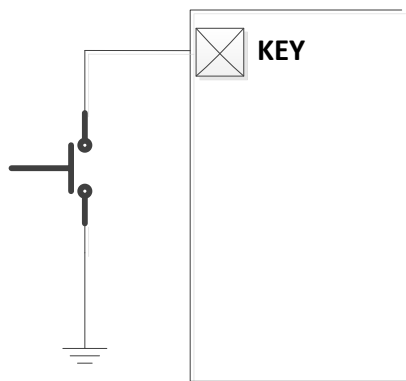

Fig4 Push button(KEY)

Push button's connecting is shown in Fig 4. IP5189T can identify long push and short push.

- If button is pushed longer than 80ms but shorter than 2s, IP5189T will identify the action as short push. Short push will open SOC indicator LEDs and step-up converter
- If button is pushed longer than 2s, IP5189T will identify the action as long push. Long push will open or close flashlight LED.
- If button is pushed shorter than 80ms, IP5189T will ignore the action.
- If two short push is detected within 1s, IP5189T will close step-up converter, SOC indicator LED and flashlight LED.

If you order *IP5189T_YYY*, push button is defined as:

- If button is pushed longer than 80ms but shorter than 2s, will identify the action as short push. Short push will open SOC indicator LEDs and step-up converter
- If two short push is detected within 1s, will close step-up converter, SOC indicator LED and flashlight LED.
- If button is pushed shorter than 80ms, will ignore the action.
- If button is pushed longer than 2s, will equate as short push.

State Of Charge (SOC) indication

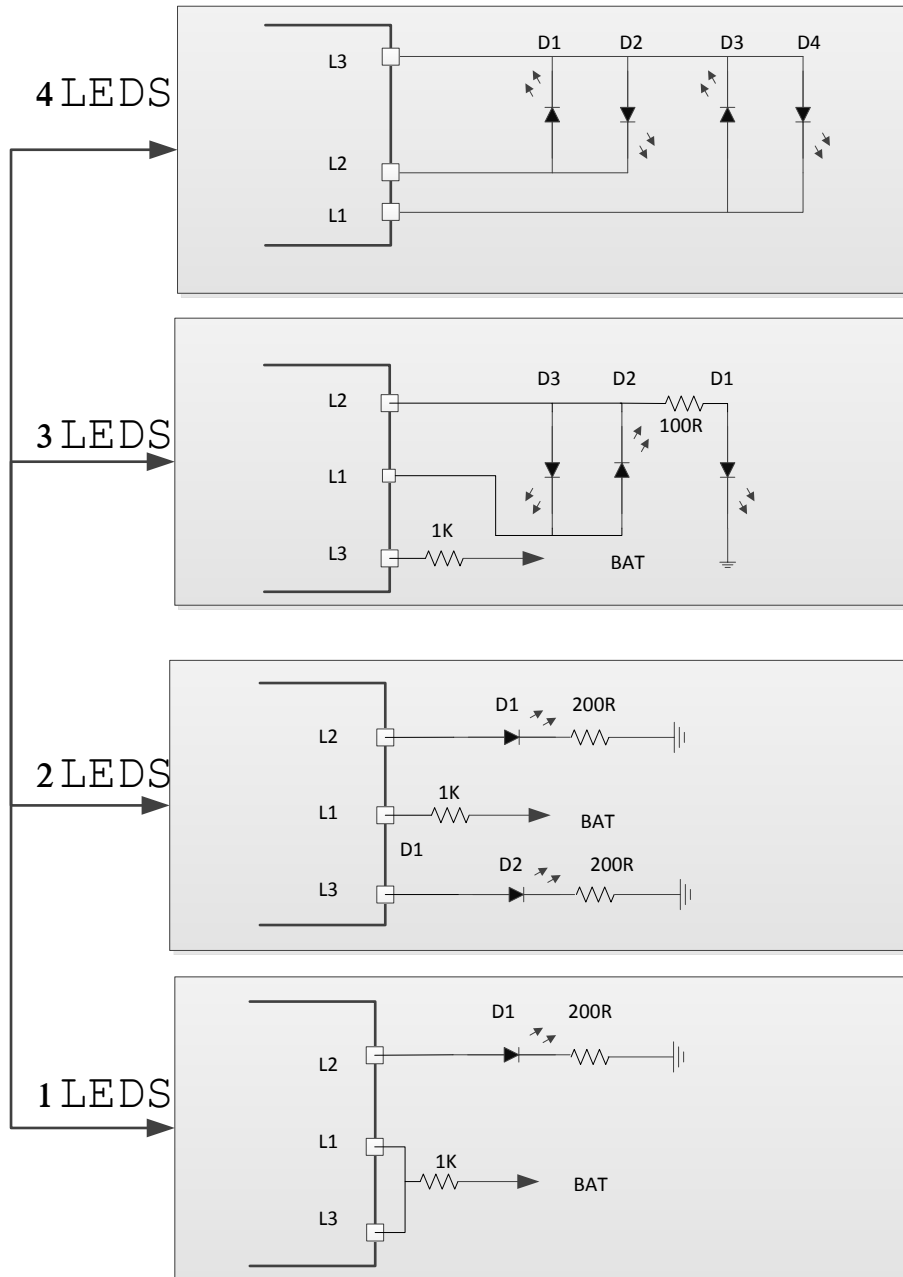

Fig 5 4/3/2/1 LED PIN configuration

■ 4 LEDs mode

Discharging mode, 4 LEDs as the indicator

SOC (%)	L1	L2	L3	L4
$SOC \geq 75\%$	ON	ON	ON	ON
$50\% \leq SOC < 75\%$	ON	ON	ON	OFF
$25\% \leq SOC < 50\%$	ON	ON	OFF	OFF
$3\% \leq SOC < 25\%$	ON	OFF	OFF	OFF
$0\% < SOC < 3\%$	1Hz blink	OFF	OFF	OFF
$SOC = 0\%$	OFF	OFF	OFF	OFF

Charging mode 4 LEDs as the indicator

SOC (%)	L1	L2	L3	L4
Full	ON	ON	ON	ON
$75\% \leq SOC$	ON	ON	ON	1.5Hz blink
$50\% \leq SOC < 75\%$	ON	ON	1.5Hz blink	OFF
$25\% \leq SOC < 50\%$	ON	1.5Hz blink	OFF	OFF
$SOC < 25\%$	1.5Hz blink	OFF	OFF	OFF

■ 3 LEDs mode

The displays of 3 LEDs are similar to that of 4 LEDs. The corresponding SOC of each LED is presented in the following table.

	D1	D2	D3	D4
3 LEDs	33%	66%	100%	NA
4 LEDs	25%	50%	75%	100%

■ 2 LEDs Mode

	state	LED1	LED2
Charging	In charging	ON	OFF
	End of Charge	OFF	OFF
Boost	In discharging	OFF	ON
	Low Battery	OFF	1HZ Blink

■ 1 LED Mode

	状态	LED1
Charging	In charging	1.5HZ Blink
	End of Charge	ON
Boost	In discharging	ON
	Low Battery	1HZ Blink

Battery voltage selection

IP5189T can support different batteries by changing the connecting of VSET PIN. When VSET is floating, 4.2V battery is set. When VSET is connected to GND, 4.35V battery is set. When VSET is connected to VDD, 4.4V battery is set.

Battery platform selection

IP5189T can support different battery platform by changing the connecting of VTHS pin. When VTHS is connected to VDD, set the high platform for 3.7V battery. When VTHS is connected to GND, set the low platform for 3.6V battery.

The Relationship between OCV (battery voltage detected by IP5189T, after calculating the battery impedance compensation) and VTHS&VSET as follows:

	VTHS connect to VDD		VTHS connect to GND	
	4.2V battery (VSET float)	4.35V/4.4V battery (VSET connect to VDD or GND)	4.2V battery (VSET float)	4.35V/4.4V battery (VSET connect to VDD or GND)
4LED to 3LED	4.02V	4.02V	3.90V	3.90V
3LED to 2LED	3.84V	3.84V	3.72V	3.72V
2LED to 1LED	3.66V	3.72V	3.60V	3.60V
1LED to Blink	3.30V	3.30V	3.30V	3.30V

Battery impedance setting

IP5189T can set the battery impedance by RSET pin which make the SOC indicator LEDs display more evenly. The relationships between the resistance connected to RSET and battery impedance are shown in the following table.

RSET resistance(Kohm)	Battery impedance (mOhm)
10K	45
43K	67.5
120K	112.5
200K	90
NC	22.5

Automatic cellphone plug-in detect

IP5189T can automatically detect the cellphone's plug-in. When detecting the plug-in, IP5189T will wake up from standby mode and open the 5V step-up converter without push button action. IP5189T supports modules without push buttons.

Cellphone charging current smart detect

IP5189T integrates a DCP module which can smartly detect the cellphone's charging current. It automatically provides the correct signals on D+ and D-. It makes the cellphone's charging current to the maximum, accelerating the charging speed on cellphone.

IP5189T supports Apple, Samsung and BC1.2 interface's D+ D- specification

Supports D+ D- shorted USB DCP

Supports D+ 2.7V D-2.0V Apple 2.0A DCP

Supports D+ 1.2V D-1.2V Samsung 2.0A DCP

Supports D+ 2.7V D-2.7V Apple 2.4A DCP

NTC

IP5189T integrated NTC, and can detect battery pack temperature. IP5189T's NTC PIN will output 20uA current, then detect the voltage of NTC PIN to determine the temperature of the battery.

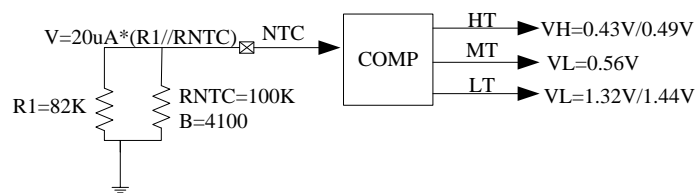

Fig 6 Battery NTC threshold

Charge:

If NTC pin voltage > 1.32V, it indicate the battery temperature is below 0 ° C, charger is stopped.

If NTC pin voltage < 0.56V, it indicate the battery temperature is higher 45 ° C, charger is stopped.

If NTC pin voltage < 0.49V, it indicate the battery temperature is higher 50 ° C, charger is stopped.

Discharge:

If NTC pin voltage > 1.44V, it indicate the battery temperature is below -10 ° C, discharger is stopped.

If NTC pin voltage < 0.43V, it indicate the battery temperature is higher 55 ° C, discharger is stopped.

If NTC function is not needed, the NTC pin should connect a 51K resistor to GND. The NTC pin cannot float otherwise may lead to abnormal.

Flash Light

IP5189T has an integrated MOS FET. LIGHT PIN in IP5189T can drive lighting LED directly. Maximum driving current is 25mA. When button is pushed longer than 2s or two short pushed within 1s (IP5189T_YYY), lighting LED is opened or closed.

If flash light is not needed, light should connect to GND, IP5189T will automatically close flash light function.

VDD

VDD is a 3.1V LDO which supply for the internal circuitry, should connect a 2.2uF capacitor.

When IP5189T work on, VDD will output 3.1V.

When IP5189T enter standby, VDD will shut down and has no output voltage.

11 Package information

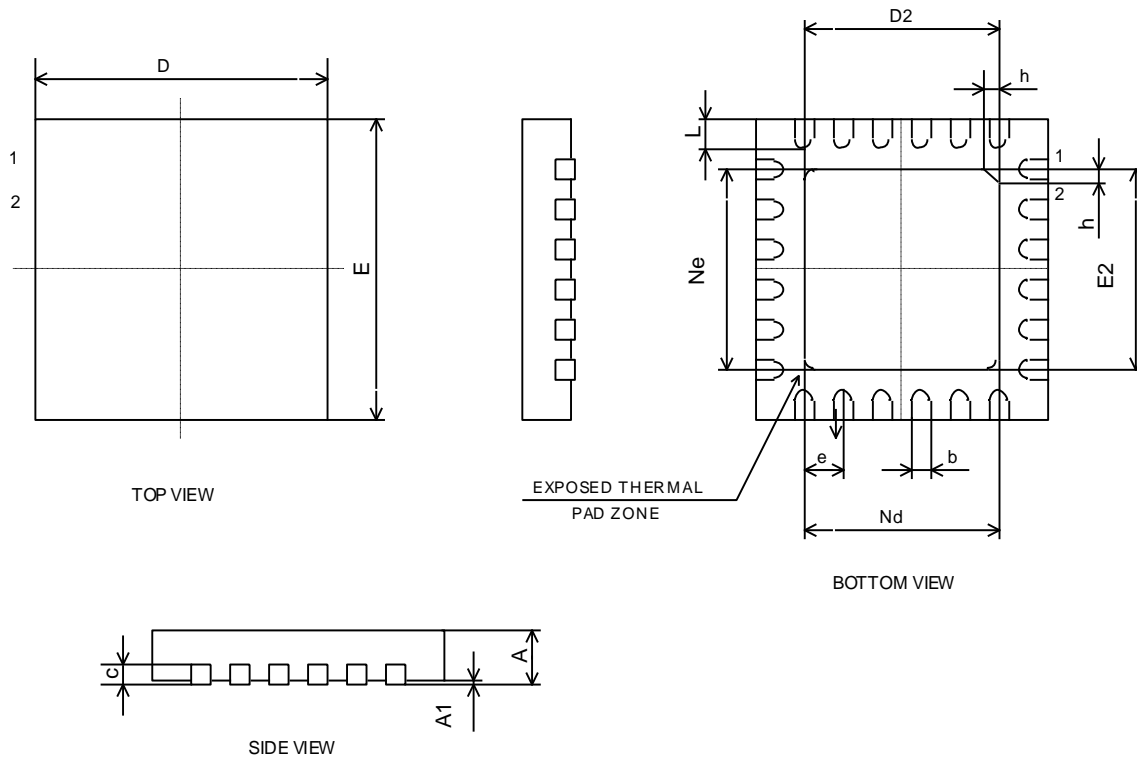

SYMBOL	MILLIMETER		
	MIN	NOM	MAX
A	0.70	0.75	0.80
A1	-	0.02	0.05
b	0.18	0.25	0.30
c	0.18	0.20	0.25
D	3.90	4.00	4.10
D2	2.40	2.50	2.60
e	0.50BSC		
Ne	2.50BSC		
Nd	2.50BSC		
E	3.90	4.00	4.10
E2	2.40	2.50	2.60
L	0.35	0.40	0.45
h	0.30	0.35	0.40

IMPORTANT NOTICE

INJOINIC TECHNOLOGY and its subsidiaries reserve the right to make corrections, enhancements, improvements and other changes to its semiconductor products and services. Buyers should obtain the latest relevant information before placing orders and should verify that such information is current and complete. All semiconductor products (also referred to herein as “components”) are sold subject to INJOINIC TECHNOLOGY’s terms and conditions of sale supplied at the time of order acknowledgment.

INJOINIC TECHNOLOGY assumes no liability for applications assistance or the design of Buyers' products. Buyers are responsible for their products and applications using INJOINIC TECHNOLOGY's components. To minimize the risks associated with Buyers' products and applications, Buyers should provide adequate design and operating safeguards.

Buyer acknowledges and agrees that it is solely responsible for compliance with all legal, regulatory and safety-related requirements concerning its products, and any use of INJOINIC TECHNOLOGY's components in its applications, notwithstanding any applications-related information or support that may be provided by INJOINIC TECHNOLOGY. Buyer represents and agrees that it has all the necessary expertise to create and implement safeguards which anticipate dangerous consequences of failures, monitor failures and their consequences, lessen the likelihood of failures that might cause harm and take appropriate remedial actions. Buyer will fully indemnify INJOINIC TECHNOLOGY and its representatives against any damages arising out of the use of any INJOINIC TECHNOLOGY's components in safety-critical applications.

Reproduction of significant portions of INJOINIC TECHNOLOGY's information in INJOINIC TECHNOLOGY's data books or data sheets is permissible only if reproduction is without alteration and is accompanied by all associated warranties, conditions, limitations, and notices. INJOINIC TECHNOLOGY is not responsible or liable for such altered documentation. Information of third parties may be subject to additional restrictions.

INJOINIC TECHNOLOGY will update this document from time to time. The actual parameters of the product may vary due to different models or other items. This document voids all express and any implied warranties.

Resale of INJOINIC TECHNOLOGY's components or services with statements different from or beyond the parameters stated by INJOINIC TECHNOLOGY for that component or service voids all express and any implied warranties for the associated INJOINIC TECHNOLOGY's component or service and is an unfair and deceptive business practice. INJOINIC TECHNOLOGY is not responsible or liable for any such statements.