

Support High Voltage SCP、Bi-directional PD3.0 、Fast Charge protocol and Double TYPE_C Power Bank SOC

1 Features

- **Support multiple ports simultaneously**
 - ◇ 2 USB C input / output port
 - ◇ 1 USB A output ports
 - ◇ 1 USB B input port
- **Fast charge**
 - ◇ Support 5V、9V、12V voltage input / output
 - ◇ Support QC2.0 / QC3.0 output
 - ◇ Support FCP input / output
 - ◇ Support AFC input / output
 - ◇ Support high voltage 10V@2.25A SCP output
 - ◇ Support USB C DRP input / output
 - ◇ Support BC1.2 / Apple / Samsung
- **Integrated USB PD2.0 / PD3.0 protocol**
 - ◇ Support PD2.0 input / output protocol
 - ◇ Support PD3.0 input / output and PPS output protocol
 - ◇ PPS support 3.3V~11V adjustable voltage with 20mV / Step
 - ◇ Integrate BMC protocol
 - ◇ Integrate Physical Layer protocol
 - ◇ Integrate hardware CRC
 - ◇ Support Hard Reset
- **Charger**
 - ◇ Support 18W charging power, Up to 5.0A charging current at battery port
 - ◇ Adaptive charging current adjustment
 - ◇ Support 4.20V、4.30V、4.35V、4.40V battery
- **Boost**
 - ◇ Output current:
 - ◇ 5V@3.1A 9V@2.22A 12V@1.67A
 - ◇ Up to 95%@5V@2A efficiency with

- ◇ synchronous switching
- ◇ Support line compensate
- **Battery level display**
 - ◇ Support 4 LED battery level indicator
- **Others**
 - ◇ Support auto detect of plug in and out
 - ◇ Fast charge status indicator
 - ◇ Enter standby mode automatically in light load
 - ◇ Support Battery NTC
 - ◇ Integrated torch-light driver
 - ◇ Support I2C interface
- **Multiple protection,high reliability**
 - ◇ Inuput overvoltage and undervoltage protection
 - ◇ Output overcurrent,overvoltage and short circuit protection
 - ◇ Battery overcharge,over discharge and overcurrent protection
 - ◇ Over temperature protection
 - ◇ Input / Output battery temperature protection
 - ◇ 4kV ESD
- **Low BOM cost**
 - ◇ Integrated switch power MOSFET
 - ◇ Single inductor for charging and discharging
- **Package size: 6mm x 6mm 0.5pitch QFN40**

2 Applications

- **Power Bank, Portable Charger**
- **Smart Phones, Tablets and Portable devices**

3 Description

IP5355 is a power management SOC. It integrates QC2.0/ QC3.0/SCP output fast charging protocol, FCP/ AFC input and output fast charging protocol, USB C/PD2.0/PD3.0 input and output protocol, USB C PD3.0 PPS output protocol, and BC1.2/Apple/ Samsung mobile phone charging protocol. It integrates the functions of synchronous up / down converter, lithium battery charging management, battery power indication, etc. to provide a complete power solution for fast charging mobile power bank. Any single USB port can support fast charging. When two or more output ports are used at the same time, only 5V is supported.

Only one inductor is needed to realize the function of buck and boost, and only a few peripheral devices are needed in the application, which effectively reduces the size of the overall PCB and reduces the cost of BOM.

The synchronous switch boost system of IP5355 can provide the maximum output capacity of 22.5W(10V@2.25A). When boost has no load, it will automatically enter the sleep mode.

IP5355 charger provides 18W charging power and charging current up to 5.0A. Built in IC temperature, battery temperature and input voltage control loop, intelligent regulation of charging current.

IP5355 supports 4LED battery level indicator. IP5355 supports lightning function and supports buttons.

IP5355 supports I2C control interface.

Contents

1 Features	1
2 Applications	1
3 Description	2
4 Reversion History	4
5 Simplified Application	5
6 IP Series Products List.....	6
6.1 Power Bank IC	6
6.2 IP5355 Common Customized Model Description.....	7
7 Pin Configuration and Functions	8
7.1 IP5355 Pin Functions.....	8
8 Functional Block Diagram	10
9 Absolute Maximum Ratings.....	10
10 Recommended Operating Conditions.....	11
11 Electrical Characteristics	11
12 Function Description	14
12.1 Low power lock out and activation.....	14
12.2 Charge	14
12.3 Boost	14
12.4 USB C	17
12.5 USB C PD	19
12.6 Fast Charge Protocol.....	19
12.7 Charge and Discharge Path Management	20
12.8 Automatic Detection of Mobile Phone.....	22
12.9 KEY	22
12.10 Fast Charge State Indication	22
12.11 Selection of Battery Charge Discharge Curve.....	22
12.12 Battery Level Display	23
12.13 VSET (Battery voltage selection)	24
12.14 NTC function	26
12.15 I2C.....	27
13 PCB Layout	28
13.1 Location of VOUT / VBUS1 / VBUS2 capacitor.....	28
13.2 Location of VSYS capacitor	28
13.3 Location of BAT/NTC capacitor	29
14 Typical Application Diagram	30
14.1 IP5355_ABCC.....	30
15 Package.....	32
15.1 Package of the Chip.....	32
15.2 Marking Description	33
16 IMPORTANT NOTICE.....	34

4 Reversion History

NOTE: Page numbers for previous revisions may differ from page numbers in the current version.

First Release V1.00 (August 2022)

Page

-
- First release.....1
-

Changes from Reversion 1.00 to Reversion V1.10 (June 2024)

Page

- Updated model.....7
 - Added IN5819 to schematic diagram.....30
-

5 Simplified Application

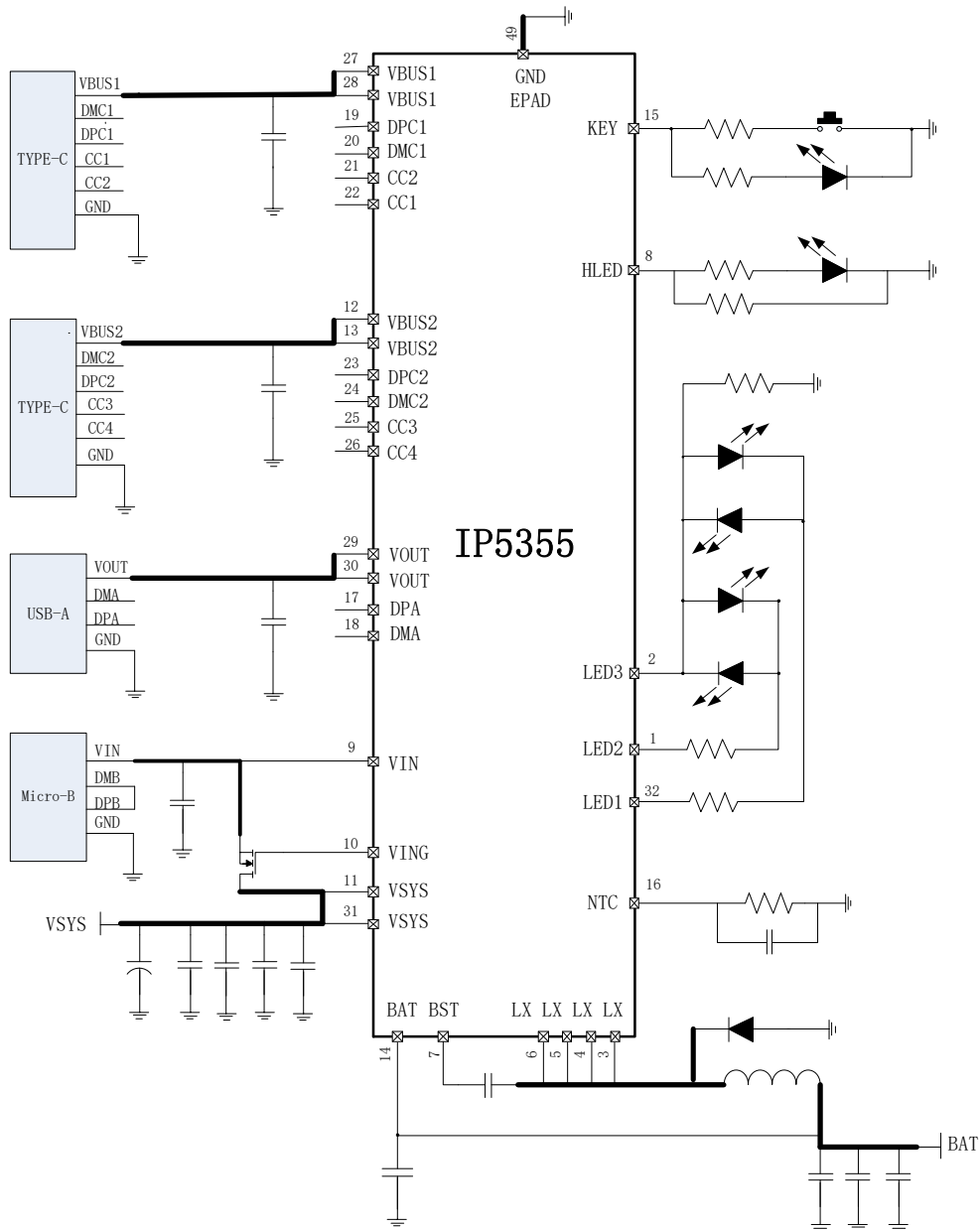

Figure 1 Simplified Application

6 IP Series Products List

6.1 Power Bank IC

IC Part No.	Charge/Boost Power		Main feature								Package	
	Boost Power	Charge Power	LED number	I2C	DCP	USB C	QC	PD3.0 /PPS	Super charge	UF CS	Package	Compatibility
IP5303T	5V/1A	5V/1A	1,2	-	-	-	-	-	-	-	ESOP8	PIN2PIN
IP5305T	5V/1A	5V/1A	1,2,3,4	√	-	-	-	-	-	-	ESOP8	
IP5306	5V/2.4A	5V/2A	1,2,3,4	√	-	-	-	-	-	-	ESOP8	
IP5306H	5V/2.4A	5V/2A	1,2,3,4	√	-	-	-	-	-	-	ESOP8	
IP5306P	5V/2.1A	5V/2A	1,2,4	√	-	-	-	-	-	-	ESOP8	
IP5316	5V/2.4A	5V/2.4A	1,2,4	√	√	√	-	-	-	-	ESSOP10	
IP5326	5V/2.4A	5V/2.4A	1,2,4	√	√	√	-	-	-	-	QFN16	
IP5407	5V/2.4A	5V/2A	1,2,4	-	√	-	-	-	-	-	ESOP8	
IP5407H	5V/2.4A	5V/2.1A	1,2,4	-	√	-	-	-	-	-	ESOP8	
IP5209	5V/2.4A	5V/2.1A	3,4,5	√	√	-	-	-	-	-	QFN24	
IP5189T	5V/2.1A	5V/2A	1,2,3,4	√	√	-	-	-	-	-	QFN24	
IP5218	5V/1A	5V/1A	1,2,3,4	-	-	√	-	-	-	-	QFN16	
IP5219	5V/2.4A	5V/2A	1,2,3,4	√	-	√	-	-	-	-	QFN24	
IP5310	5V/3.1A	5V/2.6A	1,2,3,4	√	√	√	-	-	-	-	QFN32	
IP5506	5V/2.4A	5V/2A	Nixie Tube	-	-	-	-	-	-	-	ESOP16	
IP5508	5V/2.4A	5V/2A	Nixie Tube	-	√	-	-	-	-	-	QFN32	
IP5320	5V/3.1A	5V/2.6A	Nixie Tube	√	√	√	-	-	-	-	QFN28	
IP5330	5V/3.1A	5V/2.6A	Nixie Tube	-	√	√	-	-	-	-	QFN32	
IP5328P	20W	18W	1,2,3,4	√	√	√	√	√	-	-	QFN40	
IP5353	22.5W	18W	4	√	√	√	√	√	√	-	QFN32	
IP5355	22.5W	18W	4	√	√	Double Lines	√	√	√	-	QFN32	
IP5356	22.5W	18W	Nixie Tube	√	√	Double Lines	√	√	√	-	QFN40	PIN2PIN
IP5356H	22.5W	18W	Nixie Tube	√	√	Double Lines	√	√	√	-	QFN40	
IP5356M	22.5W	18W	Nixie Tube	√	√	Double Lines	√	√	√	-	QFN40	
IP5365	22.5W	18W	Nixie Tube	√	√	Double Lines	√	√	√	√	QFN48	
IP5358	22.5W	18W	Nixie Tube	-	√	√	√	√	√	-	QFN48	
IP5561	22.5W	18W	Nixie Tube	√	√	√	√	√	√	-	QFN48	
IP5568	22.5W	18W	Nixie Tube	-	√	√	√	√	√	-	QFN64	
IP5568U	22.5W	18W	Nixie Tube	-	√	√	√	√	√	-	QFN64	
IP5385	65W	65W	Nixie Tube	√	√	Double Lines	√	√	√	√	QFN48	
IP5386	45W	45W	Nixie Tube	√	√	Double Lines	√	√	√	-	QFN48	
IP5389	100W	100W	Nixie Tube	√	√	Double Lines	√	√	√	-	QFN64	
IP5389H	100W	100W	Nixie Tube	√	√	Double Lines	√	√	√	-	QFN64	

6.2 IP5355 Common Customized Model Description

IC Part No.	Function description
IP5355_ABCC_DB	Support ABCC USB port
IP5355_I2C_ABCC_DB	Configured as I2C function, support ABCC USB port

7 Pin Configuration and Functions

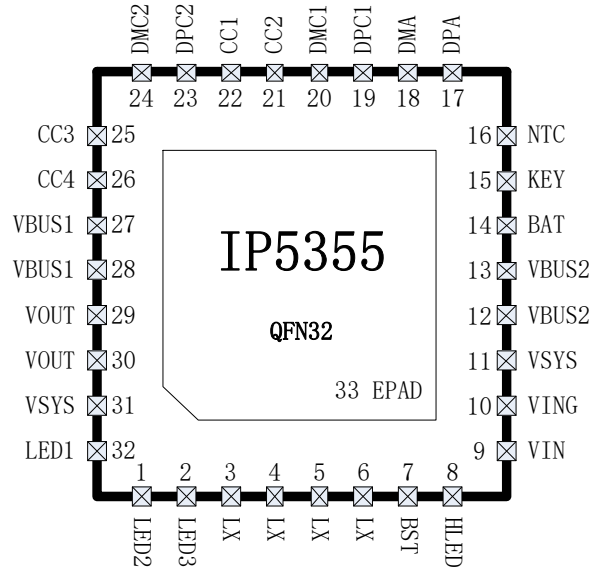

Figure 2 IP5355 Top View

7.1 IP5355 Pin Functions

PIN Num	PIN Name	PIN description
1	LED2	Battery level display drive pin LED2; I2C SDA
2	LED3	Battery level display drive pin LED3; reused as VSET and I2C INT functions
3、4、5、6	LX	DCDC switch node, connect to inductor
7	BST	Internal high voltage drive, serial capacitor to LX
8	HLED	Fast charge mode indicator
9	VIN	VIN power pin
10	VING	Used to control input path NMOS of VIN port
11、31	VSYS	Public Node of system power input and output
12、13	VBUS2	VBUS2 port power pin
14	BAT	Battery supply pin
15	KEY	Key detect pin, reused as WLED torch light function.
16	NTC	NTC PIN
17	DPA	VOUT port DP pin
18	DMA	VOUT port DM pin
19	DPC1	VBUS1 port DP pin
20	DMC1	VBUS1 port DM pin

21	CC2	VBUS1 CC2 pin
22	CC1	VBUS1 CC1 pin
23	DPC2	VBUS2 port DP pin
24	DMC2	VBUS2 port DM pin
25	CC3	VBUS2 CC3 pin
26	CC4	VBUS2 CC4 pin
27、28	VBUS1	VBUS1 port power pin
29、30	VOUT	VOUT output port power pin
32	LED1	Battery level display drive pin LED1; I2C SCK
33 (EPAD)	GND	GROUND

8 Functional Block Diagram

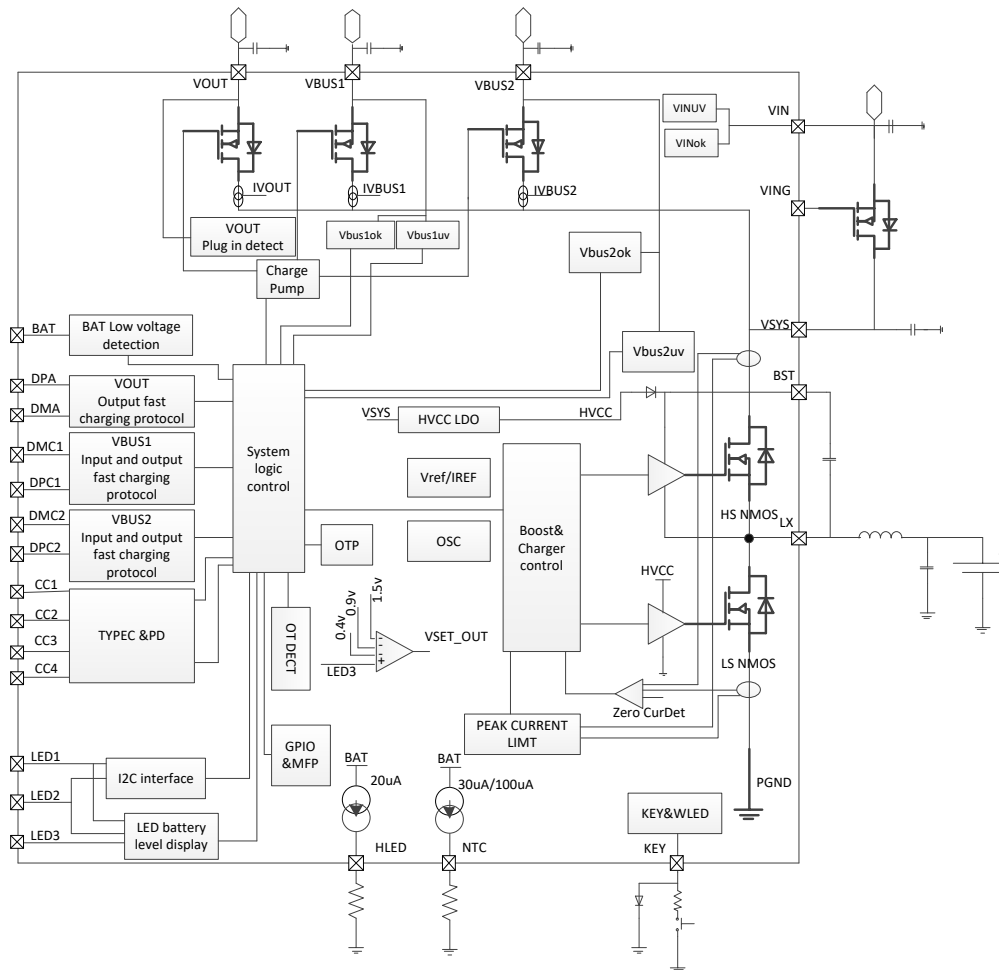

Figure 3 Functional Block Diagram

9 Absolute Maximum Ratings

Parameters	Symbol	Value	Unit
Input Voltage Range	V_{IN}, V_{BUS}	-0.3 ~ 16	V
Junction Temperature Range	T_J	-40 ~ 150	°C
Storage Temperature Range	T_{stg}	-60 ~ 150	°C
Thermal Resistance (Junction to Ambient)	θ_{JA}	35	°C / W
ESD (Human Body Model)	ESD	4	KV

*Stresses beyond those listed under Absolute Maximum Ratings may cause permanent damage to the device.

Exposure to Absolute Maximum Rated conditions for extended periods may affect device reliability.

10 Recommended Operating Conditions

Parameter	Symbol	Min.	Typ.	Max.	Unit
Input Voltage	V_{IN}, V_{BUS}	4.5	5 / 9 / 12	13.0	V
Battery Voltage	Vbat	3.0	3.7	4.4	V

*Devices' performance cannot be guaranteed when working beyond those Recommended Operating Conditions.

11 Electrical Characteristics

Unless otherwise specified, $T_A=25^{\circ}\text{C}$, $L=2.2\mu\text{H}$, $V_{BAT}=3.8\text{V}$

Parameter	Symbol	Test Conditions	Min.	Typ.	Max.	Unit
Charging System						
Input voltage	V_{BUS} / V_{IN}		4.5	5/9/12	13	V
Input Voltage Over	V_{BUS} / V_{IN}		13.0	13.5	14.0	V
Constant Charge Voltage	V_{TRGT}	4.20V	4.18	4.22	4.25	V
		4.30V	4.28	4.32	4.35	V
		4.35V	4.33	4.37	4.39	V
		4.40V	4.38	4.42	4.45	V
Charge Current	I_{CHRG}	$V_{IN}=5\text{V}$, battery current	2.0	2.4	2.8	A
		$V_{IN}=9\text{V}/12\text{V}$, battery current	3.5	4.2	5.0	A
		$V_{BUS}=5\text{V}$, input current	2.2	2.5	2.8	A
		$V_{BUS}=9\text{V}$, input current	1.7	2.0	2.3	A
		$V_{BUS}=12\text{V}$, input current	1.3	1.5	1.7	A
Trickle Charge Current	I_{TRKL}	$V_{IN}=5\text{V}$, $BAT=2.0\text{V}$, input current	50	75	100	mA
		$V_{IN}=5\text{V}$, $BAT=2.8\text{V}$, input current	100	200	350	mA
Trickle Charge Stop Voltage	V_{TRKL}		2.9	3.0	3.1	V
Charge Stop Current	I_{STOP}		250	400	550	mA
Recharge Voltage Threshold	V_{RCH}		4.05	4.10	4.15	V
Charge Safety	T_{END}		20	24	27	Hour

Time						
Boost System						
Battery operation voltage	V_{BAT}		3.0		4.4	V
DC output voltage	QC2.0 V_{OUT}	$V_{OUT}=5V@1A$	4.95	5.05	5.15	V
		$V_{OUT}=9V@1A$	8.90	9.10	9.30	V
		$V_{OUT}=12V@1A$	11.90	12.10	12.30	V
	QC3.0 V_{OUT}	@1A	4.95		12.45	V
	QC3.0 Step			200		mV
Output voltage ripple	ΔV_{OUT}	$V_{BAT}=3.7V, V_{OUT}=5.0V, fs=350kHz$		100		mV
		$V_{BAT}=3.7V, V_{OUT}=9.0V, fs=350kHz$		150		mV
		$V_{BAT}=3.7V, V_{OUT}=12.0V, fs=350kHz$		200		mV
Boost output current	I_{out}	$V_{OUT}=5V$		3.1		A
		$V_{OUT}=9V$		2.22		A
		$V_{OUT}=12V$		1.67		A
Boost efficiency	η_{out}	$V_{BAT}=3.7V, V_{OUT}=5V, I_{OUT}=2A$		94		%
		$V_{BAT}=3.7V, V_{OUT}=9V, I_{OUT}=2A$		93		%
		$V_{BAT}=3.7V, V_{OUT}=12V, I_{OUT}=1.5A$		92		%
Boost overcurrent shut down threshold	I_{shut}	$V_{BAT}=3.7V, V_{OUT}=5V$	3.4	4.0	4.4	A
		$V_{BAT}=3.7V, V_{OUT}=9V$	2.25	2.60	2.90	A
		$V_{BAT}=3.7V, V_{OUT}=12V$	1.7	1.9	2.2	A
Output light load shutdown current	I_{load}	$V_{BAT}=3.7V$		80		mA
Load overcurrent detect time	T_{UVD}	Duration of output voltage under 4.2V		30		ms
Load short circuit detect time	T_{OCD}	Duration of output current above 4.4A	150		200	μs
Control System						
Switch frequency	fs	Discharge switch frequency	300	350	400	kHz
		Charge switch frequency	300	350	400	kHz
NMOS on resistance	r_{DSON}	Upper NMOS		9	11	m Ω

NMOS on resistance		Lower NMOS		9	11	mΩ
Battery port standby current	I_{STB}	$V_{IN}=0V$, $V_{BAT}=3.7V$, average current		100		μA
LED light driving current	I_{WLED}	Voltage decrease 10%	10	15	20	mA
LED display driving current	I_{L1} I_{L2} I_{L3}			3		mA
Total load Light load shut down detect time	T_{1load}	The load current is consistently less than 80mA	25	32	44	s
Output port light load shut down detect time	T_{2load}		14	16	18	s
Short press on key wake up time	$T_{OnDebounce}$		60	100	200	ms
Time of WLED turn on	$T_{Keylight}$		1.2	2	3	s
Thermal shut down temperature	T_{OTP}	Rising temperature	130	140	150	°C
Thermal shut down hysteresis	ΔT_{OTP}			40		°C

12 Function Description

12.1 Low power lock out and activation

The first time IP5355 access to the battery, IC is in lock out state, battery level indicator LED will flash 5s; Under non-charging state, if the battery voltage is too low to trigger the low power shutdown, IP5355 will enter lock out state too.

In low battery state, to decrease the quiescent power, IP5355 do not support plug in detect function or key press activation function. During which, key press action will not trigger boost output, and battery level indicator LED will flash 5s.

Under the lock out state, only by entering charging status can activate IP5355 's full function.

12.2 Charge

IP5355 integrated a constant current and constant voltage Li battery charging management system with synchronous switch, adaptive to various charging voltage.

When the battery voltage is lower than 3V, trickle charging less than 200mA charging current is applied;

when the battery voltage is higher than 3V, enters constant current charging stage, the maximum charging current at battery port is 5.0A; During 5V input voltage, maximum input power is 10W; During the fast charging state, maximum input power is 18W. The highest charging current is up to 5.0A, charging efficiency can be up to 94%, such can reduce 3 / 4 charging time.

when the battery voltage is near the preset battery voltage, enters constant voltage charging stage; when the charging current is less than 400mA and battery voltage is near the constant voltage charging stage, the charging process is stopped. When the charging stage is accomplished, once the battery voltage falls under 4.1V, battery charging stage will be restarted.

IP5355 supports charging the battery and phone at the same time, output voltage is 5V.

12.3 Boost

IP5355 Integrated a synchronized switch converter which supports high voltage output, providing 3.3V ~ 12V output voltage output, load capacity can be: 5V@3.1A, 9V@2.22A and 12V@1.67A. 350kHz switching frequency. Internal soft start function. In avoid of large rush current causing device failure at start up stage, built-in overcurrent, short circuit, overvoltage and over temperature protection function, make insurance of the stability and reliability of power system.

Boost system output current can be auto-modulated according to the temperature, ensuring the IC is under the preset temperature.

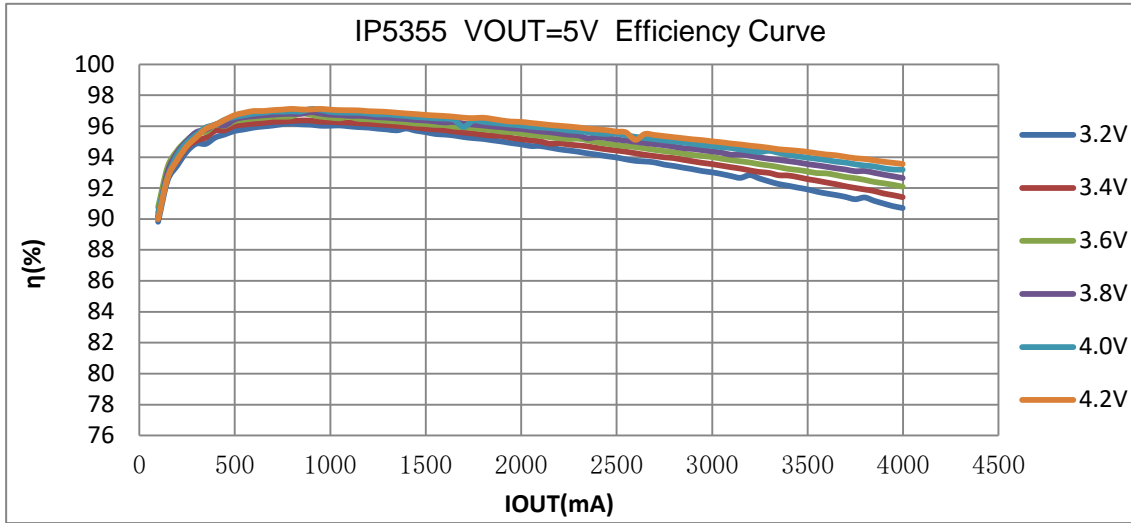

Figure 4 IP5355 VOUT=5V Efficiency Curve

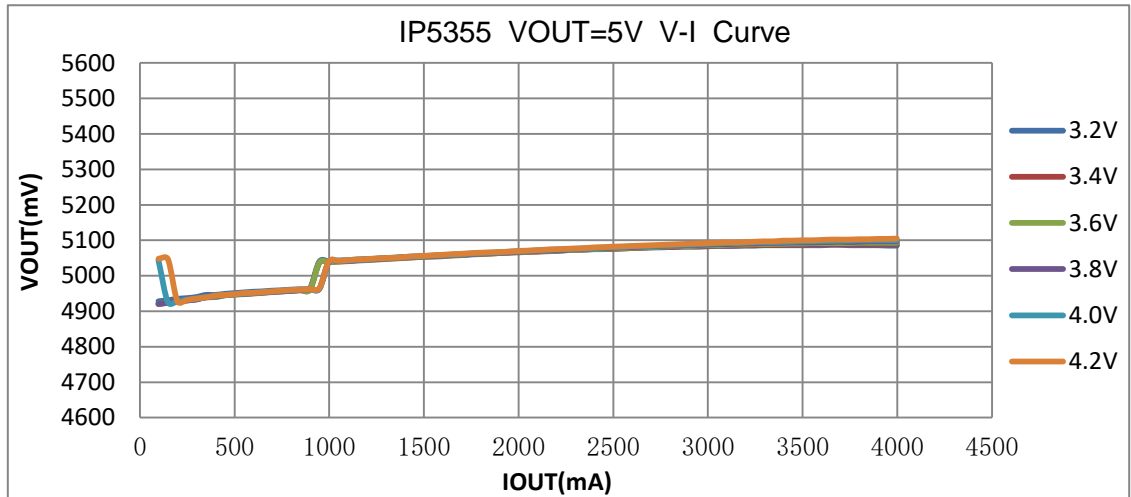

Figure 5 IP5355 VOUT=5V V-I Curve

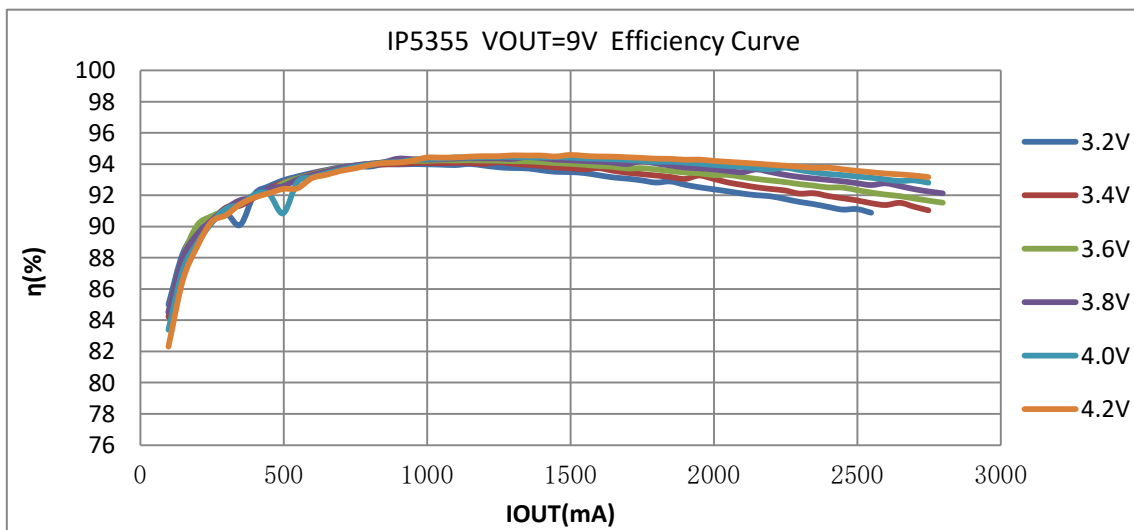

Figure 6 IP5355 VOUT=9V Efficiency Curve

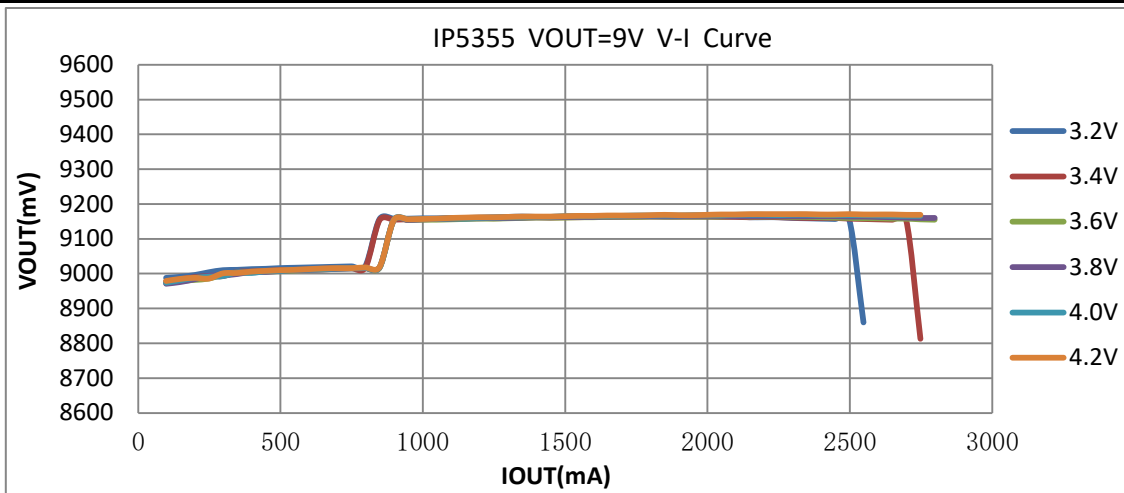

Figure 7 IP5355 VOUT=9V V-I Curve

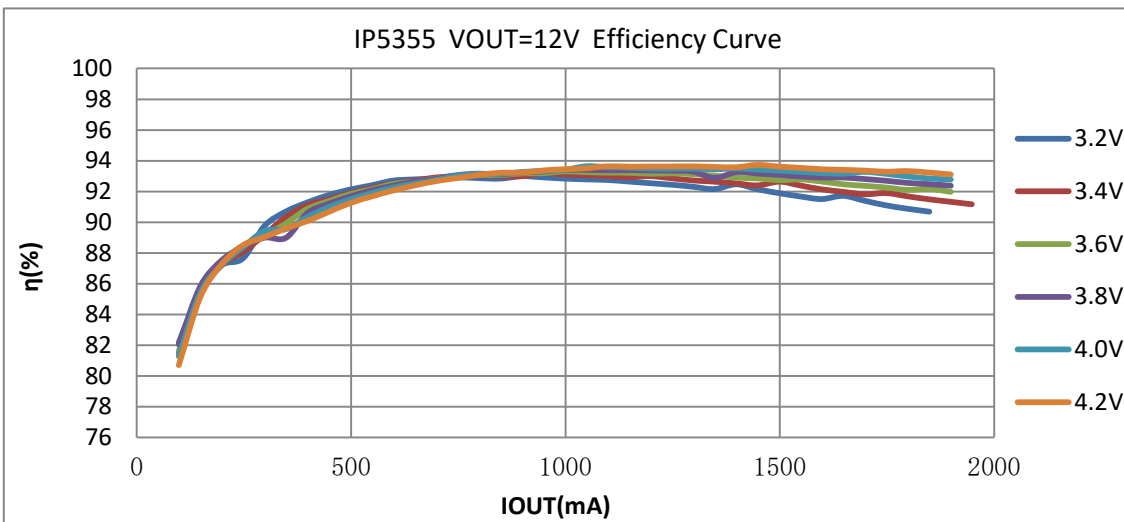

Figure 8 IP5355 VOUT=12V Efficiency Curve

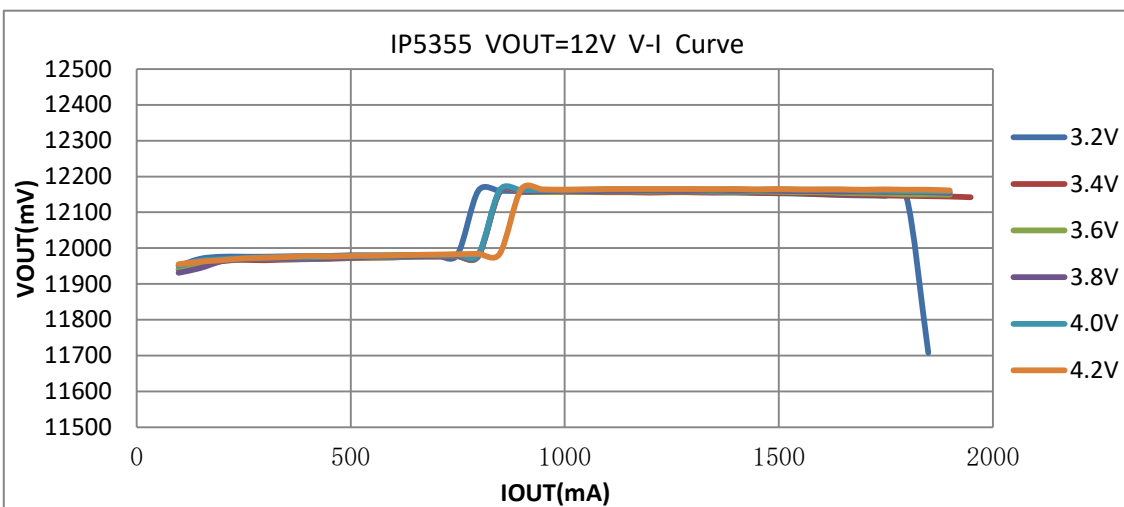

Figure 9 IP5355 VOUT=12V V-I Curve

12.4 USB C

IP5355 integrated USB C DRP port, auto-switching the internal pull-up and pull-down circuit on CC1 and CC2 by distinguishing the role of the attached device. Support Try.SRC function, when the attached device is also DRP device, IP5355 will supply power for the opposite device.

When worked as DFP, the output current can be set as three levels; when worked as UFP, the current capability from the opposite device can be detected.

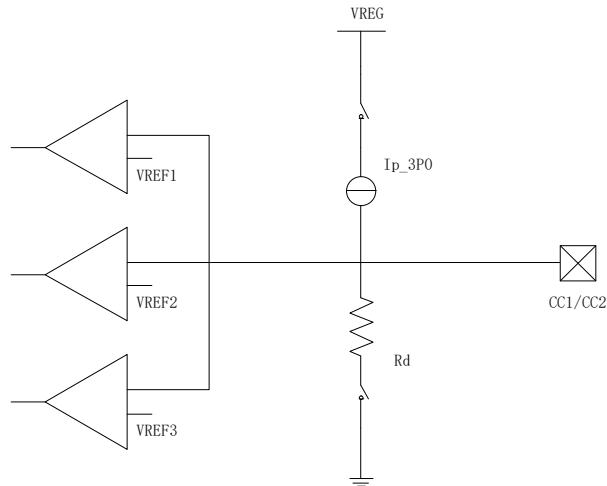

Figure 10 CC internal circuit

Table 1 Pull-up and pull-down ability

Name	Value
Ip_3P0	330 μ A
Rd	5.1k Ω

Table 2 Comparator Threshold of pull-up Ip

	Minimum Voltage	Maximum Voltage	Threshold
Powered cable/adapter (vRa)	0.00V	0.75V	0.80V
Sink (vRd)	0.85V	2.45V	2.60V
No connect(vOPEN)	2.75V		

Table 3 Comparator Threshold of Pull-down Resistor Rd

Detection	Min voltage	Max voltage	Threshold
vRa	-0.25V	0.15V	0.20V
vRd-Connect	0.25V	2.04V	
vRd-USB	0.25V	0.61V	0.66V
vRd-1.5	0.70V	1.16V	1.23V
vRd-3.0	1.31V	2.04V	

Figure 4-36 DRP Timing

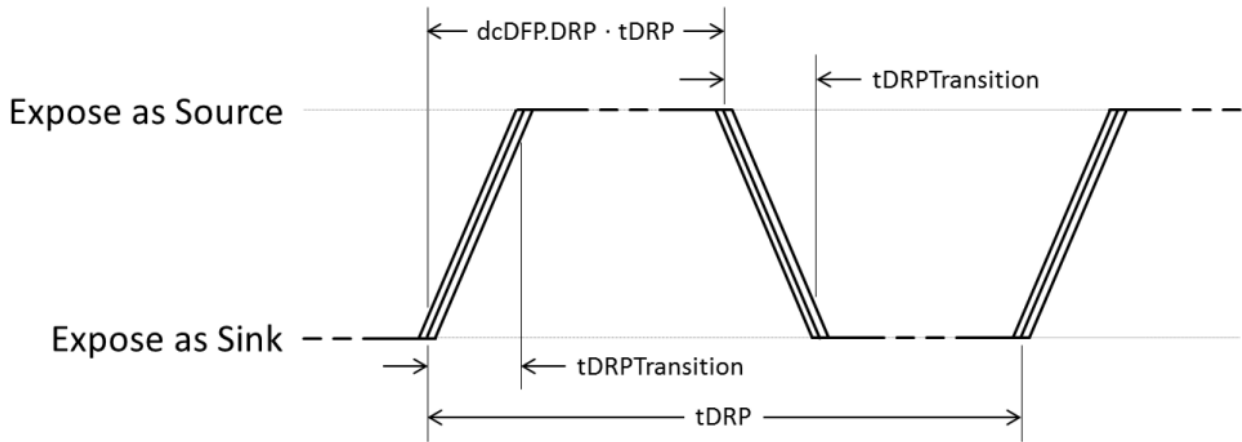

Figure 11 USB C detects cycle

Table 4 USB C detects cycle

	Minimum	Maximum	Description
tDRP	50ms	100ms	The period a DRP shall complete a Source to Sink and back advertisement
dcSRC.DRP	30%	70%	The percent of time that a DRP shall advertise Source during tDRP
tDRPTransition	0ms	1ms	The time a DRP shall complete transitions between Source and Sink roles during role resolution
tDRPTry	75ms	150ms	Wait time associated with the Try.SRC state
tDRPTryWait	400ms	800ms	Wait time associated with the Try.SNK state

charge type and request on DP, DM, which support fast charge for devices of QC2.0/QC3.0、FCP、AFC and Apple 2.4A mode, Samsung 2.0A mode and BC1.2 1.0A mode.

For Apple 2.4A mode: DP=DM=2.7V

For Samsung 2.0A mode: DP=DM=1.2V

For BC1.2 1.0A mode: DP short to DM

Under BC1.2 mode, when the DP voltage is detected in the range of 2V ~ 0.325V for 1.25s, fast charge will be initially determined, then the short status between DP and DM will be disconnected, and DM pull-down 20kOhm to GND at the same time. After which, if in the following 2ms the DP voltage is in range of 2V ~ 0.325V and DM lower than 0.325V, fast charge handshake is accomplished successfully. Then QC2.0/QC3.0 device can request for desired voltage according to the QC standards. Any time DP lower than 0.325V will force to exit the fast charge mode, the output voltage will fall back to default 5V.

Table 5 QC2.0/QC3.0 output voltage request rule

DP	DM	Result
0.6V	GND	5V
3.3V	0.6V	9V
0.6V	0.6V	12V
0.6V	3.3V	Continue Mode
3.3V	3.3V	Hold

Continuous mode is supported by QC3.0, voltage can be adjusted by 0.2V / step according to QC3.0 request under the continues mode.

Table 6 Fast charging protocol supported by each port of IP5355

protocols	VOUT output	VBUS1 output	VBUS1 input	VBUS2 output	VBUS2 input	VIN input
QC2.0	√	√	-	√	-	-
QC3.0	√	√	-	√	-	-
AFC	√	√	√	√	√	-
FCP	√	√	√	√	√	-
SCP	√	√	√	√	√	-
PD2.0	-	√	√	√	√	-
PD3.0	-	√	√	√	√	-
PPS	-	√	-	√	-	-

supported: √

not supported: -

12.7 Charge and Discharge Path Management

Standby:

If VIN or VBUS is attached, IP5355 will start the charging process directly.

If USB C UFP device is attached on VBUS or sink device is attached on VOUT port, IP5355 will start discharge function automatically.

If key is pressed, the VOUT, VBUS1 and VBUS2 port will open only when load is detected on the according port, or the output on these port will be closed.

Discharge:

In the case of no key action, only the output path of the output port plugged in the electrical equipment will be opened; the output path of the output port not connected to the equipment will not be opened. When the output current of the opened output port is less than about 80mA, it will automatically close after a period of time.

Any port of VOUT, VBUS1 and VBUS2 can support the output fast charging protocol. However, since this application is a single inductance application, it can only support one voltage output, so it can only support the fast charging output when only one output port is open. When two or three outlets are used at the same time, the quick charge function will be automatically turned off.

According to the connection shown in the "typical application diagram", when any output port has entered the fast charging output mode, when the other output port is plugged in with electrical equipment, all the output ports will be closed first, the high-voltage fast charging function will be closed, and then the output ports with equipment will be opened. In this case, all the output ports only support the charging of apple, Samsung and bc1.2 modes. When the number of electrical equipment is reduced to only one, all output ports will be closed first, the high-voltage fast charging function will be turned on, and then the output port of the last electrical equipment will be turned on, so as to reactivate the equipment to request fast charging. When only one output port is open and the total output current is less than about 80mA for about 32s, the output port and discharge function will be closed and the standby mode will be entered.

Charging:

Any port of VIN port and VBUS port can be charged by inserting the power supply. If both ports are connected to the power supply for charging, the first inserted power supply will be used for charging.

In the single charging mode, the fast charging mode of the power supply will be automatically identified, and the appropriate charging voltage and current will be automatically matched

Charging and discharging at the Same Time:

When the charging power supply and the electrical equipment are plugged in at the same time, the charging and discharging mode will be automatically entered. In this mode, the chip will automatically turn off the internal fast charge input request. When the vsys voltage is only 5V, turn on the discharge path to supply power to the electrical equipment; if the vsys voltage is greater than 6.0V, for safety reasons, the discharge path will not be turned on.

In the process of charging and discharging, if the charging power is unplugged, IP5355 will turn off the charging function and restart the discharging function to supply power to the electric equipment. For the sake of safety, and in order to be able to reactivate the mobile phone to request fast charging, the voltage will drop to 0V for a period of time during the conversion process.

In the process of charging and discharging, if the electric equipment is unplugged, or the electric equipment is full and stops pumping for 16s, the corresponding discharge path will be automatically closed. When the discharge paths are closed and the state returns to single charging mode, the charging undervoltage loop will be reduced, and the fast charging will be automatically reactivated to accelerate the charging of mobile power supply.

12.8 Automatic Detection of Mobile Phone

Auto detection on sink device / phone attachment:

IP5355 support auto detection on sink device/phone attachment/plug in, once the attachment is detected, the boost will be turned on charging the sink device / phone, so non-key solution are supported.

Auto detection on sink device / phone fully charged:

When the output current of a single port is less than about 80mA and lasts for about 16s, the output port will be closed. When the total current is less than about 80mA for about 32s, it is considered that all output cell phones are full or unplugged, and the boost output will be automatically turned off.

12.9 KEY

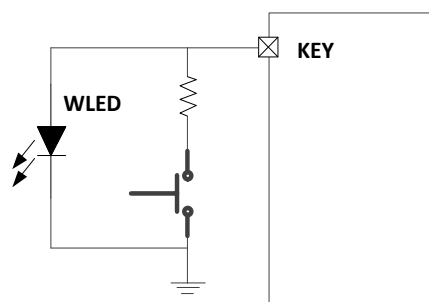

Figure 13 KEY circuit

Key circuit is illustrated in Figure 13, which can recognize short press or long press operation.

- Short press : pressed time in range of 100ms~2s: turn on the battery level display LED and BOOST output
- Long press :pressed time longer than 2s: turn on or turn off the torch light WLED
- No response on press time less than 30ms
- Two short press in 1s: turn off boost output, battery level display LED and torch light WLED
- Long 10s press will reset the whole system

12.10 Fast Charge State Indication

HLED PIN is used for indication for the present fast charge mode, either in fast charging or discharging mode, when the system enters fast charge , the light LED will turn on.

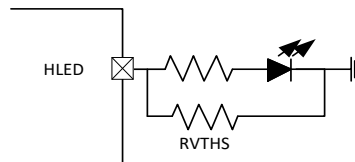

Figure 14 fast charge state indication

12.11 Selection of Battery Charge Discharge Curve

IP5355 selects different battery charging and discharging curves by pulling down the resistors with different resistance values (RVTHS) on the HLED pin. The connection mode is shown in Figure 14.

The following table lists the relationship between the state of power indicator and battery voltage

when RVTHS with different resistance values are pulled down at HLED pin;

It should be noted that the rotating lamp voltage (OCV) in the table is not the actual voltage of the battery, but the voltage after compensation of the internal resistance of the battery. The calculation formula is as follows:

During charging, turn lamp voltage (OCV) = actual battery voltage (voltage from IP5355 BAT (14th pin) to ground) - IBAT (battery terminal charging current measured by IP5355) * RSET (40mΩ);

When discharging, turn lamp voltage (OCV) = actual battery voltage (voltage from IP5355 BAT (14th pin) to ground) + IBAT (battery terminal discharge current measured by IP5355) * RSET (40mΩ);

Table 7 Charge discharge OCV threshold

	Resistance	Power Indicator Status	Battery charging and discharging voltage (4.20V)	Charge and discharge rotating lamp voltage (4.30V/4.35V/4.40V battery)
1	20kΩ 1%	4 lights to 3 lights	4020 mV	4020 mV
		3 lights to 2 lights	3780 mV	3780 mV
		2 lights to 1 lights	3600 mV	3600 mV
2	43kΩ 1%	4 lights to 3 lights	4020 mV	4020 mV
		3 lights to 2 lights	3900 mV	3900 mV
		2 lights to 1 lights	3660 mV	3660 mV
2	62kΩ 1%	4 lights to 3 lights	4020 mV	4020 mV
		3 lights to 2 lights	3900 mV	3900 mV
		2 lights to 1 lights	3780 mV	3780 mV
4	NC (Register setting)	4 lights to 3 lights	3900 mV	4020 mV
		3 lights to 2 lights	3720 mV	3900 mV
		2 lights to 1 lights	3600 mV	3720 mV

12.12 Battery Level Display

Battery level display for LED mode

IP5355 4LED battery level display solution, the connection method is as follows.

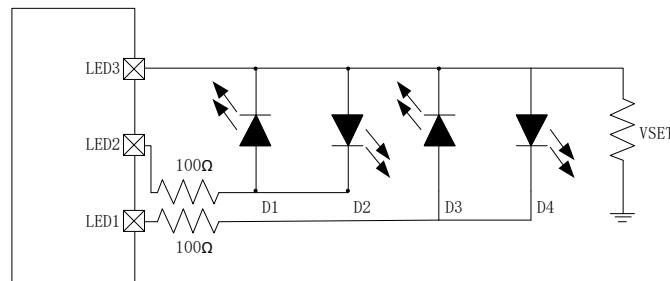

Figure 15 4LED circuits

4LED display mode:

Table 8 Charging lamp display

Battery capacity (C) (%)	D1	D2	D3	D4
Fully charged	ON	ON	ON	ON
$75\% \leq C$	ON	ON	ON	0.5Hz Flash
$50\% \leq C < 75\%$	ON	ON	0.5Hz Flash	OFF
$25\% \leq C < 50\%$	ON	0.5Hz Flash	OFF	OFF
$C < 25\%$	0.5Hz Flash	OFF	OFF	OFF

Table 9 Boost lamp display

Battery capacity (C) (%)	D1	D2	D3	D4
$C \geq 75\%$	ON	ON	ON	ON
$50\% \leq C < 75\%$	ON	ON	ON	OFF
$25\% \leq C < 50\%$	ON	ON	OFF	OFF
$3\% \leq C < 25\%$	ON	OFF	OFF	OFF
$0\% < C < 3\%$	1.0Hz Flash	OFF	OFF	OFF
$C = 0\%$	OFF	OFF	OFF	OFF

12.13 Exception Warning

The IP5355 supports abnormal light display. When abnormal conditions such as NTC high and low temperature, VIN/VBUS overvoltage, and BAT low power are triggered, the power indicator will alarm.

Table 10 exception warning

State	D1	D2	D3	D4
NTC	1.25Hz Flash	1.25Hz Flash	1.25Hz Flash	1.25Hz Flash
VIN/VBUS overvoltage	1.25Hz Flash	1.25Hz Flash	1.25Hz Flash	1.25Hz Flash
BATLOW	1.25Hz Flash 4s	OFF	OFF	OFF

12.14 VSET (Battery voltage selection)

IP5355 can set battery specifications and configure parameters of different battery specifications through VSET pin (LED3 pin). The resistance threshold of VSET and the set battery specifications are shown in the table below.

Table 10 Battery voltage selection

Resistance	Battery Type
NC	4.20V
68kΩ	4.30V

33kΩ	4.35V
10kΩ	4.40V

12.15 NTC function

IP5355 integrates NTC function, which can detect battery temperature. When IP5355 is working, NTC pin output current, and generate voltage through external NTC resistance. IC internal detects the voltage of NTC pin to determine the current battery temperature.

* The 100nF capacitance of NTC must be close to IC PIN.

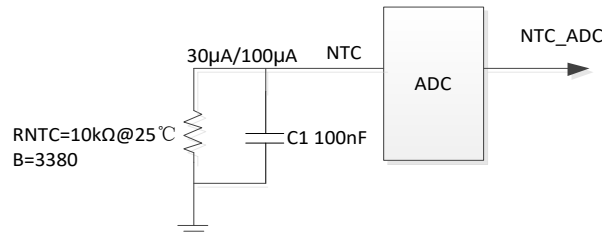

Figure 16 NTC circuit

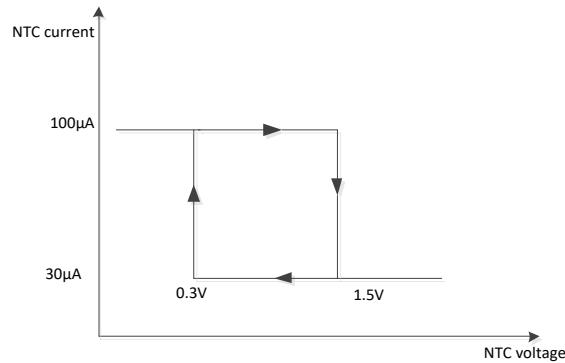

Figure 17 Relationship between NTC voltage and output current

When the NTC discharge current is 80μA, if the NTC voltage is higher than 1.5V, the current becomes 30μA;

When the NTC discharge current is 30μA, if the NTC voltage is lower than 0.3V, the current changes to 100μA.

In the state of charge:

When the NTC voltage is lower than 0.49V, it means the battery temperature is higher than 45°C, the charging is stopped.

When the NTC voltage is higher than 0.82V, it means the battery temperature is lower than 0°C, the charging is stopped.

In the state of discharge:

When the NTC voltage is lower than 0.30V, it means the battery temperature is higher than 60°C, the discharging is stopped.

When the NTC voltage is higher than 2.08V, it means the battery temperature is lower than -20°C, the discharging is stopped.

If NTC is not required in the application, 10kΩ resistance shall be connected to the ground at NTC pin, and floating or direct grounding is not allowed.

12.16 I2C

I2C connection mode

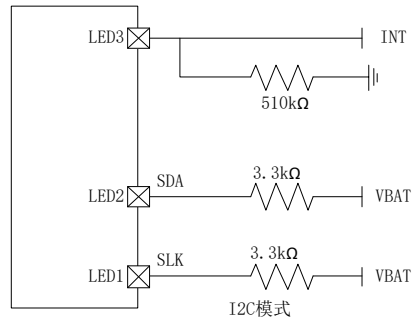

Figure 18 I2C Application method

The IP5355 does not support I2C connection by default. If the I2C connection is required, the customized IP5355_I2C_XXXX is used for design. In I2C mode, the INT signal is in high resistance state in standby mode and high level state in working state, which can be used to wake up MCU.

13 PCB Layout

Here below lists essential precautions that may affect the function and performance on PCB layout, more details will be attached in another document if any.

13.1 Location of VOUT / VBUS1 / VBUS2 capacitor

IP5355 integrated USB output power path, VOUT / VBUS1 / VBUS2 2.2 μ F capacitor must be placed close to the chip pin. If the layout allows, the closer the capacitor is to the chip, the better.

At the same time, place a 100nF capacitor close to the USB seat, and the capacitor is close to the USB seat in parallel.

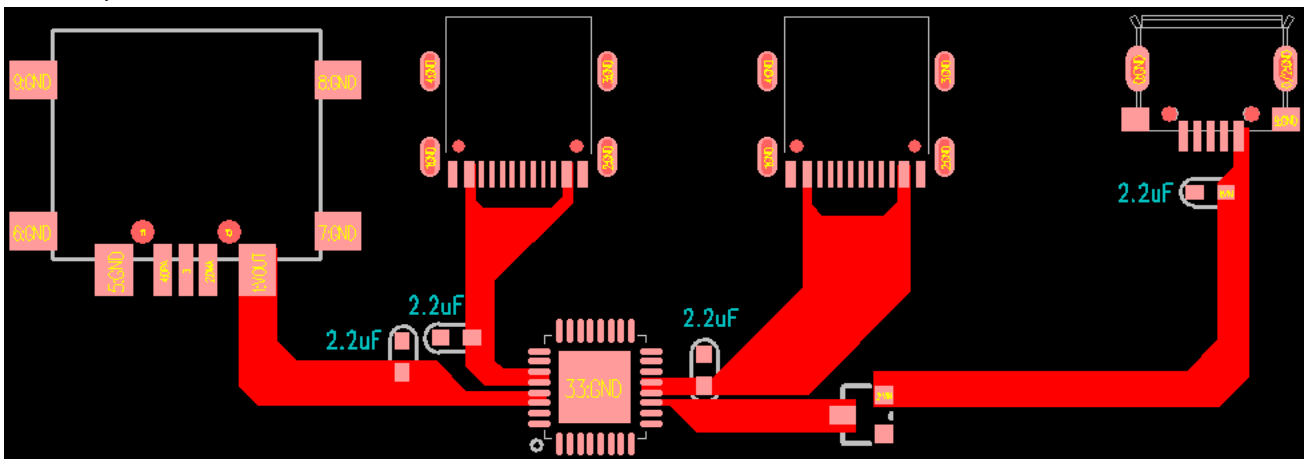

Figure 20 Output capacitance

13.2 Location of VSYS capacitor

The power and current of the chip are relatively large, and the position of the capacitor on the VSYS network will affect the stability of the DCDC. The capacitors on the VSYS network need to be as close to the VSYS pin and EPAD of the IC as possible, and copper is laid on a large area, and more vias are added to reduce the area of current loop between the capacitors and the IC and reduce parasitic parameters.

VSYS pins are distributed on both sides of the chip, and capacitors need to be placed near the pins on both sides, and the VSYS pins on both sides are connected by a wide (no less than 100mil) copper laying on the PCB.

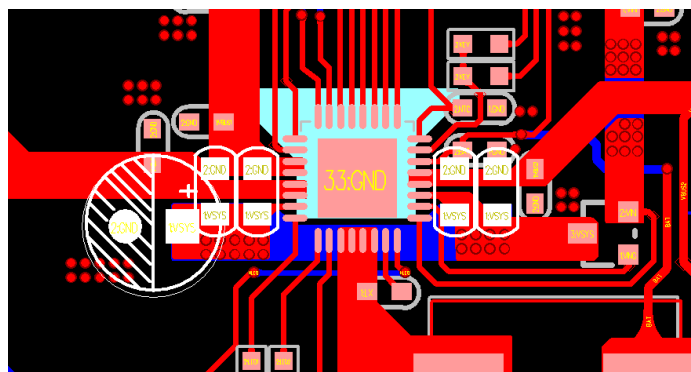

Figure 21 VSYS capacitance

13.3 Location of BAT/NTC capacitor

The filter capacitors of BAT pin and NTC pin should be placed as close as possible to the pin of the chip, and some holes should be drilled near the capacitors GND pin.

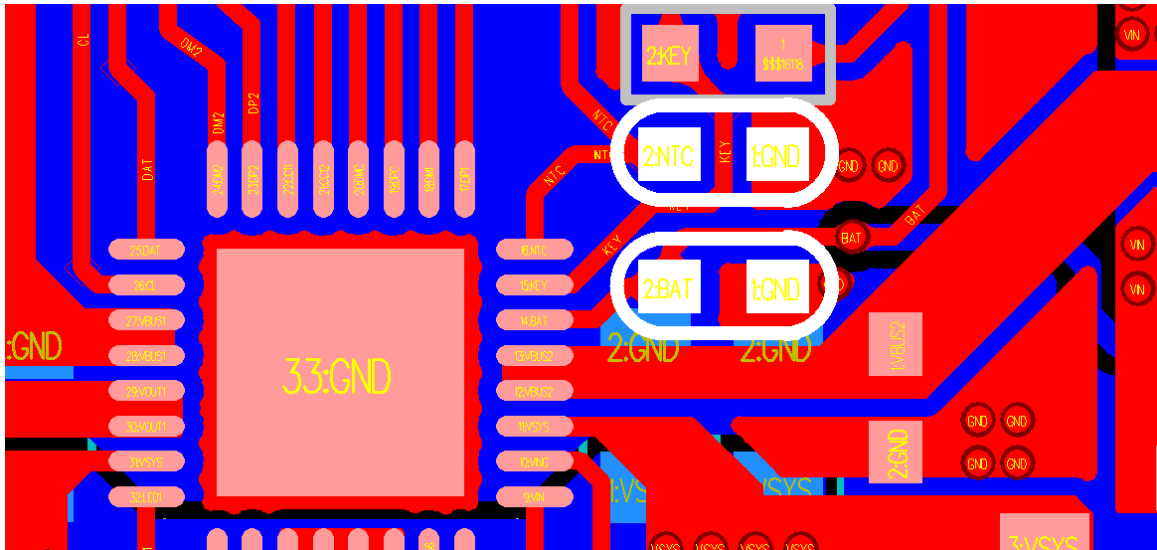

Figure 22 BAT/NTC capacitance

14 Typical Application Diagram

Total solution of fast charge power bank is merely realized by passive devices of MOSFET, inductor, capacitor and resistor.

14.1 IP5355_ABCC

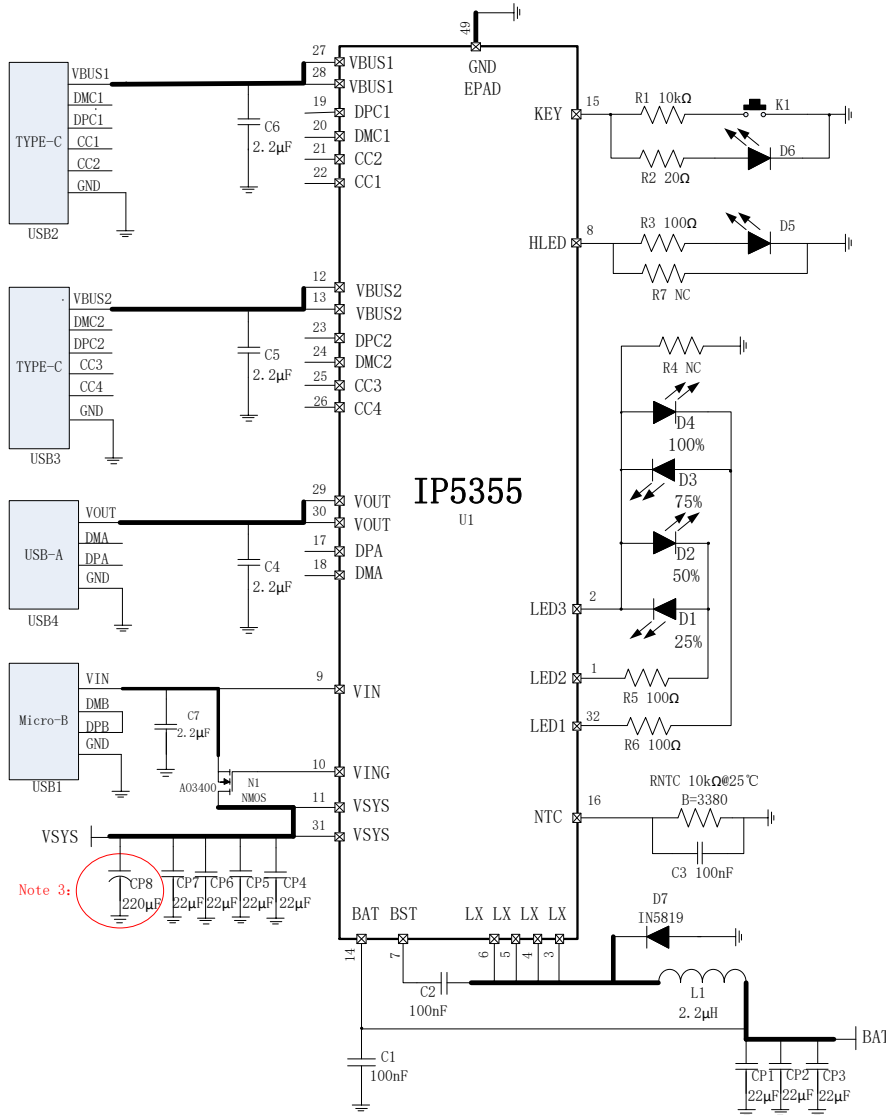

Figure 23 IP5355_ABCC application circuit

Note:

1. C3 capacitor needs to be close to NTC pin. When NTC is not used, NTC pin is grounded through 10kΩ resistance;
2. When VIN port is not required, it can be directly suspended; When VOUT ports are not required, the 2.2µF capacitor needs to be kept close to the chip pin.
3. IP5355 VSYS 220µF capacitor: VSYS capacitor needs to be close to the chip pin, if the capacitor is too far to add 220µF electrolytic capacitor. If the structure allows, we suggest adding 220µF electrolytic capacitor. If no electrolytic capacitor is added, the VSYS capacitor should be close to the chip pin.

BOM

No.	Part Name	Type	Location	Num	Note
1	SMT IC	QFN32 IP5355	U1	1	
2	SMT capacitor	0603 100nF 10% 25V	C1 C2	2	
3	SMT capacitor	0603 2.2μF 10% 25V	C4 C5 C6 C7	4	
4	SMT capacitor	0805 22μF 10% 16V	CP1 CP2 CP3	3	
5	SMT capacitor	0805 22μF 10% 25V	CP4 CP5 CP6 CP7	4	
6	capacitor	220uf 10% 25V	CP8	1	
7	SMT resistor	0603 10kΩ 1%	R1	2	
8	SMT resistor	0603 NC 1%	R4 R7	2	
9	SMT resistor	0603 100Ω 1%	R3 R5 R6	3	
10	SMT LED	0603 BLUE	D1 D2 D3 D4	4	
11	SMT LED	0603 RED	D5	1	
12	LED	5MM LED	D6	1	
13	SMT resistor	0603 20Ω 1%	R2	1	
14	NTC	10kΩ@25°C B=3380	RNTC	1	
15	SMT capacitor	0603 100nF 10% 16V	C3	1	
16	SMT NMOS	SOT23-3 AO3400	N1	1	
17	Inductor	2.2μH 10*10	L1	1	
18	KEY	SMT 3*6	K1	1	
19	OUTPUT USB	AF10 8 USB	USB4	1	
20	USB C CONNECTOR	USB C CONNECTOR	USB2 USB3	2	
21	INPUT USB	MICRO-7-DIP-5.9	USB1	1	
22	SMT Schottky	IN5819	D7	1	

Recommended inductance model

DARFON PIN	Thickness (mm)	Inductance (μH)	Tolerance	DC Resistance (mΩ)	Heat Rating Current DC Amp.	Saturation Current DC Amps.	Measuring Condition
				Max.	Idc(A)Max.	Isat(A)Max.	
SPA1040-2R2M	4.0	2.2	±20%	7.0	14.0	16.0	100kHz/1.0V

15 Package

15.1 Package of the Chip

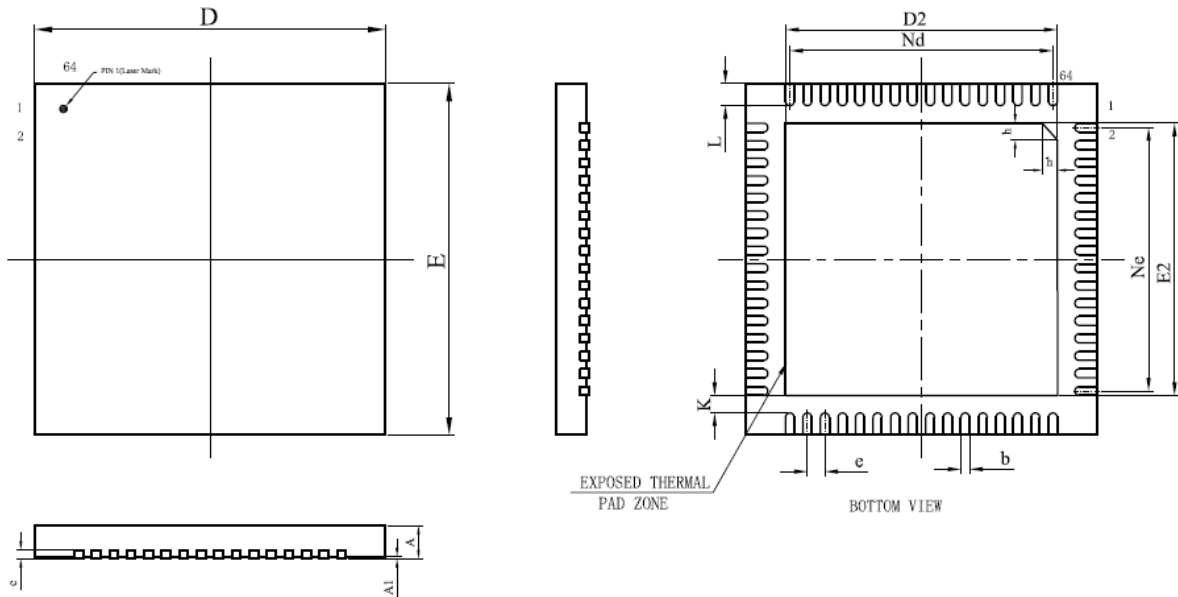

SYMBOL	MILLIMETER		
	MIN	NOM	MAX
A	0.70	0.75	0.80
A1	-	0.02	0.05
b	0.15	0.20	0.25
c	0.18	0.20	0.25
D	7.90	8.0	8.10
D2	6.10	6.20	6.30
e	0.4 BSC		
Nd	6.00BSC		
E	7.90	8.0	8.10
E2	6.10	6.20	6.30
Ne	6.00BSC		
L	0.45	0.50	0.55
K	0.20	-	-
h	0.30	0.35	0.40

15.2 Marking Description



Note:

- 1、 --Injoinic Logo
- 2、IP5355 --Part Number
- 3、XXXXXXXX --Manufacture number
- 4、○ --PIN1 location

Figure 26 Marking description

16 IMPORTANT NOTICE

INJOINIC TECHNOLOGY and its subsidiaries reserve the right to make corrections, enhancements, improvements and other changes to its semiconductor products and services. Buyers should obtain the latest relevant information before placing orders and should verify that such information is current and complete. All semiconductor products (also referred to herein as “components”) are sold subject to INJOINIC TECHNOLOGY’s terms and conditions of sale supplied at the time of order acknowledgment.

INJOINIC TECHNOLOGY assumes no liability for applications assistance or the design of Buyers’ products. Buyers are responsible for their products and applications using INJOINIC TECHNOLOGY’s components. To minimize the risks associated with Buyers’ products and applications, Buyers should provide adequate design and operating safeguards.

Buyer acknowledges and agrees that it is solely responsible for compliance with all legal, regulatory and safety-related requirements concerning its products, and any use of INJOINIC TECHNOLOGY’s components in its applications, notwithstanding any applications-related information or support that may be provided by INJOINIC TECHNOLOGY. Buyer represents and agrees that it has all the necessary expertise to create and implement safeguards which anticipate dangerous consequences of failures, monitor failures and their consequences, lessen the likelihood of failures that might cause harm and take appropriate remedial actions. Buyer will fully indemnify INJOINIC TECHNOLOGY and its representatives against any damages arising out of the use of any INJOINIC TECHNOLOGY’s components in safety-critical applications.

Reproduction of significant portions of INJOINIC TECHNOLOGY’s information in INJOINIC TECHNOLOGY’s data books or data sheets is permissible only if reproduction is without alteration and is accompanied by all associated warranties, conditions, limitations, and notices. INJOINIC TECHNOLOGY is not responsible or liable for such altered documentation. Information of third parties may be subject to additional restrictions.

INJOINIC TECHNOLOGY will update this document from time to time. The actual parameters of the product may vary due to different models or other items. This document voids all express and any implied warranties.

Resale of INJOINIC TECHNOLOGY’s components or services with statements different from or beyond the parameters stated by INJOINIC TECHNOLOGY for that component or service voids all express and any implied warranties for the associated INJOINIC TECHNOLOGY’s component or service and is an unfair and deceptive business practice. INJOINIC TECHNOLOGY is not responsible or liable for any such statements.