

IPS1031(S)(R)

INTELLIGENT POWER LOW SIDE SWITCH

Features

- Over temperature shutdown
- Over current shutdown
- Active clamp
- Low current & logic level input
- ESD protection
- Optimized Turn On/Off for EMI
- Diagnostic on the input current

Description

The IPS1031(S)(R) is a three terminal Intelligent Power Switch (IPS) that features a low side MOSFET with over-current, over-temperature, ESD protection and drain to source active clamp. This device offers protections and the high reliability required in harsh environments. The switch provides efficient protection by turning OFF the power MOSFET when the temperature exceeds 165°C or when the drain current reaches 18A. The device restarts once the input is cycled. A serial resistance connected to the input provides the diagnostic. The avalanche capability is significantly enhanced by the active clamp and covers most inductive load demagnetizations.

Product Summary

Rds(on)	50mΩ (max.)
Vclamp	36V
Ishutdown	18A (typ.)

Packages

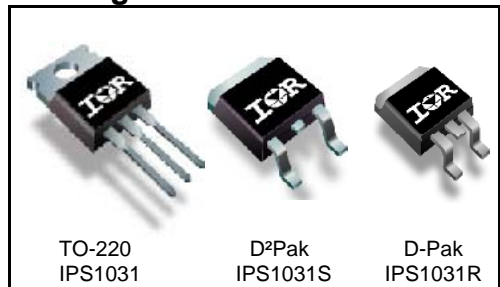

Typical Connection

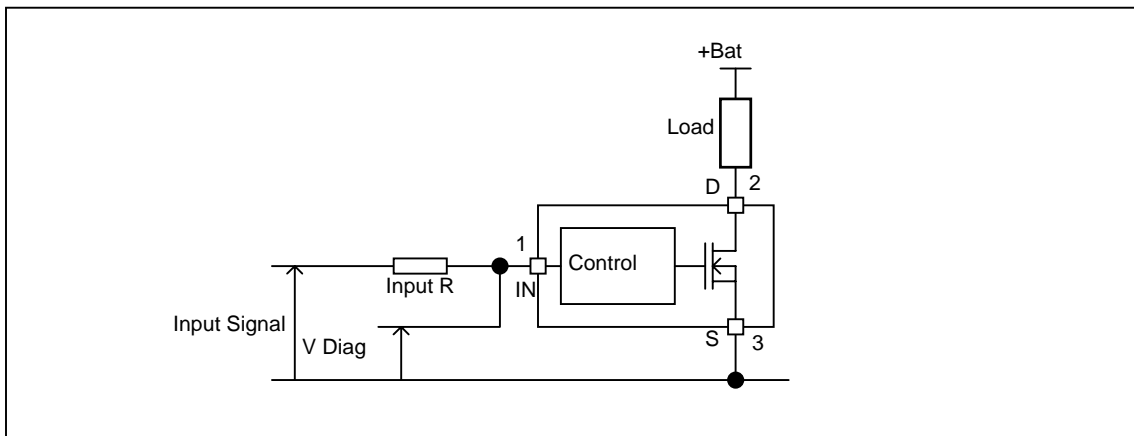

Absolute Maximum Ratings

Absolute maximum ratings indicate sustained limits beyond which damage to the device may occur. All voltage parameters are referenced to Ground lead. (Tambient=25°C unless otherwise specified).

Symbol	Parameter	Min.	Max.	Units
Vds	Maximum drain to source voltage	-0.3	36	V
Vds cont.	Maximum continuous drain to source voltage	-	28	V
Vin	Maximum input voltage	-0.3	6	V
Isd cont.	Max. diode continuous current (limited by thermal dissipation)	—	4	A
Pd	Maximum power dissipation (internally limited by thermal protection)			
	Rth=5°C/W IPS1031	—	25	W
	Rth=40°C/W IPS1031S 1" sqr. footprint	—	3.1	
	Rth=50C/W IPS1031R 1" sqr. footprint	—	2.5	
ESD	Electrostatic discharge voltage (Human body) C=100pF, R=1500Ω			
	Between drain and source	—	4	kV
	Other combinations	—	3	
	Electrostatic discharge voltage (Machine Model) C=200pF, R=0Ω			
Between drain and source	—	0.5		
	Other combinations	—	0.3	
Tj max.	Max. storage & operating temperature junction temperature	-40	150	°C
Tsoldering	Lead soldering temperature (10 seconds)	—	300	°C

Thermal Characteristics

Symbol	Parameter	Typ.	Max.	Units
Rth1	Thermal resistance junction to ambient IPS1031 TO-220 free air	50	—	°C/W
Rth2	Thermal resistance junction to case IPS1031 TO-220	3.9	—	
Rth1	Thermal resistance junction to ambient IPS1031S D ² Pak std. footprint	60	—	
Rth2	Thermal resistance junction to ambient IPS1031S D ² Pak 1" sqr. footprint	40	—	
Rth3	Thermal resistance junction to case IPS1031S D ² Pak	3.9	—	
Rth1	Thermal resistance junction to ambient IPS1031R D-Pak std. footprint	70	—	
Rth2	Thermal resistance junction to ambient IPS1031R D-Pak 1" sqr. footprint	50	—	
Rth3	Thermal resistance junction to case IPS1031R D-Pak	3.9	—	

Recommended Operating Conditions

These values are given for a quick design. For operation outside these conditions, please consult the application notes.

Symbol	Parameter	Min.	Max.	Units
VIH	High level input voltage	4.5	5.5	
VIL	Low level input voltage	0	0.5	
Ids	Continuous drain current, Tambient=85°C, Tj=125°C, Vin=5V			A
	Rth=5°C/W IPS1031	—	9.5	
	Rth=40°C/W IPS1031S 1" sqr. footprint	—	3.3	
	Rth=50C/W IPS1031R 1" sqr. footprint	—	3	
Rin	Recommended resistor in series with IN pin to generate a diagnostic	0.5	10	kΩ
Max L	Max recommended load inductance (including line inductance) (1)	—	50	μH
Max F	Max. frequency (switching losses = conduction losses)	—	1.5	kHz
Max. t rise	Max. input rising time	—	1	μs

(1) Higher inductance is possible if maximum load current is limited - see figure 11

Static Electrical Characteristics

T_j=25°C, V_{cc}=14V (unless otherwise specified)

Symbol	Parameter	Min.	Typ.	Max.	Units	Test Conditions
R _{ds(on)}	ON state resistance T _j =25°C	—	40	50	mΩ	V _{in} =5V, I _{ds} =8A
	ON state resistance T _j =150°C (2)	—	76	95		
I _{dss1}	Drain to source leakage current	—	0.1	10	μA	V _{cc} =14V, T _j =25°C
I _{dss2}	Drain to source leakage current	—	0.2	20		V _{cc} =28V, T _j =25°C
V _{clamp1}	Drain to source clamp voltage 1	36	39	—	V	I _d =20mA
V _{clamp2}	Drain to source clamp voltage 2	—	40	42		I _d =1A
V _{in clamp}	IN to source pin clamp voltage	5.5	6.5	7.5		I _{in} =1mA
V _{th}	Input threshold voltage	—	1.7	—		I _d =10mA

Switching Electrical Characteristics

V_{cc}=14V, Resistive load=1.5Ω, R_{input}=0Ω, V_{in}=5V, T_j=25°C

Symbol	Parameter	Min.	Typ.	Max.	Units	Test Conditions
T _{don}	Turn-on delay time to 20%	3	10	30	μs	See figure 2
T _r	Rise time 20% to 80%	6	20	40		
T _{doff}	Turn-off delay time to 80%	20	70	200		
T _f	Fall time 80% to 20%	6	15	30		
E _{on} + E _{off}	Turn on and off energy	—	0.7	—	mJ	

Protection Characteristics

Symbol	Parameter	Min.	Typ.	Max.	Units	Test Conditions
T _{sd}	Over temperature threshold	150(2)	165	—	°C	See figure 1
I _{sd}	Over current threshold	12	18	24	A	See figure 1
OV	Over voltage protection (not active when the device is ON)	34	37	—	V	
V _{reset}	IN protection reset threshold	—	1.7	—	V	
T _{reset}	Time to reset protection	15(2)	50	200	μs	V _{in} =0V

Diagnostic

Symbol	Parameter	Min.	Typ.	Max.	Units	Test Conditions
I _{in, on}	ON state IN positive current	15	32	70	μA	V _{in} =5V
I _{in, off}	OFF state IN positive current (after protection latched)	150	230	350		V _{in} =5V

(2) Guaranteed by design

Lead Assignments

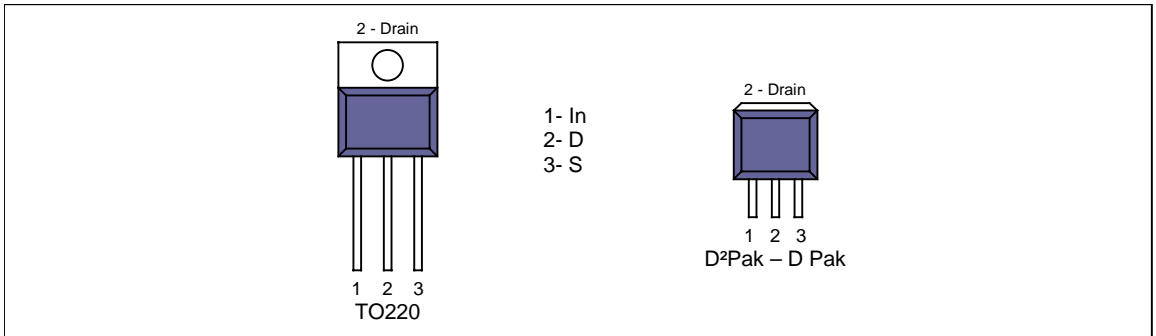

Functional Block Diagram

All values are typical

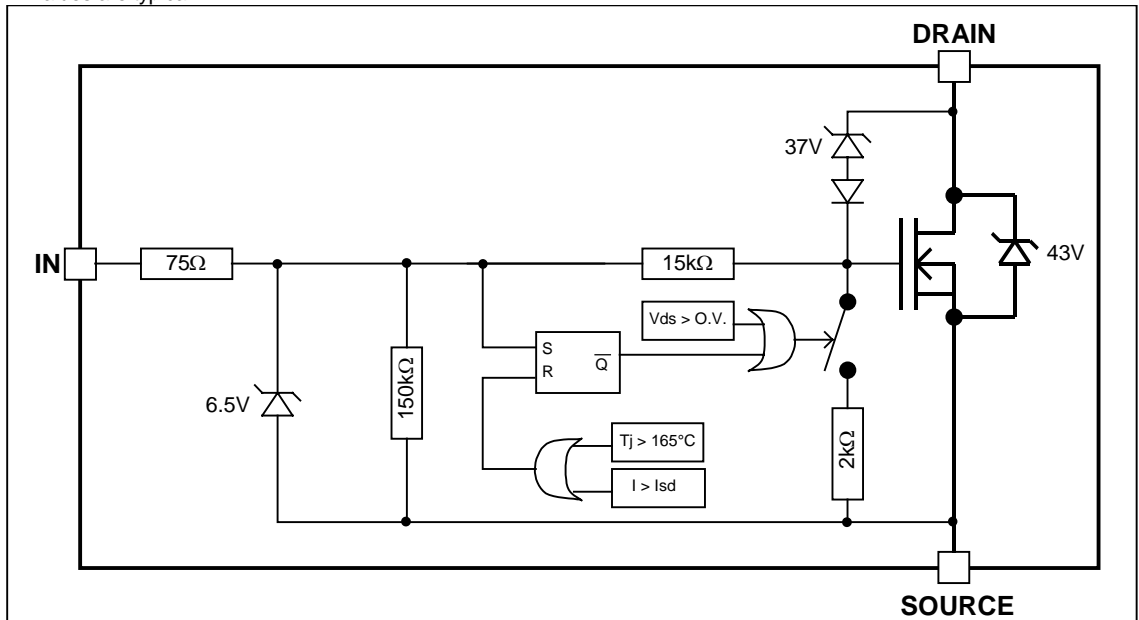

All curves are typical values. Operating in the shaded area is not recommended.

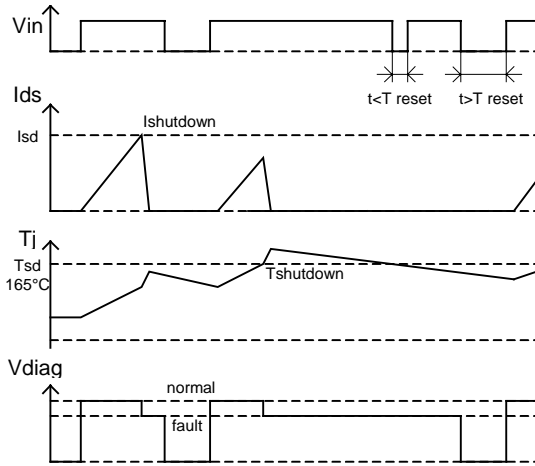

Figure 1 – Timing diagram

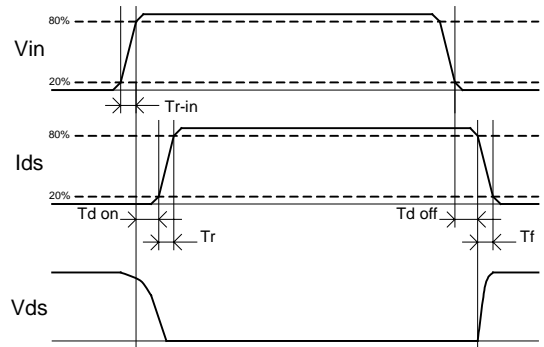

Figure 2 – IN rise time & switching definitions

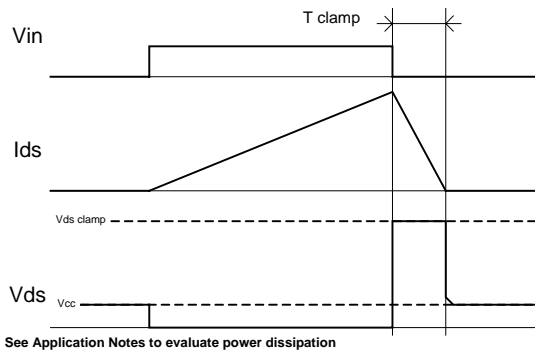

Figure 3 – Active clamp waveforms

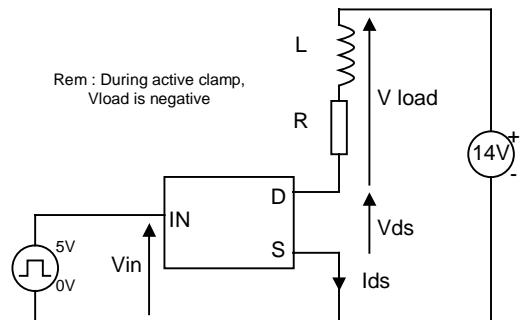

Figure 4 – Active clamp test circuit

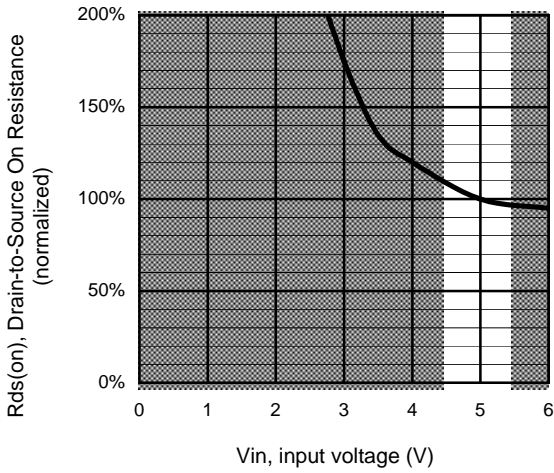

Figure 5 – Normalized Rds(on) (%) Vs Input voltage (V)

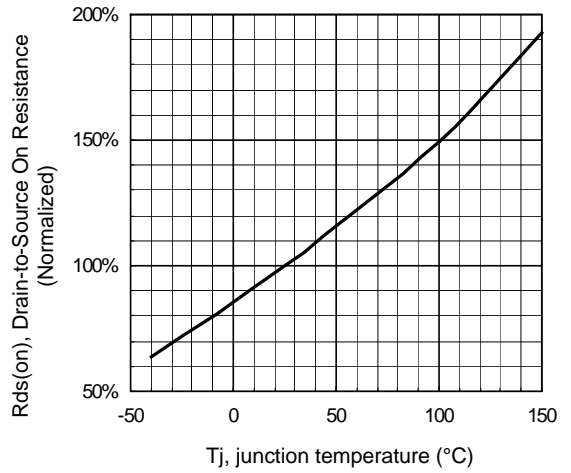

Figure 6 - Normalized Rds(on) (%) Vs Tj (°C)

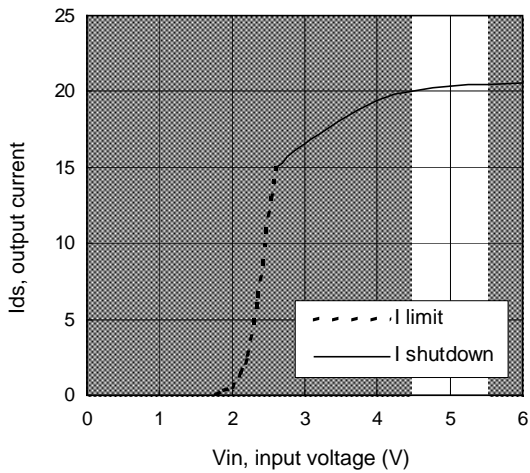

Figure 7 – Current limitation and current shutdown Vs Input voltage (V)

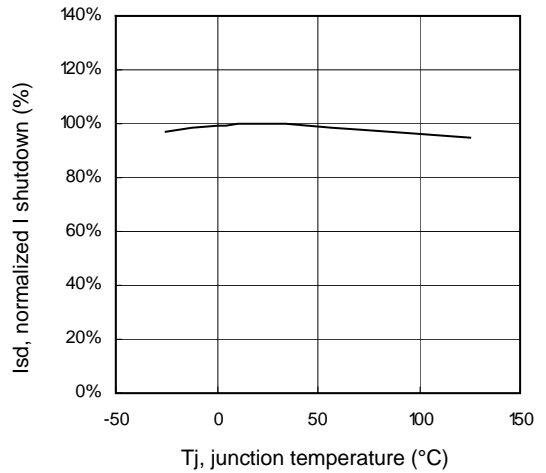

Figure 8 – Normalized I shutdown (%) Vs junction temperature (°C)

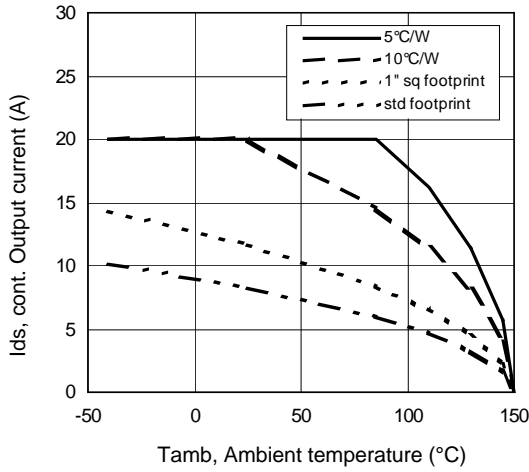

Figure 9 – Max. continuous output current (A) Vs Ambient temperature (°C)

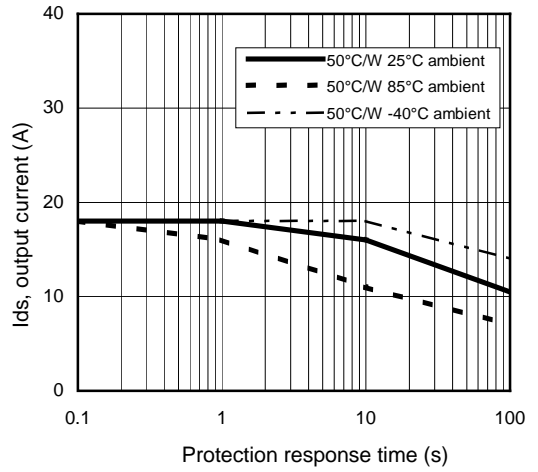

Figure 10 – Ids (A) Vs over temperature protection response time (s)

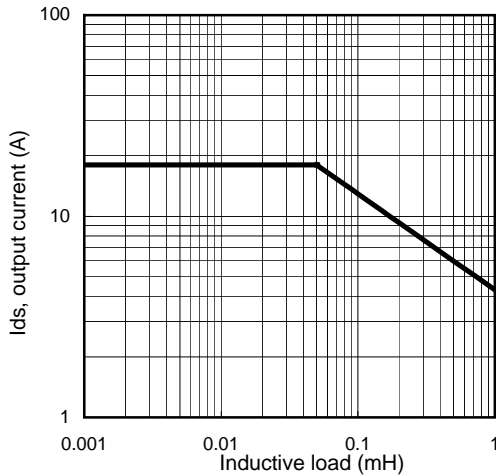

Figure 11 – Max. output current (A) Vs Inductive load (mH)

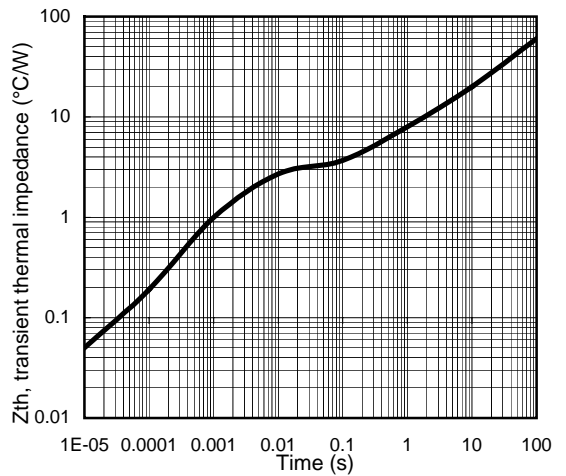

Figure 12 – Transient thermal impedance (°C/W) Vs time (s)

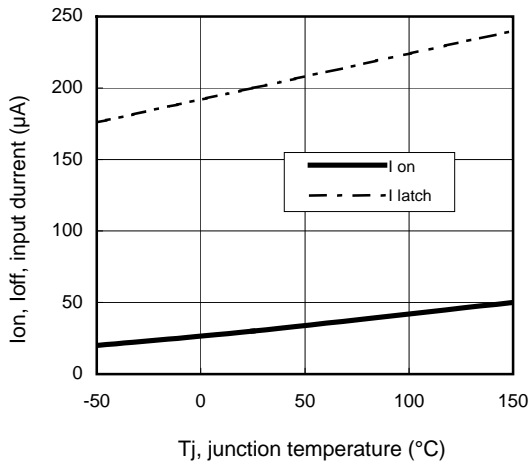

Figure 13 – Input current (µA) On and Off Vs junction temperature (°C)

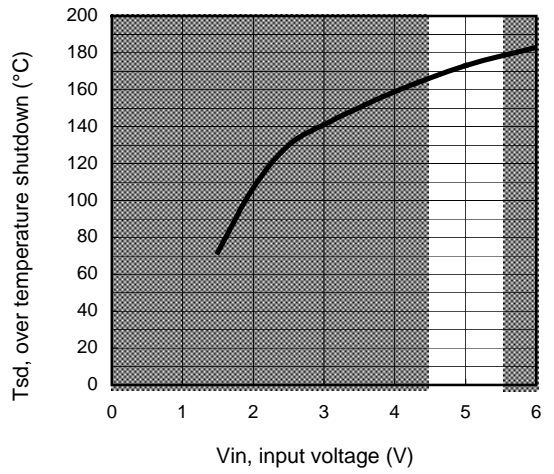
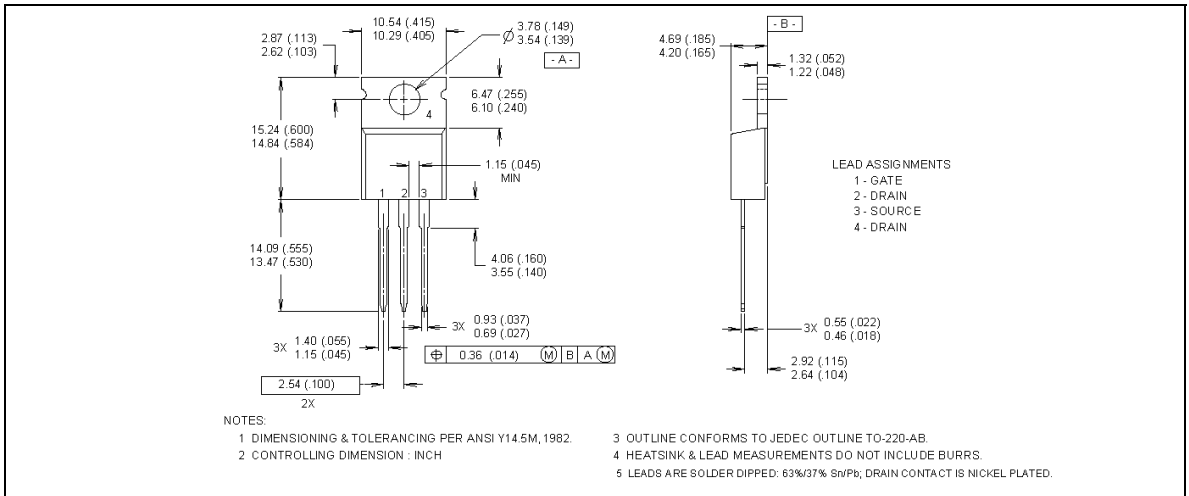
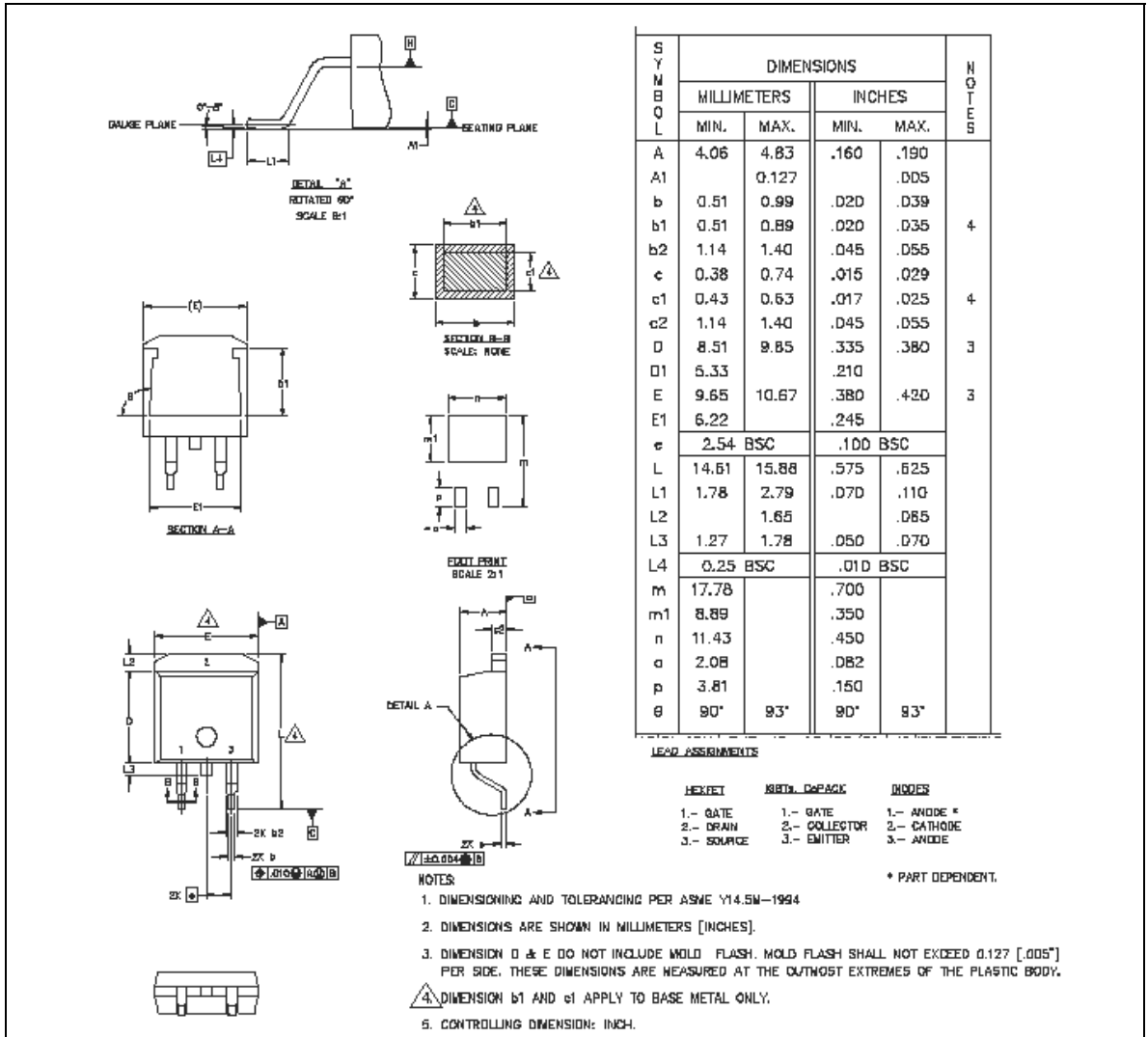

Figure 14 – Over temperature shutdown (°C) Vs input voltage (V)

Case Outline – TO-220 AB



Case Outline - D²Pak (SMD-220)



Case Outline – D-Pak

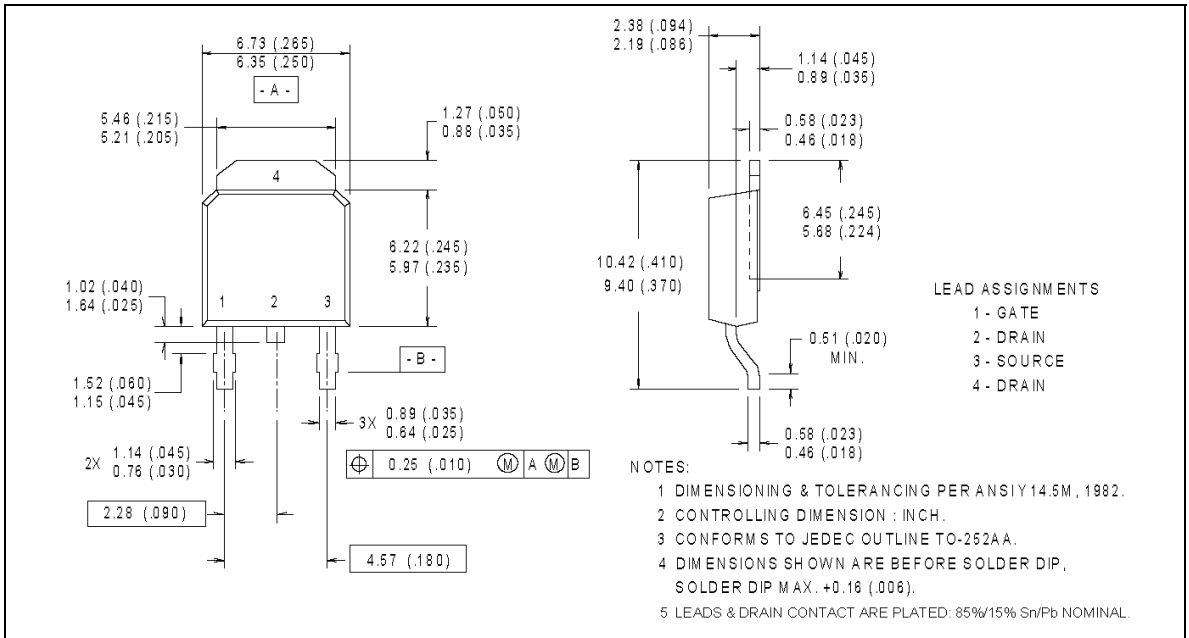

Tape & Reel - D²Pak (SMD220)

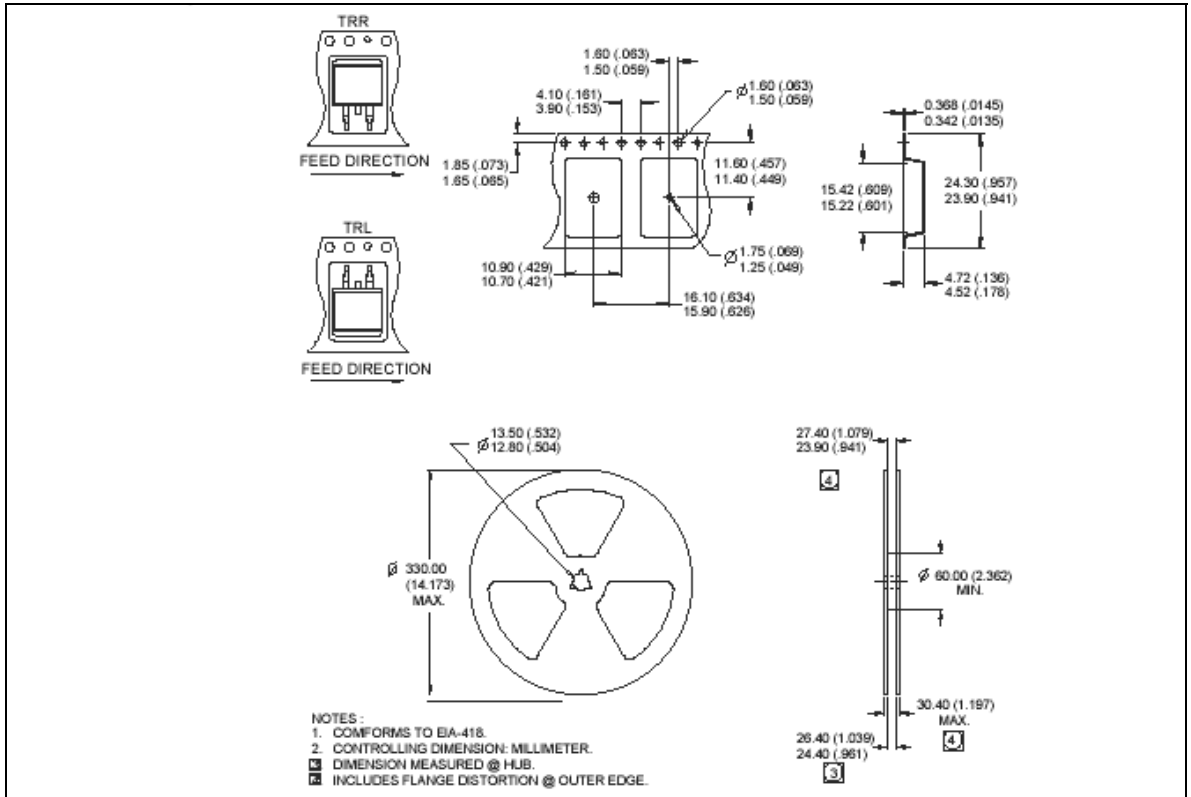

Tape & Reel - D-Pak

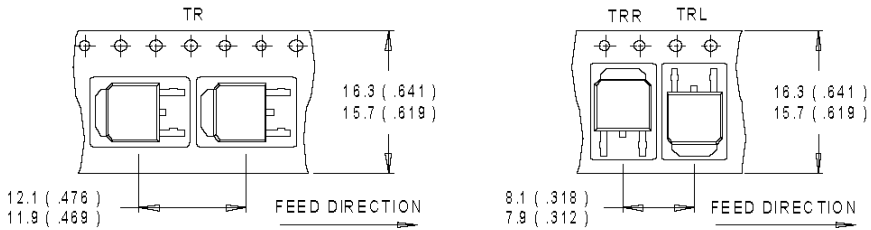

NOTES :

1. CONTROLLING DIMENSION : MILLIMETER.
2. ALL DIMENSIONS ARE SHOWN IN MILLIMETERS (INCHES).
3. OUTLINE CONFORMS TO EIA-481 & EIA-541.

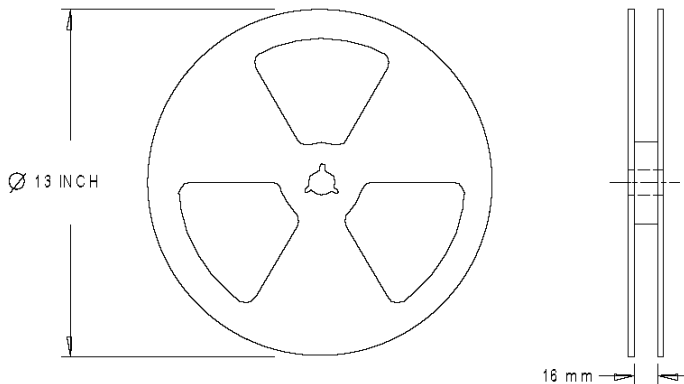

NOTES :

1. OUTLINE CONFORMS TO EIA-481.

Dimensions are shown in millimeters (inches)