



IQS223 DATASHEET

3 Channel capacitive proximity and touch controller with flick or swipe and tap & hold gesture outputs

The **IQS223** ProxSense® IC is a 3-channel self/projected capacitive proximity and touch controller with best in class sensitivity, signal to noise ratio and power consumption. Other features include automatic tuning of the sense electrodes, internal reference capacitor and an internal regulator to reduce total system cost.

RoHS & Reach Compliant

Main Features

- > 1 Global proximity wake-up channel (CH0)
- > 3 Self or projected channel capacitive controller
- > 4 GPIO gesture output pins (80ms pulses; Active high)
- > 2 GPIO strap option input pins for sensitivity selections
- > Configurable 1-dimensional flick or swipe gesture detection with individual direction output pins
- > Tap and hold gesture recognitions and output
- > 72Hz normal power (maximum) sampling rate
- > On chip noise filters and calibration algorithm
- > Automatic adjustment for optimal performance (ATI)
- > Automatic drift compensation
- > User selectable proximity and touch thresholds
- > Long proximity range with combined sensor pin charging
- > Low power options for extensive power saving or wake-up response, suitable for battery applications
- > Supply voltage range: 1.8V to 3.3V
- > Less than 5µA active sensing in low power mode
- > Less than 200µA normal mode operation at 72Hz sampling rate

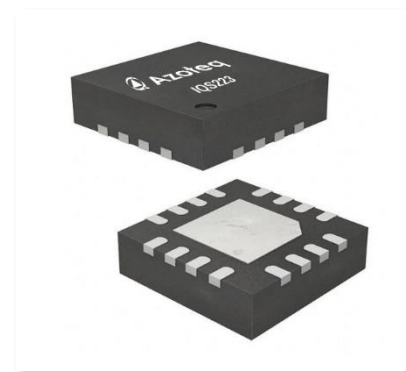

QFN(3x3)-16 package

Representation only

Applications

- > Mechanical key replacement for TWS
- > Volume control for earphones
- > MP3 players
- > Portable electronics
- > Wearable electronics

Available Packages

T _A	QFN(3x3)-16
-20°C to 85°C	IQS223 zzzzzzzz QNR



Contents

1	INTRODUCTION	4
2	ANALOGUE FUNCTIONALITY.....	4
3	DIGITAL FUNCTIONALITY	4
4	HARDWARE CONFIGURATION	5
5	PROXSENSE® MODULE	10
6	POWER MODES	12
7	USER SELECTABLE OTP OPTIONS	15
8	SPECIFICATIONS	24
9	PACKAGING INFORMATION	26
10	DEVICE MARKING	30
11	ORDERING INFORMATION	30

Revision history

Version	Description	Date
1.00	First release	January 2019
1.01	Template Update	July 2019



List of abbreviations

ATI	-	Automatic Tuning Implementation
BOD	-	Brown Out Detection
CH	-	Channel
C_M	-	Mutual capacitance
C_P	-	Parasitic capacitance
CRX	-	Capacitive Receive Electrode
CS	-	Counts
C_S	-	Internal sampling / reference capacitor
EMC	-	Electromagnetic Capability
EMI	-	Electromagnetic interference
ESD	-	Electrostatic Discharge
FTB	-	Fast Transient Burst
GND	-	Ground (common)
GPIO	-	General Purpose Input / Output
GUI	-	Graphic User Interface
IC	-	Integrated Circuit
LP	-	Low Power
LTA	-	Long term Average
MCU	-	Microcontroller Unit
MSL	-	Moisture Sensitive Level
MOQ	-	Minimum Order Quantity
NP	-	Normal Power
N/C	-	Not Connected
OTP	-	One Time Programmable
PCB	-	Printed Circuit Board
PMU	-	Power Management Unit
POR	-	Power-On Reset
POUT	-	Proximity Output
R_S	-	Series resistance
THR	-	Threshold
TX	-	Capacitive Transmit Electrode
UI	-	User Interface
VDDHI	-	Voltage supply positive potential
VREG	-	Internal regulated voltage
VSS	-	Voltage supply negative potential
WDT	-	Watch Dog Timer



1 Introduction

The **IQS223** is a 3-channel capacitive proximity and touch sensor featuring an internal voltage regulator and reference capacitor (C_S). The sensors can be configured as self or projected capacitance.

The device has 4 pins for the connection of the sense electrodes, which consist of 3 self electrodes, or 3 receivers and 1 transmitter. The transmitter output pin is also shared with a proximity output detection status.

The device automatically tracks slow varying environmental changes via various filters, suppresses noise and is equipped with an Automatic Tuning Implementation (ATI) to adjust the device for optimal sensitivity and compensate for changes in the operating environment.

1.1 Applicability

All specifications, except where specifically mentioned otherwise, provided by this datasheet are applicable to the following operational ranges:

- > Temperature -20°C to $+85^{\circ}\text{C}$
- > Supply voltage (V_{DDHI}) 1.8V to 3.3V

1.2 Device operation

The **IQS223** utilises **One Time Programmable (OTP)**, non-volatile, memory banks commonly referred to as floating gates or programmable fuses. This provide various device setup options.

With a normal prox activation, which occurs when a hand is brought close to any of the sensor electrodes, the proximity output pin will become active HIGH. When a valid gesture (flick, swipe, tap or hold) event is qualified, according to the selectable options for coordinate travel and gesture activation time, the applicable output pin will output an active HIGH pulse for 80ms period or until the hold gesture clears. The proximity output will clear as soon as the prox condition is reversed (the hand removed from the sensor) and a proximity event is inactive according to the sensor data.

2 Analogue functionality

The two distinct capacitive sensor modes offered by the **IQS223** are self capacitive and projected capacitive modes.

For self capacitive the CRX electrodes are arranged in an interleaving slider electrode pattern and is successively charged and discharged in electrical (capacitive) reference to the common system ground.

During projected capacitive mode operation CRX and TX electrodes are arranged in a suitable configuration that results in a projected capacitance (C_m) forming between the two closely spaced electrodes. TX is charged to a set positive potential during a charge cycle which results in negative charge buildup at CRX.

The resulting charge displacement in both modes (self and projected) is then measured within the **IQS223** device through a charge transfer process that is periodically initiated by the digital circuitry. The capacitance measurement circuitry makes use of an internal reference capacitor C_S and voltage reference (V_{REG}).

The measuring process is referred to as a conversion and consists of the discharging of C_S and C_X capacitors, the charging of C_X and then a series of charge transfers from C_X to C_S until a trip voltage is reached. The number of charge transfers required to reach the trip voltage is referred to as the Counts (CS) value.

In conjunction the following features are also provided:

- > Power On Reset (POR) detection.
- > Brown Out Detection (BOD).
- > Internal voltage regulation for accurate sampling.

3 Digital functionality

The digital processing provides the following features:

- > Management of BOD and WDT events.
- > Conversion cycles at the selected sampling rate.
- > Processing of the CS and execution of algorithms and digital filtering.
- > Monitoring and execution of the ATI algorithm.
- > Prox, touch and gesture event detection.
- > Management of the device outputs.



4 Hardware configuration

The **IQS223** can be configured to charge in self- or projected-capacitive modes depending on the OTP configuration. The IQS223 is default in self capacitive mode and can be set to projected-capacitive mode by setting the “sensing mode” bit in OTP bank 4: bit 3. Three channels are used in both modes and the global proximity channel consist of charging all electrodes simultaneously.

In **self capacitive** mode, the **IQS223** uses only the 3 CRX pins to realise 3 channels. The 3 channels can be used for global tap / hold gestures on any of the electrodes or as a one-dimensional slider for flick / swipe gestures.

In **projected-capacitive** mode, the **IQS223** charges 3 channels using a dedicated CRX and TX combinational layout. The proximity output will be time shared with the transmit signal on the TX/POUT pin in projected capacitive mode.

4.1 IQS223 pin allocation

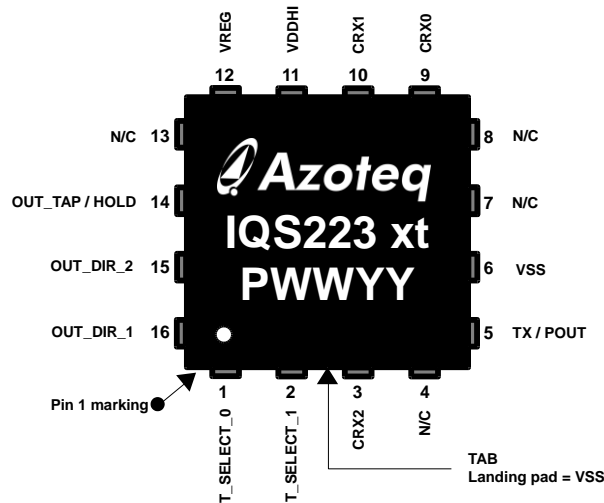

Table 4.1 *IQS223 QFN(3x3)-16 device & pin-out illustration (marking may differ)*



Table 4.2 IQS223 QFN(3x3)-16 pin-out descriptions

Pin	Pin name	Function
1	T_SELECT_0	External ATI Target Adjustment
2	T_SELECT_1	External ATI Target Adjustment
3	CRX2	Sensor receive pin
4	N/C	Not Connected
5	TX / POUT	Sensor transmit pin / Digital output
6	VSS	Common ground (GND) reference supply
7	N/C	Not Connected
8	N/C	Not Connected
9	CRX0	Sensor receive pin
10	CRX1	Sensor receive pin
11	VDDHI	Supply Voltage Input (>=1uF bypass cap required)
12	VREG	Internal Regulator (>=1uF bypass cap required)
13	N/C	Not Connected
14	OUT_TAP / HOLD	Digital Output
15	OUT_DIR_2	Digital Output
16	OUT_DIR_1	Digital Output



4.2 Reference design

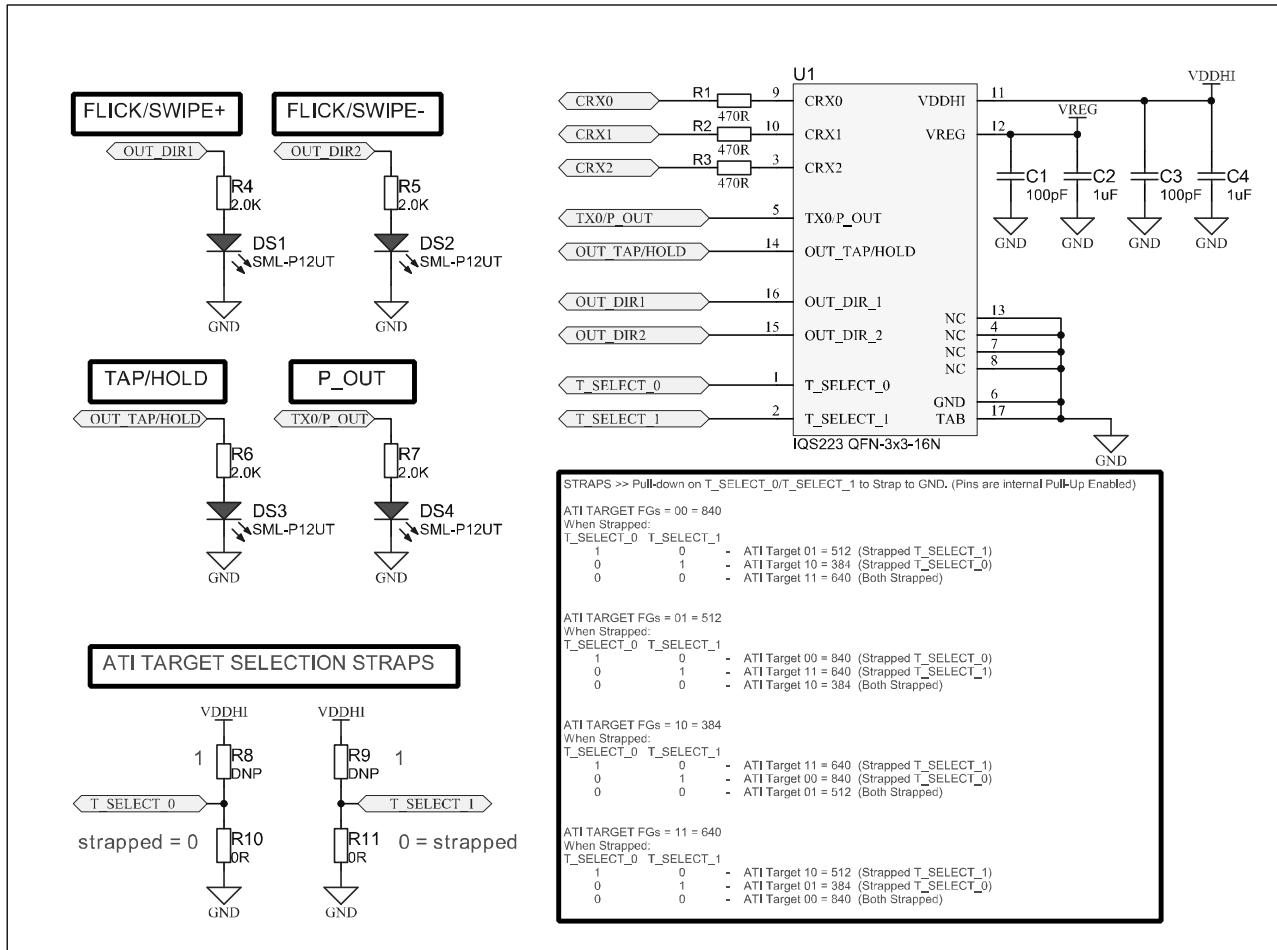

Figure 4.1 IQS223 reference design.

Figure 4.1 shows the following:

- > Schematic for default power mode, see guide for capacitor selection in extreme low power modes below:

Low power scan time	80ms (default)	≥112ms	≥160ms
Capacitor recommendation	C1 = 1µF C4 = 1µF	C1 = 1µF C4 = 2.2µF	C1 = 2.2µF C4 = 4.7µF

- > CRX0, CRX1 & CRX2 are electrode elements but can be loaded with discrete capacitors to GND for slight variations in sensitivity. The recommended value is 1pF to 60pF, depending on the capacitance of the size and references of the electrode layouts.
- > R1, R2, R3 = 470Ω (0603 package size) for added ESD protection.
- > R10 & R11: possible 0 Ω strap connections can be placed to strap the T_SELECT pins (internal pull-up during start-up and read operation) to GND for alternative target selections:
 - Please refer to the explanatory note in the figure of all possible options
 - Please note that the straps must be in place before IQS223 powering (POR) to be read. Changes during device operation not possible.



4.3 Proposed sensor pattern layouts

4.3.1 Self capacitive electrodes

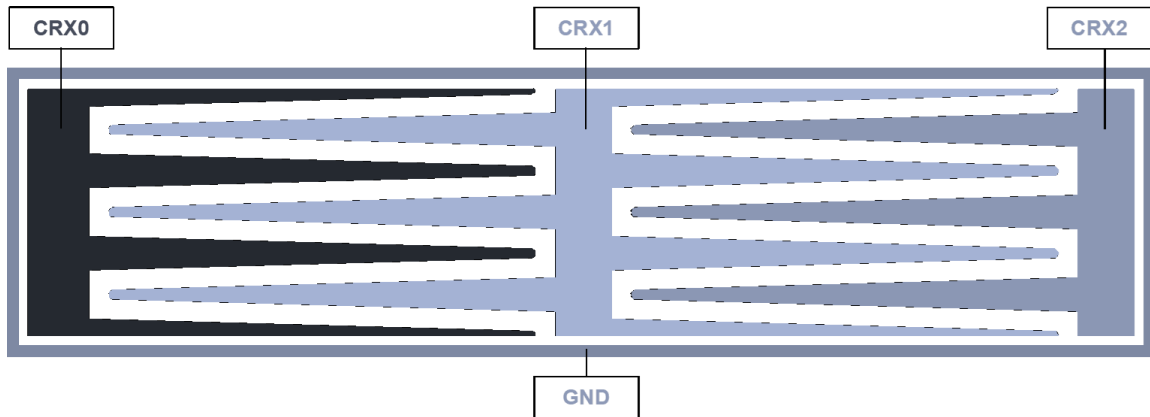

Figure 4.2 Example of a 3-channel self capacitive slider. Suggested gaps between electrodes $\geq 0.8\text{mm}$.

4.3.2 Projected capacitive electrodes

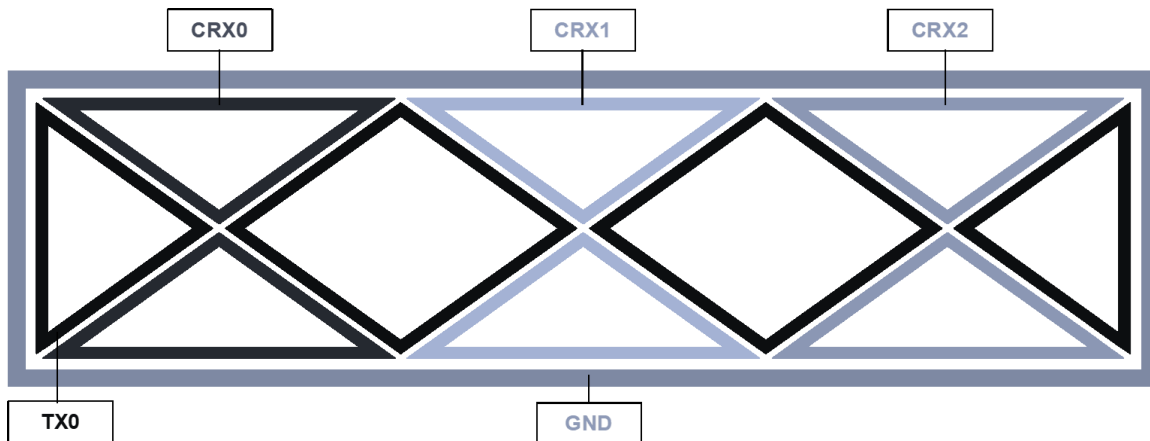

Figure 4.3 Example of a 3-channel projected capacitive slider. Diamonds may be empty (as illustrated), hatched or solid conductor fills.

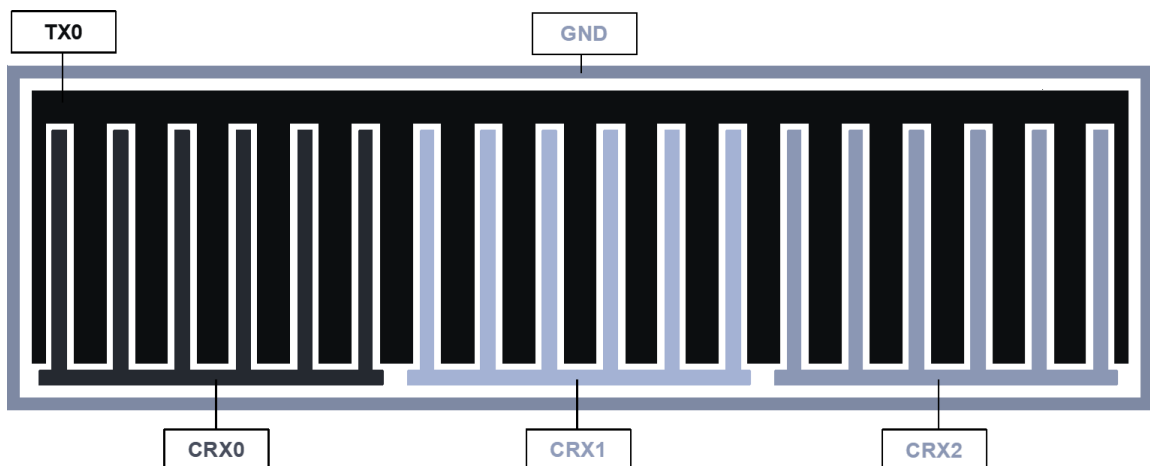

Figure 4.4 Alternative layout of a 3-channel projected capacitive slider. Ideal for slider widths exceeding 15mm.



4.4 Power Supply and PCB Layout

Azoteq IC devices provide a high level of on-chip hardware and software noise filtering and ESD protection (refer to application note “**AZD013 – ESD Overview**” available on the [Azoteq website](#)). Designing PCB's with better noise immunity against EMI, FTB and ESD in mind, it is always advisable to keep the critical noise suppression components like the de-coupling capacitors and series resistors in **Figure 4.1** as close as possible to the IC. Always maintain a good ground connection and ground pour underneath the IC. For more guidelines please refer to the relevant application notes as mentioned in **Section 4.5**.

4.5 Design rules for harsh EMC environments

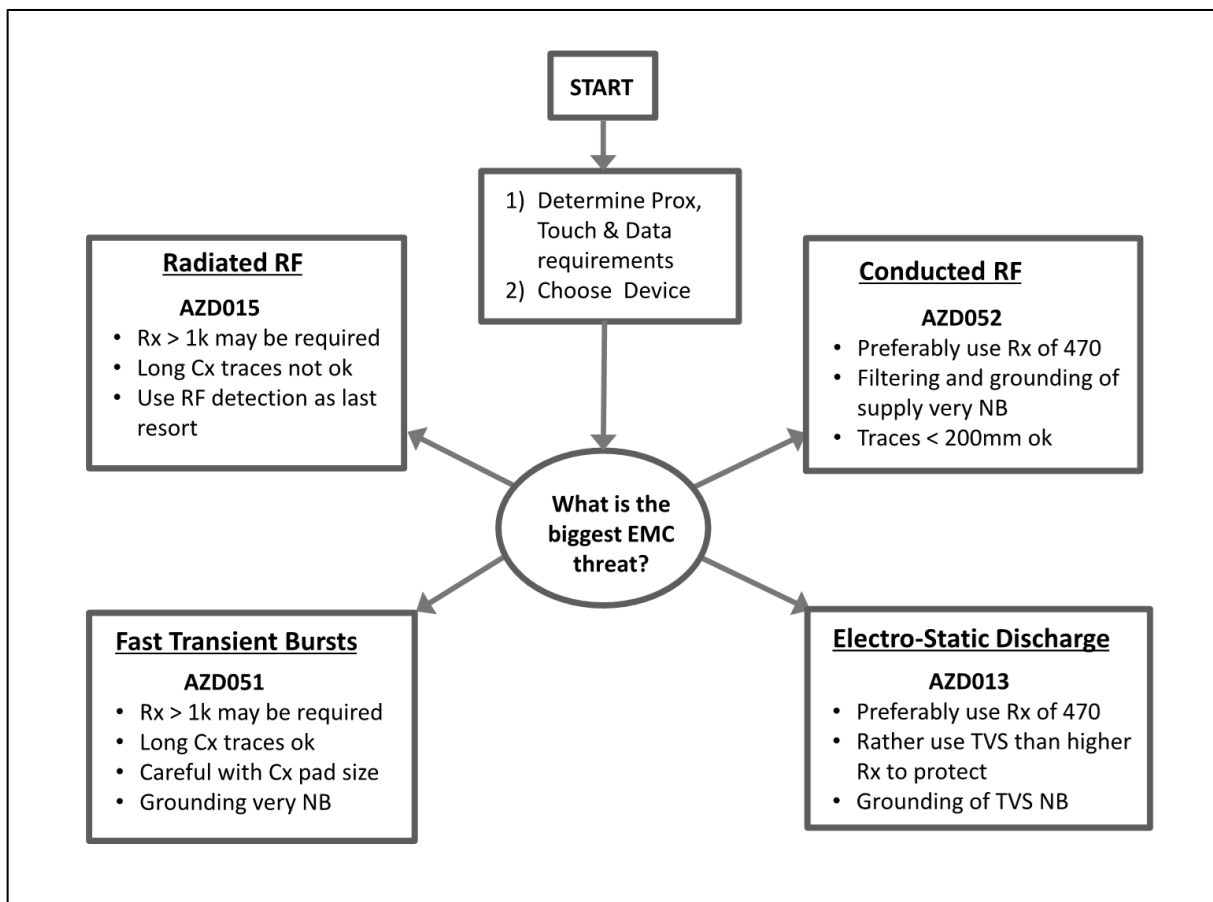

Figure 4.5 EMC troubleshooting flow diagram

> Applicable application notes: AZD013, AZD015, AZD051, and AZD052.

4.6 High sensitivity

Through patented design and advanced signal processing, the device is able to provide extremely high sensitivity to detect proximity. This enables designs to detect proximity at distances that cannot be equaled by most other products. When the device is used in environments where high levels of noise or floating metal objects exist, a reduced proximity threshold is proposed to ensure reliable functioning of the sensor. The high sensitivity also allows the device to sense through overlay materials with low dielectric constants, such as wood or porous plastics.

For more guidelines on the layout of capacitive sense electrodes, please refer to application note **AZD008**, available on the Azoteq web page: www.azoteq.com.



5 ProxSense® module

The **IQS223** contains a ProxSense® module that uses patented technology to provide detection of proximity and touch conditions on numerous sensing lines.

The ProxSense® module is a combination of hardware and software, based on the principles of charge transfer measurements.

5.1 Charge transfer concept

On ProxSense® devices like the **IQS223**, capacitance measurements are taken with a charge transfer process that is periodically initiated.

For projected capacitive sensing, the device measures the capacitance between 2 electrodes referred to as the transmitter (TX) and receiver (CRX).

The measuring process is referred to as a charge transfer cycle and consists of the following:

- > Discharging of an internal sampling capacitor (C_s) and the resultant electrode capacitors for a specific channel (self: CRX; projected: TX + CRX combination).
- > charging of TX electrode connected and forming part of the channel
- > and then a series of charge transfers from the CRX electrodes to the internal sampling capacitors (C_s), until the trip voltage is reached.

The number of charge transfers required to reach the trip voltage on a channel is referred to as the Current Samples (CS) or Count value (Counts).

The device continuously repeats charge transfers on the sense electrodes connected to the CRX pins. For each channel a Long Term Average (LTA) is calculated and stored. The count (CS) values are processed and compared to the LTA value to detect Touch and Proximity events.

Please note: Attaching scope probes to the TX/CRX pins will influence the capacitance of the sense electrodes and therefore the related CS values of those channels. This will have an instant effect on the CS measurements.

5.2 Long term average

The Long Term Average (LTA) filter is the baseline or reference value. The LTA is calculated to continuously adapt to any environmental drift. The LTA filter is calculated from the CS value for each channel. The LTA filter allows the device to adapt to environmental (slow moving) changes/drift. Actuation (prox or touch) decisions are made by comparing the CS value with the LTA reference value.

5.3 Determine Touch or Prox

An event is determined by comparing the CS value with the LTA. Since the CS reacts differently when comparing the self- with the projected capacitance technology, the user should consider only the conditions for the technology being used.

An event is recorded if:

- > Self: $CS < LTA - \text{threshold}$
- > Projected: $CS > LTA + \text{threshold}$

The threshold can be either a proximity or touch threshold, depending on the channel being processed.

Note that a proximity condition will be forced if there is a touch condition on any of the touch channels.

Please refer to **Section 7.2.2** and **7.2.1** for proximity and touch threshold selections.

5.4 ATI

The Automatic Tuning Implementation (ATI) is a sophisticated technology implemented on the ProxSense® series devices. It allows for optimal performance of the devices for a wide range of sense electrode capacitances, without modification or addition of external components.

The ATI allows the tuning of two parameters, an ATI multiplier and an ATI compensation, to adjust the count values for an attached sense electrode.

ATI allows the designer to optimize a specific design by adjusting the sensitivity and stability of each channel through the adjustment of the ATI parameters.

The **IQS223** will always execute an ATI function at POR and possibly during runtime if



the LTA values drifts outside the re-ATI limits (see re-ATI section below).

For more information regarding the ATI algorithm, please contact Azoteq at: proxsensesupport@azoteq.com

5.4.1 ATI Sensitivity

On the **IQS223** device, the user can select the base values (**Section 7.2.3**) and the target values (**Section 7.2.1**) for the proximity channel (CH0) and touch channels (CH1, CH2, and CH3) separately.

A rough estimation of sensitivity can be calculated as:

$$Sensitivity \propto \frac{Target}{Base}$$

As can be seen from this equation, the sensitivity can be increased by either increasing the target value or decreasing the base value. It should, however, be noted that a higher sensitivity will yield a higher noise susceptibility.

5.4.2 ATI Target

The target value is reached by adjusting the internal compensation bits for each channel (ATI target limited to 2048 counts).

5.4.3 ATI Base (Multiplier)

The charge transfer frequency will influence the base value selection of channels.

ATI automatically adjusts the on-chip multiplier selections accordingly to reach the selected (desired) base value. Please refer to **Section 7.2.3** for available base value options.

5.4.4 Re-ATI

An automatic re-ATI event will occur if the LTA's are outside its re-ATI limits. The re-ATI limit or ATI boundary is calculated as an eighth (1/8*LTA) above and below the LTA. For example:

- > Target = 840 counts, LTA = ±840counts
- > ATI boundaries = 840 ± 105 counts
- > Re-ATI will occur if the LTA exceeds 945 counts.
- > And for the alternative case, for CS < LTA, and after a halt condition time-out, re-ATI will then also occur if the LTA is below 735 counts.

Note: Re-ATI will automatically clear all active proximity, touch and halt states.

5.4.5 ATI ERROR

The ATI can run into an error during execution, typically if the ATI targets cannot be reached. This will automatically cause the algorithm to start execution from the beginning.



6 Power Modes

6.1 Normal power sampling

The normal power sampling mode is the maximum, full sampling (CH0, 1, 2 & 3) active power mode with a fixed sampling period of 14ms. The **IQS223** will ensure that the sampling rate stays fixed even when doing conversions at slower charge transfer frequencies or higher channel targets.

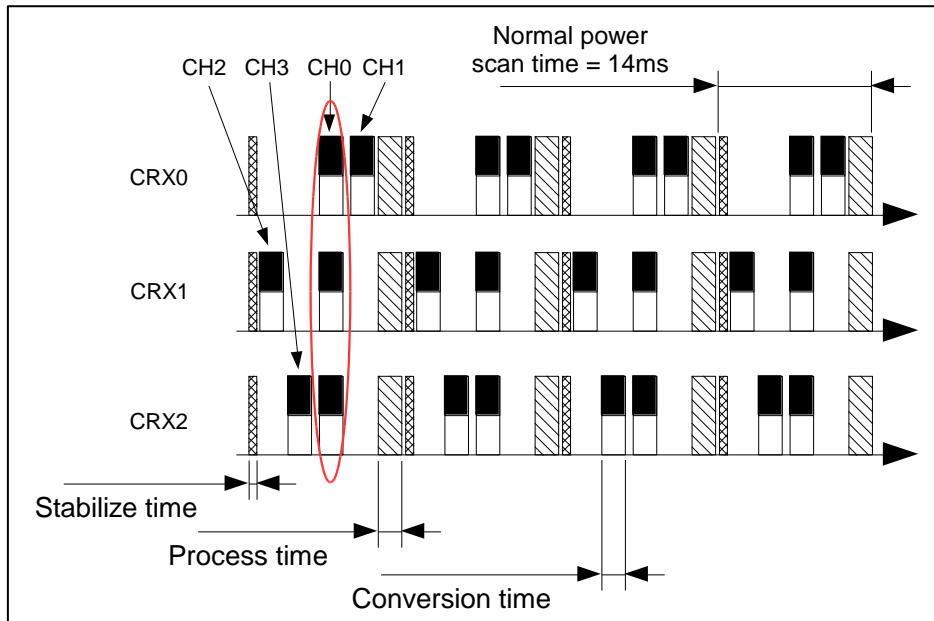

Figure 6.1 IQS223 Normal power mode conversion sequence and timing

Table 6.1 Typical normal power conversion time periods

Nominal timings of IQS223 in normal power with default settings	
$t_{\text{stabilize}}$	0.3ms
$t_{\text{conversion}}$	1.1ms
t_{process}	1.9ms
NP_{scan}	14ms
t_{sleep}	Adjusted to meet 14ms NP_{scan} (sleep padding) Minimum 0ms (no sleep)



6.2 Low power sampling

The **IQS223** IC has configurable low power modes, specifically designed to reduce current consumption during idle/sleep states of battery applications. When designing for low power operation, the reference voltage (V_{REG}) capacitors should ensure that the V_{REG} voltage does not drop more than 50mV during low power operations. This can lead to inaccurate sensing or device resets.

The power modes are implemented around the occurrence of a charge cycle every t_{LP} seconds. The value of t_{LP} is determined by the fixed LP_{scan} value selection in **Section 7.2.1**. The LP_{scan} period is set according to the “Power mode” bit options in OTP bank 2: bit6:4. Only CH0 is charged during LP and is thus effectively always active (NP & LP). Other active channels will be charged periodically during Low power mode to keep their LTA filter values up to date. This is implemented by executing a single normal power conversion every 128 LP conversions.

Lower sampling times yield significantly lower power consumption, but also decreases the response time of the event in order to wake the device from LP. With the detection of an undebounced proximity event the **IQS223** will zoom to NP mode, thereby allowing a fast reaction time for further possible touch and gesture events.

The LP charge cycle timing is illustrated in Figure 6.2 and Table 6.2.

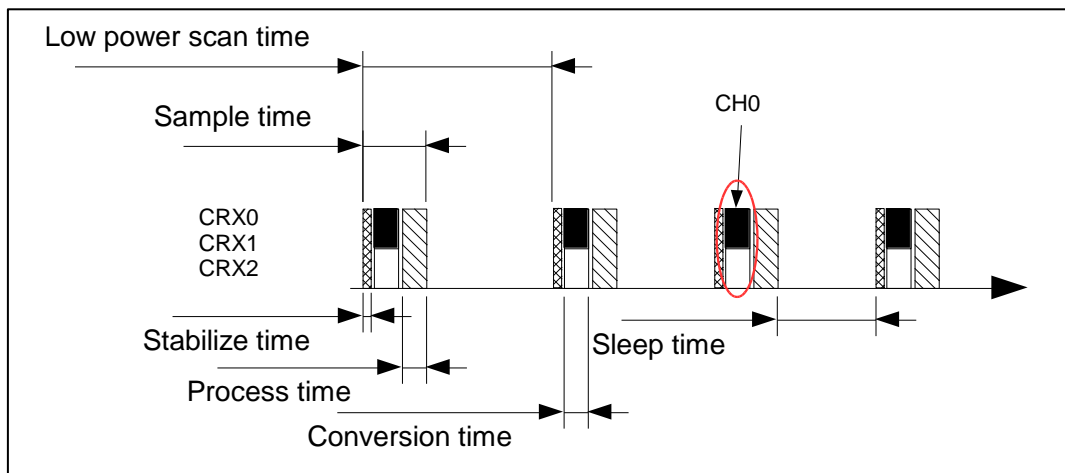

Figure 6.2 IQS223 Low power mode conversion sequence and timing

Table 6.2 Typical low power conversion time periods

Nominal timings of IQS223 in Low Power with default settings	
$t_{stabilize}$	0.3ms
$t_{conversion}$	1.1ms
$t_{process}$	1.9ms
LP_{scan}	OTP Bank4 bit6:4 selection (ms)
t_{sleep}	Adjusted after sample is completed to meet correct LP_{scan} period



6.3 Prox detection and power mode transitions

The IQS223 will wake from a Low power mode upon a valid prox detection and immediately zoom to Normal power sensing mode. The device will remain in Normal power mode during active use with new touch and prox conditions resetting the halt timer. If no new prox condition is detected the device will re-enter the assigned Low power mode upon halt timeout. Halt times differ depending whether a prox or touch condition remains active or clears (refer to the LTA halt time section).

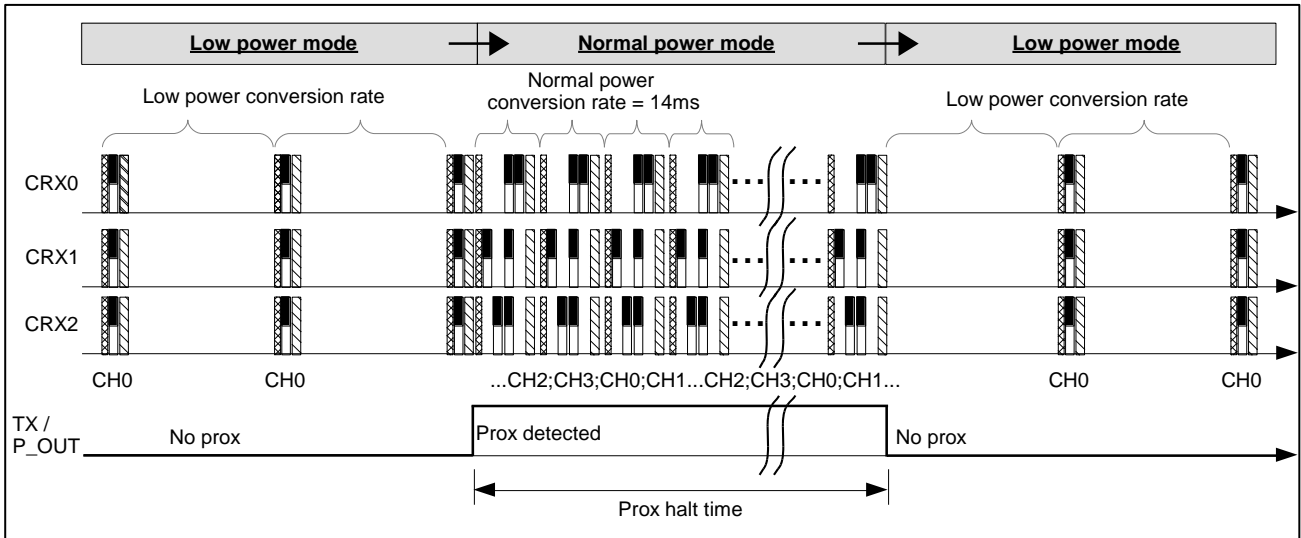

Figure 6.3 IQS223 Prox wake-up from LP mode, NP mode and back into LP mode



7 User selectable OTP options

OTP bank 0								IQS223 000000xx QNR (ordering code)								[x = hex]	
Bit7	6	5	4	3	2	1	Bit 0	Bit7	6	5	4	3	2	1	Bit 0		
CH3 Touch threshold				CH2 Touch threshold				CH1 Touch threshold				Proximity threshold					
00 = 8/256 *LTA 01 = 12/256 *LTA 10 = 16/256 *LTA 11 = 20/256 *LTA				00 = 8/256 *LTA 01 = 12/256 *LTA 10 = 16/256 *LTA 11 = 20/256 *LTA				00 = 8/256 *LTA 01 = 12/256 *LTA 10 = 16/256 *LTA 11 = 20/256 *LTA				00 = 8 counts 01 = 4 counts 10 = 10 counts 11 = 12 counts					
OTP Bank 1								IQS223 0000xx00 QNR								[x = hex]	
Bit7	6	5	4	3	2	1	Bit 0	Bit7	6	5	4	3	2	1	Bit 0		
ATI Base CH1				ATI Base CH1				ATI Base CH2				ATI Base CH0					
00 = 90 counts 01 = 74 counts 10 = 122 counts 11 = 106 counts				00 = 90 counts 01 = 74 counts 10 = 122 counts 11 = 106 counts				00 = 90 counts 01 = 74 counts 10 = 122 counts 11 = 106 counts				00 = 90 counts 01 = 74 counts 10 = 122 counts 11 = 106 counts					
OTP Bank 2								IQS223 00xx0000 QNR								[x = hex]	
Bit7	6	5	4	3	2	1	Bit 0	Bit7	6	5	4	3	2	1	Bit 0		
Gesture type	Power mode				LTA halt time	CH0 Target		CH1, 2, 3 Target									
0 = Flick 1 = Swipe	000 = 80ms 001 = Always normal power (14ms) 010 = 16ms 011 = 32ms 100 = 48ms 101 = 64ms 110 = 112ms 111 = 160ms				0 = 20s 1 = Prox: 6s, Touch: 2s, All 3 CH's touched: 20s	0 = 1.0 x CH1,2,3 Target 1 = 1.5 x CH1,2,3 Target		00 = 840 counts* 01 = 512 counts* 10 = 384 counts* 11 = 640 counts* *Note: OTP 2 Bit1:0 XOR T_SELECT_1:T_SELECT_0 => Target selection									
OTP Bank 3								IQS223 0x000000 QNR								[x = hex]	
Bit7	6	5	4	3	2	1	Bit 0	Bit7	6	5	4	3	2	1	Bit 0		
Reserved				Flick/Swipe time				Tap time									
				00 = 800ms 01 = 400ms 10 = 600ms 11 = 1000ms				00 = 500ms 01 = 250ms 10 = 750ms 11 = 1000ms									
OTP Bank 4								IQS223 x0000000 QNR								[x = hex]	
Bit7	6	5	4	3	2	1	Bit 0	Bit7	6	5	4	3	2	1	Bit 0		
Reserved				Sensing mode	Charge transfer frequency		Flick/Swipe threshold										
				0 = Self 1 = Projected	0 = Self: 500kHz = Proj: 2MHz 1 = Self: 250kHz = Proj: 1MHz		00 = 40% of full length 01 = 20% of full length 10 = 60% of full length 11 = 80% of full length										

Table 7.1 Configurable OTP bank's bit descriptions



7.2 OTP Setup options

The following sections describes the individual OTP options. The heading format is as follow:

OTP bit location	Name of the OTP option (applicability)	[units of measurement]
------------------	----------------------------------------	------------------------

7.2.1 Touch thresholds

Bank0: bit 7:2	Touch thresholds (CH3 : CH2 : CH1)	[fraction of LTA]
----------------	------------------------------------	-------------------

A touch threshold for each channel can be selected by the designer to obtain the desired touch sensitivity. There are 4 options available for each individual channel. The touch threshold is calculated as a fraction of the Long Term Average (LTA) given by,

$$T_{THR} = x/256 \times LTA \text{ [counts]}$$

With lower target values (therefore lower LTA) the touch threshold (T_{THR}) calculated will be lower and vice versa. Individual touch thresholds can be set for each channel, by writing the “CH1 Touch Threshold” for channel 1, “CH2 Touch Threshold” for channel 2 and “CH3 Touch Threshold” for channel 3 bits in OTP bank 0: bit 7:2.

7.2.2 Proximity threshold

Bank0: bit 2:0	Proximity threshold (CH0)	[counts]
----------------	---------------------------	----------

Channel 0 is the global proximity channel consisting of charging all the electrodes at once. A proximity threshold for channel 0 can be selected for the application, to obtain the desired proximity trigger level for Normal power mode execution. The proximity threshold is selectable as one of four possible options. The threshold values (in counts) are specified by the “Proximity Threshold” bits in OTP bank 0: bits 1:0.

7.2.3 Base values

Bank1: bit 7:0	ATI Base values (CH3 : CH2 : CH1 : CH0)	[counts]
----------------	-----------------------------------------	----------

The **IQS223** has the option to change the base value of the proximity channel (CH0) as well as each touch channel (CH1, CH2 and CH3) separately. This base value serves as an input parameter for the ATI algorithm. This provides the user with an option to select the sensitivity of the **IQS223** sensor channels without changes to the hardware (CRX/TX sizing / routing or using external loading capacitors).

The base values are selected by writing to the “ATI Base” option bits for CH0, CH1, CH2 and CH3 in OTP bank 1: bit 7:0. There are four different options to choose from.

The base value influences the overall sensitivity of the channel and establishes a base count from where the ATI algorithm starts executing. A lower base value will typically result in a higher sensitivity of the respective channel, as lower multipliers will be selected by the ATI algorithm and effectively requiring more compensation for the specific channel.

7.2.1 Gesture type

Bank2: bit 7	Gesture type (Flick / Swipe)	[ms]
--------------	------------------------------	------



The **IQS223** provide two distinct linear slider gestures which require linear movement, namely the flick and swipe gestures. Please refer to section 7.4 Gestures explaining the difference between flick and swipe gestures. Depending on the specific gesture type selected in OTP bank 2: bit 7, the output will be initiated accordingly for either one of the two possible sliding gesture types.

7.2.1 Power modes

Bank2: bit 6:4	Power mode (Low power sampling rate selection)	[ms]
----------------	------------------------------------------------	------

The **IQS223** have a fixed normal power mode sample rate (during active proximity detection and 2.5 seconds after the last active proximity sample) as well as a selectable low power report rate.

The normal power mode sampling rate is fixed at 71Hz, i.e. a sampling period of 14ms, during which all channels are sensed. If there is no longer a proximity event active after 2.5s, the device will enter the low power mode.

During low power modes only CH0 (the distributed proximity channel) is active. The low power mode sampling rate can be selected using the available OTP configuration options in OTP Bank 2: bit 6:4.

For the “always normal mode” option the device will never enter low power mode and will continue to sample all four channels at the normal power mode.

7.2.2 LTA halt time

Bank2: bit 3	LTA Halt time (Halt time selection for persistent activations)	[sec]
--------------	----------------------------------------------------------------	-------

The LTA filters for all channels will halt simultaneously when a proximity event is active on CH0 (the global prox channel). The halt condition will remain for a given time period and is referred to as the *halt time*. The halt time can be selected as one of the following options:

- > Default configuration (OTP bank 2: bit 3 = '0'):
 - Prox: 6 seconds halt time
 - Any touch or combination of touches: 20 seconds halt time
- > Alternative configuration (OTP bank 2: bit 3 = '1'):
 - Prox: 6 seconds halt time
 - 2 or less channels in touch: 2 seconds halt time
 - All 3 channels in touch: 20 seconds halt time

7.2.3 Target Values

Bank2: bit 2:0	ATI Target values (CH0 : CH1 : CH2 : CH3)	[counts]
----------------	-------------------------------------------	----------

The **IQS223** has a global option for CH1, CH2 and CH3 target value. The target value is determined by the condition of the external strap options (T_SELECT_1 & T_SELECT_0) and the state of OTP Bank2: bit 1:0. Please refer to Figure 4.1 and the applicable OTP option given in Table 7.1.

Target selection = (T_SELECT_1:T_SELECT_0) XOR (OTP_Bank2 bit1:0)

The CH0 target value can either be equal to the target value selected for CH1, CH2 and CH3 or it can be multiplied by 1.5 times the target value for the touch channels.

The default target value of the **IQS223** is 840 counts for the touch and proximity channels.

Once the halt time has elapsed for the specific activation condition, the **IQS223** will reseed any channels with a active prox or touch condition. Consequently, any active output will also be cleared.



7.2.4 Flick/Swipe time

Bank3: bit 3:2	Flick/Swipe time	[ms]
----------------	------------------	------

The flick/swipe time specifies a time boundary for the maximum period (in ms) allowed for completion of a flick or swipe gesture, starting from the first touch activation. A flick gesture's time ends when the last touch condition is cleared, i.e., no more touches are present on any channels. A swipe gesture's time ends when the swipe distance threshold is reached, i.e., when the distance travelled reached the required swipe length.

Any gesture time longer than the allowed flick/swipe time will be rejected. Please refer to section 7.4 [Gestures](#) regarding the qualification procedure implemented for the **IQS223**.

7.2.5 Tap time

Bank3: bit 3:2	Tap time	[ms]
----------------	----------	------

The tap time specifies a time boundary for the maximum period (in ms) allowed for completion of a tap gesture, starting from the first touch activation. The end time is designated when the last touch condition is cleared, i.e., no more touches are present on any channels.

Any gesture time longer than the allowed tap time will be rejected. Please refer to section 7.4 [Gestures](#) regarding the qualification procedure implemented for the **IQS223**.

7.2.6 Sensing modes

Bank4: bit 3	Sensing mode (Self / Projected)
--------------	---------------------------------

The **IQS223** can function as a self or projected capacitive controller, depending on the application requirement. The **IQS223** is default in self capacitive mode. Set the "Sensing mode" bit, in [OTP bank 4: bit 3](#) to change the self capacitive mode to projected mode. The bias current for projected mode sensing is fixed for the **IQS223** on 5µA.

7.2.1 Charge transfer frequency

Bank3: bit 2	Charge transfer frequency	[kHz/MHz]
--------------	---------------------------	-----------

The **IQS223** provides two charge transfer frequencies for both self and projected mode operation. Applications that require extra sensitivity (for example large electrodes with thick overlays) can employ the slower option. The lower charge transfer frequency can also aid in RF immunity for harsh EM noise environments in combination with increase series resistance on CRX lines. Set the "Charge transfer frequency" bit option, in [OTP Bank 4: bit 2:1](#) in order to use the alternative (lower) frequency option.

7.2.2 Flick/Swipe threshold

Bank3: bit 2	Flick/Swipe threshold	[% of slider length]
--------------	-----------------------	----------------------

The flick and swipe thresholds are validated according to the distance travelled on the electrodes. If the traveling distance is reached (within the time specification) the gesture is successful and will output on the corresponding pin. Please refer to section 7.4 [Gestures](#) regarding the qualification procedure implemented for the **IQS223**.



7.3 Output Pins

The **IQS223** provides 4 output pins with the following properties:

Table 7.2 Output pin properties and logic descriptions

Pin	Pin name	Function	Logic level	Default pulse length
5	TX / POUT	Sensor transmit pin / Digital Output	Active high	Duration of prox condition or halt time for prox or halt time for touch conditions
14	OUT_TAP / HOLD	Digital Output	Active high	Tap = 80ms; Hold = Holding period or halt time for touch
15	OUT_DIR_2	Digital Output	Active high	80ms
16	OUT_DIR_1	Digital Output	Active high	80ms

If the **IQS223** is operating in self capacitive mode, pin 5 is only a proximity output (P_OUT). This output (active high), will indicate active proximity events and can be used as an interrupt pin to a host MCU to indicate **IQS223** normal power mode operation and possible imminent gesture outputs.

If the **IQS223** is operating in projected capacitive mode, pin 5 is time shared between the transmit signal (TX) and the proximity output (POUT) signal. The TX signal will enjoy a higher priority than an active POUT output but the high-level charge pulse period of the projected TX signal is short enough not to drive the pin high longer than $\sim 0.5\mu\text{s}$ (1MHz). The total transmit time of successive pulses is also short enough to be ignored/rejected with the correct analogue or digital interface implementation towards a host MCU if required.

7.3.2 CRX pins during unused periods

During the charge transfer process, the inactive sensor pins (CRX electrodes that are not being processed during the current conversion) are grounded to decrease the effects of noise-coupling into the system. Grounding these traces is useful in applications with long tracks between IC and sense electrode. This is also to the advantage of battery powered applications that requires a better ground reference for the user when touching the active sensor electrodes and the GND connected ones simultaneously.



7.4 Gestures

The IQS223 implements tap and hold gestures as well as one-dimensional flick/swipe gestures.

7.4.1 Flick and Swipe gestures

The difference between flick and swipe gestures are defined as follow:

- > **Flick:** A quick sliding movement of the finger in a certain linear direction on the electrodes and removing it afterwards in order to break finger contact on the slider surface.
- > **Swipe:** A quick sliding movement of the finger in a certain linear direction on the electrodes without requiring the removal or breaking of finger contact with the slider surface afterwards.

Tap and hold gestures are evaluated on the touch conditions on any of the touch channels.

Each gesture's requirements are explained in the following sub sections.

7.4.2 Tap gesture

The IQS223 implements an adjustable tap timeout for configurable tap recognition. The timer is started once a touch event is recognised. A tap event will be registered based on two conditions:

- > 1st condition: The touch event must be released (cleared) before the timer reaches the tap time.
- > 2nd condition: The coordinate change must be less than half of the flick/swipe threshold.

The tap timeout can be adjusted with the "Tap Timer" bits in OTP bank 3: bit1:0.

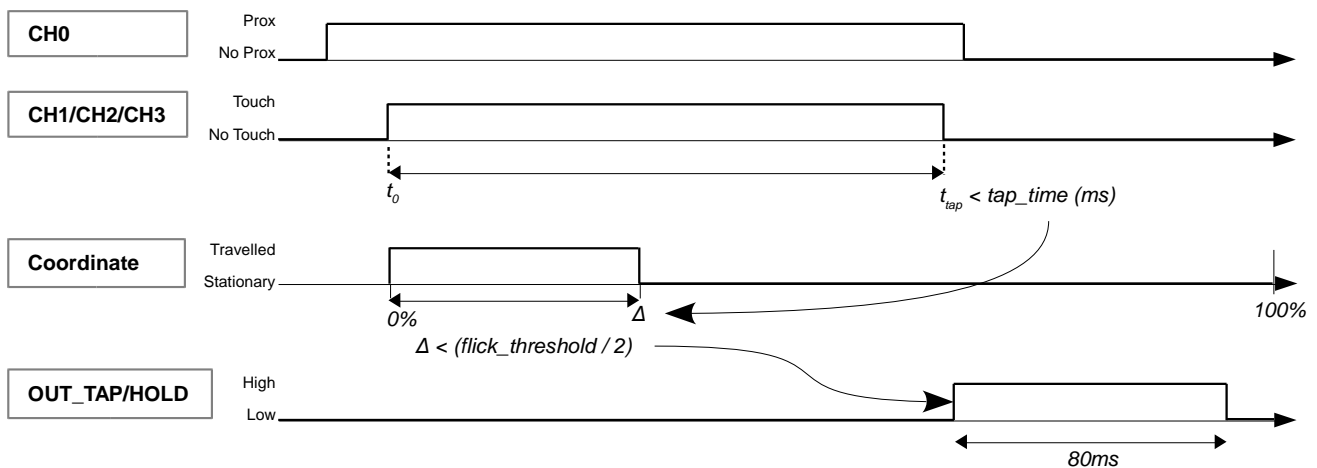

Figure 7.1 Tap gesture qualification and output pulse description

7.4.3 Hold gesture

The Hold gesture is also qualified with 2 mandatory conditions:

- > 1st condition: The touch event must persist (without interruption) for a period longer than the tap and flick times.
- > 2nd condition: The relative change in coordinates experienced, from the start of the touch event until the hold gesture is actuated, must be less than that of the flick threshold.

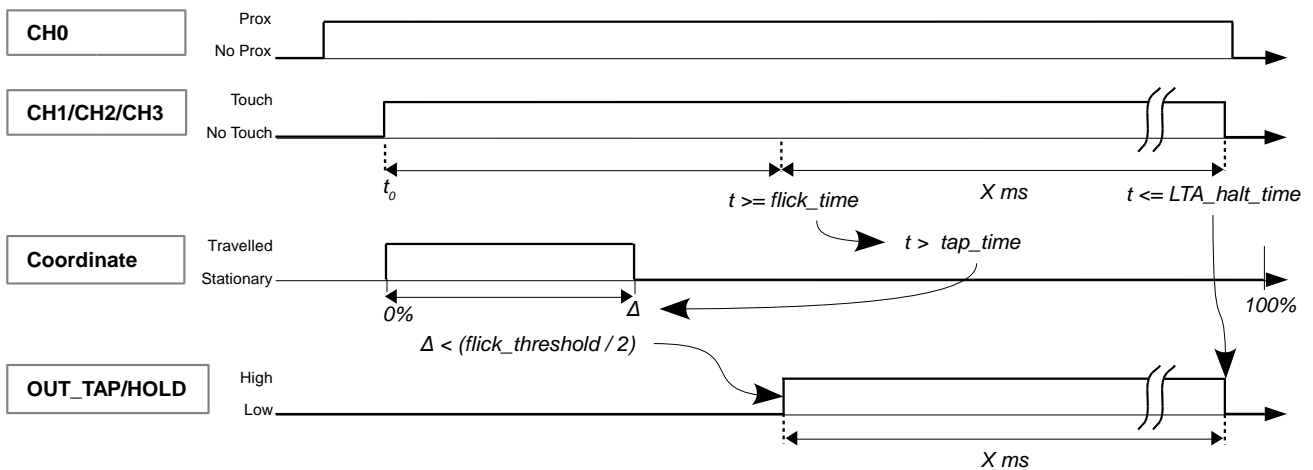

Figure 7.2 Hold gesture qualification and output pulse description

7.4.4 Flick gesture

The **IQS223** implements an adjustable flick gesture recognition. The flick gesture option is the default gesture type of the **IQS223**. The user has the option to specify the flick time (OTP bank 3: bit 3:2) as well as a flick threshold (OTP bank 4: bit 1:0).

A flick gesture is qualified if the following two conditions is met:

- > 1st condition: The gesture time, measured from the first touch condition until the last touch condition clears, must be shorter than the flick time constraint option selected in OTP bank 3: bit 3:2.
- > 2nd condition: The coordinate travel is more than the minimum required flick threshold option selected in OTP bank 4: bit 1:0.

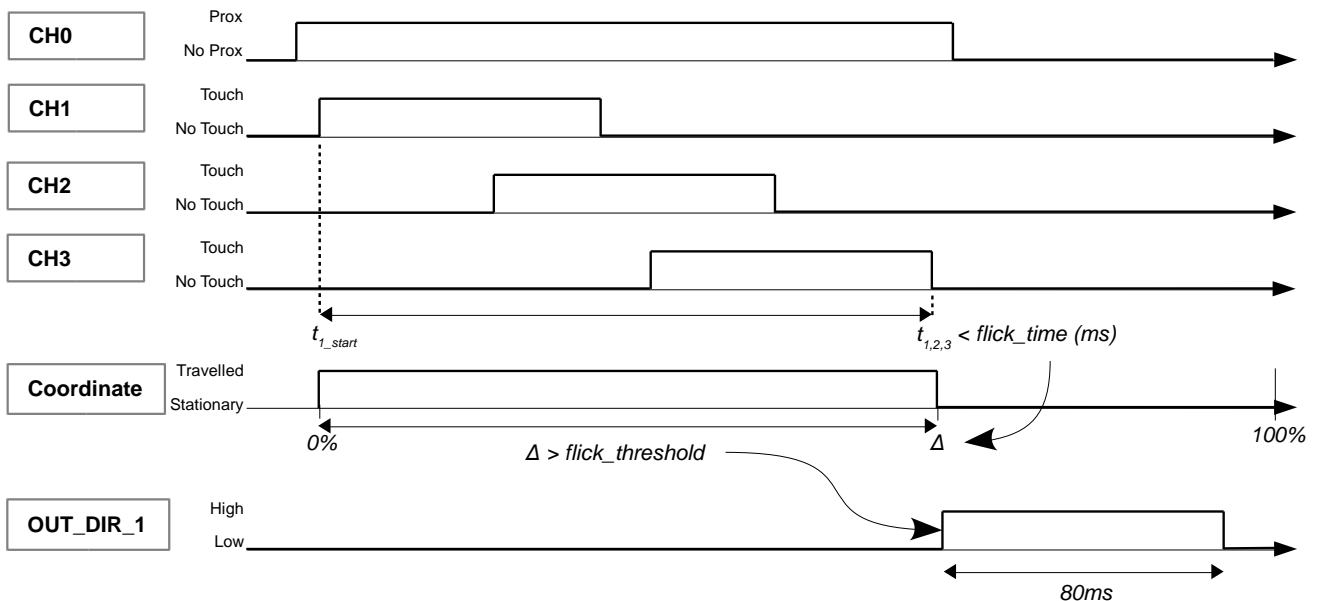

Figure 7.3 Direction 1 Flick gesture qualification and output pulse description

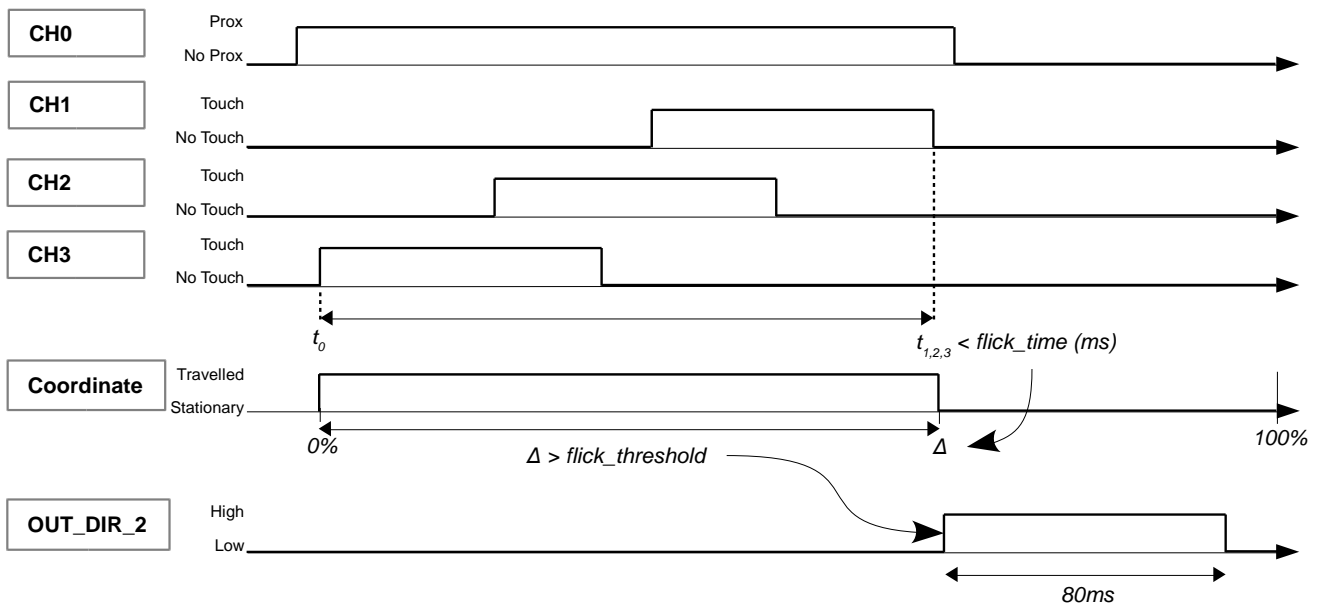

Figure 7.4 Direction 2 Flick gesture qualification and output pulse description

As illustrated above in Figure 7.3 and Figure 7.4, all touch conditions must be cleared before the flick gesture can be validated according to the timing and threshold specifications and output on the relevant output pin.

7.4.5 Swipe gesture

The **IQS223** implements an adjustable swipe gesture recognition. The user can select the swipe option by setting the “Gesture type bit”, in OTP bank 2: bit 3. The user has the option to specify the swipe threshold with “Flick/Swipe Threshold” bits in OTP bank 4 to set the amount that the coordinates must be adjusted by the user before the swipe event is set. There is also the option to adjust the time in which the coordinate must move by setting the “Flick/Swipe Timer” in OTP bank 3: bit 3-2.

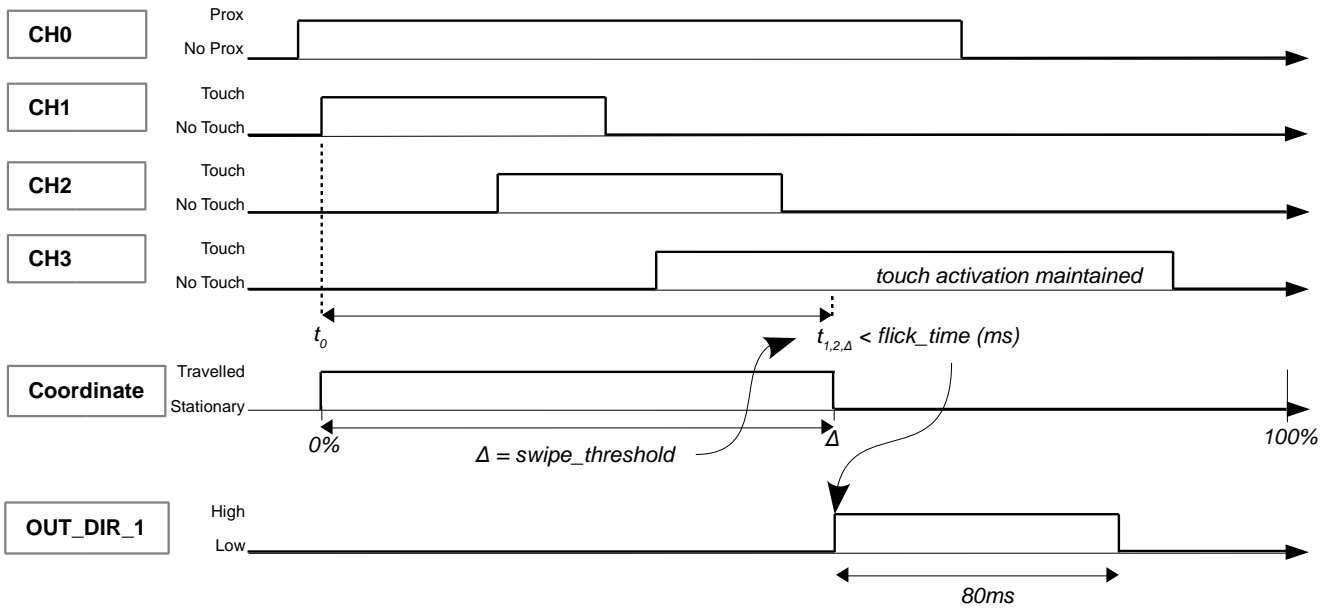

Figure 7.5 Direction 1 Swipe gesture qualification and output pulse description

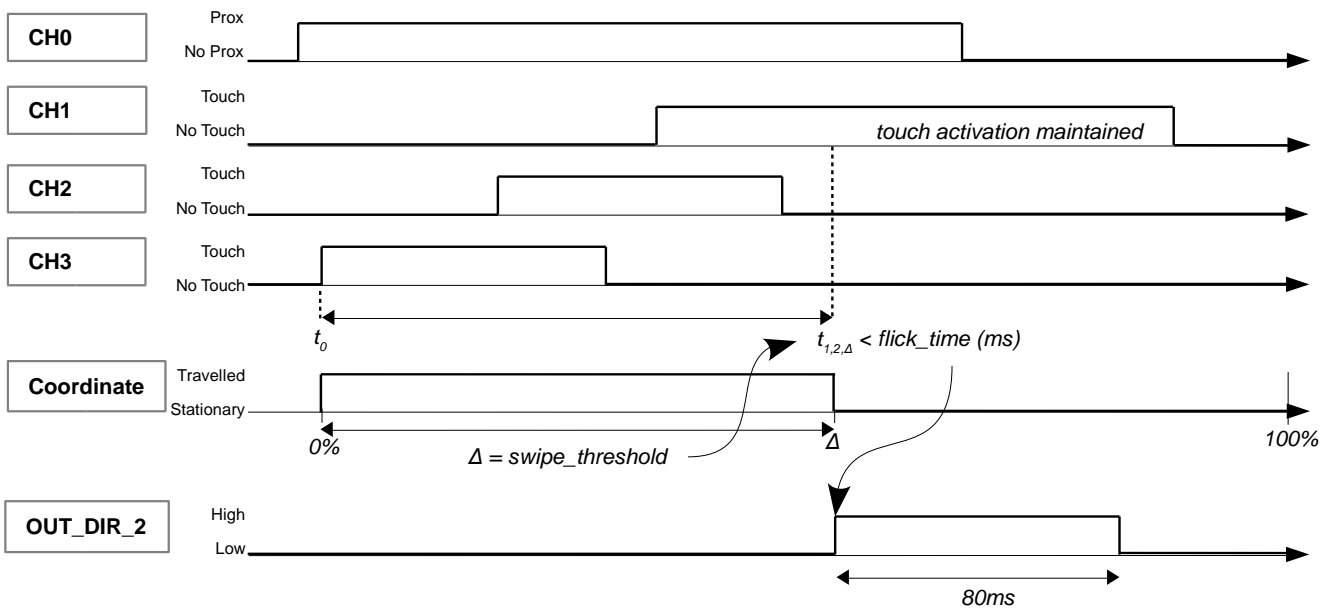

Figure 7.6 Direction 2 Swipe gesture qualification and output pulse description



8 Specifications

8.1 Absolute Maximum Specifications

The following absolute maximum parameters are specified for the device:

Exceeding these maximum specifications may cause damage to the device.

- > Operating temperature -20°C to 85°C
- > Supply Voltage (VDDHI – GND) 3.6V
- > Maximum pin voltage VDDHI + 0.5V (may not exceed VDDHI max)
- > Maximum continuous current (for I/O pins) 10mA
- > Minimum pin voltage GND - 0.5V
- > Minimum power-on slope 100V/s
- > ESD protection ±8kV (Human body model)

8.2 Current measurements

Please note:

- > The measurements below were taken for default device operation with suggested electrode layouts.
- > These measurements do not reflect current consumptions with active prox, touch or loads driven with IO outputs.
- > Alternative sensor setups (target, base, charge transfer frequency) may result in slightly higher or lower current consumptions.

Table 8.1 IQS223 Self capacitive general operating conditions

Description	Conditions	Parameter	Min.	Typ.	Max.	Unit
Supply voltage		V _{DDHI}	1.8	3.3	3.6	V
Internal regulator output	1.8 ≤ V _{DDHI} ≤ 3.6	V _{REG}	1.61	1.66	1.71	V
Normal power mode	14ms / 71.4Hz	NP	189	192		µA
Low power mode 16	16ms / 62.5Hz	LP16	20.3	20.8		µA
Low power mode 32	32ms / 31Hz	LP32	11.4	11.7		µA
Low power mode 48	48ms / 21Hz	LP48	7.7	8.1		µA
Low power mode 64	64ms / 15.6Hz	LP64	6.0	6.4		µA
Low power mode 80	80ms / 12.5Hz	LP80	5.2	5.6		µA
Low power mode 112	112ms / 9Hz	LP112	4.0	4.4		µA
Low power mode 160	160ms / 6.25Hz	LP160	2.9	3.2		µA



Table 8.2 IQS223 Projected capacitive general operating conditions

Description	Conditions	Parameter	Min.	Typ	Max	Unit
Supply voltage	3.3V	V _{DDHI}	1.8	3.3	3.6	V
Internal regulator output	1.8 ≤ V _{DDHI} ≤ 3.6	V _{REG}	1.61	1.66	1.71	V
Normal power mode	14ms / 71.4Hz	NP	158	161		μA
Low power mode 16	16ms / 62.5Hz	LP16	20.0	20.4		μA
Low power mode 32	32ms / 31Hz	LP32	11.1	11.3		μA
Low power mode 48	48ms / 21Hz	LP48	7.7	8.0		μA
Low power mode 64	64ms / 15.6Hz	LP64	6.0	6.3		μA
Low power mode 80	80ms / 12.5Hz	LP80	5.2	5.4		μA
Low power mode 112	112ms / 9Hz	LP112	4.0	4.2		μA
Low power mode 160	160ms / 6.25Hz	LP160	2.9	3.1		μA

Table 8.3 Start-up and shut-down slope Characteristics

DESCRIPTION	Conditions	PARAMETER	MIN	MAX	UNIT
Power On Reset	V _{DDHI} Slope ≥ 100V/s @25°C	POR		1.6	V
Brown Out Detect	V _{DDHI} Slope ≥ 100V/s @25°C	BOD	1.10		V

Table 8.4 Electrode Specifications – Self Capacitance

DESCRIPTION	Conditions	PARAMETER	MAX	UNIT
Parasitic Capacitance CX to GND		C _P	120	pF
Series Resistor	C _P = 120pF	R _S	10	kΩ

Table 8.5 Electrode Specifications – Projected Capacitance

DESCRIPTION	Conditions	PARAMETER	MIN	MAX	UNIT
Parasitic Capacitance TX to GND		C _{PTX}		100	pF
Parasitic Capacitance CRX to GND		C _{PRX}		100	pF
Projected Capacitance		C _M	0.1	10	pF
Series Resistor		R _{STX}		10	kΩ
Series Resistor	C _M = 1pF	R _{SRX}		1	kΩ



9 Packaging Information

9.1 Package and footprint specifications

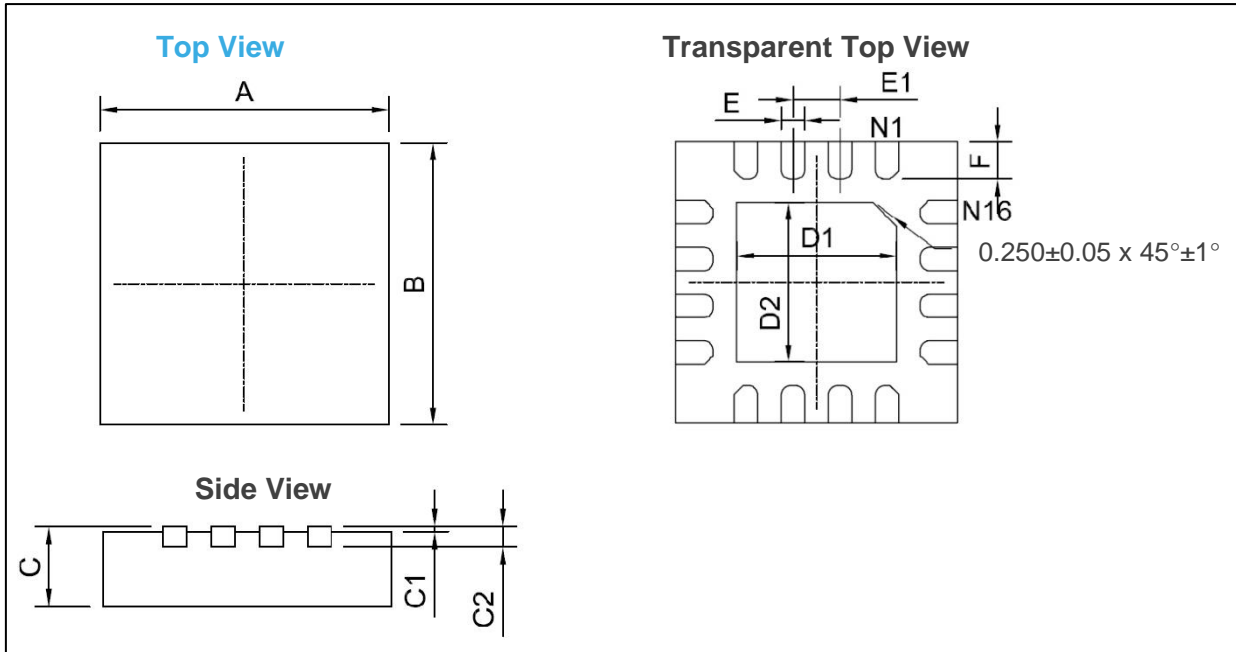

Figure 9.1 QFN-16 Package Dimensions

Table 9.1 QFN-16 Package Dimensions

Dimension	[mm]	Dimension	[mm]
A	3.0±0.1	D1	1.7±0.05
B	3.0±0.1	D2	1.7±0.05
C	0.75±0.05	E	0.25±0.05
C1	0.025±0.025	E1	0.5±0.05
C2	0.203±0.05	F	0.4±0.05

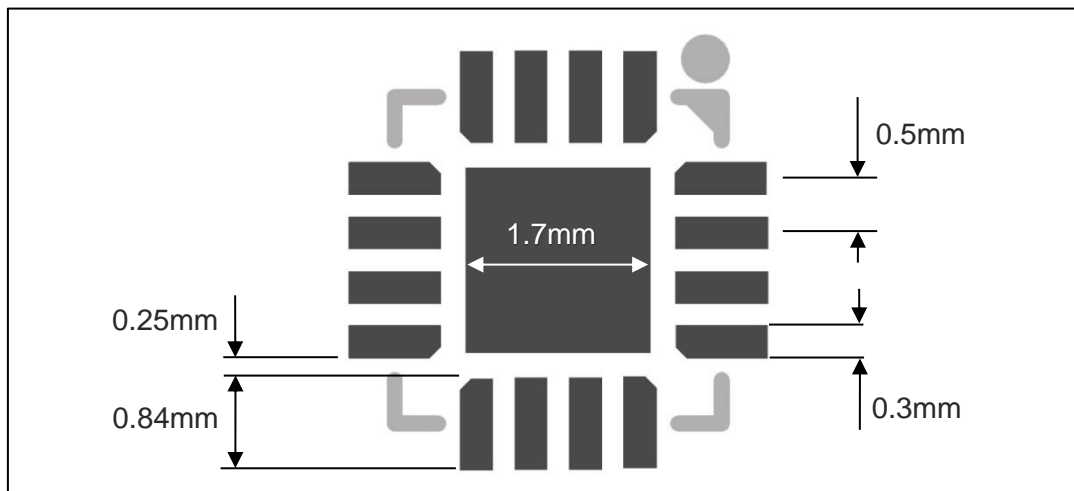

Figure 9.2 QFN-16 Footprint



9.2 Tape and Reel Specification

9.2.1 Tape specification

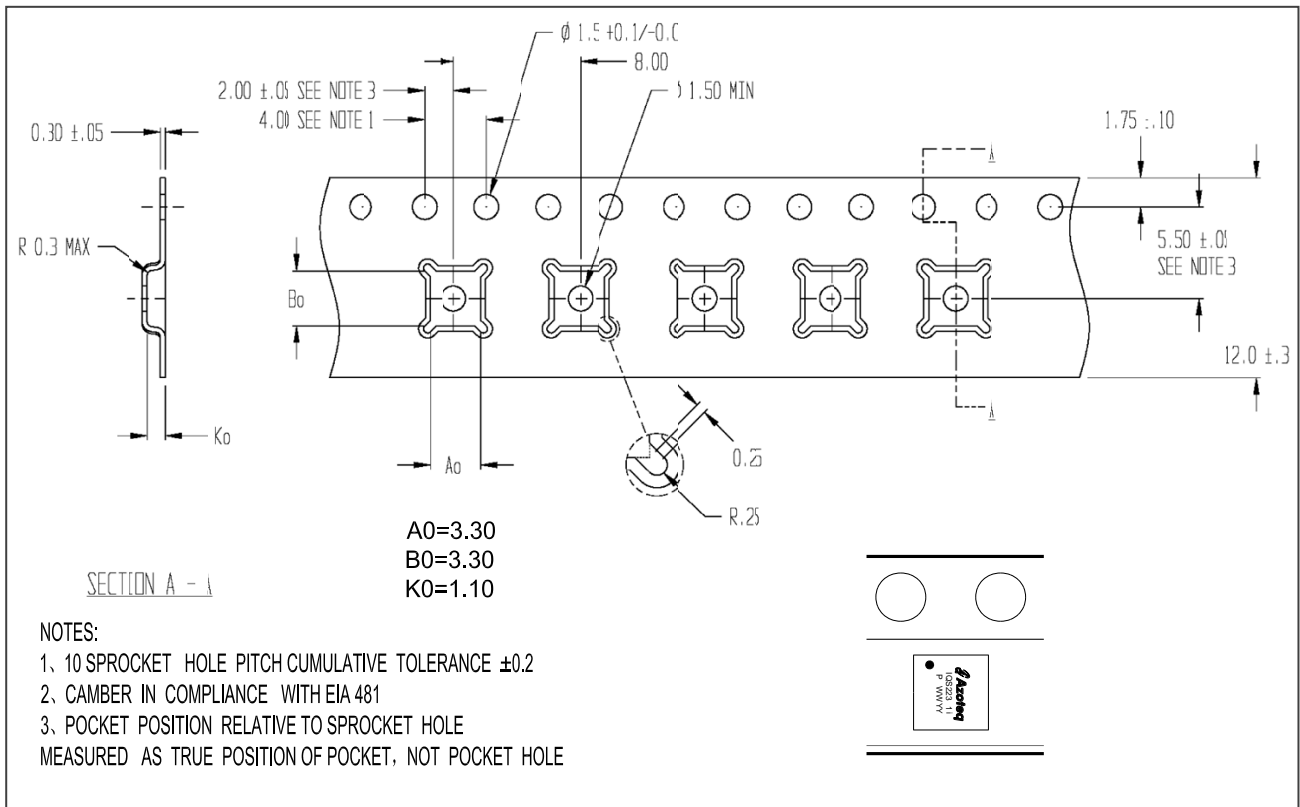

Figure 9.3 Tape specification for IQS223 zzzzzzzz QNR



9.2.2 Cover tape specification

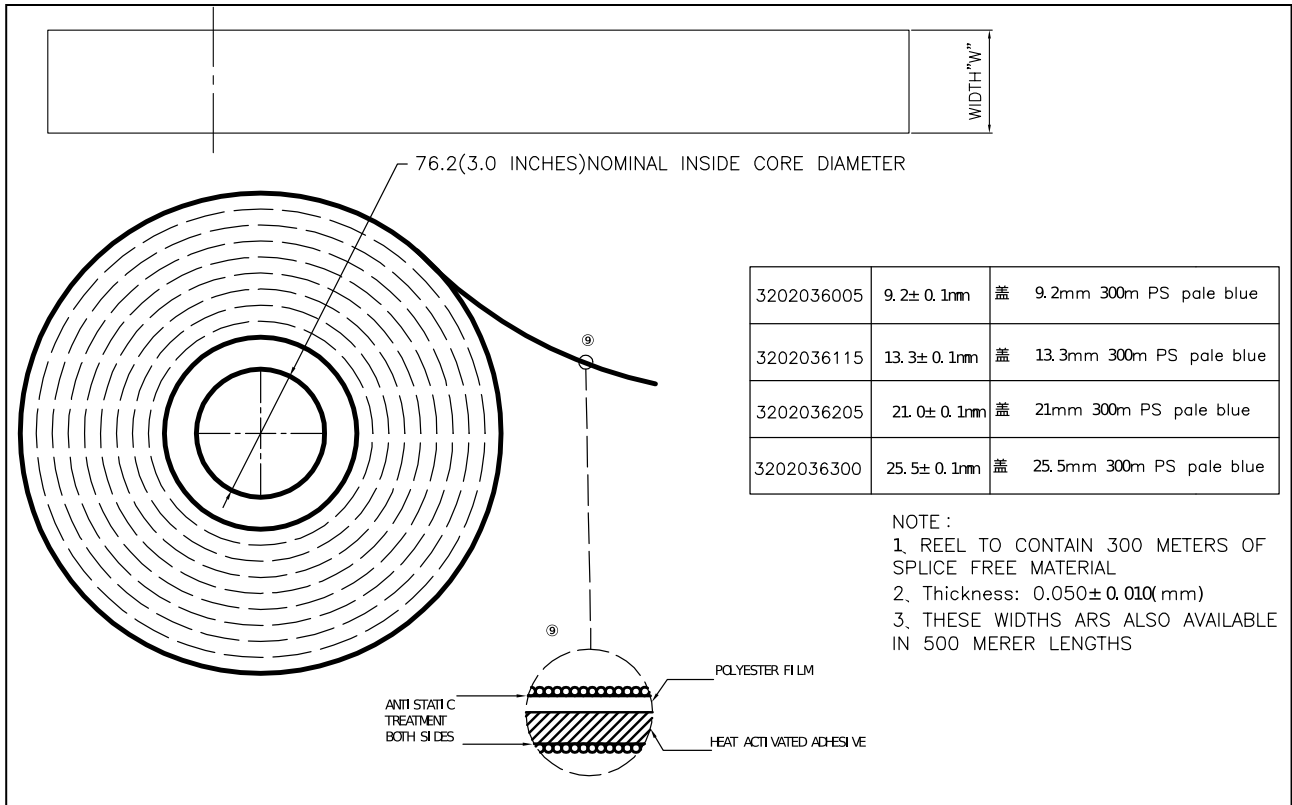

Figure 9.4 Cover tape specification used for IQS223 zzzzzzzz QNR



Reel specification

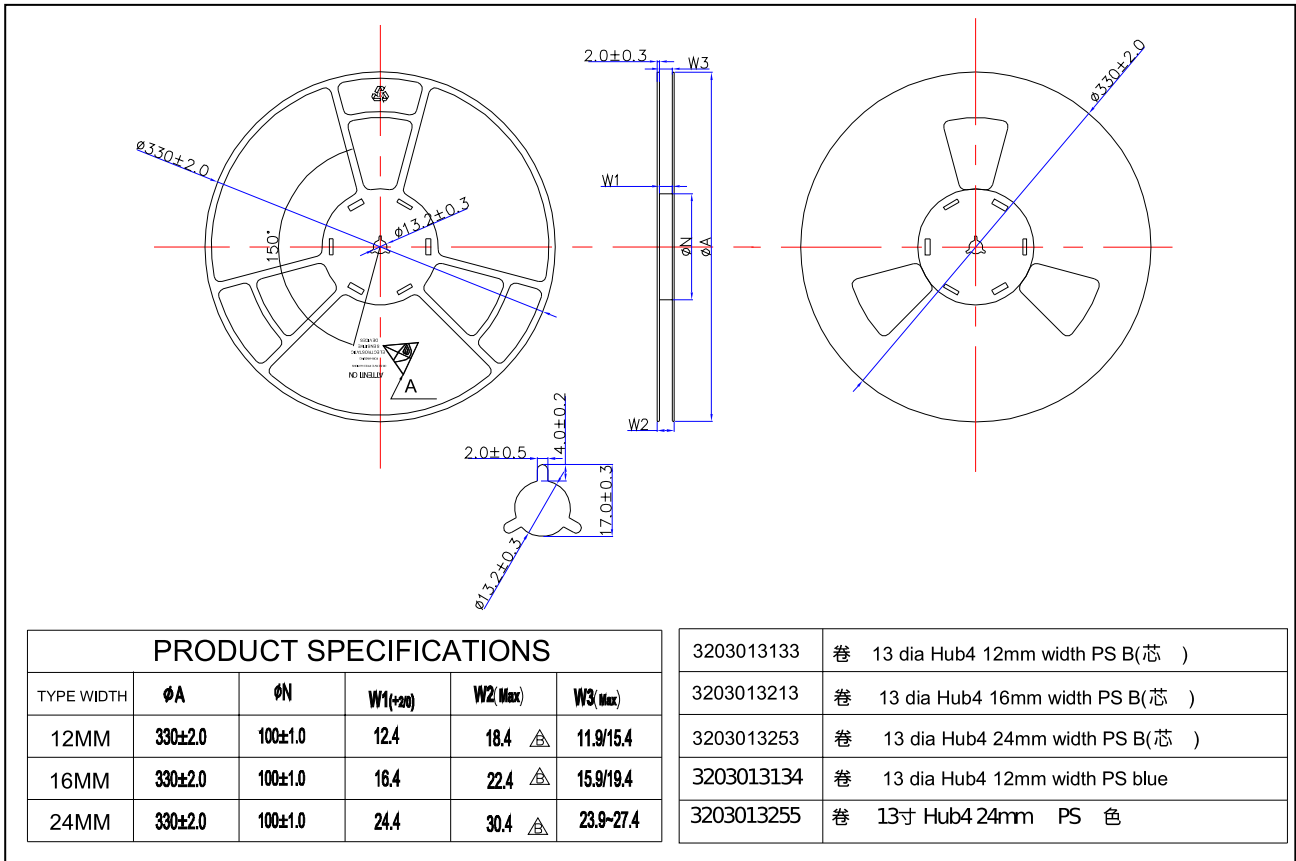

Figure 9.5 12mm width reel used for IQS223 zzzzzzzz QNR packaging

9.3 Package moisture sensitive level qualification

Moisture Sensitivity Level (MSL) relates to the packaging and handling precautions for some semiconductors. The MSL is an electronic standard for the time period in which a moisture sensitive device can be exposed to ambient room conditions (approximately 30°C/85%RH see J-STD033C for more info) before reflow occur.

Table 9.2 Table MSL qualification

Package	Level (duration)
QFN-16 (3x3)	MSL 1 (Unlimited at ≤30°C/85% RH) Reflow profile peak temperature < 260 °C for < 25 seconds Number of Reflow ≤ 3



10 Device Marking

10.1 Top Marking

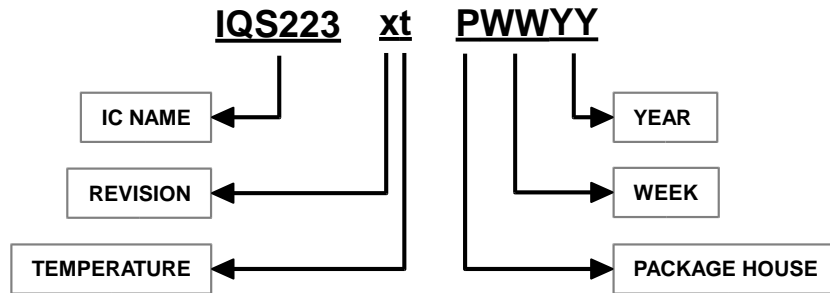

IC NAME	IQS223		
REVISION	x	=	IC Revision Number
TEMPERATURE RANGE	t	=	I: -20°C to 85°C (Industrial)
PACKAGE HOUSE	P	=	1,2,3...(Azoteq internal reference)
DATE CODE	WW	=	Week
	YY	=	Year

11 Ordering Information

Order quantities will be subject to multiples of a full reel. Contact the official distributor for sample quantities. A list of the distributors can be found under the “Distributors” section of www.azoteq.com.

11.1 QFN-16 Package

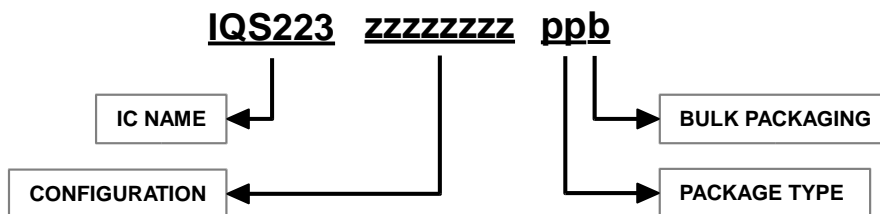

IC NAME	IQS223	=	IQS223
CONFIGURATION	zzzzzzzz	=	Configuration (hexadecimal)
PACKAGE TYPE	QN	=	QFN16
BULK PACKAGING	R	=	Reel - 3000pcs/reel



	USA	Asia	South Africa
Physical Address	6507 Jester Blvd Bldg 5, suite 510G Austin TX 78750 USA	Rm2125, Glittery City Shennan Rd Futian District Shenzhen, 518033 China	1 Bergsig Avenue Paarl 7646 South Africa
Postal Address	6507 Jester Blvd Bldg 5, suite 510G Austin TX 78750 USA	Rm2125, Glittery City Shennan Rd Futian District Shenzhen, 518033 China	PO Box 3534 Paarl 7620 South Africa
Tel	+1 512 538 1995	+86 755 8303 5294 ext 808	+27 21 863 0033
Fax	+1 512 672 8442		+27 21 863 1512
Email	info@azoteq.com	info@azoteq.com	info@azoteq.com

Visit www.azoteq.com

for a list of distributors and worldwide representation.

The following patents relate to the device or usage of the device: US 6,249,089; US 6,952,084; US 6,984,900; US 7,084,526; US 7,084,531; US 8,395,395; US 8,531,120; US 8,659,306; US 8,823,273; US 9,209,803; US 9,360,510; US 9,496,793; US 9,709,614; EP 2,351,220; EP 2,559,164; EP 2,748,927; EP 2,846,465; HK 1,157,080; SA 2001/2151; SA 2006/05363; SA 2014/01541; SA 2015/023634; SA 2017/02224;

AirButton®, Azoteq®, Crystal Driver®, IQ Switch®, ProxSense®, ProxFusion®, LightSense™, SwipeSwitch™, and the  logo are trademarks of Azoteq.

The information in this Datasheet is believed to be accurate at the time of publication. Azoteq uses reasonable effort to maintain the information up-to-date and accurate, but does not warrant the accuracy, completeness or reliability of the information contained herein. All content and information are provided on an “as is” basis only, without any representations or warranties, express or implied, of any kind, including representations about the suitability of these products or information for any purpose. Azoteq disclaims all warranties and conditions with regard to these products and information, including but not limited to all implied warranties and conditions of merchantability, fitness for a particular purpose, title and non-infringement of any third party intellectual property rights. Azoteq assumes no liability for any damages or injury arising from any use of the information or the product or caused by, without limitation, failure of performance, error, omission, interruption, defect, delay in operation or transmission, even if Azoteq has been advised of the possibility of such damages. The applications mentioned herein are used solely for the purpose of illustration and Azoteq makes no warranty or representation that such applications will be suitable without further modification, nor recommends the use of its products for application that may present a risk to human life due to malfunction or otherwise. Azoteq products are not authorized for use as critical components in life support devices or systems. No licenses to patents are granted, implicitly, express or implied, by estoppel or otherwise, under any intellectual property rights. In the event that any of the abovementioned limitations or exclusions does not apply, it is agreed that Azoteq’s total liability for all losses, damages and causes of action (in contract, tort (including without limitation, negligence) or otherwise) will not exceed the amount already paid by the customer for the products. Azoteq reserves the right to alter its products, to make corrections, deletions, modifications, enhancements, improvements and other changes to the content and information, its products, programs and services at any time or to move or discontinue any contents, products, programs or services without prior notification. For the most up-to-date information and binding Terms and Conditions please refer to www.azoteq.com.