

ISSUE 3; April 2016

Description

- LVPECL output crystal oscillator using a high frequency fundamental crystal to give very low jitter. Hermetically sealed ceramic package with a seam sealed metal lid. Replacement for model CFPS-59.



Frequency Parameters

- Frequency: 15.0MHz to 160.0MHz
- Frequency Stability: $\pm 25.00\text{ppm}$ to $\pm 100.00\text{ppm}$
- Ageing: $\pm 3\text{ppm}$ max per year @ 25°C

Electrical Parameters

- Supply Voltage: 2.5V $\pm 5\%$

Operating Temperature Ranges

- 10 to 70°C
- 40 to 85°C

Output Details

- Output Compatibility: LVPECL
- Drive Capability: 50Ω terminated to $V_S - 2.0V$
- Output Voltage Levels:
Output Low (VoL): 1.095V max
Output High (VoH): 1.475V min

Output Control

- Enable/Disable:
Logic '1' (70% V_S min) to pad 1 enables oscillator output.
Logic '0' (30% V_S max) to pad 1 disables oscillator output; the oscillator output goes to the high impedance state.
No connection to pad 1 enables oscillator output.
Standby Current: 10μA max

Noise Parameters

- Phase Jitter (12kHz to 20MHz): 1ps rms max

Environmental Parameters

- Storage Temperature Range: -55 to 125°C
- Shock: MIL-STD-202, Method 213, Condition E: 1000G, 0.5ms, half sine wave.
- Vibration: MIL-STD-883, Method 2007, Condition A: 20G

Ordering Information

- Frequency*
- Model*
- Output
- Frequency Stability (over operating temperature range)*
- Operating Temperature Range*
- Supply Voltage
- (*minimum required)
- Example
100.0MHz IQXO-621
LVPECL $\pm 50\text{ppm}$ -10 to 70C 2.5V

Compliance

- RoHS Status (2011/65/EU): Compliant
- REACH Status: Compliant
- MSL Rating (JDEC-STD-033): Not Applicable

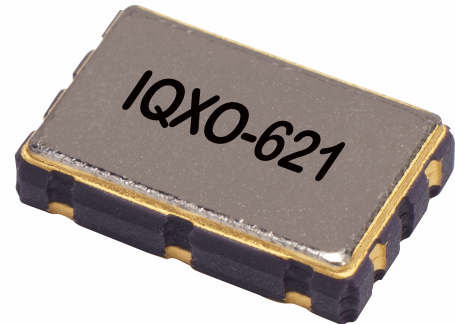

Outline (mm)

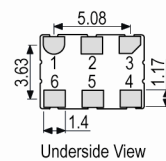
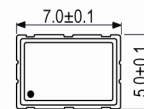

Pad Connections

1. Enable/Disable
2. N/C
3. GND
4. Output +
5. Output -
6. +Vs

Solder Pad Layout

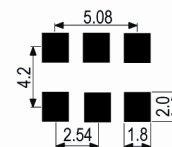

Test Circuit

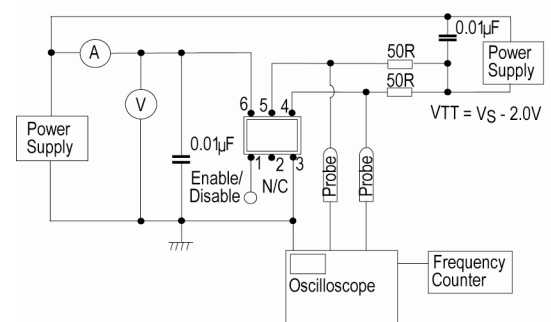

Sales Office Contact Details:

UK: +44 (0)1460 270200

Germany: 0800 1808 443

France: 0800 901 383

USA: +1.760.318.2824

Email: info@iqdfrequencyproducts.com

Web: www.iqdfrequencyproducts.com

Packaging Details

- Pack Style: Bulk Loose in bulk pack
 Pack Size: 100
- Pack Style: Reel Tape & reel in accordance with EIA-481-D
 Pack Size: 1,000

Wave Form

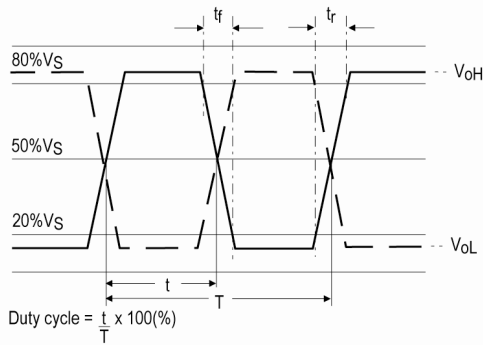

Electrical Specification - maximum limiting values 2.5V ±5%

Frequency Min	Frequency Max	Temperature Range	Stability Min	Current Draw	Rise and Fall Time	Duty Cycle
		°C	ppm	mA	ns	%
15.0MHz	99.999999MHz	-10 to 70	±25.0	70	1	45/55%
		-40 to 85	±25.0	70	1	45/55%
100.0MHz	160.0MHz	-10 to 70	±25.0	70	0.5	45/55%
		-40 to 85	±25.0	70	0.5	45/55%

This document was correct at the time of printing; please contact your local sales office for the latest version.

[Click to view latest version on our website.](#)

Sales Office Contact Details:

UK: +44 (0)1460 270200
 Germany: 0800 1808 443

France: 0800 901 383
 USA: +1.760.318.2824

Email: info@iqdfrequencyproducts.com
 Web: www.iqdfrequencyproducts.com