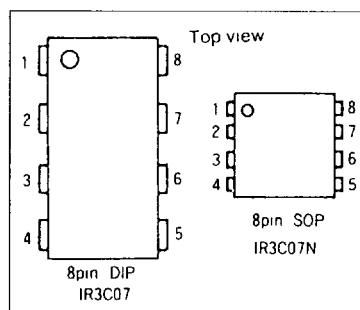


# IR3C07/IR3C07N

## Pin Assignment

IR3C07/IR3C07N		
Pin No.	Symbol	Function
1	OUT	Output
2	Cp	Phase Compensation
3	IM	Monitor input
4	GND	Ground
5	INH	Inhibit input (on/off)
6	So	Operating signal (output)
7	V <sub>CC</sub>	Control Circuit Power Supply
8	V <sub>PS</sub>	Laser Drive Power Supply



## Absolute Maximum Ratings

Parameter	Symbol	Remarks	Ratings	Unit
			IR3C07/IR3C07N	
Supply Voltage	V <sub>CC</sub>	Pin ⑦	10	V
Supply Voltage	V <sub>PS</sub>	Pin ⑧	10	V
Output Current	I <sub>o</sub>	Pin ①	-170	mA
Inhibit Input Voltage	V <sub>I</sub>	Pin ⑤	-0.2 to V <sub>CC</sub>	V
Power Dissipation	P <sub>C</sub>	T <sub>a</sub> ≤ 25°C	800/500	mW
Derating ratio	—	T <sub>a</sub> > 25°C	7.0/4.4	mW/°C
Operating Temperature	T <sub>opr</sub>	—	-30 to +85	°C
Storage Temperature	T <sub>stg</sub>	—	-55 to +150	°C
Output Current	I <sub>os</sub>	Pin ⑥ (on time)	5	mA
Output Applied Voltage	V <sub>os</sub>	Pin ⑥ (off time)	-0.2 to V <sub>CC</sub>	V

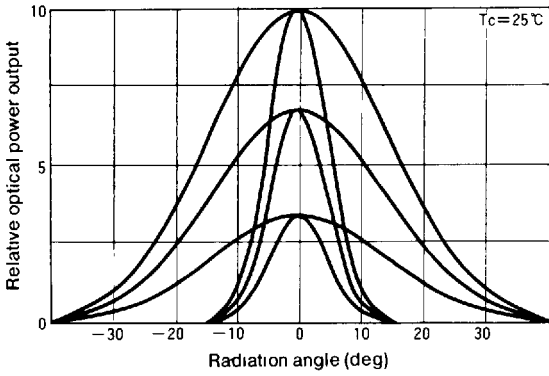
## Electrical Characteristics

(V<sub>CC</sub>=5V, V<sub>PS</sub>=5V, T<sub>a</sub>=25°C)

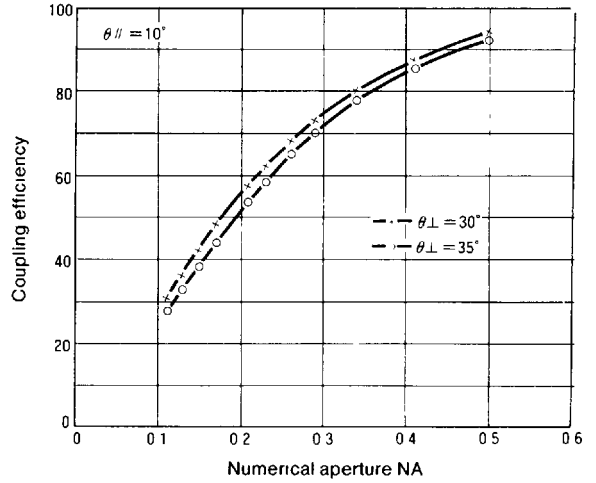
Parameter	Symbol	Condition	Rating			Units
			MIN	TYP	MAX	
Operating Supply Voltage	V <sub>CC</sub>	—	4.5	5.0	5.5	V
Circuit Current	I <sub>CC ON</sub>	V <sub>I</sub> = 5 V	—	3.8	6.8	mA
	I <sub>CC OFF</sub>	V <sub>I</sub> = 0 V	—	5.0	9.0	
Output Voltage	V <sub>O1</sub>	I <sub>o</sub> = -150mA	3.7	4.1	—	V
	V <sub>O2</sub>	I <sub>o</sub> = -100mA	3.8	4.2	—	
	V <sub>O3</sub>	I <sub>o</sub> = -20mA	3.9	4.3	—	
Output Voltage	V <sub>OS1</sub>	I <sub>OS</sub> = 0mA	—	0.05	—	V
	V <sub>OS2</sub>	I <sub>OS</sub> = 2mA	—	0.1	0.4	
Inhibit Input Voltage	V <sub>IH</sub>	V <sub>O</sub> , V <sub>OS</sub> L→H	1.43	1.53	1.63	V
	V <sub>IL</sub>	V <sub>O</sub> , V <sub>OS</sub> H→L	1.23	1.33	1.43	
Voltage Hysteresis	V <sub>IHY</sub>	(V <sub>IH</sub> - V <sub>IL</sub> )	—	200	—	mW
Inhibit Input Current	I <sub>I</sub>	—	—	-0.3	-5	μA
Monitor Input Pin Voltage	V <sub>M</sub>	In equilibrium operation	1.71	1.95	2.19	V
Monitor Input Pin Current	I <sub>M</sub>	—	—	-0.3	-5	μA
Light Output Power Supply Deviation	ΔI <sub>P</sub> /I <sub>P</sub> ΔV <sub>CC</sub>	V <sub>CC</sub> = 5V ± 10%	—	0.2	—	%/V
Light Output Change Range	ΔI <sub>P</sub> /I <sub>P</sub>	T <sub>a</sub> = -20 to +85°C	—	0.2	—	%

# Common Data

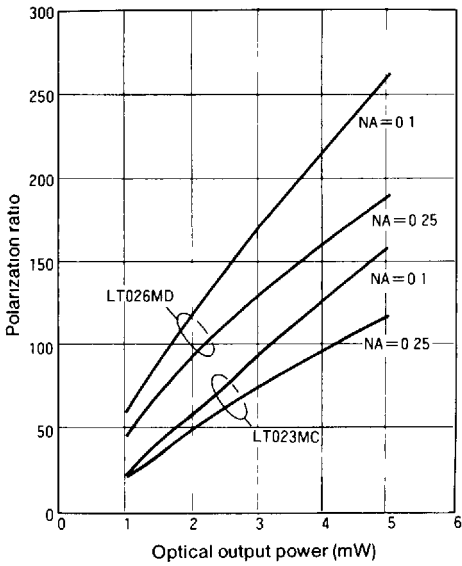
**Fig. 94-1 Optical Power Output Dependence of Far-Field Pattern**



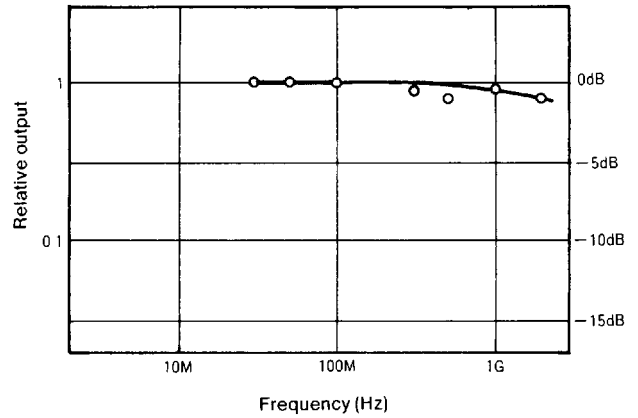
**Fig. 94-4 Coupling Efficiency**



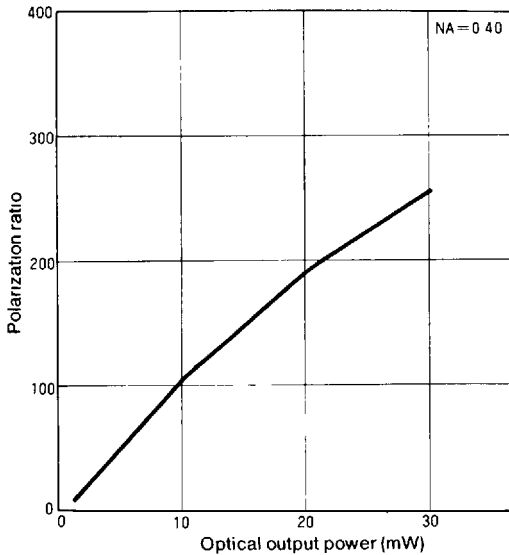
**Fig. 94-2 Polarization Ratio vs. Optical Power Output (LT026 series, LT023 series)**



**Fig. 94-5 Frequency Response**

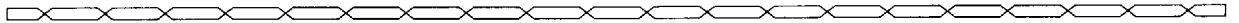


**Fig. 94-3 Polarization Ratio vs. Optical Power Output (LT024 series, LT015 series)**

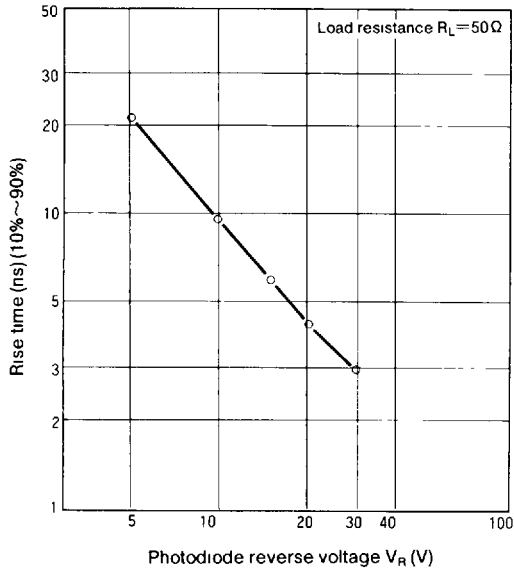


Note All data on this page is typical only, and is not intended as a specification. The shapes of these curves can be used as a general reference, but the actual characteristics will vary from device to device.

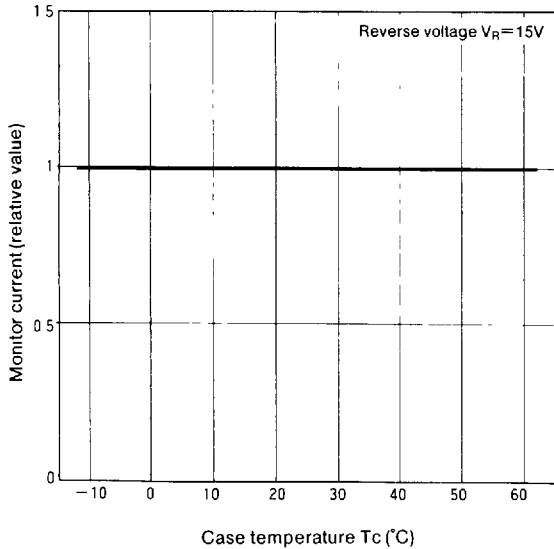
# Built-in PIN Photodiode Characteristics



**Fig. 95-1 Photodiode Frequency Response Characteristic**



**Fig. 95-2 Photodiode Temperature Characteristic**



Note All data on this page is typical only, and is not intended as a specification. The shapes of these curves can be used as a general reference, but the actual characteristics will vary from device to device.

# Outline Dimensions

Unit: mm

Fig. 98-1 Standard Type (C Type)

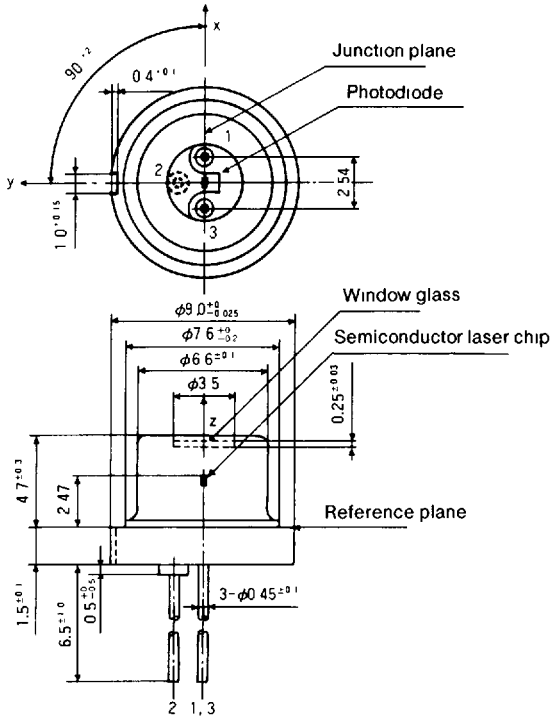


Fig. 98-2 Low-Cap Type (D Type)

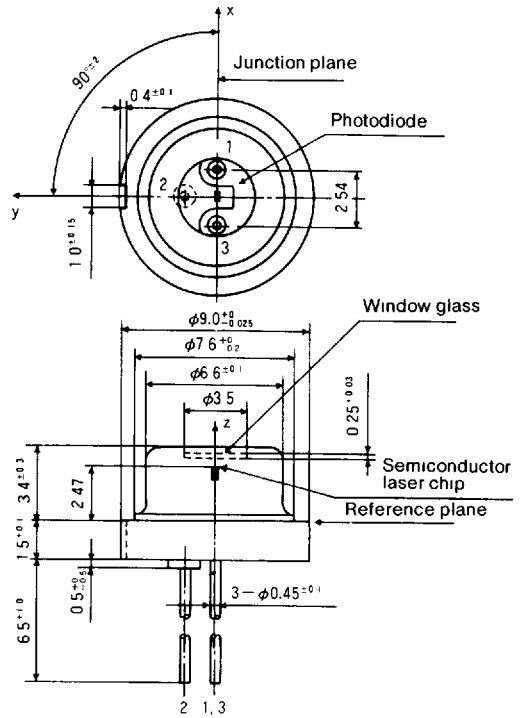


Fig. 98-3 Fin-Equipped Type (F Type)

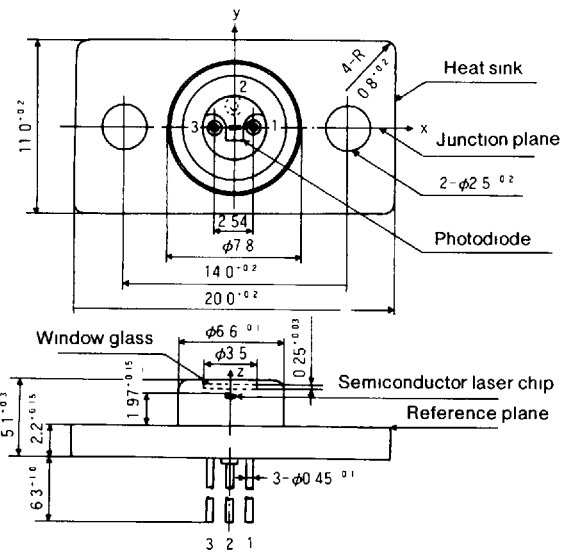
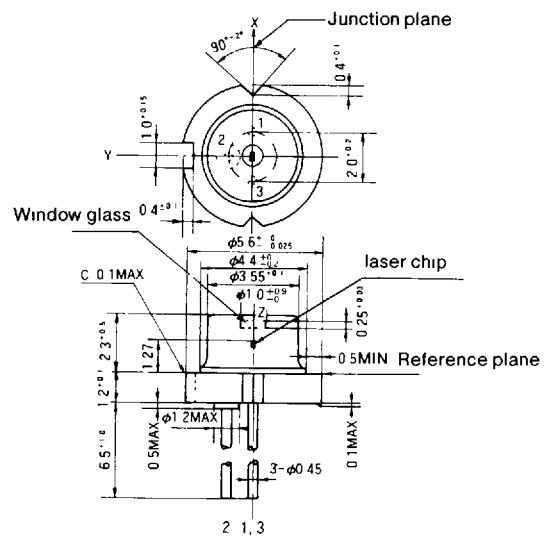


Fig. 98-4 Compact Package Type (S Type)



Terminal connections

