

## N-Channel Power MOSFET 42A, 100Volts

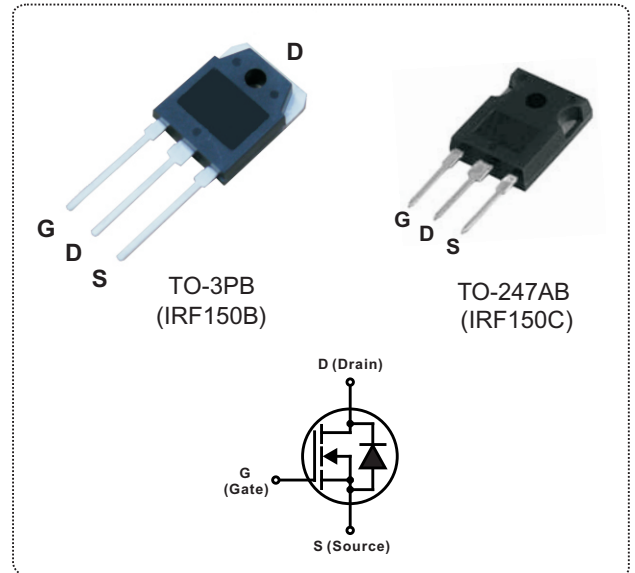
### DESCRIPTION

The Nell **IRF150** is a three-terminal silicon device with current conduction capability of 42A, fast switching speed, low on-state resistance, breakdown voltage rating of 100V, and max. threshold voltage of 4 volts.

They are designed for use in applications such as switched mode power supplies, DC to DC converters, motor control circuits, UPS and general purpose switching applications.

### FEATURES

- $R_{DS(ON)} = 0.055\Omega @ V_{GS} = 10V$
- Ultra low gate charge(110nC Max.)
- Low reverse transfer capacitance ( $C_{RSS} = 230pF$  typical)
- Fast switching capability
- 100% avalanche energy specified
- Improved dv/dt capability
- 175°C operation temperature



### PRODUCT SUMMARY

$I_D$ (A)	42
$V_{DSS}$ (V)	100
$R_{DS(ON)}$ ( $\Omega$ )	0.055 @ $V_{GS} = 10V$
$Q_G$ (nC) max.	110

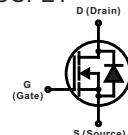
### ABSOLUTE MAXIMUM RATINGS ( $T_C = 25^\circ C$ unless otherwise specified)

SYMBOL	PARAMETER	TEST CONDITIONS	VALUE	UNIT
$V_{DSS}$	Drain to Source voltage	$T_J = 25^\circ C$ to $150^\circ C$	100	
$V_{DGR}$	Drain to Gate voltage	$R_{GS} = 20K\Omega$	100	V
$V_{GS}$	Gate to Source voltage		$\pm 20$	
$I_D$	Continuous Drain Current ( $V_{GS} = 10V$ )	$T_C = 25^\circ C$	42	A
		$T_C = 100^\circ C$	30	
$I_{DM}$	Pulsed Drain current(Note 1)		160	
$I_{AR}$	Avalanche current(Note 1)		22	
$E_{AR}$	Repetitive avalanche energy(Note 1)	$I_{AR} = 22A, R_{GS} = 50\Omega, V_{GS} = 10V$	16	mJ
$E_{AS}$	Single pulse avalanche energy(Note 2)	$I_{AS} = 22A, L = 1.7mH$	420	
dv/dt	Peak diode recovery dv/dt(Note 3)		5.0	V / ns
$P_D$	Total power dissipation	$T_C = 25^\circ C$	160	W
	Derate above $25^\circ C$		1.1	W / $^\circ C$
$T_J$	Operation junction temperature		-55 to 175	
$T_{STG}$	Storage temperature		-55 to 175	$^\circ C$
$T_L$	Maximum soldering temperature, for 10 seconds	1.6mm from case	300	
	Mounting torque, #6-32 or M3 screw		10 (1.1)	lbf-in (N·m)

Note: 1. Repetitive rating: pulse width limited by junction temperature.  
 2.  $I_{AS} = 22A, L = 1.7mH, V_{DD} = 50V, R_G = 25\Omega$ , starting  $T_J = 25^\circ C$ .  
 3.  $I_{SD} \leq 22A, di/dt \leq 180A/\mu s, V_{DD} \leq V_{(BR)DSS}$ , starting  $T_J < 150^\circ C$ .

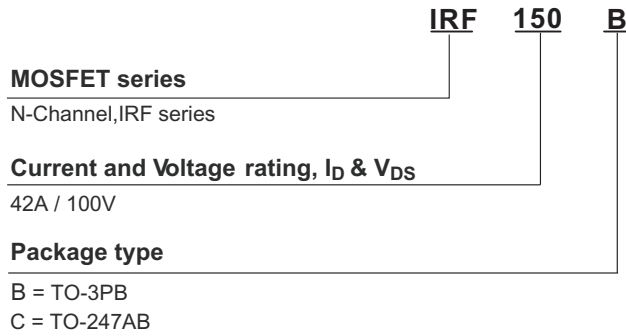
THERMAL RESISTANCE						
SYMBOL	PARAMETER	MIN.	TYP.	MAX.	UNIT	
$R_{th(j-c)}$	Thermal resistance, junction to case			0.95	°C/W	
$R_{th(c-s)}$	Thermal resistance, case to heat sink		0.24			
$R_{th(j-a)}$	Thermal resistance, junction to ambient			40		

ELECTRICAL CHARACTERISTICS ( $T_C = 25^\circ\text{C}$ unless otherwise specified)						
SYMBOL	PARAMETER	TEST CONDITIONS	MIN.	TYP.	MAX.	UNIT
◎ STATIC						
$V_{(BR)DSS}$	Drain to source breakdown voltage	$I_D = 250\mu\text{A}, V_{GS} = 0\text{V}$	100			V
$\Delta V_{(BR)DSS}/\Delta T_J$	Breakdown voltage temperature coefficient	$I_D = 1\text{mA}, V_{DS} = V_{GS}$		0.11		V/°C
$I_{DSS}$	Drain to source leakage current	$V_{DS} = 100\text{V}, V_{GS} = 0\text{V}$			25.0	μA
		$V_{DS} = 80\text{V}, V_{GS} = 0\text{V}$	$T_C = 125^\circ\text{C}$		250	
$I_{GSS}$	Gate to source forward leakage current	$V_{GS} = 20\text{V}, V_{DS} = 0\text{V}$			100	nA
	Gate to source reverse leakage current	$V_{GS} = -20\text{V}, V_{DS} = 0\text{V}$			-100	
$R_{DS(ON)}$	Static drain to source on-state resistance	$I_D = 25\text{A}, V_{GS} = 10\text{V}$			0.055	Ω
$V_{GS(TH)}$	Gate threshold voltage	$V_{GS} = V_{DS}, I_D = 250\mu\text{A}$	2.0		4.0	V
$g_{fs}$	Forward transconductance	$V_{DS} = 25\text{V}, I_D = 25\text{A}$	13			S
◎ DYNAMIC						
$C_{ISS}$	Input capacitance	$V_{DS} = 25\text{V}, V_{GS} = 0\text{V}, f = 1\text{MHz}$		1900		pF
$C_{OSS}$	Output capacitance			450		
$C_{RSS}$	Reverse transfer capacitance			230		
$t_{d(ON)}$	Turn-on delay time	$V_{DD} = 50\text{V}, V_{GS} = 10\text{V}$ $I_D = 22\text{A}, R_G = 3.6\Omega, R_D = 2.9\Omega$ (Note 1,2)		11		ns
$t_r$	Rise time			56		
$t_{d(OFF)}$	Turn-off delay time			45		
$t_f$	Fall time			40		
$Q_G$	Total gate charge	$V_{DD} = 80\text{V}, V_{GS} = 10\text{V}$ $I_D = 22\text{A},$ (Note 1,2)			110	nC
$Q_{GS}$	Gate to source charge				15	
$Q_{GD}$	Gate to drain charge (Miller charge)				58	
$L_D$	Internal drain inductance	Between lead, 6mm(0.25") form package and center of die contact		5		nH
$L_S$	Internal source inductance			13		

SOURCE TO DRAIN DIODE RATINGS AND CHARACTERISTICS ( $T_C = 25^\circ\text{C}$ unless otherwise specified)						
SYMBOL	PARAMETER	TEST CONDITIONS	MIN.	TYP.	MAX.	UNIT
$V_{SD}$	Diode forward voltage	$I_{SD} = 42\text{A}, V_{GS} = 0\text{V}$			2.5	V
$I_S (I_{SD})$	Continuous source to drain current	Integral reverse P-N junction diode in the MOSFET 			42	A
$I_{SM}$	Pulsed source current				160	
$t_{rr}$	Reverse recovery time	$I_{SD} = 42\text{A}, V_{GS} = 0\text{V},$ $dI_F/dt = 100\text{A}/\mu\text{s}$		220	330	ns
$Q_{rr}$	Reverse recovery charge			1.9	2.9	μC

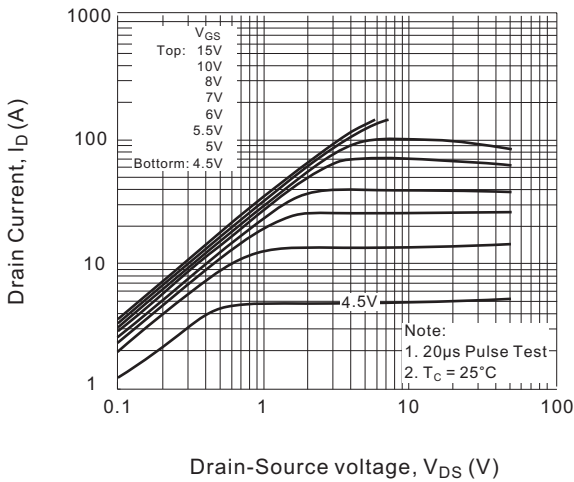
Note: 1. Pulse test: Pulse width  $\leq 300\mu\text{s}$ , duty cycle  $\leq 2\%$ .  
2. Essentially independent of operating temperature.

## ORDERING INFORMATION SCHEME

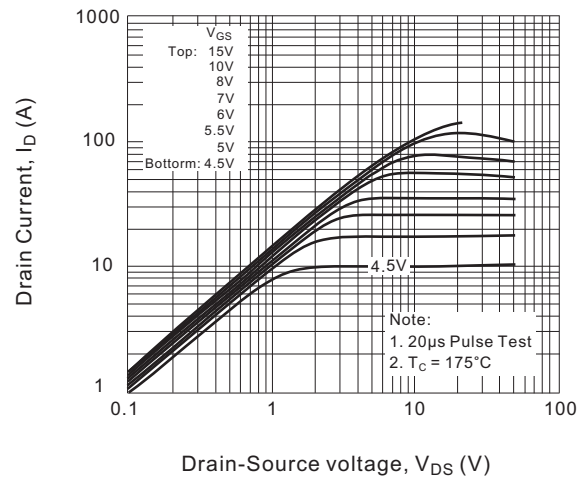


## ■ TYPICAL CHARACTERISTICS

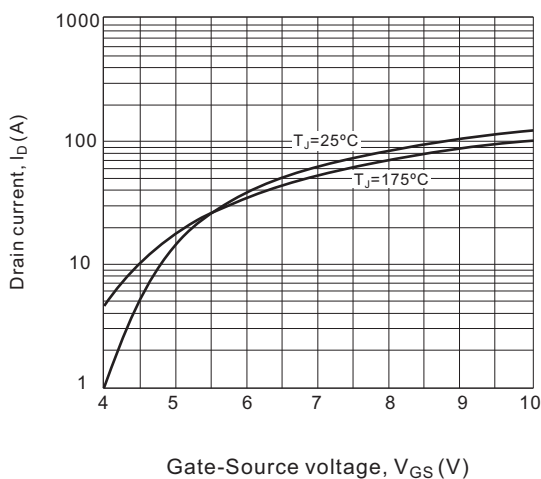
**Fig.1 Typical output characteristics,  $T_C=25^\circ\text{C}$**



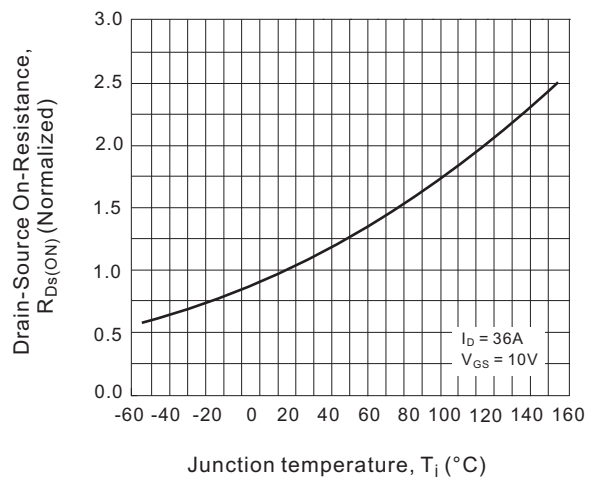
**Fig.2 Typical output characteristics,  $T_C=175^\circ\text{C}$**



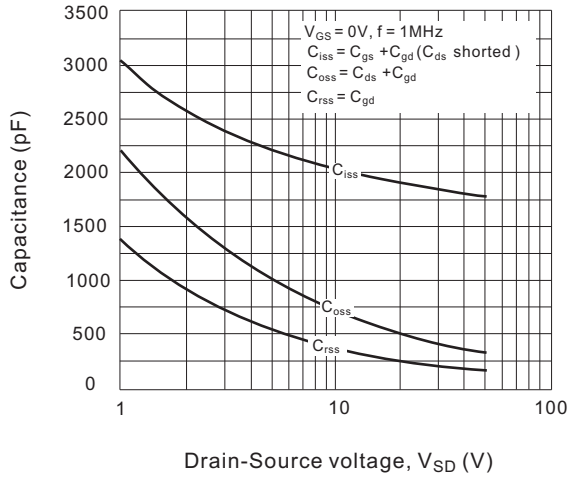
**Fig.3 Typical transfer characteristics**



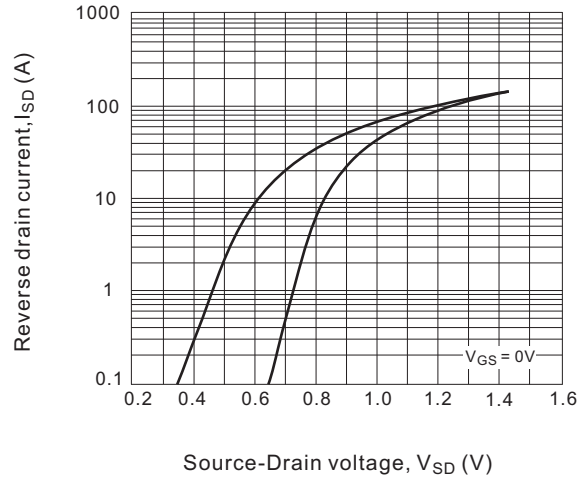
**Fig.4 Normalized On-Resistance vs. Temperature**



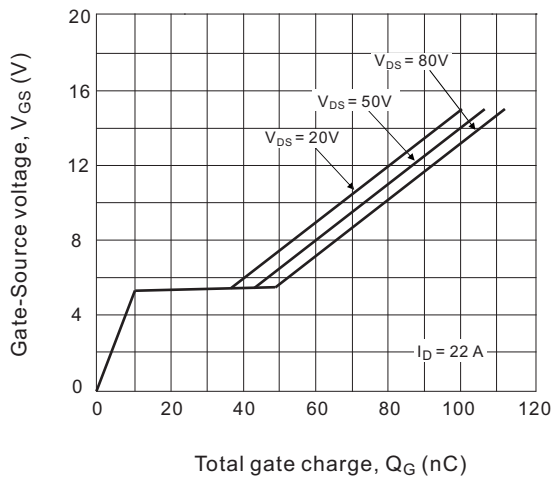
**Fig.5 Typical capacitance vs. Drain-to-Source voltage**



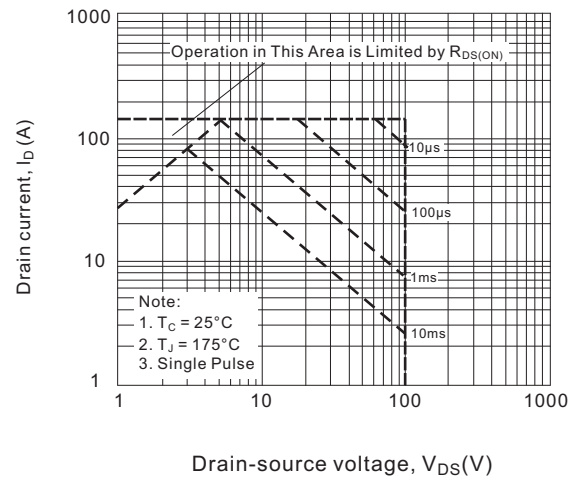
**Fig.6 Typical source-drain diode forward voltage**



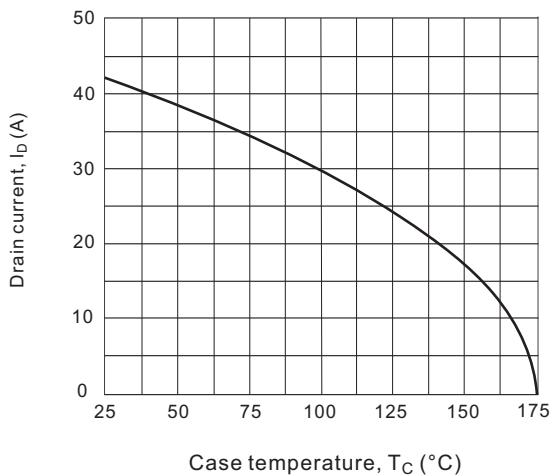
**Fig.7 Typical gate charge vs. gate-to-source voltage**



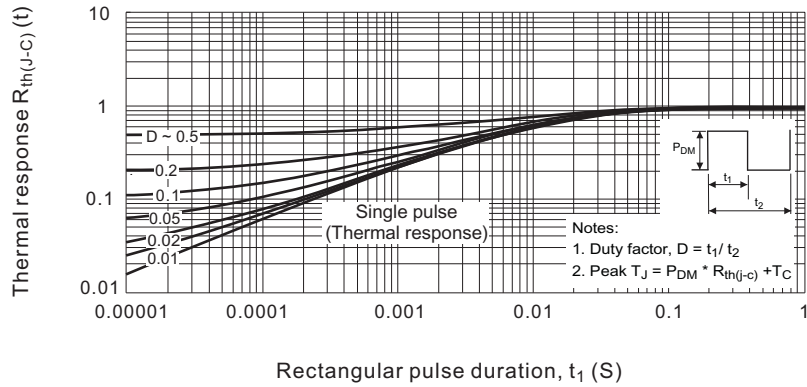
**Fig.8 Maximum safe operating area**



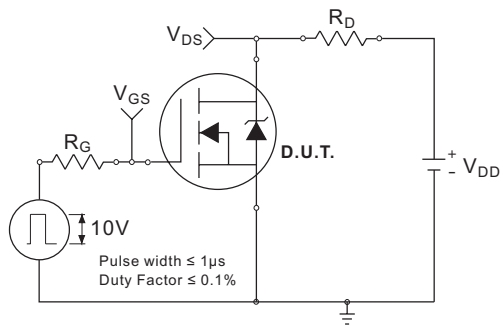
**Fig.9 Maximum drain current vs. Case temperature**



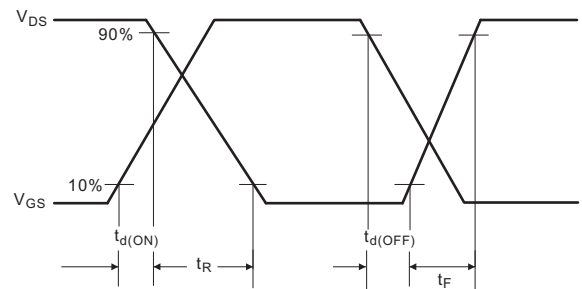
**Fig.10 Maximum effective transient thermal impedance, Junction-to-Case**



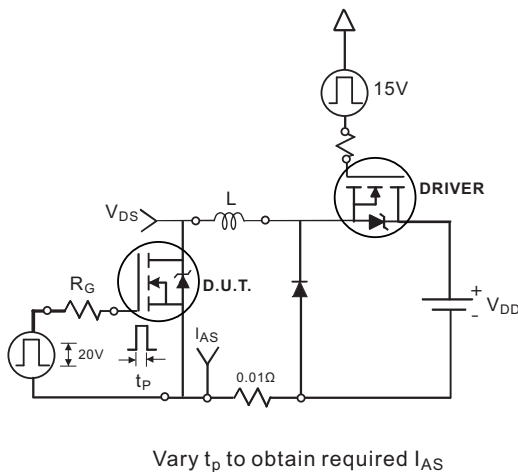
**Fig.11a. Switching time test circuit**



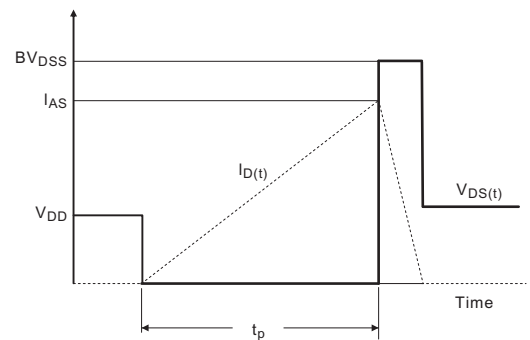
**Fig.11b. Switching time waveforms**



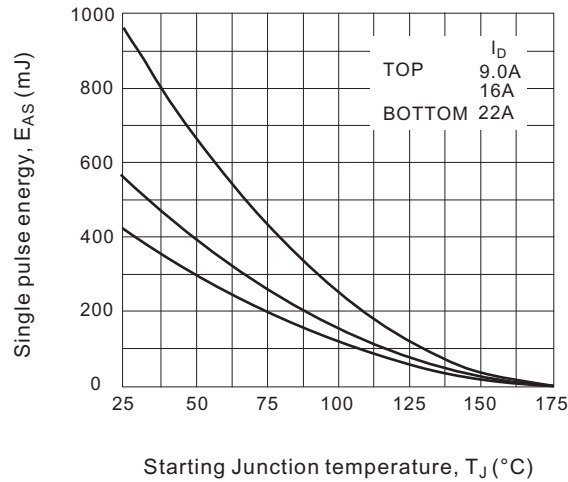
**Fig.12a. Unclamped Inductive test circuit**



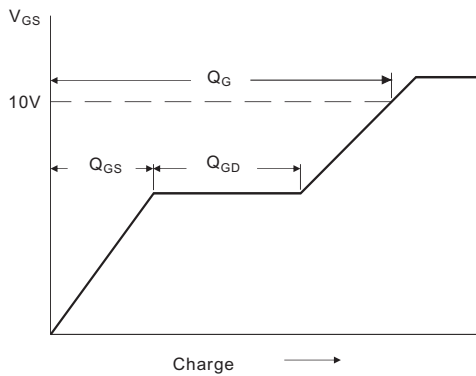
**Fig.12b. Unclamped Inductive waveforms**



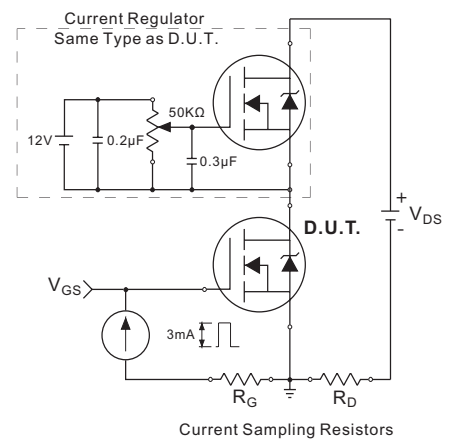
**Fig.12c. Maximum avalanche energy vs. Drain current**



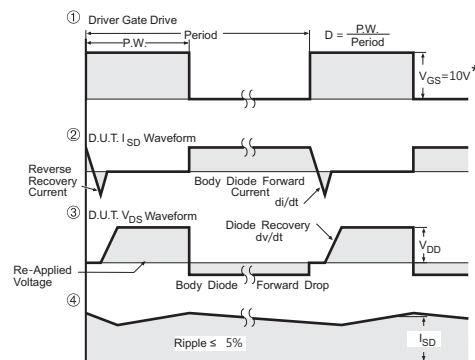
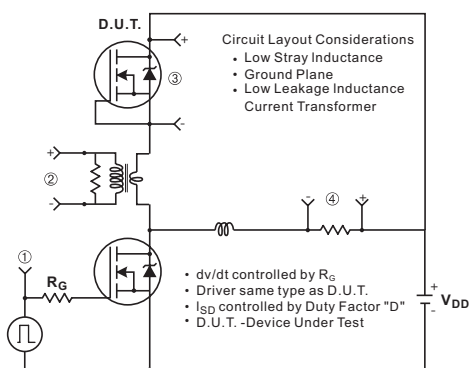
**Fig.13a. Basic gate charge waveform**



**Fig.13b. Gate charge test circuit**

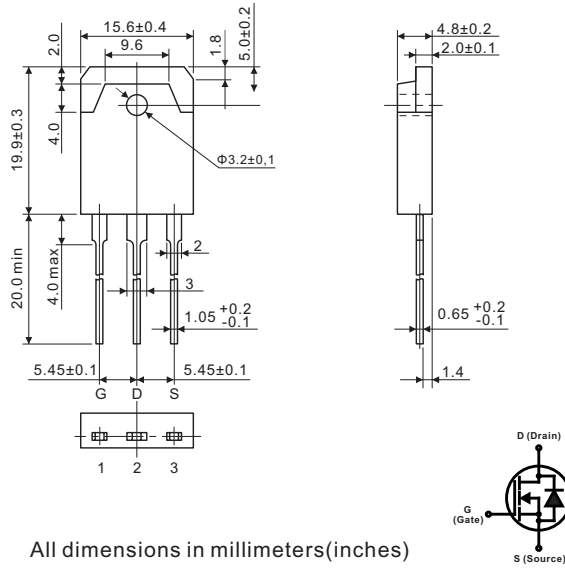


**Fig.14 Peak diode recovery dv/dt test circuit for N-Channel MOSFET**



\* $V_{GS} = 5V$  for Logic Level Devices and  $3V$  for drive devices

### TO-3PB



### TO-247AB

