

**HEXFET® Power MOSFET**

- Ultra Low Gate Charge
- Reduced Gate Drive Requirement
- Enhanced 30V  $V_{GS}$  Rating
- Isolated Package
- High Voltage Isolation= 2.5KV<sub>RMS</sub> Ⓢ
- Sink to Lead Creepage Dist.= 4.8mm
- Repetitive Avalanche Rated

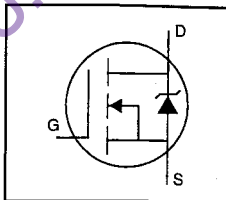

$$V_{DSS} = 500V$$

$$R_{DS(on)} = 0.85\Omega$$

$$I_D = 4.5A$$

**Description**

This new series of Low Charge HEXFETs achieve significantly lower gate charge over conventional MOSFETs. Utilizing advanced HEXFET technology, the device improvements allow for reduced gate drive requirements, faster switching speeds and increased total system savings. These device improvements combined with the proven ruggedness and reliability that are characteristic of HEXFETs offer the designer a new standard in power transistors for switching applications.

The TO-220 Fullpak eliminates the need for additional insulating hardware. The moulding compound used provides a high isolation capability and low thermal resistance between the tab and external heatsink.

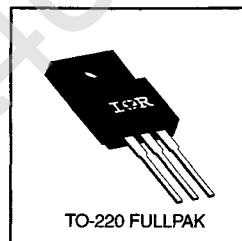
**Absolute Maximum Ratings**

|                           | Parameter  | Max.                  | Units |
|---------------------------|--|-----------------------|-------|
| $I_D @ T_C = 25^\circ C$  | Continuous Drain Current, $V_{GS} @ 10 V$        | 4.5                   | A     |
| $I_D @ T_C = 100^\circ C$ | Continuous Drain Current, $V_{GS} @ 10 V$        | 2.9                   | A     |
| $I_{DM}$                  | Pulsed Drain Current ①                           | 18                    | A     |
| $P_D @ T_C = 25^\circ C$  | Power Dissipation                                | 40                    | W     |
|                           | Linear Derating Factor                           | 0.32                  | W/°C  |
| $V_{GS}$                  | Gate-to-Source Voltage                           | $\pm 30$              | V     |
| $E_{AS}$                  | Single Pulse Avalanche Energy ②                  | 300                   | mJ    |
| $I_{AR}$                  | Avalanche Current ①                              | 4.5                   | A     |
| $E_{AR}$                  | Repetitive Avalanche Energy ①                    | 4.0                   | mJ    |
| $dv/dt$                   | Peak Diode Recovery $dv/dt$ ③                    | 3.5                   | V/ns  |
| $T_J$                     | Operating Junction and Storage Temperature Range | -55 to +150           | °C    |
|                           | Soldering Temperature, for 10 seconds            | 300 (1.6mm from case) |       |
|                           | Mounting Torque, 6-32 or M3 screw                | 10 lbf•in (1.1 N•m)   |       |

**Thermal Resistance**

|                 | Parameter           | Min. | Typ. | Max. | Units |
|-----------------|---------------------|------|------|------|-------|
| $R_{\theta JC}$ | Junction-to-Case    | —    | —    | 3.1  | °C/W  |
| $R_{\theta JA}$ | Junction-to-Ambient | —    | —    | 65   | °C/W  |

## Electrical Characteristics @ $T_J = 25^\circ\text{C}$ (unless otherwise specified)

|                                 | Parameter                            | Min. | Typ. | Max. | Units              | Test Conditions                                 |
|---------------------------------|--------------------------------------|------|------|------|--------------------|---|
| $V_{(BR)DSS}$                   | Drain-to-Source Breakdown Voltage    | 500  | —    | —    | V                  | $V_{GS}=0V, I_D=250\mu A$                       |
| $\Delta V_{(BR)DSS}/\Delta T_J$ | Breakdown Voltage Temp. Coefficient  | —    | 0.63 | —    | $V/^\circ\text{C}$ | Reference to $25^\circ\text{C}, I_D=1\text{mA}$ |
| $R_{DS(on)}$                    | Static Drain-to-Source On-Resistance | —    | —    | 0.85 | $\Omega$           | $V_{GS}=10V, I_D=2.7A$ ④                        |
| $V_{GS(th)}$                    | Gate Threshold Voltage               | 2.0  | —    | 4.0  | V                  | $V_{DS}=V_{GS}, I_D=250\mu A$                   |
| $g_{fs}$                        | Forward Transconductance             | 4.0  | —    | —    | S                  | $V_{DS}=50V, I_D=4.8A$ ④                        |
| $I_{DSS}$                       | Drain-to-Source Leakage Current      | —    | —    | 25   | $\mu A$            | $V_{DS}=500V, V_{GS}=0V$                        |
|                                 |                                      | —    | —    | 250  |                    | $V_{DS}=400V, V_{GS}=0V, T_J=125^\circ\text{C}$ |
| $I_{GSS}$                       | Gate-to-Source Forward Leakage       | —    | —    | 100  | nA                 | $V_{GS}=20V$                                    |
|                                 | Gate-to-Source Reverse Leakage       | —    | —    | -100 |                    | $V_{GS}=-20V$                                   |
| $Q_g$                           | Total Gate Charge                    | —    | —    | 39   | nC                 | $I_D=8.0A$                                      |
| $Q_{gs}$                        | Gate-to-Source Charge                | —    | —    | 10   |                    | $V_{DS}=400V$                                   |
| $Q_{gd}$                        | Gate-to-Drain ("Miller") Charge      | —    | —    | 19   |                    | $V_{GS}=10V$ See Fig. 6 and 13 ④                |
| $t_{d(on)}$                     | Turn-On Delay Time                   | —    | 12   | —    | ns                 | $V_{DD}=250V$                                   |
| $t_r$                           | Rise Time                            | —    | 25   | —    |                    | $I_D=8.0A$                                      |
| $t_{d(off)}$                    | Turn-Off Delay Time                  | —    | 27   | —    |                    | $R_G=9.1\Omega$                                 |
| $t_f$                           | Fall Time                            | —    | 19   | —    |                    | $R_D=30\Omega$ See Figure 10 ④                  |
| $L_D$                           | Internal Drain Inductance            | —    | 4.5  | —    |                    | nH  |
| $L_S$                           | Internal Source Inductance           | —    | 7.5  | —    |                    |   |
| $C_{iss}$                       | Input Capacitance                    | —    | 1100 | —    | pF                 | $V_{GS}=0V$                                     |
| $C_{oss}$                       | Output Capacitance                   | —    | 170  | —    |                    | $V_{DS}=25V$                                    |
| $C_{rss}$                       | Reverse Transfer Capacitance         | —    | 18   | —    |                    | $f=1.0\text{MHz}$ See Figure 5                  |
| C                               | Drain to Sink Capacitance            | —    | 12   | —    |                    | $f=1.0\text{MHz}$                               |

## Source-Drain Ratings and Characteristics

|          | Parameter                              | Min.  | Typ. | Max. | Units   | Test Conditions  |
|----------|--|---|------|------|---------|--|
| $I_S$    | Continuous Source Current (Body Diode) | —   | —    | 4.5  | A       | MOSFET symbol showing the integral reverse p-n junction diode. |
| $I_{SM}$ | Pulsed Source Current (Body Diode) ①   | —   | —    | 18   |         |  |
| $V_{SD}$ | Diode Forward Voltage                  | —   | —    | 2.0  | V       | $T_J=25^\circ\text{C}, I_S=4.5A, V_{GS}=0V$ ④                  |
| $t_{rr}$ | Reverse Recovery Time                  | —   | 490  | 740  | ns      | $T_J=25^\circ\text{C}, I_F=8.0A$                               |
| $Q_{rr}$ | Reverse Recovery Charge                | —   | 3.0  | 4.5  | $\mu C$ | $di/dt=100A/\mu s$ ④   |
| $t_{on}$ | Forward Turn-On Time                   | Intrinsic turn-on time is negligible (turn-on is dominated by $L_S+L_D$ ) |      |      |         |  |

### Notes:

- ① Repetitive rating; pulse width limited by max. junction temperature (See Figure 11)
- ②  $V_{DD}=50V$ , starting  $T_J=25^\circ\text{C}$ ,  $L=26\text{mH}$ ,  $R_G=25\Omega$ ,  $I_{AS}=4.5A$  (See Figure 12)
- ③  $I_{SD}\leq 8.0A$ ,  $di/dt\leq 100A/\mu s$ ,  $V_{DD}\leq V_{(BR)DSS}$ ,  $T_J\leq 150^\circ\text{C}$
- ④ Pulse width  $\leq 300\mu s$ ; duty cycle  $\leq 2\%$
- ⑤  $t=60s$ ,  $f=60\text{Hz}$

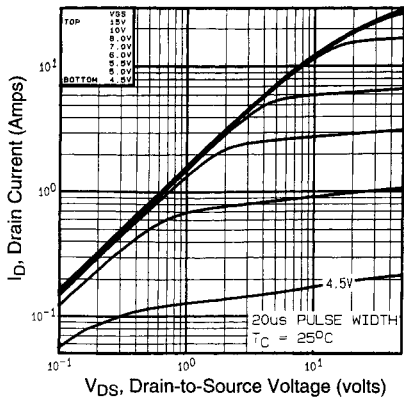

**Fig 1.** Typical Output Characteristics,  
 $T_C=25^\circ\text{C}$

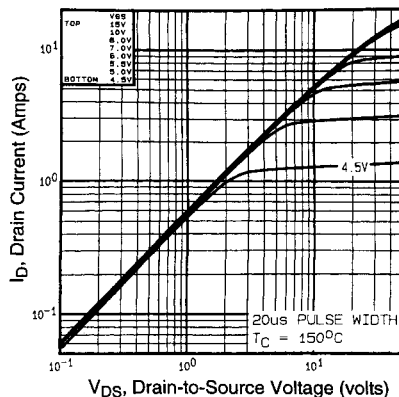

**Fig 2.** Typical Output Characteristics,  
 $T_C=150^\circ\text{C}$

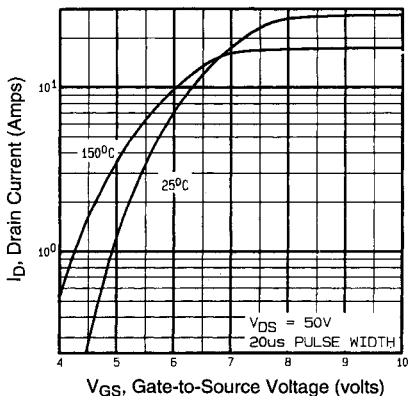

**Fig 3.** Typical Transfer Characteristics

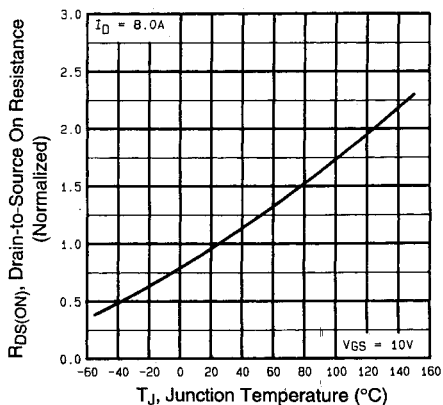

**Fig 4.** Normalized On-Resistance  
Vs. Temperature

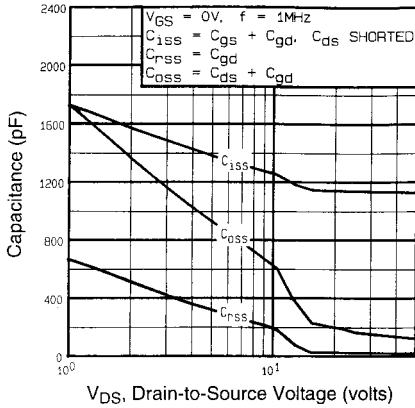

**Fig 5.** Typical Capacitance Vs. Drain-to-Source Voltage

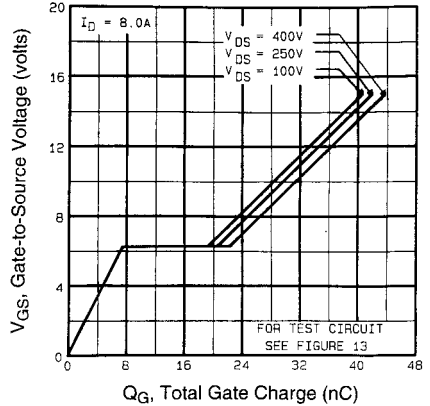

**Fig 6.** Typical Gate Charge Vs. Gate-to-Source Voltage

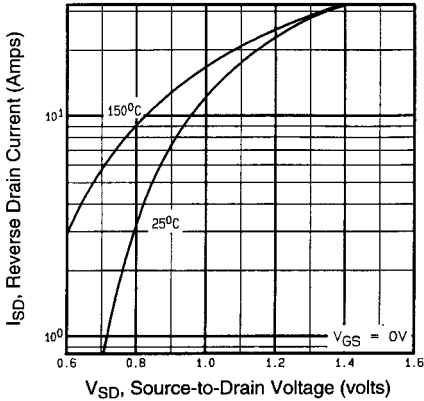

**Fig 7.** Typical Source-Drain Diode Forward Voltage

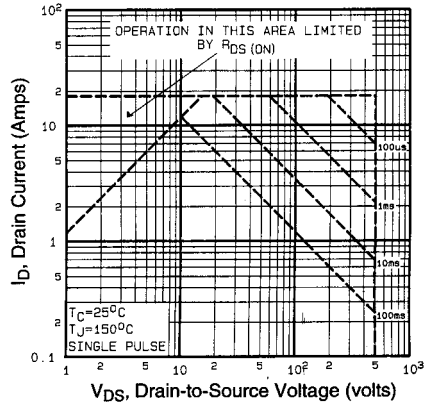

**Fig 8.** Maximum Safe Operating Area

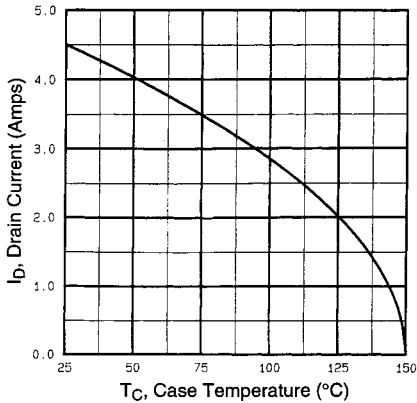

**Fig 9.** Maximum Drain Current Vs. Case Temperature

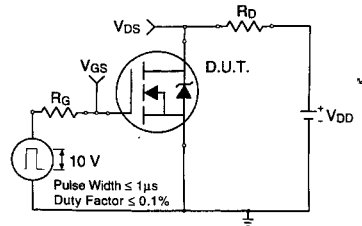

**Fig 10a.** Switching Time Test Circuit

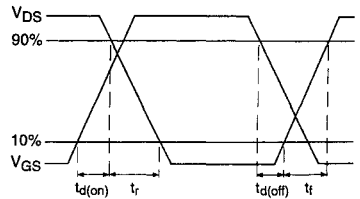

**Fig 10b.** Switching Time Waveforms

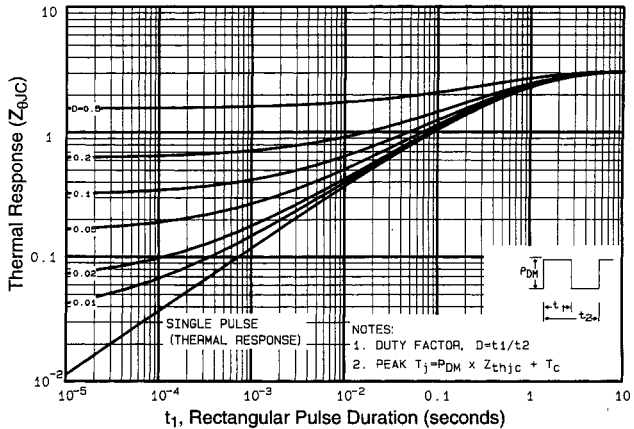

**Fig 11.** Maximum Effective Transient Thermal Impedance, Junction-to-Case

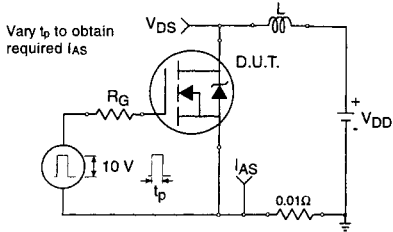

**Fig 12a.** Unclamped Inductive Test Circuit

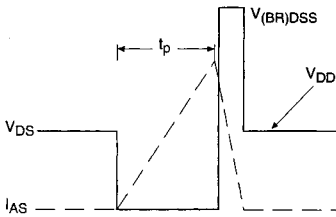

**Fig 12b.** Unclamped Inductive Waveforms

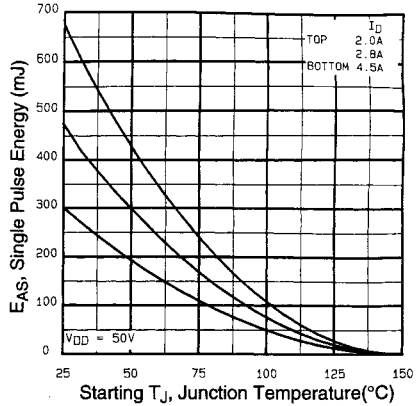

**Fig 12c.** Maximum Avalanche Energy Vs. Drain Current

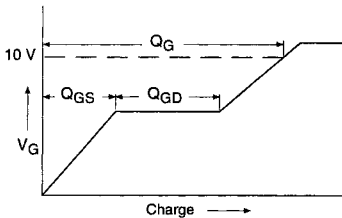

**Fig 13a.** Basic Gate Charge Waveform

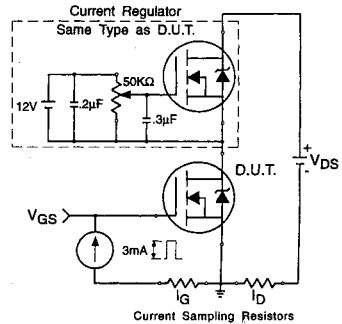
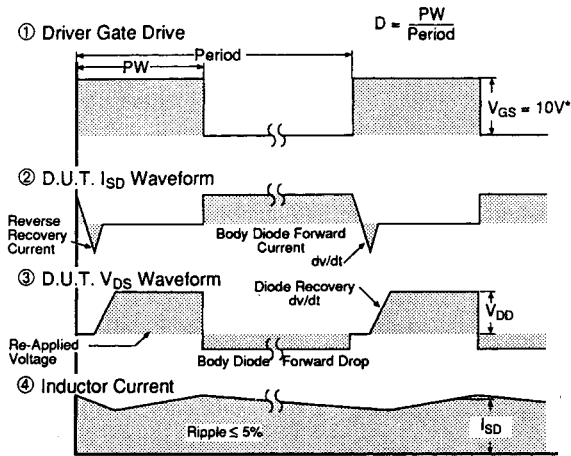
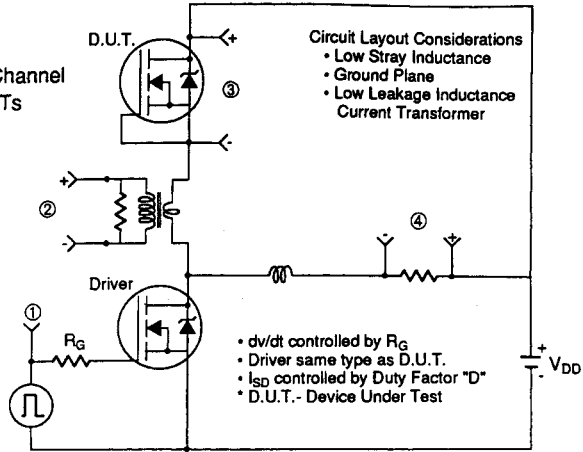

**Fig 13b.** Gate Charge Test Circuit

# Appendix A

## Peak Diode Recovery $dv/dt$ Test Circuit

Fig 14. For N-Channel HEXFETs



\*  $V_{GS} = 5V$  for Logic Level Devices

## Package Outline

## Appendix B

### TO-220 FullPak Outline

Dimensions are shown in millimeters (inches)

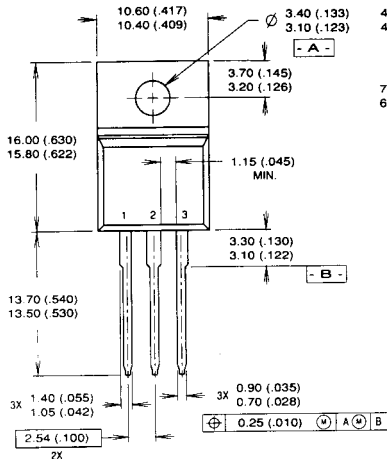

## Part Marking Information

## Appendix C

### TO-220 FULL-PAK

EXAMPLE: THIS IS AN IRFI840G WITH  
ASSEMBLY LOT CODE E401

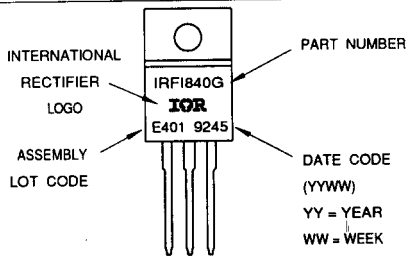

Printed on Signet recycled offset:  
made from 50% recycled waste paper, including  
10% de-inked, post-consumer waste.



**International**  
**IRI Rectifier**

WORLD HEADQUARTERS: 233 Kansas St., El Segundo, California 90245, Tel: (310) 322-3331, Twx: 4720403  
EUROPEAN HEADQUARTERS: Hurst Green, Oxted, Surrey RH8 9BB England, Tel: (0883) 713215, Twx: 95219

IR CANADA: 101 Bentley St., Markham, Ontario L3R 3L1, Tel: (416) 475-1897; IR GERMANY: Saalburgstrasse 157, D-6300 Bad Homburg, Tel: 6172-37066; IR ITALY: Via Liguria 49, 10071 Borgaro, Torino, Tel: (011) 470 1484; IR FAIR EAST: K&H Building, 35-4 Nishikotokuro 3-Chome, Toshima-Ku, Tokyo 171 Japan, Tel: (03) 963 0641; IR SOUTHEAST ASIA: 190 Middle Road, HEX 10-01 Fortune Centre, Singapore 0718, Tel: (65) 338 3922.

Sales Offices, Agents and Distributors in Major Cities Throughout the World.