

IRF634

N-channel mosfet transistor



1 2 3

◆ Features

- With TO-220 package
- Simple drive requirements
- Fast switching
- $V_{DSS}=250V$; $R_{DS(ON)} = 0.45 \Omega$; $I_D=8.1A$
- 1.gate 2.drain 3.source

◆ Absolute Maximum Ratings $T_c=25$

SYMBOL	PARAMETER	RATING	UNIT
V_{DSS}	Drain-source voltage ($V_{GS}=0$)	250	V
V_{GS}	Gate-source voltage	± 20	V
I_D	Drain Current-continuous@ $T_c=25$	8.1	A
P_{tot}	Total Dissipation@ $T_c=25$	74	W
T_j	Max. Operating Junction temperature	150	
T_{stg}	Storage temperature	-65~150	

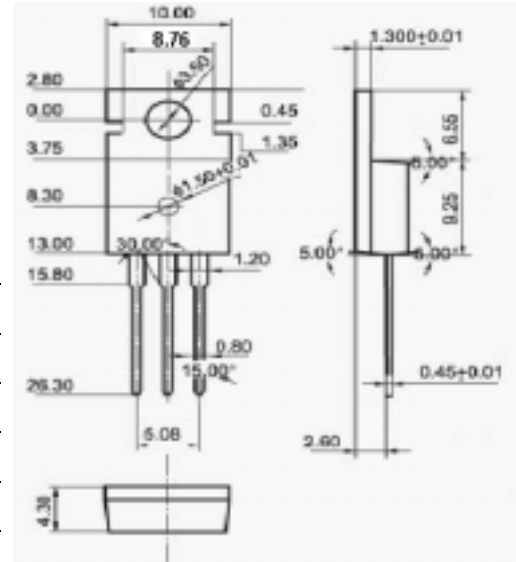

TO-220

◆ Electrical Characteristics $T_c=25$

SYMBOL	PARAMETER	CONDITIONS	MIN	MAX	UNIT
$V_{(BR)DSS}$	Drain-source breakdown voltage	$V_{GS}=0$; $I_D=0.25mA$	250		V
$V_{GS(TH)}$	Gate threshold voltage	$V_{DS}=V_{GS}$; $I_D=0.25mA$	2	4	V
$R_{DS(ON)}$	Drain-source on-stage resistance	$V_{GS}=10V$; $I_D=5.1A$		450	m
I_{GSS}	Gate source leakage current	$V_{GS}=\pm 20V$; $V_{DS}=0$		± 100	nA
I_{DSS}	Zero gate voltage drain current	$V_{DS}=250V$; $V_{GS}=0$		25	μA
V_{SD}	Diode forward voltage	$I_F=8.1A$; $V_{GS}=0$		2.0	V