



# POWER-MOS FET

## FIELD EFFECT POWER TRANSISTOR

### IRF712,713

1.3 AMPERES  
400, 350 VOLTS  
RDS(ON) = 5 Ω

This series of N-Channel Enhancement-mode Power MOSFETs utilizes GE's advanced Power DMOS technology to achieve low on-resistance with excellent device ruggedness and reliability.

This design has been optimized to give superior performance in most switching applications including: switching power supplies, inverters, converters and solenoid/relay drivers. Also, the extended safe operating area with good linear transfer characteristics makes it well suited for many linear applications such as audio amplifiers and servo motors.

### Features

- Polysilicon gate — Improved stability and reliability
- No secondary breakdown — Excellent ruggedness
- Ultra-fast switching — Independent of temperature
- Voltage controlled — High transconductance
- Low input capacitance — Reduced drive requirement
- Excellent thermal stability — Ease of paralleling

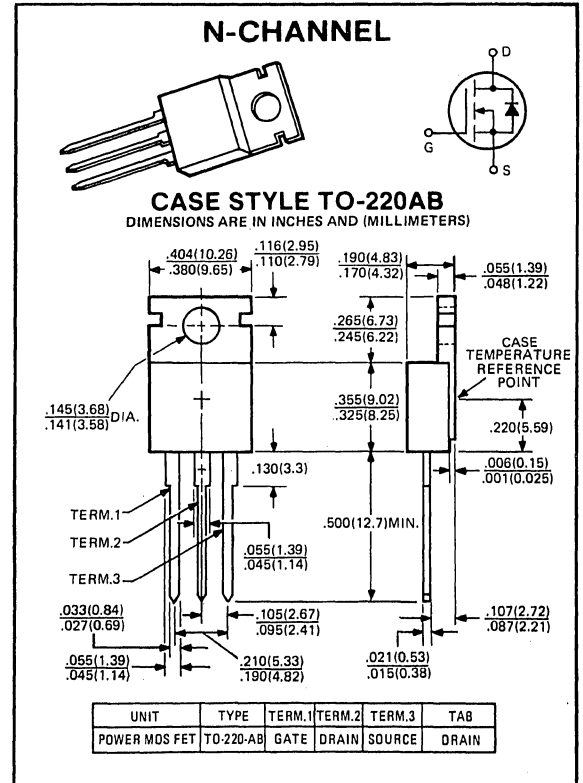

maximum ratings ( $T_C = 25^\circ\text{C}$ ) (unless otherwise specified)

RATING	SYMBOL	IRF712	IRF713	UNITS
Drain-Source Voltage	$V_{DSS}$	400	350	Volts
Drain-Gate Voltage, $R_{GS} = 1M\Omega$	$V_{DGR}$	400	350	Volts
Continuous Drain Current @ $T_C = 25^\circ\text{C}$ @ $T_C = 100^\circ\text{C}$	$I_D$	1.3 0.8	1.3 0.8	A
Pulsed Drain Current <sup>(1)</sup>	$I_{DM}$	5.0	5.0	A
Gate-Source Voltage	$V_{GS}$	$\pm 20$	$\pm 20$	Volts
Total Power Dissipation @ $T_C = 25^\circ\text{C}$ Derate Above $25^\circ\text{C}$	$P_D$	20 0.16	20 0.16	Watts W/ $^\circ\text{C}$
Operating and Storage Junction Temperature Range	$T_J, T_{STG}$	-55 to 150	-55 to 150	$^\circ\text{C}$

### thermal characteristics

Thermal Resistance, Junction to Case	$R_{\theta JC}$	6.4	6.4	$^\circ\text{C/W}$
Thermal Resistance, Junction to Ambient	$R_{\theta JA}$	80	80	$^\circ\text{C/W}$
Maximum Lead Temperature for Soldering Purposes: 1/8" from Case for 5 Seconds	$T_L$	260	260	$^\circ\text{C}$

(1) Repetitive Rating: Pulse width limited by max. junction temperature.

electrical characteristics ( $T_C = 25^\circ\text{C}$ ) (unless otherwise specified)

CHARACTERISTIC	SYMBOL	MIN	TYP	MAX	UNIT
----------------	--------	-----	-----	-----	------

off characteristics

Drain-Source Breakdown Voltage ( $V_{GS} = 0V, I_D = 250 \mu A$ )	IRF712 IRF713	BV <sub>DSS</sub>	400 350	— —	— —	Volts
Zero Gate Voltage Drain Current ( $V_{DS} = \text{Max Rating}, V_{GS} = 0V, T_C = 25^\circ\text{C}$ ) ( $V_{DS} = \text{Max Rating}, \times 0.8, V_{GS} = 0V, T_C = 125^\circ\text{C}$ )		I <sub>DSS</sub>	— —	— —	250 1000	$\mu A$
Gate-Source Leakage Current ( $V_{GS} = \pm 20V$ )		I <sub>GSS</sub>	—	—	$\pm 500$	nA

on characteristics\*

Gate Threshold Voltage ( $V_{DS} = V_{GS}, I_D = 250 \mu A$ )	$T_C = 25^\circ\text{C}$	V <sub>GS(TH)</sub>	2.0	—	4.0	Volts
On-State Drain Current ( $V_{GS} = 10V, V_{DS} = 10V$ )		I <sub>D(ON)</sub>	1.3	—	—	A
Static Drain-Source On-State Resistance ( $V_{GS} = 10V, I_D = 0.8A$ )		R <sub>DS(ON)</sub>	—	—	5.0	Ohms
Forward Transconductance ( $V_{DS} = 10V, I_D = 0.8A$ )		g <sub>fs</sub>	.45	—	—	mhos

dynamic characteristics

Input Capacitance	V <sub>GS</sub> = 0V	C <sub>iss</sub>	—	—	150	pF
Output Capacitance	V <sub>DS</sub> = 25V	C <sub>oss</sub>	—	—	50	pF
Reverse Transfer Capacitance	f = 1 MHz	C <sub>rss</sub>	—	—	15	pF

switching characteristics\*

Turn-on Delay Time	V <sub>DS</sub> = 175V	t <sub>d(on)</sub>	—	10	—	ns
Rise Time	I <sub>D</sub> = 0.8A, V <sub>GS</sub> = 15V	t <sub>r</sub>	—	15	—	ns
Turn-off Delay Time	R <sub>GEN</sub> = 50 $\Omega$ , R <sub>GS</sub> = 12.5 $\Omega$	t <sub>d(off)</sub>	—	10	—	ns
Fall Time	(R <sub>GS</sub> (EQUIV.) = 10 $\Omega$ )	t <sub>f</sub>	—	10	—	ns

source-drain diode ratings and characteristics\*

Continuous Source Current	I <sub>S</sub>	—	—	1.3	A
Pulsed Source Current	I <sub>SM</sub>	—	—	5.0	A
Diode Forward Voltage ( $T_C = 25^\circ\text{C}, V_{GS} = 0V, I_S = 1.3A$ )	V <sub>SD</sub>	—	—	1.5	Volts
Reverse Recovery Time ( $I_S = 1.5A, di_S/dt = 100A/\mu\text{sec}, T_C = 125^\circ\text{C}$ )	t <sub>rr</sub> Q <sub>RR</sub>	—	200 1.5	—	ns $\mu C$

\*Pulse Test: Pulse width  $\leq 300 \mu s$ , duty cycle  $\leq 2\%$

