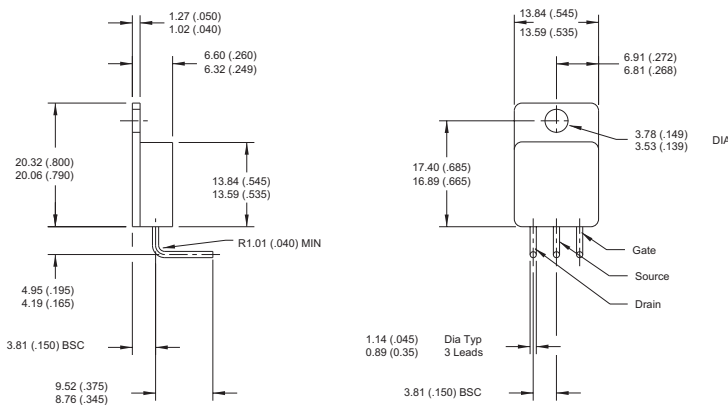

MECHANICAL DATA

Dimensions in mm (inches)

**N-CHANNEL
POWER MOSFET**
 V_{DSS} **200V**
 $I_{D(cont)}$ **27.4A**
 $R_{DS(on)}$ **0.100Ω**
FEATURES

- N-CHANNEL MOSFET
- HIGH VOLTAGE
- INTEGRAL PROTECTION DIODE
- HERMETIC ISOLATED TO-254 PACKAGE
- CERAMIC SURFACE MOUNT PACKAGE OPTION

TO-254 Metal Package

Pin 1 – Drain Pin 2 – Source Pin 3 – Gate

ABSOLUTE MAXIMUM RATINGS ($T_C = 25^\circ\text{C}$ unless otherwise stated)

V_{GS}	Gate – Source Voltage		$\pm 20\text{V}$
I_D	Continuous Drain Current	@ $V_{GS} = 10\text{V}$, $T_C = 25^\circ\text{C}$	27.4A
		@ $V_{GS} = 10\text{V}$, $T_C = 100^\circ\text{C}$	17A
I_{DM}	Pulsed Drain Current		110A
P_D	Max. Power Dissipation	@ $T_C = 25^\circ\text{C}$	150W
	Linear Derating Factor		1.2W / °C
I_L	Avalanche Current, Clamped ¹		27.4A
dv / dt	Peak Diode Recovery ²		5.5V / ns
$R_{\theta JC}$	Thermal Resistance Junction – Case		0.83°C / W
$R_{\theta JA}$	Thermal Resistance Junction – Ambient		48°C / W
$R_{\theta CS}$	Thermal Resistance Case – Sink		0.21°C / W typ.
T_J, T_{STG}	Operating Junction and Storage Temperature Range		-55 to 150°C
T_L	Lead Temperature (1.6mm from case for 10s)		300°C

 1) $V_{DD} = 50\text{V}$, Starting $T_J = 25^\circ\text{C}$, $L \geq 1\text{mH}$, $R_G = 25\Omega$, Peak $I_L = 27.4\text{A}$

 2) $I_{SD} \leq 27.4\text{A}$, $di/dt \leq 190\text{A} / \mu\text{S}$, $V_{DD} \leq BV_{DSS}$, $T_J \leq 150^\circ\text{C}$, Suggested $R_G = 2.35\Omega$

ELECTRICAL CHARACTERISTICS ($T_J = 25^\circ\text{C}$ unless otherwise stated)

Parameter	Test Conditions	Min.	Typ.	Max.	Unit	
STATIC ELECTRICAL RATINGS						
BV_{DSS}	Drain – Source Breakdown Voltage	$V_{GS} = 0$	$I_D = 1\text{mA}$	200	V	
$\frac{\Delta BV_{DSS}}{\Delta T_J}$	Temperature Coefficient of Breakdown Voltage	Reference to 25°C $I_D = 1\text{mA}$		0.28	$\text{V}/^\circ\text{C}$	
$R_{DS(on)}$	Static Drain – Source On–State Resistance ²	$V_{GS} = 10\text{V}$	$I_D = 17\text{A}$		0.100	
		$V_{GS} = 10\text{V}$	$I_D = 27.4\text{A}$		0.105	
$V_{GS(th)}$	Gate Threshold Voltage	$V_{DS} = V_{GS}$	$I_D = 250\mu\text{A}$	2	4	V
g_{fs}	Forward Transconductance ²	$V_{DS} \geq 15\text{V}$	$I_{DS} = 27.4\text{A}$	9		$\text{S}(\overline{\tau})$
I_{DSS}	Zero Gate Voltage Drain Current	$V_{GS} = 0$	$V_{DS} = 0.8BV_{DSS}$		25	μA
			$T_J = 125^\circ\text{C}$			250
I_{GSS}	Forward Gate – Source Leakage	$V_{GS} = 20\text{V}$			100	nA
I_{GSS}	Reverse Gate – Source Leakage	$V_{GS} = -20\text{V}$			-100	
DYNAMIC CHARACTERISTICS						
C_{iss}	Input Capacitance	$V_{GS} = 0$ $V_{DS} = 25\text{V}$ $f = 1\text{MHz}$		3500		pF
C_{oss}	Output Capacitance			700		
C_{rss}	Reverse Transfer Capacitance			110		
C_{DC}	Drain – Case Capacitance			12		
Q_g	Total Gate Charge	$V_{GS} = 10\text{V}$		55	115	nC
Q_{gs}	Gate – Source Charge	$I_D = 27.4\text{A}$		8	22	
Q_{gd}	Gate – Drain (“Miller”) Charge	$V_{DS} = 0.5BV_{DSS}$		30	60	
$t_{d(on)}$	Turn– On Delay Time	$V_{DD} = 100\text{V}$ $I_D = 27.4\text{A}$ $R_G = 2.35\Omega$			35	ns
t_r	Rise Time				190	
$t_{d(off)}$	Turn–Off Delay Time				170	
t_f	Fall Time				130	
SOURCE – DRAIN DIODE CHARACTERISTICS						
I_S	Continuous Source Current				27.4	A
I_{SM}	Pulse Source Current ¹				110	
V_{SD}	Diode Forward Voltage ²	$I_S = 27.4\text{A}$	$T_J = 25^\circ\text{C}$		1.9	V
t_{rr}	Reverse Recovery Time ²	$I_F = 27.4\text{A}$	$T_J = 25^\circ\text{C}$		950	ns
Q_{rr}	Reverse Recovery Charge ²	$d_i / d_t \leq 100\text{A}/\mu\text{s}$		$V_{DD} \leq 50\text{V}$	9.0	μC
t_{on}	Forward Turn–On Time	Negligible				
PACKAGE CHARACTERISTICS						
L_D	Internal Drain Inductance	Measured from 6mm down drain lead to centre of die			8.7	nH
L_S	Internal Source Inductance	Measured from 6mm down source lead to source bond pad			8.7	

Notes

- 1) Repetitive Rating – Pulse width limited by Maximum Junction Temperature
- 2) Pulse Test: Pulse Width $\leq 300\mu\text{s}$, $\delta \leq 2\%$.