

isc N-Channel MOSFET Transistor

IRFP150FI

FEATURES

- Drain Current  $-I_D = 23A @ T_C = 25^\circ C$
- Drain Source Voltage-  
:  $V_{DSS} = 100V(\text{Min})$
- Static Drain-Source On-Resistance  
:  $R_{DS(on)} = 0.055 \Omega (\text{Max})$
- Fast Switching

DESCRIPTION

- Designed for use in switch mode power supplies and general purpose applications.

ABSOLUTE MAXIMUM RATINGS( $T_a = 25^\circ C$ )

SYMBOL	PARAMETER	VALUE	UNIT
$V_{DSS}$	Drain-Source Voltage	100	V
$V_{GS}$	Gate-Source Voltage-Continuous	$\pm 20$	V
$I_D$	Drain Current-Continuous	23	A
$I_{DM}$	Drain Current-Single Pulse	92	A
$P_D$	Total Dissipation @ $T_C = 25^\circ C$	60	W
$T_J$	Max. Operating Junction Temperature	-55~150	$^\circ C$
$T_{stg}$	Storage Temperature	-55~150	$^\circ C$

THERMAL CHARACTERISTICS

SYMBOL	PARAMETER	MAX	UNIT
$R_{th j-c}$	Thermal Resistance, Junction to Case	0.7	$^\circ C/W$
$R_{th j-a}$	Thermal Resistance, Junction to Ambient	30	$^\circ C/W$

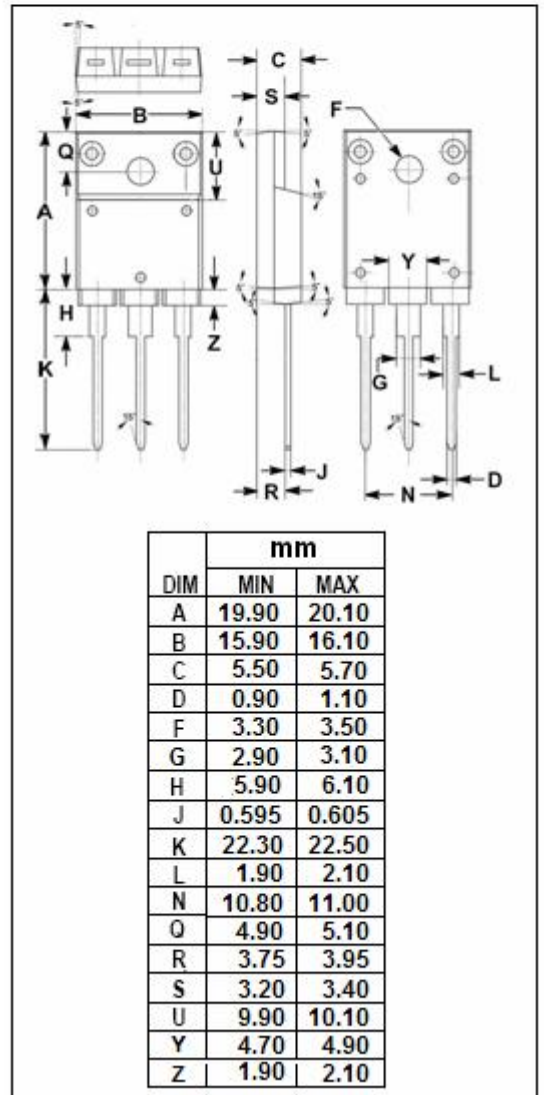
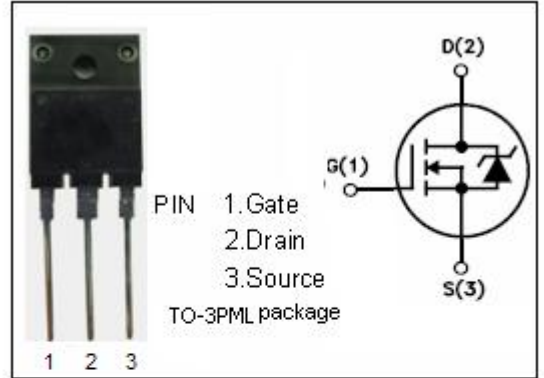

**isc N-Channel MOSFET Transistor****IRFP150FI****ELECTRICAL CHARACTERISTICS** $T_C=25^{\circ}\text{C}$  unless otherwise specified

SYMBOL	PARAMETER	CONDITIONS	MIN	MAX	UNIT
$V_{(BR)DSS}$	Drain-Source Breakdown Voltage	$V_{GS}=0; I_D=0.25\text{mA}$	100		V
$V_{GS(th)}$	Gate Threshold Voltage	$V_{DS}=V_{GS}; I_D=0.25\text{mA}$	2	4	V
$R_{DS(on)}$	Drain-Source On-Resistance	$V_{GS}=10\text{V}; I_D=22\text{A}$		0.055	$\Omega$
$I_{GSS}$	Gate-Body Leakage Current	$V_{GS}=\pm 20\text{V}; V_{DS}=0$		$\pm 100$	nA
$I_{DSS}$	Zero Gate Voltage Drain Current	$V_{DS}=100\text{V}; V_{GS}=0$		250	$\mu\text{A}$
$V_{SD}$	Forward On-Voltage	$I_S=23\text{A}; V_{GS}=0$		2.5	V