

isc N-Channel MOSFET Transistor

IRFP350FI

FEATURES

- Drain Current $-I_D = 10A @ T_C = 25^\circ C$
- Drain Source Voltage-
: $V_{DSS} = 400V(\text{Min})$
- Static Drain-Source On-Resistance
: $R_{DS(on)} = 0.3 \Omega (\text{Max})$
- Fast Switching

DESCRIPTION

- Designed for use in switch mode power supplies and general purpose applications.

ABSOLUTE MAXIMUM RATINGS($T_a = 25^\circ C$)

SYMBOL	PARAMETER	VALUE	UNIT
V_{DSS}	Drain-Source Voltage	400	V
V_{GS}	Gate-Source Voltage-Continuous	± 20	V
I_D	Drain Current-Continuous	10	A
I_{DM}	Drain Current-Single Pluse	40	A
P_D	Total Dissipation @ $T_C = 25^\circ C$	70	W
T_J	Max. Operating Junction Temperature	-55~150	$^\circ C$
T_{stg}	Storage Temperature	-55~150	$^\circ C$

THERMAL CHARACTERISTICS

SYMBOL	PARAMETER	MAX	UNIT
$R_{th j-c}$	Thermal Resistance, Junction to Case	0.83	$^\circ C/W$
$R_{th j-a}$	Thermal Resistance, Junction to Ambient	80	$^\circ C/W$

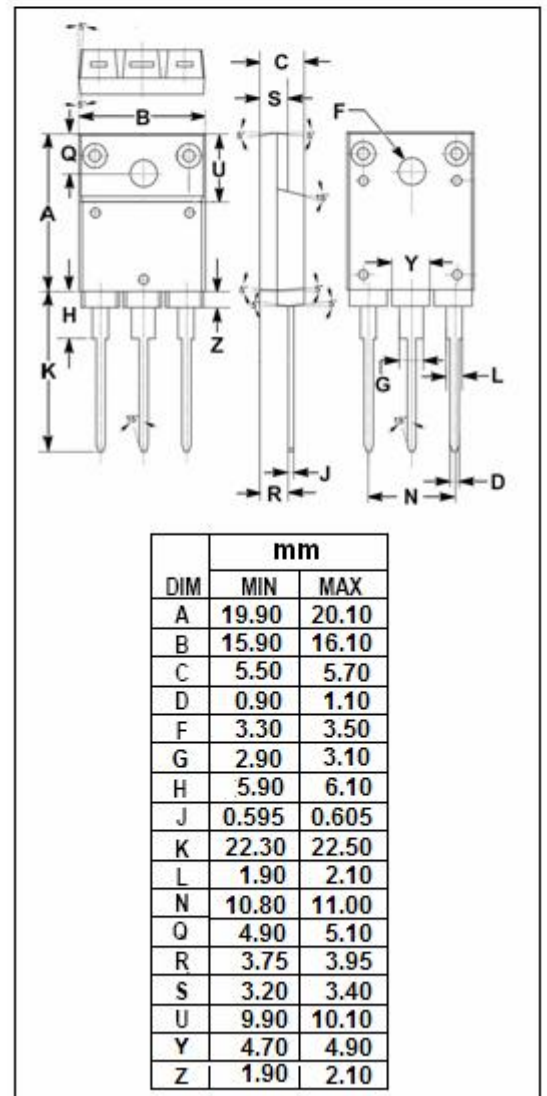
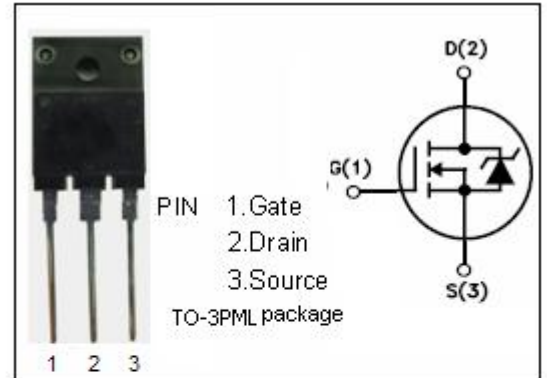

isc N-Channel MOSFET Transistor**IRFP350FI****ELECTRICAL CHARACTERISTICS** $T_C=25^{\circ}\text{C}$ unless otherwise specified

SYMBOL	PARAMETER	CONDITIONS	MIN	MAX	UNIT
$V_{(BR)DSS}$	Drain-Source Breakdown Voltage	$V_{GS}=0; I_D=0.25\text{mA}$	400		V
$V_{GS(th)}$	Gate Threshold Voltage	$V_{DS}=V_{GS}; I_D=0.25\text{mA}$	2	4	V
$R_{DS(on)}$	Drain-Source On-Resistance	$V_{GS}=10\text{V}; I_D=8\text{A}$		0.3	Ω
I_{GSS}	Gate-Body Leakage Current	$V_{GS}=\pm 20\text{V}; V_{DS}=0$		± 100	nA
I_{DSS}	Zero Gate Voltage Drain Current	$V_{DS}=400\text{V}; V_{GS}=0$ $V_{DS}=320\text{V}; V_{GS}=0; T_j=150^{\circ}\text{C}$		250 1000	μA
V_{SD}	Forward On-Voltage	$I_S=10\text{A}; V_{GS}=0$		1.6	V