



# POWER-MOS FET

## FIELD EFFECT POWER TRANSISTOR

### IRFP352,353

13 AMPERES  
400, 350 VOLTS  
R<sub>DS(ON)</sub> = 0.4 Ω

This series of N-Channel Enhancement-mode Power MOSFETs utilizes GE's advanced Power DMOS technology to achieve low on-resistance with excellent device ruggedness and reliability.

This design has been optimized to give superior performance in most switching applications including: switching power supplies, inverters, converters and solenoid/relay drivers. Also, the extended safe operating area with good linear transfer characteristics makes it well suited for many linear applications such as audio amplifiers and servo motors.

### Features

- Polysilicon gate — Improved stability and reliability
- No secondary breakdown — Excellent ruggedness
- Ultra-fast switching — Independent of temperature
- Voltage controlled — High transconductance
- Low input capacitance — Reduced drive requirement
- Excellent thermal stability — Ease of paralleling

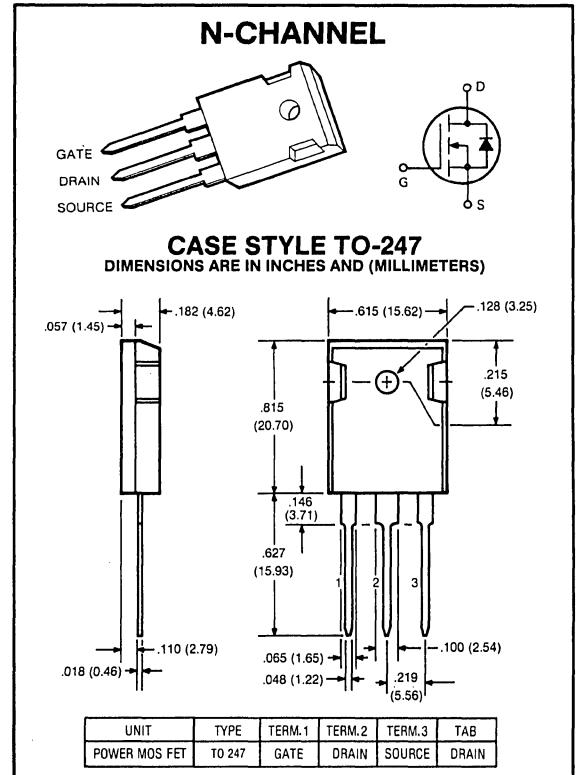

maximum ratings ( $T_C = 25^\circ\text{C}$ ) (unless otherwise specified)

RATING	SYMBOL	IRFP352	IRFP353	UNITS
Drain-Source Voltage	$V_{DSS}$	400	350	Volts
Drain-Gate Voltage, $R_{GS} = 1M\Omega$	$V_{DGR}$	400	350	Volts
Continuous Drain Current @ $T_C = 25^\circ\text{C}$ @ $T_C = 100^\circ\text{C}$	$I_D$	13 8	13 8	A A
Pulsed Drain Current <sup>(1)</sup>	$I_{DM}$	52	52	A
Gate-Source Voltage	$V_{GS}$	$\pm 20$	$\pm 20$	Volts
Total Power Dissipation @ $T_C = 25^\circ\text{C}$ Derate Above $25^\circ\text{C}$	$P_D$	150 1.2	150 1.2	Watts W/ $^\circ\text{C}$
Operating and Storage Junction Temperature Range	$T_J, T_{STG}$	-55 to 150	-55 to 150	$^\circ\text{C}$

### thermal characteristics

Thermal Resistance, Junction to Case	$R_{\theta JC}$	0.83	0.83	$^\circ\text{C/W}$
Thermal Resistance, Junction to Ambient	$R_{\theta JA}$	40	40	$^\circ\text{C/W}$
Maximum Lead Temperature for Soldering Purposes: $\frac{1}{8}$ " from Case for 5 Seconds	$T_L$	260	260	$^\circ\text{C}$

(1) Repetitive Rating: Pulse width limited by max. junction temperature.

electrical characteristics ( $T_C = 25^\circ\text{C}$ ) (unless otherwise specified)

CHARACTERISTIC	SYMBOL	MIN	TYP	MAX	UNIT
----------------	--------	-----	-----	-----	------

off characteristics

Drain-Source Breakdown Voltage ( $V_{GS} = 0V, I_D = 250\ \mu A$ )	IRFP352 IRFP353	$BV_{DSS}$	400 350	— —	— —	Volts
Zero Gate Voltage Drain Current ( $V_{DS} = \text{Max Rating}, V_{GS} = 0V, T_C = 25^\circ\text{C}$ ) ( $V_{DS} = \text{Max Rating}, \times 0.8, V_{GS} = 0V, T_C = 125^\circ\text{C}$ )		$I_{DSS}$	— —	— —	250 1000	$\mu A$
Gate-Source Leakage Current ( $V_{GS} = \pm 20V$ )		$I_{GSS}$	—	—	$\pm 500$	nA

on characteristics\*

Gate Threshold Voltage ( $V_{DS} = V_{GS}, I_D = 250\ \mu A$ )	$T_C = 25^\circ\text{C}$	$V_{GS(TH)}$	2.0	—	4.0	Volts
On-State Drain Current ( $V_{GS} = 10V, V_{DS} = 5.8V$ )		$I_{D(ON)}$	13	—	—	A
Static Drain-Source On-State Resistance ( $V_{GS} = 10V, I_D = 8A$ )		$R_{DS(ON)}$	—	0.35	0.40	Ohms
Forward Transconductance ( $V_{DS} = 5.3V, I_D = 8A$ )		$g_{fs}$	5.6	8.0	—	mhos

dynamic characteristics

Input Capacitance	$V_{GS} = 0V$	$C_{iss}$	—	2800	3000	pF
Output Capacitance	$V_{DS} = 25V$	$C_{oss}$	—	300	600	pF
Reverse Transfer Capacitance	$f = 1\ \text{MHz}$	$C_{rss}$	—	60	200	pF

switching characteristics\*

Turn-on Delay Time	$V_{DS} = 175V$	$t_{d(on)}$	—	20	—	ns
Rise Time	$I_D = 8A, V_{GS} = 15V$	$t_r$	—	25	—	ns
Turn-off Delay Time	$R_{GEN} = 50\ \Omega, R_{GS} = 12.5\ \Omega$	$t_{d(off)}$	—	110	—	ns
Fall Time	( $R_{GS}\ \text{(EQUIV.)} = 10\ \Omega$ )	$t_f$	—	70	—	ns

source-drain diode ratings and characteristics\*

Continuous Source Current	$I_S$	—	—	13	A
Pulsed Source Current	$I_{SM}$	—	—	52	A
Diode Forward Voltage ( $T_C = 25^\circ\text{C}, V_{GS} = 0V, I_S = 13A$ )	$V_{SD}$	—	0.9	1.5	Volts
Reverse Recovery Time ( $I_S = 15A, di_S/dt = 100A/\mu\text{sec}, T_C = 125^\circ\text{C}$ )	$t_{rr}$ $Q_{RR}$	—	500 6.5	—	ns $\mu C$

\*Pulse Test: Pulse width  $\leq 300\ \mu s$ , duty cycle  $\leq 2\%$

