

isc N-Channel MOSFET Transistor

IRFS240A

FEATURES

- Avalanche Rugged Technology
- Rugged Gate Oxide Technology
- Lower Input Capacitance
- Improved Gate Charge
- Extended Safe Operating Area

DESCRIPTION

- Designed for use in switch mode power supplies and general purpose applications.

ABSOLUTE MAXIMUM RATINGS(T_a=25°C)

SYMBOL	PARAMETER	VALUE	UNIT
V _{DSS}	Drain-Source Voltage	200	V
V _{GS}	Gate-Source Voltage-Continuous	±30	V
I _D	Drain Current-Continuous	12.8	A
I _{DM}	Drain Current-Single Pulse	80	A
P _D	Total Dissipation @T _C =25°C	73	W
T _J	Max. Operating Junction Temperature	-55~150	°C
T _{stg}	Storage Temperature	-55~150	°C

THERMAL CHARACTERISTICS

SYMBOL	PARAMETER	MAX	UNIT
R _{th j-c}	Thermal Resistance, Junction to Case	1.7	°C/W
R _{th j-a}	Thermal Resistance, Junction to Ambient	40	°C/W

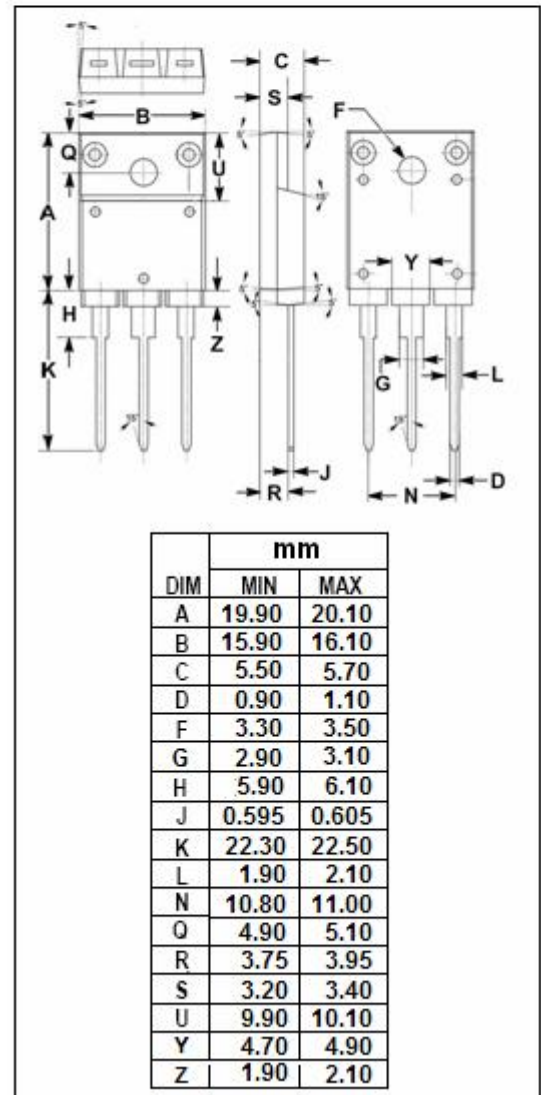
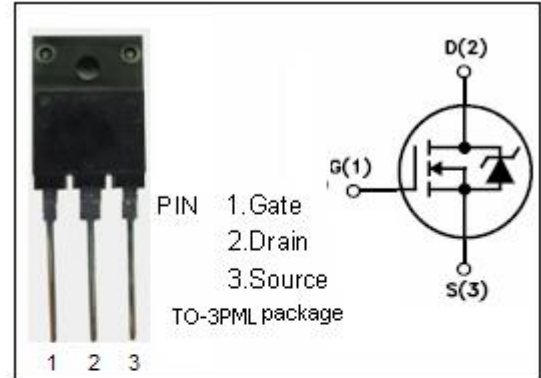

isc N-Channel MOSFET Transistor**IRFS240A****ELECTRICAL CHARACTERISTICS** $T_C=25^{\circ}\text{C}$ unless otherwise specified

SYMBOL	PARAMETER	CONDITIONS	MIN	MAX	UNIT
$V_{(BR)DSS}$	Drain-Source Breakdown Voltage	$V_{GS}=0; I_D=0.25\text{mA}$	200		V
$V_{GS(th)}$	Gate Threshold Voltage	$V_{DS}=V_{GS}; I_D=0.25\text{mA}$	2	4	V
$R_{DS(on)}$	Drain-Source On-Resistance	$V_{GS}=10\text{V}; I_D=6.4\text{A}$		0.18	Ω
I_{GSS}	Gate-Body Leakage Current	$V_{GS}=\pm 30\text{V}; V_{DS}=0$		± 100	nA
I_{DSS}	Zero Gate Voltage Drain Current	$V_{DS}=200\text{V}; V_{GS}=0$ $V_{DS}=160\text{V}; V_{GS}=0; T_j=125^{\circ}\text{C}$		10 100	μA
V_{SD}	Forward On-Voltage	$I_S=12.8\text{A}; V_{GS}=0$		1.5	V