

INCREMENTAL HOLLOW-SHAFT ENCODER

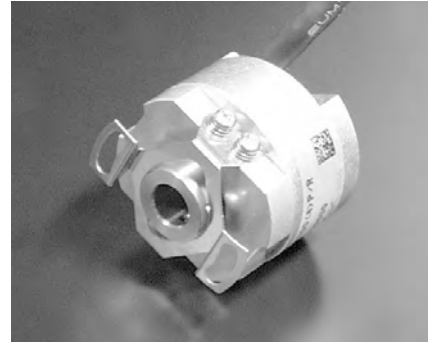

IRH3 Series

● Outer Diameter 35mm ● Length 34mm ● Shaft Diameter 8.0mm

Model Name **IRH3X0 – XXXX – XXX**
 Model Output Pulse (P/R) Function Number

Dimensions

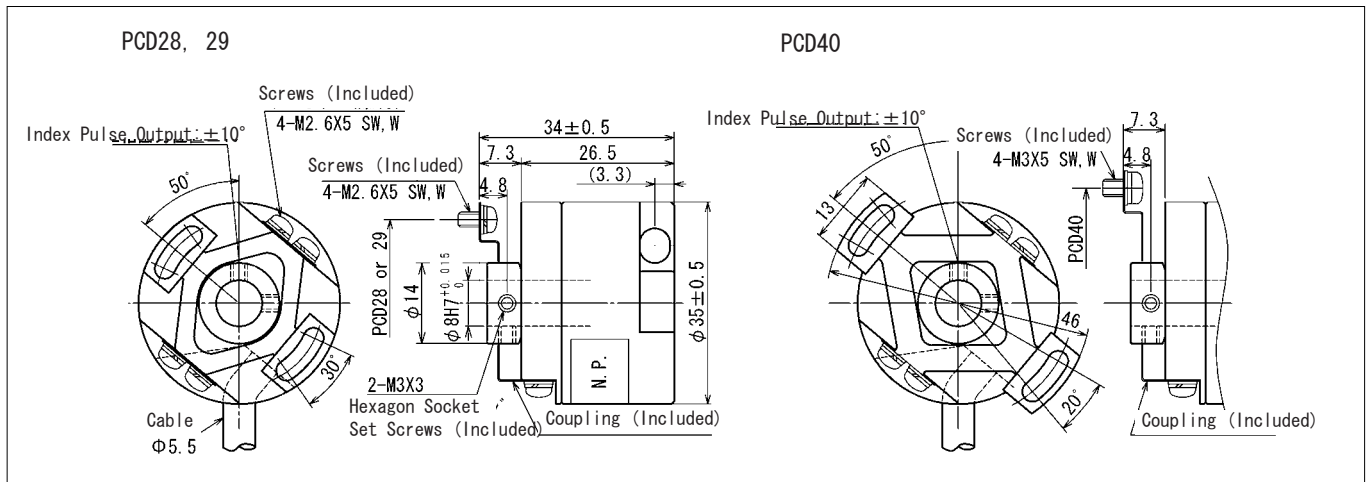

Output Signals

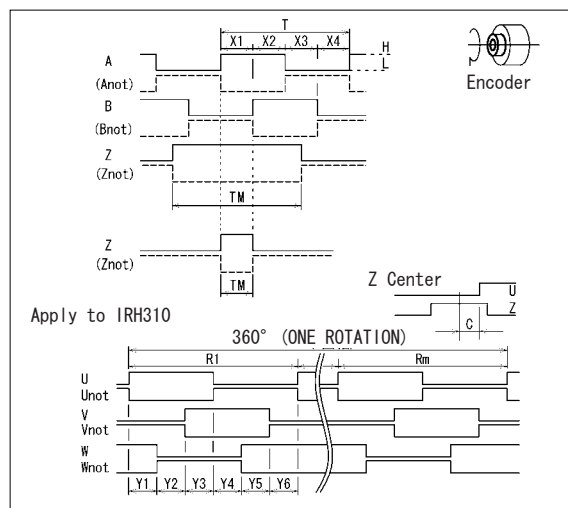

Square-wave Accuracy

~2500P/R	3000P/R	3001~6000P/R (: ×2)
$X1+X2=0.5T \pm 0.1T$	$X1+X2=0.5T \pm 0.1T$	$X1+X2=0.5P \pm 0.15P$
$X2+X3=0.5T \pm 0.1T$	$X2+X3=0.5T \pm 0.1T$	$X2+X3=0.5P \pm 0.15P$
$Xn \geq 0.15T$ (n=1,2,3,4)	$Xn \geq 0.15T$ (n=1,2,3,4)	$Xn \geq 0.1P$ (n=1,2,3,4)
$TM=1.0T \pm 0.5T$	$TM=0.25T \pm 0.1T$ (=X1)	$TM=0.25P \pm 0.15P$ (=X1)
Position relationship of A&B channels and Z channel are not specified.	Position relationship of A&B channels and Z channel are left.	Position relationship of A&B channels and Z channel are left.
$Yn=Rm^\circ / 6 \pm 2^\circ$ (n=1,2,3,4,5,6) (Mechanical Angle)		
$C \leq \pm 2^\circ$ (Mechanical Angle)		

Signal Accuracy

~2500P/R	3000P/R	3001~6000P/R (: ×2)
Accumulative Angle Error : $\leq 0.2T$	Accumulative Angle Error : $\leq 0.3T$	Accumulative Angle Error : $\leq 0.4T$
Pitch Error \boxtimes : $\pm 0.01T$	Pitch Error \boxtimes : $\pm 0.01T$	Pitch Error \boxtimes : $\pm 0.1T$
Adjacent Pitch Error : $\pm 0.005T$	Adjacent Pitch Error : $\pm 0.005T$	

* $T=360^\circ / NI$ (NI: P/R)

* $Rm=360^\circ / Ncs \pm 2^\circ$ (Ncs: CS signal P/R) (Mechanical Angle)

Wire Connection

Color	White	Black	Red	Pink	Olive	Blue	Yellow	Orange	Beige	Brown	Green	Grey	Light Blue	Violet
IRH310	+5V	0V	A	Anot	B	Bnot	Z	Znot	U	Unot	V	Vnot	W	Wnot
IRH320	+5V	0V	A	Anot	B	Bnot	Z	Znot						
IRH360	+Vcc	0V	A	0V	B	0V	Z	0V						

※Shield=FG

■ Electrical Specifications

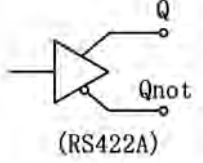
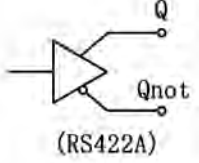
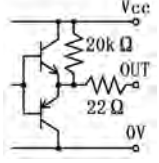
Item/Model	IRH310	IRH320	IRH360
Output Pulse (CS)	1000(4), 2000(4), 2500(4)	500, 600, 1000, 1024, 2000, 2048, 2500, 3000, 4096, 5000, 6000	
Supply Voltage (Vcc)	5V±0.5V	5V±0.5V	10.8V~26.4V
Supply Current (No load)	≤70mA	≤70mA	≤70mA
Output Type	Line Driver	Line Driver	Line Driver
Output Circuit			
Output Voltage ☒ ☒	H	≥2.4V	≥Vcc-4.0V
	L	≤0.5V	≤2.0V
Output Current	±10mA	±10mA	≤40mA
Max. Applied Voltage	—	—	—
Min. Load Resistance	—	—	500Ω
Rise Time	≤100ns	≤100ns	500ns (Typ.)
Fall Time	≤100ns	≤100ns	100ns (Typ.)
Response Frequency	0~300kHz	0~300kHz	0~200kHz
Bypass Capacitor (0V-FG)	0.22μF	0.22μF	0.22μF
Bypass Capacitor (Vcc-FG)	0.22μF	0.22μF	0.22μF
Determinate Time of ABZ signals	Output signal is not stable in 30ms after the power is on. Excluding CS signal.		

■ Mechanical Specifications

Mech. Perm. Speed	6000 ☒ min ⁻¹		
Starting Torque	≤0.005 ☒ N·m	Ta = +25°C	
Moment of Inertia	0.5×10 ⁻⁶ ☒ kg·m ²		
Mounting Shaft	Axial End Play	0.15 ☒ mm	
	Shaft Runout	0.03 ☒ mm	(T.I.R.)
	Perpendicularity	0.1 ☒ m	R15mm
Max. Accel. Speed	40000 ☒ rad/s ²		
Cable Length	1000 ☒ mm	Wire Thickness 0.1mm ² , Diameter 5.5mm, Twist Pair Shield Cable	
Mass	Approx. 0.07 ☒ kg	Without Cable	

■ Environmental Specifications

Operating Temperature	-20~+85 ☒ °C	Without Dewfall
Storage Temperature	-20~+85 ☒ °C	Without Dewfall
Vibration *1	100 ☒ m/s ²	25~2000Hz, X·Y·Z Each Direction 2h
Shock *1	1000 ☒ m/s ²	6ms, Half Sin Pulse, X·Y·Z Each Direction 2 Times
Protection Grade *1	IP66 ☒ Equivalent	No Shaft Rotation

*1 Test Conditions

- Notes ☒ Specifications subject to change without notice.
 ☒ Coupling to be shipped separately.
 ☒ Please specify the size of PCD.

HEIDENHAIN

<http://www.heidenhain.co.jp>

HEIDENHAIN K.K.

Hulic Kojimachi Bldg., 9F
3-2 Kojimachi, Chiyoda-ku,
Tokyo 102-0083 Japan

☎ +81 (0)3 3234 7781

☎ +81 (0)3 3262 2539