

Technical Data Sheet

Infrared Remote-control Receiver Module

IRM-2638TF4

Features

- Photo detector and preamplifier in one package
- Internal filter for PCM frequency
- Improved inner shielding against electrical field disturbance
- TTL and CMOS compatibility
- Low power consumption
- Improved immunity against ambient light
- Suitable burst length ≥ 10 cycles/burst
- Pb free
- BiCMOS manufacture IC ; ESD HBM>4000V ; MM>250V
- The product itself will remain within RoHS compliant version.

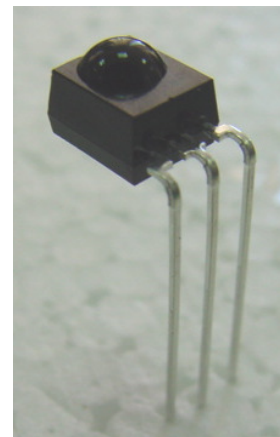

Descriptions

The IRM-2638TF4 is miniaturized receivers for infrared remote control systems. PIN diode and preamplifier are assembled on lead frame, the epoxy package is designed as IR filter. The demodulated output signal can directly be decoded by a microprocessor. IRM-2638TF4 is the standard IR remote control receiver series, supporting all major transmission codes.

Applications

- Light detecting portion of remote control
- AV instruments such as Audio, TV, VCR, CD, MD, etc.
- Home appliances such as Air-conditioner, Fan , etc.
- The other equipments with wireless remote control.
- CATV set top boxes
- Multi-media Equipment

| PART | MATERIAL | COLOR |
|----------|----------|-------|
| Chip | Silicon | Black |
| Compound | Epoxy | Black |

Package Dimensions

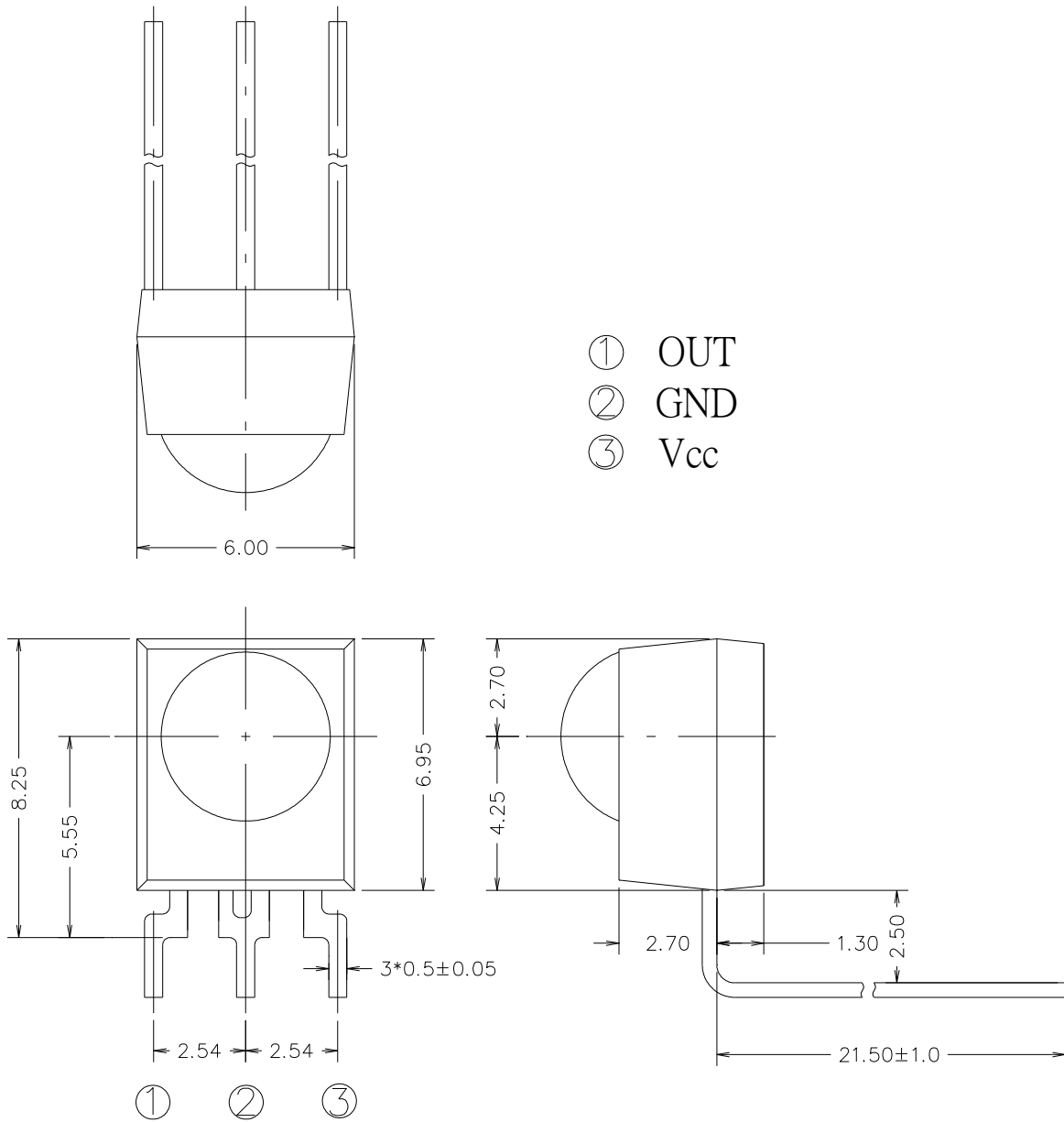

Notes: 1.All dimensions are in millimeters.

2.Tolerances unless dimensions ± 0.3 mm.

Unit:mm

IRM-2638TF4
Absolute Maximum Ratings (Ta=25°C)

| Parameter | Symbol | Rating | Unit | Notice |
|-----------------------|--------|-----------|------|--|
| Supply Voltage | Vcc | 0~6 | V | |
| Operating Temperature | Topr | -25 ~ +80 | °C | |
| Storage Temperature | Tstg | -40 ~ +85 | °C | |
| Soldering Temperature | Tsol | 260 | °C | 4mm from mold body less than 10 seconds |

Recommended Operating Condition

Supply Voltage Rating: Vcc 4.5V to 5.5V, TYP. 5V

Electro-Optical Characteristics (Ta=25°C, and Vcc=5V)

| Parameter | Symbol | MIN. | TYP. | MAX. | Unit | Condition |
|---------------------------|-----------------|------|------|------|---------|-----------------------|
| Consumption Current | Icc | --- | 1.2 | --- | mA | No signal input |
| B.P.F Center Frequency | Fo | --- | 38 | --- | KHz | |
| Peak Wavelength | λ_p | --- | 940 | --- | nm | |
| Reception Distance | L ₀ | 14 | --- | --- | m | At the ray axis *1 |
| | L ₄₅ | 6 | --- | --- | | |
| Half Angle(Horizontal) | Θ_h | --- | 45 | --- | deg | |
| Half Angle(Vertical) | Θ_v | --- | 45 | --- | deg | |
| High Level Pulse Width | T _H | 400 | --- | 800 | μ s | At the ray axis *2 |
| Low Level Pulse Width | T _L | 400 | --- | 800 | μ s | |
| High Level Output Voltage | V _H | 4.5 | --- | --- | V | |
| Low Level Output Voltage | V _L | --- | 0.2 | 0.5 | V | |

Notes:

*1:The ray receiving surface at a vertex and relation to the ray axis in the range of $\theta=0^\circ$ and $\theta=45^\circ$.

*2:A range from 30cm to the arrival distance. Average value of 50 pulses.

Test Method :

The specified electro-optical characteristics is satisfied under the following Conditions at the controllable distance.

①Measurement place

A place that is nothing of extreme light reflected in the room.

②External light

Project the light of ordinary white fluorescent lamps which are not high Frequency lamps and must be less then 10 Lux at the module surface.
($E_e \leq 10\text{Lux}$)

③Standard transmitter

A transmitter whose output is so adjusted as to **$V_o=400\text{mVp-p}$** and the output Wave form shown in Fig.-1.According to the measurement method shown in Fig.-2 the standard transmitter is specified.

However , the infrared photodiode to be used for the transmitter should be $\lambda_p=940\text{nm}, \Delta\lambda=50\text{nm}$. Also, photodiode is used of PD438B($V_r=5\text{V}$).
(Standard light / Light source temperature 2856°K).

④Measuring system

According to the measuring system shown in Fig.-3

Block Diagram :

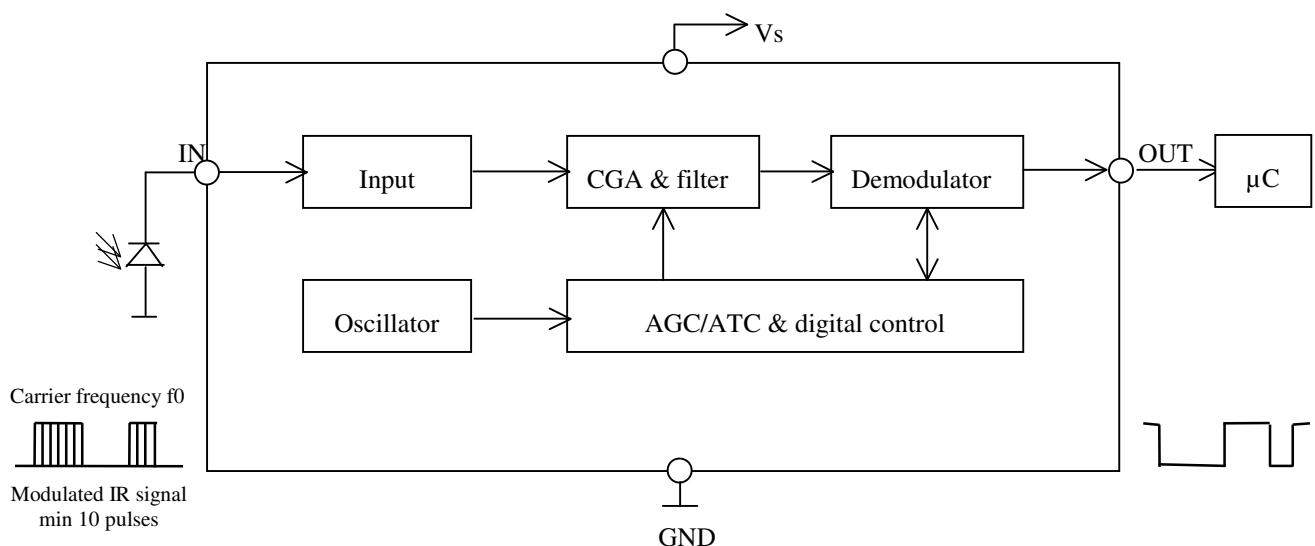

IRM-2638TF4

Application Circuit :

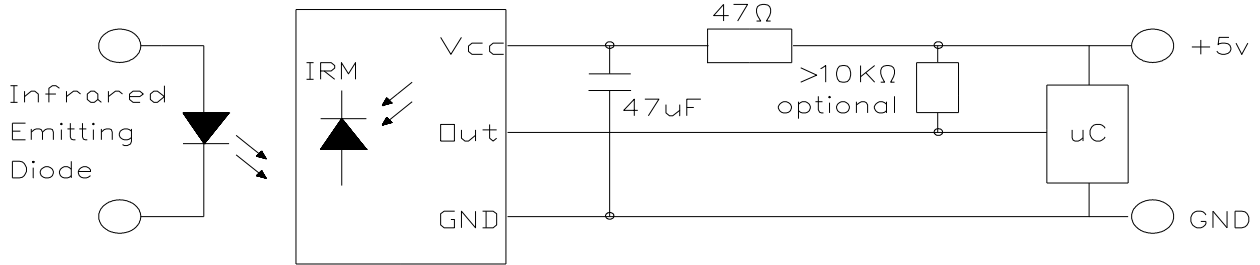

RC Filter should be connected closely between Vcc pin and GND pin.

Fig.-1 Transmitter Wave Form

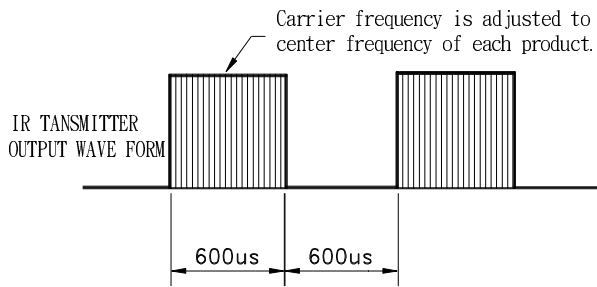

D.U.T output Pulse

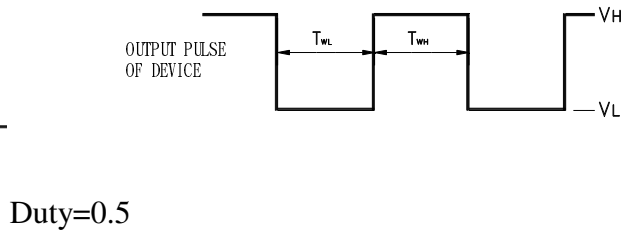

Fig.-2 Measuring Method

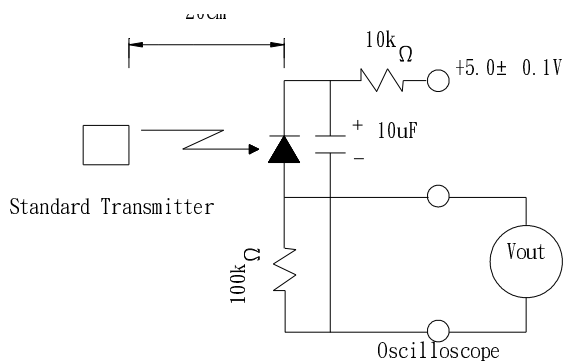
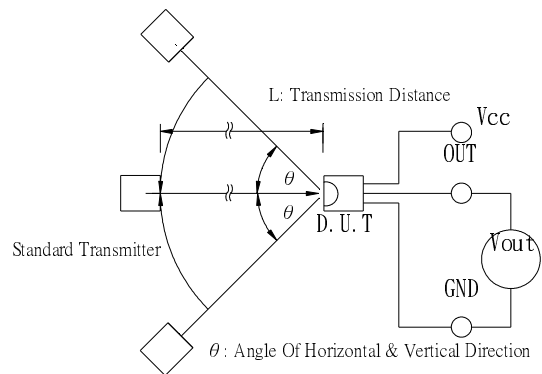

Fig.-3 Measuring System



IRM-2638TF4

The Notice of Application:

Transmission of remote control signal consist of four parts: Encode Part, IR Transmitter Source, IRM device, Decode Part

1. When IRM-2638TF4 code select frequency, it need to well understand the center system of encode part.
2. Strong or weak light of IR Transmitter can affect distance of transmission.
3. When using IRM-2638TF4 device, it requires the composition of code pattern to reach the demand as follows:

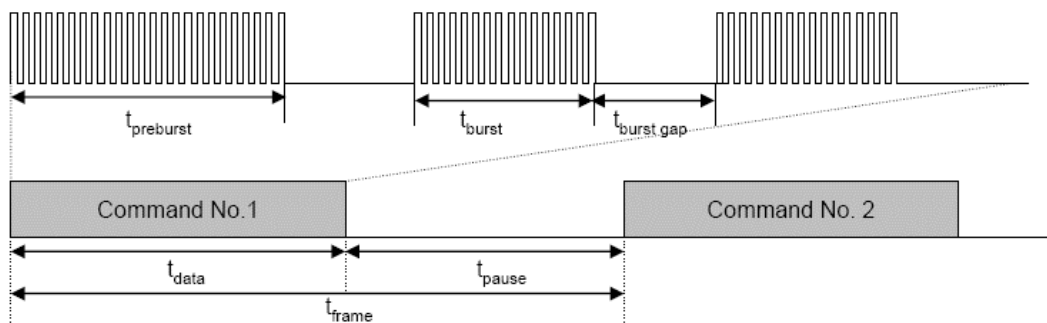

| Minimum t_{burst} (number of pulses per burst) | Minimum t_{burst_gap} (number of pulses between two burst) | Minimum t_{pause} |
|--|--|---------------------|
| 10 pulses | 14 pulses | 25 msec |

4. It needs to ensure the translation range of decode part if it is applied to the pulse-width range.

If the above items hardly assure of its application, it'll cause NG(no good) message from the edge of signal.

IRM-2638TF4 Code Property:

| | | | |
|---------------|---|--------------------------------|---|
| Data format | | Data format | |
| NEC | O | Sony 12 Bit | O |
| RC5 _ Philips | O | Sony 15 Bit | X |
| RC6 _ Philips | O | Sony 20 Bit | X |
| RCA _ Thomson | X | Matsushita | O |
| Toshiba | O | Mitsubishi | O |
| Sharp | O | Zenith | O |
| JVC | O | High data rate (4000 bit/s) | X |

Typical Electro-Optical Characteristics Curves

Fig.-4 Relative Spectral Sensitivity vs. Wavelength

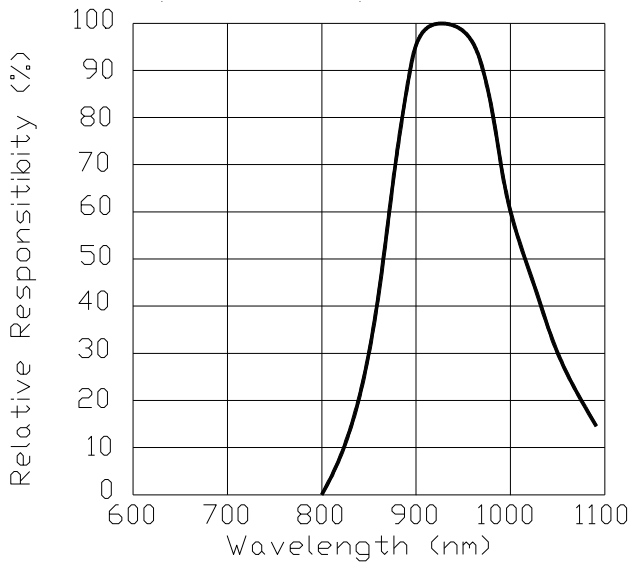

Fig.-5 Relative Transmission Distance vs. Direction

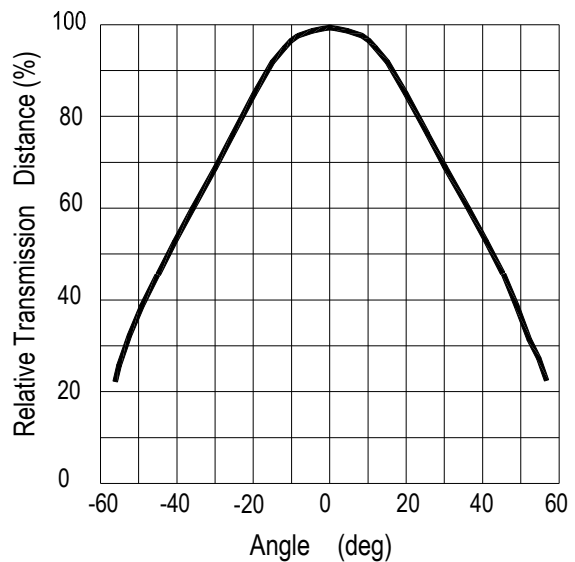

Fig.-6 Output Pulse Length vs. Arrival Distance

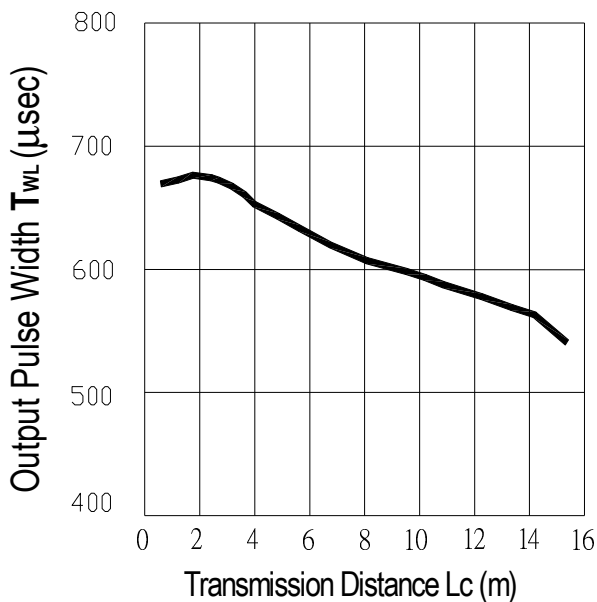
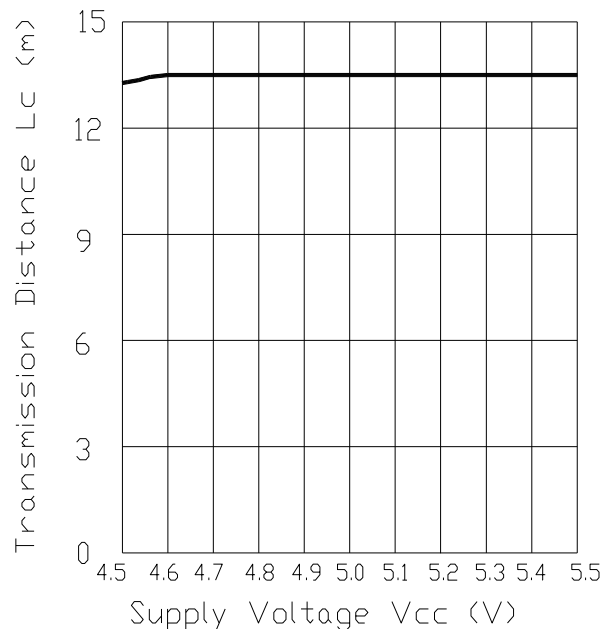

Fig.-7 Arrival Distance vs. Supply Voltage



Typical Electro-Optical Characteristics Curves

Fig.-8 Relative Transmission Distance vs. Center Carrier Frequency

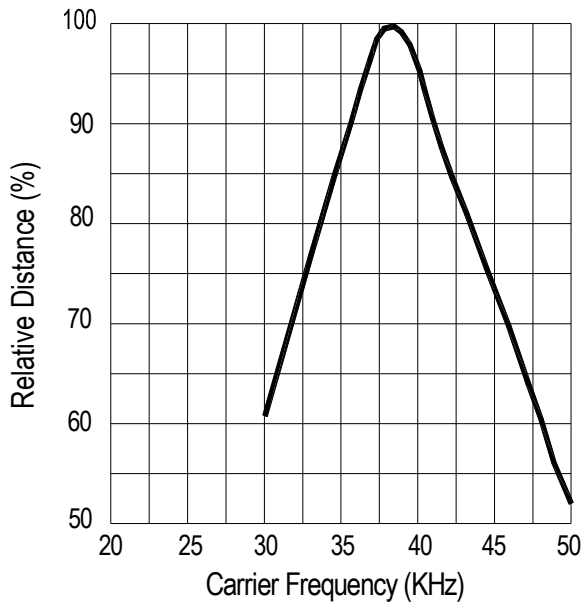
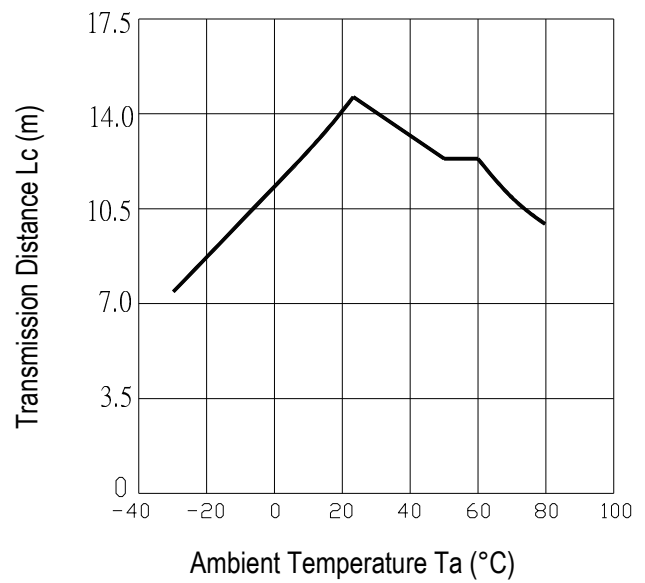

Fig.-9 Arrival Distance vs. Ambient Temperature



Reliability Test Item And Condition

The reliability of products shall be satisfied with items listed below.

Confidence level : 90%

LTPD : 10%

| Test Items | Test Conditions | Failure Judgement Criteria | Samples(n) Defective(c) |
|-----------------------------------|--|---|----------------------------|
| Temperature cycle | 1 cycle -40°C ↔ +100°C (15min)(5min)(15min) 300 cycle test | $L_0 \leq L \times 0.8$ $L_{45} \leq L \times 0.8$ L: Lower specification limit | n=22,c=0 |
| High temperature test | Temp: +100°C Vcc:6V 1000hrs | | n=22,c=0 |
| Low temperature storage | Temp: -40°C 1000hrs | | n=22,c=0 |
| High temperature High humidity | Ta: 85°C ,RH:85% 1000hrs | | n=22,c=0 |
| Solder heat | Temp: 260±5°C 10sec 4mm From the bottom of the package. | | n=22,c=0 |



Packing Quantity Specification

1. 1500 PCS/1Box
2. 10 Boxes/1Carton

Label Form Specification

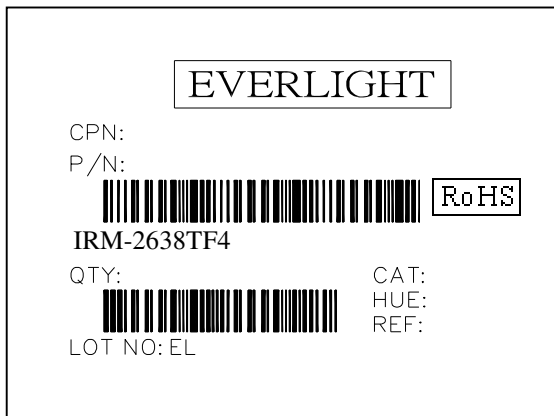

CPN: Customer's Production Number

P/N : Production Number

QTY: Packing Quantity

CAT: Ranks

HUE: None

REF: Reference

LOT No: Lot Num

ber

MADE IN TAIWAN: Production Place

Notes

1. Above specification may be changed without notice. EVERLIGHT will reserve authority on material change for above specification.
2. When using this product, please observe the absolute maximum ratings and the instructions for using outlined in these specification sheets. EVERLIGHT assumes no responsibility for any damage resulting from use of the product which does not comply with the absolute maximum ratings and the instructions included in these specification sheets.
3. These specification sheets include materials protected under copyright of EVERLIGHT corporation. Please don't reproduce or cause anyone to reproduce them without EVERLIGHT's consent.

EVERLIGHT ELECTRONICS CO., LTD.

Office: No 25, Lane 76, Sec 3, Chung Yang Rd,
Tucheng, Taipei 236, Taiwan, R.O.C

Tel: 886-2-2267-2000, 2267-9936

Fax: 886-2267-6244, 2267-6189, 2267-6306

<http://www.everlight.com>