

## 18 CHANNELS, LINEAR LED DRIVER WITH UART INTERFACE

May 2024

### 1 GENERAL DESCRIPTION

The IS32LT3138 is a linear programmable current regulator consisting of 18 output channels capable of up to 100mA each. It has a UART interface compatible with CANFD PHY for communication with a master microcontroller or ECU. It uses a command and response protocol mastered by the host microcontroller to read and write the registers to and from one or multiple IS32LT3138 devices.

Each output can individually support 12-bit PWM dimming and 7-bit DC current adjustment. The outputs can be combined to provide higher current drive capability to max 1.8A.

For added system reliability, the IS32LT3138 integrates fault detection circuitry for open/short string, single LED short, and over temperature conditions. Faults are recorded in registers which can be accessed by an external MCU. To optimize EMI performance, the IS32LT3138 features spread spectrum on the internal PWM and LED channel outputs have phase delay to mitigate EMI and power supply inrush current.

The IS32LT3138 is targeted at the automotive market such as interior accent lighting and exterior tail lighting. It is offered in WFQFN-32 (5mm×5mm) package.

### 2 APPLICATIONS

- Animation Rear Light
- Animation Tail Light
- Animation Daytime Running Light

### 3 FEATURES

- Wide input voltage supply from 4.5V to 16V
- Maximum output voltage 16V
- UART Communication Interface with Lumibus protocol
  - UART interface compatible with CANFD physical layer, 1MHz maximum.
  - UART communication with CRC to ensure robustness of communication
  - Support up to max. 64 addressable devices
  - Watch dog timer
  - Support Fail safe mode
- 18 channels capable of 100mA each
  - $\pm 4.5\%$  @ 100mA bit-to-bit output current mismatch
  - $\pm 5\%$  @ 100mA device-to-device output current accuracy
- Combined for higher current capability with same current accuracy
  - Minimum headroom voltage of 0.5V (Max.) at 100mA
- Individual PWM dimming to each channel
  - 4096 steps (12-bit) PWM duty cycle setting
    - 7+5-bit at 24kHz
    - 12-bit at 244Hz
    - 8-bit at 24kHz
  - Phase delay minimizes inrush current (6 groups)
- Slew rate control and spread spectrum optimize EMI performance
- 64 steps (6-bit) global current setting
- Individual 128 steps (7-bit) DC current adjustment to each channel
- DC Binning support (ADJR pin)
- Fault protection with reporting
  - Fail safe modes selection
  - LED string open/short detect
  - Single LED short detect
  - Programmable fault reporting delay time
  - Programmable over temperature current roll off
  - Thermal shutdown
  - CRC error detection
  - ISET short to GND
- AEC-Q100 Qualified with Temperature Grade 1: -40°C to 125°C
- Operating temperature range (-40°C ~ +125°C)
- WFQFN-32 (5mm×5mm) package
- RoHS & Halogen-Free Compliance
- TSCA Compliance

## 4 TYPICAL APPLICATION CIRCUIT

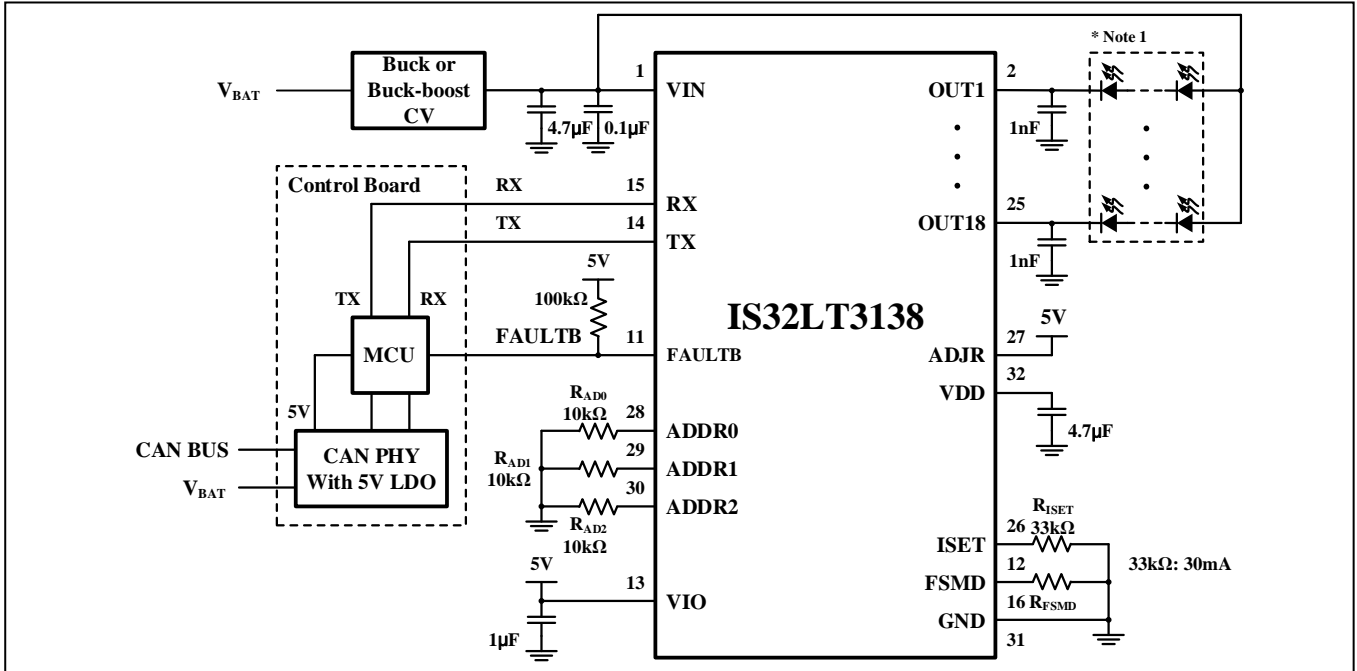

Figure 1 Typical Application Circuit of IS32LT3138 with UART Interface

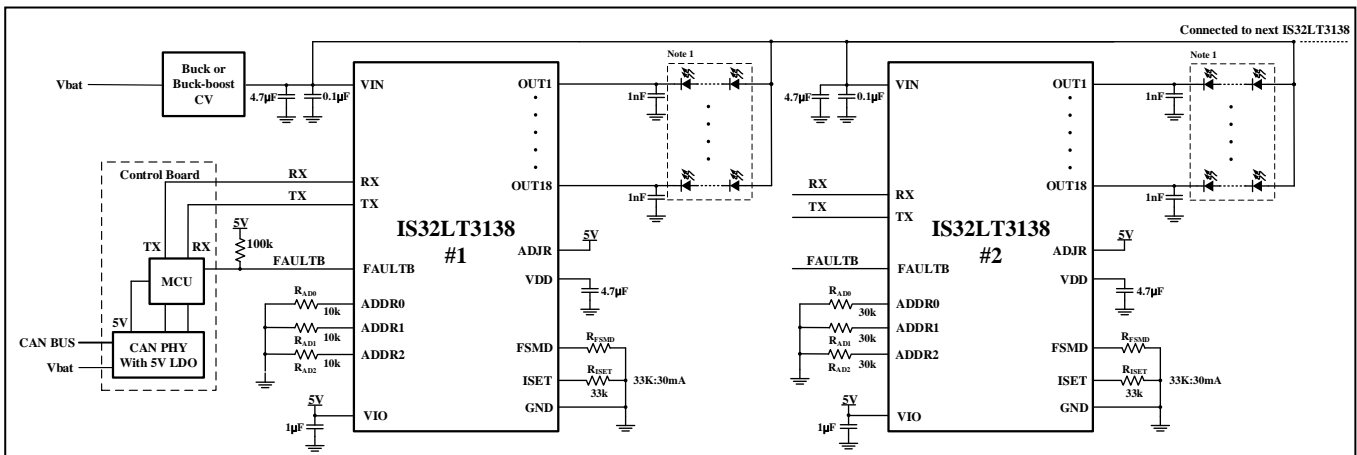

Figure 2 Typical Application Circuit of Multiple IS32LT3138 with UART Interface

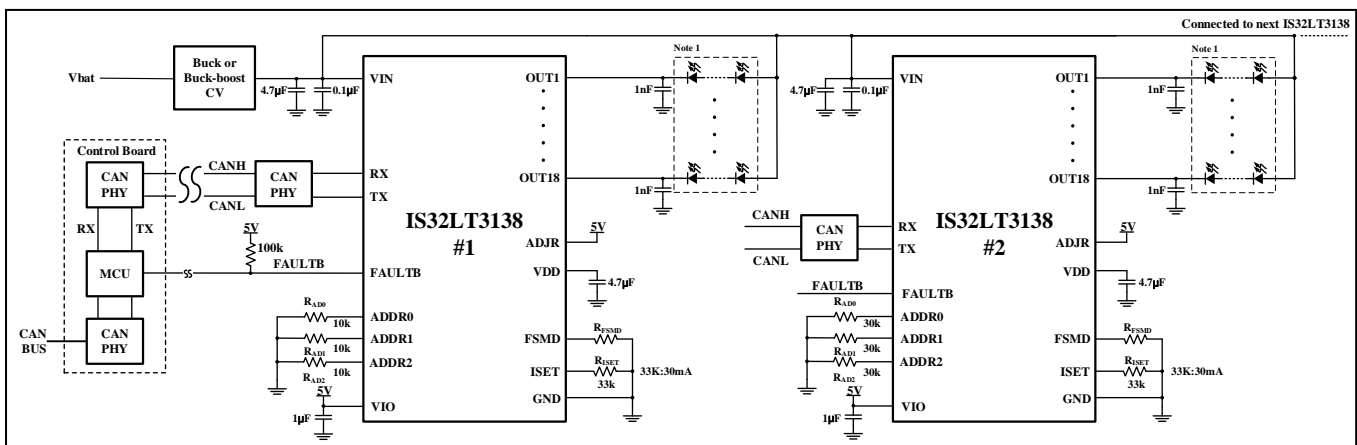
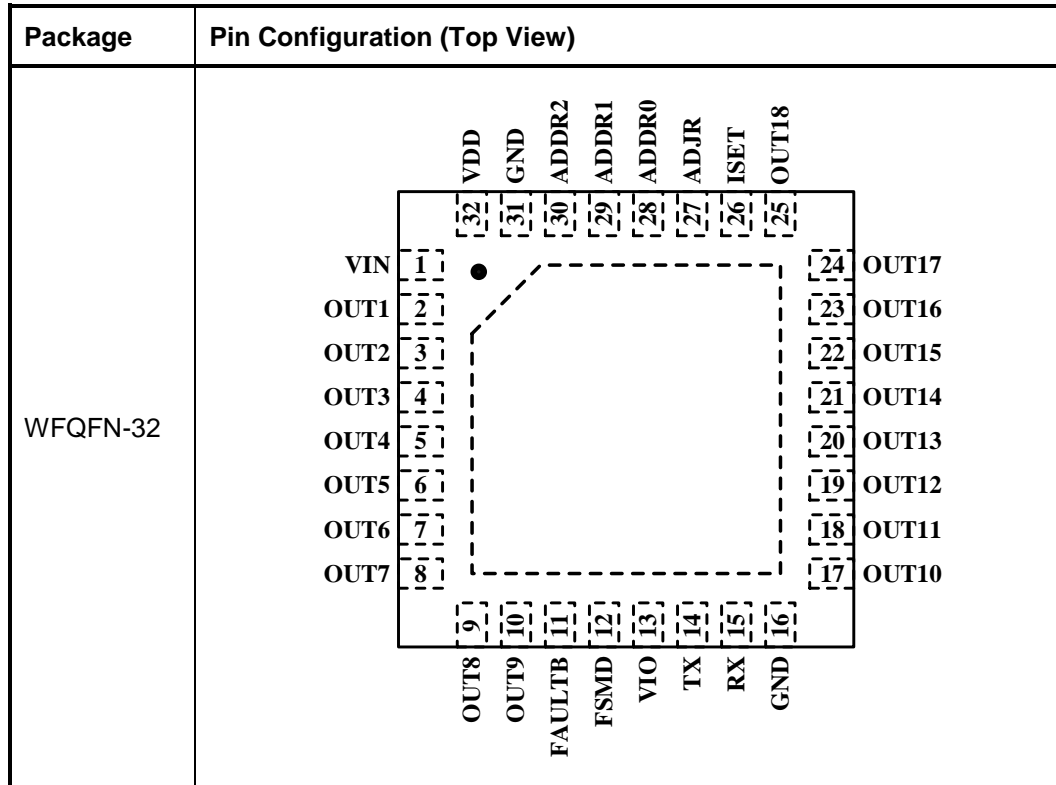

Figure 3 Typical Application Circuit of Multiple IS32LT3138 with External CAN Transceiver for Off-board Long Distance Communication

**Note 1:** The forward voltage variation of output channels (OUT<sub>x</sub>) should be kept as smaller as possible to minimize the heat consumption on device and prevent false fault triggering.

## 5 PIN CONFIGURATION



## DESCRIPTION

No.	Pin	Description
1	VIN	Power supply input.
2~10, 17~25	OUT1~OUT18	Current sink channels.
11	FAULTB	Open drain fault reporting pin. FAULTB pin is open drain output and requires an external pull-up resistor.
12	FSMD	Connect resistor to GND to select fail safe mode.
13	VIO	For TX power supply
14	TX	UART interface transmitted data pin.
15	RX	UART interface received data pin.
16, 31	GND	Ground.
26	ISET	Input pin used to connect an external resistor to set the global output current.
27	ADJR	For analog dimming control
28~30	ADDR0~ADDR2	Address setting. Connect different values resistors from these pins to GND to assign device address.
32	VDD	4.2V LDO output. Connect a 4.7 $\mu$ F X7R capacitor to GND.
	Thermal Pad	Must be connected to GND. Connect thermal pad to external GND plane on board for better thermal performance.

# IS32LT3138



## 6 ORDERING INFORMATION

Automotive Range: -40°C to +125°C

Order Part No.	Package	QTY/Reel
IS32LT3138-QWLA3-TR IS32LT3138-QWLCA3-TR (Note 2)	WFQFN-32, Lead-free	2500

**Note 2:** IS32LT3138-QWLCA3-TR is with copper wire bonding.

Copyright © 2024 Lumissil Microsystems. All rights reserved. Lumissil Microsystems reserves the right to make changes to this specification and its products at any time without notice. Lumissil Microsystems assumes no liability arising out of the application or use of any information, products or services described herein. Customers are advised to obtain the latest version of this device specification before relying on any published information and before placing orders for products.

Lumissil Microsystems does not recommend the use of any of its products in life support applications where the failure or malfunction of the product can reasonably be expected to cause failure of the life support system or to significantly affect its safety or effectiveness. Products are not authorized for use in such applications unless Lumissil Microsystems receives written assurance to its satisfaction, that:

- a.) the risk of injury or damage has been minimized;
- b.) the user assume all such risks; and
- c.) potential liability of Lumissil Microsystems is adequately protected under the circumstances

## 7 SPECIFICATIONS

### 7.1 ABSOLUTE MAXIMUM RATINGS

Supply voltage, $V_{IN}$	-0.3V ~ 20.0V
Voltage at TX, RX, ADDR <sub>x</sub> , ISET, VDD, VIO, ADJR, FSMD	-0.3V ~ 6V
Voltage at OUT1 to OUT18, FAULTB	+20V
Maximum junction temperature, $T_{JMAX}$	+150°C
Storage temperature range, $T_{STG}$	-65°C ~ +150°C
Operating temperature range, $T_A=T_J$	-40°C ~ +150°C
Package thermal resistance, junction to ambient (4-layer standard test PCB based on JESD 51-2A), $\theta_{JA}$	37.7°C/W
Package thermal resistance, junction to thermal PAD (4-layer standard test PCB based on JESD 51-2A), $\theta_{JP}$	2.067°C/W
ESD (HBM)	±2.5kV
ESD (CDM)	±750V

**Note 3:** Stresses beyond those listed under “Absolute Maximum Ratings” may cause permanent damage to the device. These are stress ratings only and functional operation of the device at these or any other condition beyond those indicated in the operational sections of the specifications is not implied. Exposure to absolute maximum rating conditions for extended periods may affect device reliability.

### 7.2 ELECTRICAL CHARACTERISTICS

$V_{IN}=12V$ ,  $T_J=T_A=25^\circ C$ , unless otherwise noted. (Note 6)

Symbol	Parameter	Condition	Min.	Typ.	Max.	Unit
$V_{IN}$	Supply voltage		4.5		16	V
$I_{OUT}$	Maximum output current	$R_{ISET}=10k\Omega$ , $GCC=0x3F$ , $SCAx=0x7F$ , $PWM=0xFFFF$	93.5	100	106.5	mA
	Output current	$R_{ISET}=33k\Omega$ , $GCC=0x3F$ , $SCAx=0x7F$ , $PWM=0xFFFF$	27.9	30	32.1	mA
$\Delta I_{MAT}$	$I_{OUT}$ mismatch (bit to bit) (Note 4)	$I_{OUT}=30mA$	-6.5		6.5	%
		$I_{OUT}=100mA$	-4.5		4.5	%
$\Delta I_{OUT}$	$I_{OUT}$ accuracy (device to device) (Note 5)	$I_{OUT}=30mA$	-5		5	%
		$I_{OUT}=100mA$	-5		5	%
$V_{HR}$	Headroom voltage	$I_{OUT}=100mA$		0.34	0.5	V
		$I_{OUT}=30mA$		0.2	0.4	V
$I_{CC}$	Quiescent power supply current	$R_{ISET}=33k\Omega$ , $GCC=0x3F$ , $SCAx=0x7F$ , $PWM=0$	3	4.5	6.5	mA
$V_{ISET}$	ISET voltage	$R_{ISET}=10k\Omega$ , $GCC=0x3F$ , $SCAx=0x7F$ , $PWM=0xFFFF$	1.94	2.0	2.06	V
$I_{OZ}$	Output leakage current	$PWM=SL=GCC=0$ , $V_{OUT}=16V$			1	$\mu A$
$f_{OUT}$	PWM frequency of output	Frequency setting= 24kHz, 8bit PWM mode	21.6	24	26.4	kHz
		Frequency setting= 24kHz, 7+5bit PWM mode, $PWM>31/4096$	21.6	24	26.4	kHz
		Frequency setting= 244Hz, 12bit PWM mode	219	244	269	Hz

# IS32LT3138

## 7.3 ELECTRICAL CHARACTERISTICS (CONTINUE)

$V_{IN} = 12V$ ,  $T_J = T_A = 25^\circ C$ , unless otherwise noted. (Note 6)

Symbol	Parameter	Condition	Min.	Typ.	Max.	Unit
$T_{SD}$	Thermal shutdown			168		$^\circ C$
$T_{SD\_HYS}$	Thermal shutdown hysteresis			15		$^\circ C$
$V_{PD\_FAULTB}$	FAULTB pin pull-down capability	$I_{SINK} = 2mA$		0.1	0.2	V
$I_{LKG\_FAULTB}$	FAULTB pin leakage current	$V_{PULL-UP} = 16V$			1	$\mu A$
$V_{IH\_RX}$	Logic "1" input voltage		2			V
$V_{IL\_RX}$	Logic "0" input voltage				0.7	V
$V_{OL(TX)}$	LOW level output voltage	$I_{SINK} = 5mA$			0.3	V
$V_{OH(TX)}$	High level output voltage	$I_{SOURCE} = 5mA$	$V_{IO-0.3}$		$V_{IO}$	V
$V_{TH1\_AD/FS}$	ADDR0/ADDR1/ADDR2/FSMD threshold1		0.9	1	1.1	V
$V_{TH2\_AD/FS}$	ADDR0/ADDR1/ADDR2/FSMD threshold2		1.85	2	2.15	V
$V_{TH3\_AD/FS}$	ADDR0/ADDR1/ADDR2/FSMD threshold3		2.8	3	3.2	V
$I_{AD/FS}$	ADDR/FS source current		46	50	54	$\mu A$
$V_{SC\_FL}$	LED string short detection falling threshold	$R_{SET} = 33k\Omega$ , $GCC = 0x3F$ , $SCAx = 0x7F$ , $PWM = 0xFFFF$ , measured at $V_{IN} - V_{OUTx}$ $SHORT\_FLT(4Bh) = "000"$	0.5	1		V
$V_{SC\_RS}$	LED string short detection rising threshold	$R_{SET} = 33k\Omega$ , $GCC = 0x3F$ , $SCAx = 0x7F$ , $PWM = 0xFFFF$ , measured at $V_{IN} - V_{OUTx}$ $SHORT\_FLT(4Bh) = "000"$		1.2		V
$V_{OC\_FL}$	LED string open detection falling threshold	$R_{SET} = 33k\Omega$ , $GCC = 0x3F$ , $SCAx = 0x7F$ , $PWM = 0xFFFF$ , measured at $OUTx$	50	100		mV
$V_{OC\_RS}$	LED string open detection rising threshold	$R_{SET} = 33k\Omega$ , $GCC = 0x3F$ , $SCAx = 0x7F$ , $PWM = 0xFFFF$ , measured at $OUTx$		167		mV
$V_{DD}$	LDOOUT output voltage		4.08	4.2	4.32	V
$I_{DD\_MAX}$	LDOOUT output current capability	$V_{IN} > 4.5V$ , $V_{DD} > 3.8V$			50	mA
$I_{DD\_LIM}$	LDOOUT output current limit	$V_{IN} = 12V$ , $V_{DD} = 0V$	60			mA
$V_{DD\_UV}$	LDOOUT undervoltage-lockout threshold	Voltage falling, IC disabled		3.7		V
$V_{DD\_UVHY}$	VDD undervoltage-lockout hysteresis			100		mV

## 7.4 ELECTRICAL CHARACTERISTICS (CONTINUE)

V<sub>IN</sub>= 12V, T<sub>J</sub>= T<sub>A</sub>= 25°C, unless otherwise noted. (Note 6)

Symbol	Parameter	Condition	Min.	Typ.	Max.	Unit
ΔI <sub>CTRL_1</sub>	I <sub>OUT</sub> mismatch (bit to bit)	V <sub>ADJ</sub> = 0.6V	-3		3	%
ΔI <sub>CTRL_2</sub>		V <sub>ADJ</sub> = 1.4V	-3		3	%
V <sub>SLSTH</sub>	Single LED short detect threshold	SLSTH (41h~49h) = "0010"		3.9		V
V <sub>F_UVLO</sub>	Single LED short/String open detect UVLO	FS_FLTL (4Bh) = "00000100"		8		V
V <sub>IO</sub>	TX power supply		3		5.5	V
V <sub>VIN_UV</sub>	VIN undervoltage-lockout threshold	Voltage falling, IC disable		3.7		V
V <sub>VIN_UVHY</sub>	VIN undervoltage-lockout hysteresis			100		mV
f <sub>OSC</sub>	System clock frequency		32.34	33	33.66	MHz

**Note 4:** I<sub>OUT</sub> mismatch (bit to bit) ΔI<sub>MAT</sub> is calculated:

$$\Delta I_{MAT} = \text{MAX} \left( \text{ABS} \left( \frac{I_{OUTn}(n = 1 \sim 18)}{I_{OUT1} + I_{OUT2} + \dots + I_{OUT18}} - 1 \right) \right) \times 100\%$$

**Note 5:** I<sub>OUT</sub> accuracy (device to device) ΔI<sub>OUT</sub> is calculated:

$$\Delta I_{OUT} = \text{ABS} \left( \frac{I_{OUT1} + I_{OUT2} + \dots + I_{OUT18} - I_{OUT(TYP)}}{I_{OUT(TYP)}} \right) \times 100\%$$

When R<sub>ISSET</sub>=10kΩ, I<sub>OUT(TYP)</sub> = 100mA; and when R<sub>ISSET</sub>=33kΩ, I<sub>OUT(TYP)</sub> = 30mA.

**Note 6:** Production testing of the device is performed at 25°C.

**Note 7:** Guaranteed by design.

## 8 FUNCTIONAL BLOCK DIAGRAM

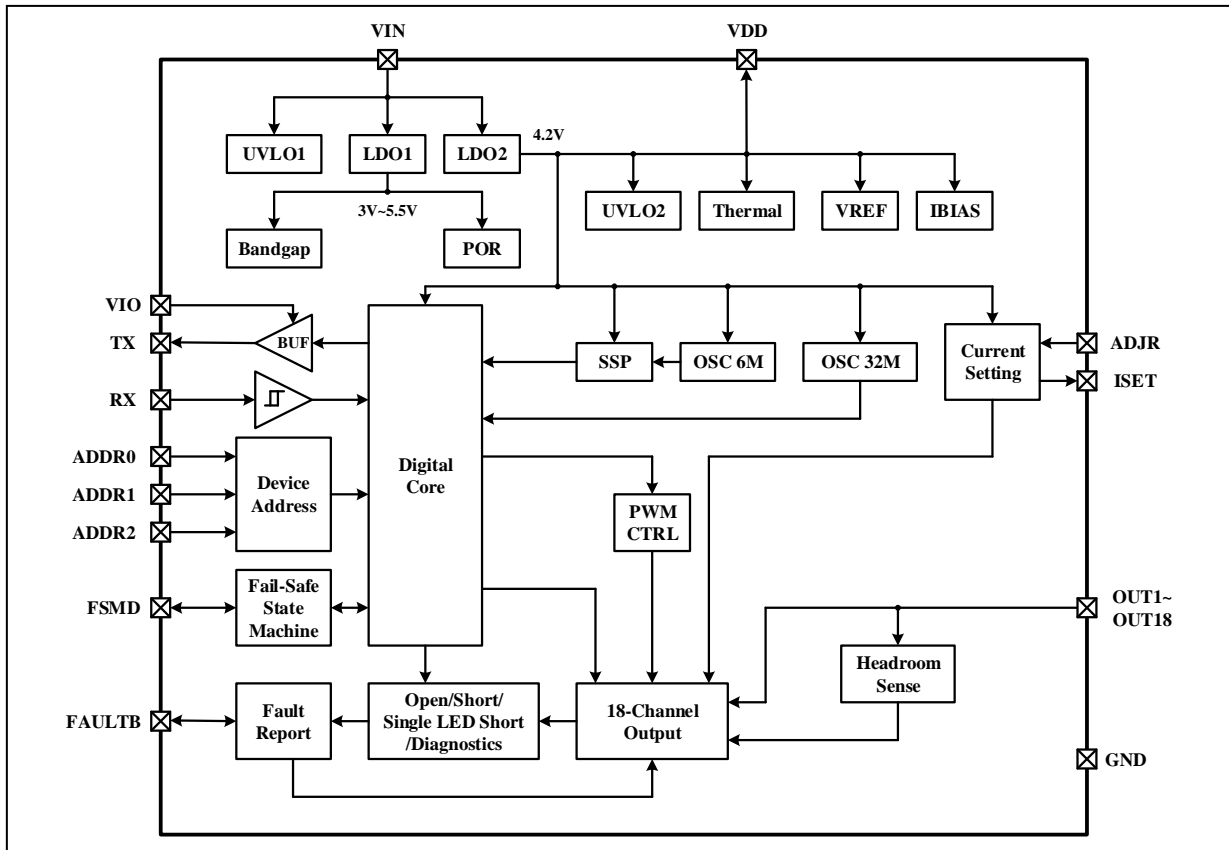



## 9 APPLICATION INFORMATION

### 9.1 OVERVIEW

The IS32LT3138 is an automotive 18-channel LED driver with a UART interface for individual control of each LED string. Each channel is a constant current sink capable of up to 100mA and supports both DC adjustment and PWM dimming. The output current and PWM duty cycle of each channel can be individually configured through the UART interface. For high current LED applications, multiple output channels can be combined in parallel.

For added system reliability, the IS32LT3138 features various fault protections, including LED string open, LED string shorted, single LED shorted, overcurrent (ISET pin shorted), over temperature, CRC error and watchdog timeout (fail-safe modes) conditions for robust operation. Detection of these failures is reported by a dedicated reporting pin, FAULTB. There are also dedicated flag bits in registers for each failure which can be read back by the external host MCU through the interfaces. To optimize EMI performance, the IS32LT3138 features spread spectrum on the internal PWM base clock to spread the total electromagnetic emitting energy into a wider range that significantly degrades the peak energy of EMI. In addition, the output current source ON/OFF transitions during PWM dimming have a slew rate control and programmable phase delay to mitigate EMI and power supply inrush current.

The IS32LT3138 interface is UART, and it supports up to 64 slave IS32LT3138 devices. The device address can be configured by the three address pins. The UART receives data to control all output channels and sends back fault information to the host MCU. The UART interface in conjunction with an external standard CAN transceiver enables long distance communication with a host MCU placed outside of the lamp module (as shown in Figure 4). Based on the CAN physical layer, it achieves excellent EMC and EMI performance. The embedded CRC correction of the UART data stream can ensure robust communication in automotive environments. The UART interface is easily supported by most MCUs in the market.

To further increase robustness, the fail-safe mode of the device allows automatic switching to fail-safe state in case of communication loss, for example, host MCU failure or communication cables broken. The device supports different fail-safe modes configured by the FSMD pin.

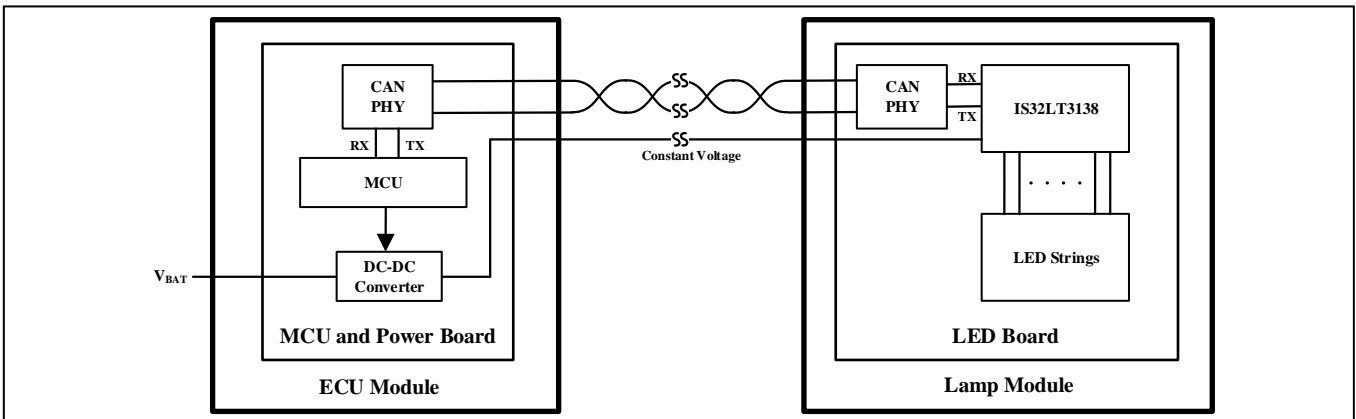

Figure 4 UART Interface with External CAN Transceiver for Outside Module Long Distance Communication

### 9.2 POWER SUPPLY

#### 9.2.1 VIN UNDERVOLTAGE-LOCKOUT (UVLO)

The IS32LT3138 features an undervoltage-lockout (UVLO) function on the VIN pin to prevent unintended operation at too low supply voltages. UVLO threshold is an internally fixed value and cannot be adjusted. Entering UVLO will reset all registers to their default value. The device is disabled when the VIN voltage drops below  $V_{VIN\_UV}$  and automatically resumes normal operation when the VIN voltage rises above  $(V_{VIN\_UV} + V_{VIN\_UVHY})$ .

#### 9.2.2 INTERNAL 4.2V LINEAR REGULATOR (VDD)

The IS32LT3138 device integrates an internal linear regulator (LDO) with 4.2V (Typ.) and  $I_{DD\_MAX}$  current capability to provide power supply to the internal analog and digital circuits. During operation, the internal circuitry can be subject to transient currents from this linear regulator. Therefore, a 4.7 $\mu$ F low ESR, X7R type ceramic capacitor is necessary from VDD pin to GND, it must be placed as close to the VDD pin as possible. This linear regulator also has the UVLO feature. The device is disabled when the VDD voltage drops below  $V_{DD\_UV}$  and resumes normal operation when the VDD voltage rises above  $(V_{DD\_UV})$ . Entering UVLO will reset all registers to their default value. An  $I_{DD\_LIM}$  current limit on VDD pin protects the IS32LT3138 from VDD output overload or short-circuit conditions.

# IS32LT3138

## 9.2.3 VIO VOLTAGE SUPPLY

The positive voltage rail of the UART interface is supplied with the VIO pin which must be connected to a proper voltage source. Usually, the VIO pin should be connected to the same power supply as the MCU. If a 5V MCU is used for IS32LT3138 control, the VIO pin can be directly connected to the VDD pin.

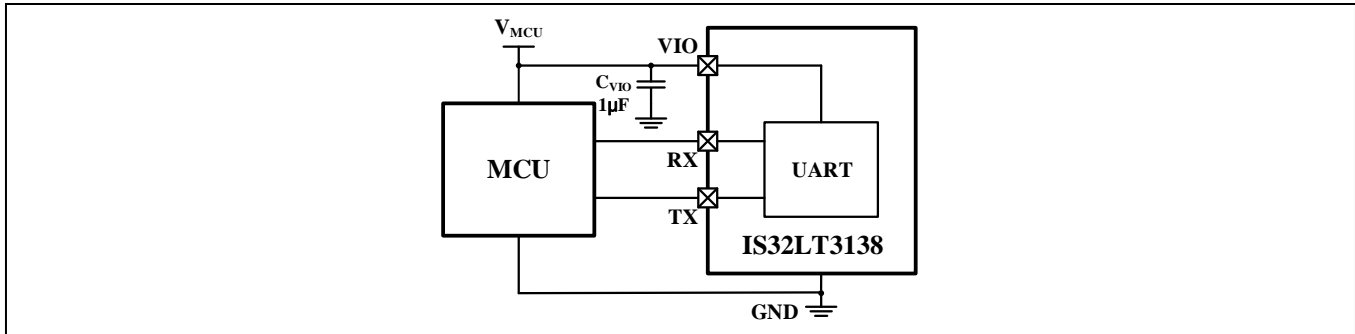

Figure 5 VIO Voltage Supply

## 9.3 OUTPUT CURRENT SETTING

The full DC output current ( $I_{OUT\_FU}$ ) for each channel is set with resistor ( $R_{ISET}$ ) connected from the ISET pin to GND. This current set resistor is computed using the following equation:

If the CM bit in the CONFIG register (00h) is set to “0”:

$$I_{OUT\_FU} = \frac{V_{ISET}}{R_{ISET}} \times 500 \quad (1)$$

Where  $V_{ISET}$  is the voltage of ISET pin, when  $V_{ADJ}$  is lower than 2V (typ.),

$$I_{OUT\_FU} = \frac{V_{ADJ}}{R_{ISET}} \times 500 \quad (2)$$

( $10k\Omega \leq R_{ISET} \leq 75k\Omega$ )

If the CM bit in the CONFIG register (00h) is set to “1”:

$$I_{OUT\_FU} = \frac{V_{ISET}}{R_{ISET}} \times 165 \quad (3)$$

Where  $V_{ISET}$  is the voltage of ISET pin, when  $V_{ADJ}$  is lower than 2V (typ.),

$$I_{OUT\_FU} = \frac{V_{ADJ}}{R_{ISET}} \times 165 \quad (4)$$

( $10k\Omega \leq R_{ISET} \leq 75k\Omega$ )

It is recommended that  $R_{ISET}$  be a 1% accuracy resistor with good temperature characteristic to ensure stable output current.  $R_{ISET}$  must be placed as close to ISET pin as possible on PCB layout to avoid noise interference and ground bounce. The device is protected from an output overcurrent condition caused by  $R_{ISET}$  resistor. The output current is reduced to 17mA (Typ.) if the ISET pin is shorted to ground or  $R_{ISET}$  resistor value is too low.

When  $R_{ISET}$  is fixed, the DC output current for each channel can be further adjusted in 64-steps by the GCC[5:0] bits in the GC\_CTRL register (01h). Furthermore, based on the GCC[5:0] setting, each channel also supports individual 128-step programmable DC output current adjustment. This feature can be used to set binning values for output LEDs or to calibrate the LEDs to achieve high brightness homogeneity based on an external visual calibration system to further save binning cost. The 7-bit Scaling Registers SCAX (14h~25h) individually set the DC output current of each channel.

GCC[5:0] and SCAX control the OUTx current ( $I_{OUTx}$ ) as shown in following equation:

$$I_{OUTx} = I_{OUT\_FU} \times \frac{GCC}{64} \times \frac{SCAx}{128} \quad (5)$$

Where, x is from 1 to 18 for different output channel.

$$GCC = \sum_{n=0}^5 D[n] \cdot 2^n \quad (6)$$

$$SCAx = \sum_{n=0}^6 D[n] \cdot 2^n \quad (7)$$

For example: assume GCC[5:0] = 0x05 and SCA1 = 0x40. GCC = 5. Then the DC output current of OUT1 is:

$$I_{OUT1} = I_{OUT\_FU} \times \frac{5}{64} \times \frac{64}{128}$$

If any channel(s) are unused, please connect the corresponding OUTx pin(s) to the GND pin to avoid false fault detection and set the corresponding PWM and scaling registers to “0x00” to turn off these output(s).

## 9.4 ANALOG DIMMING

The IS32LT3138 offers an analog dimming input pin, ADJR. The dimming voltage range of ADJR pin is 0.06V to 2V. The global output current can be regulated by the ADJR pin voltage. If the analog dimming pin ADJR is pulled up above 2V, analog dimming is disabled, and the output current is 100% (full current). When the ADJR pin is driven below 2V, analog dimming is enabled, and the pin voltage (0.06~2V) will proportionally control the output current.

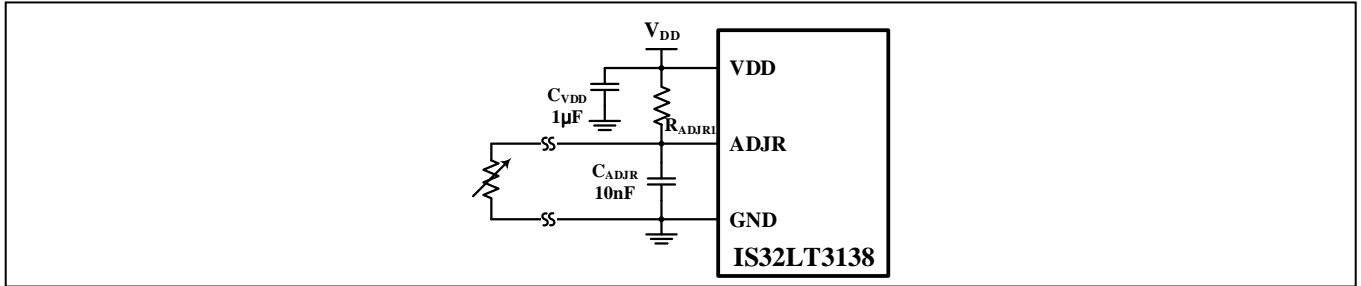

**Figure 6** IS32LT3138 Analog Dimming for LED Binning

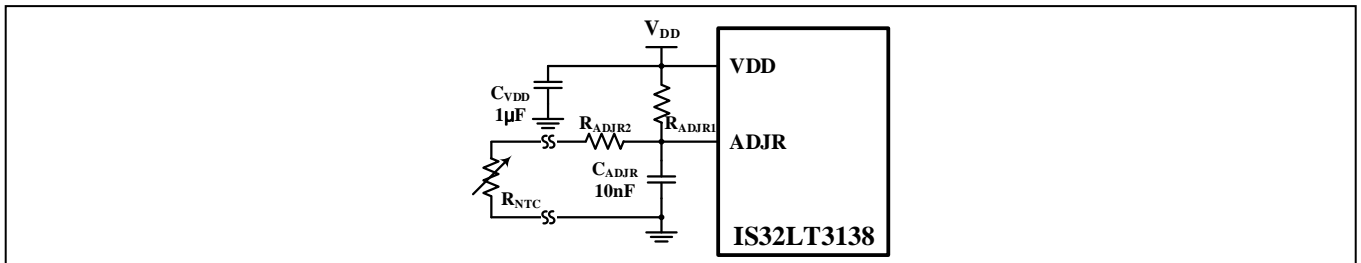

**Figure 7** IS32LT3138 Analog Dimming for Thermal Roll-off

The ADJR pin can be used to fine tune the output current for LED binning during mass-production. The ADJR pin can also be used in conjunction with an NTC thermistor to provide over temperature current roll-off protection for the LED load or the system. As shown in Figure 6 and Figure 7, the IS32LT3138 can perform either LED binning or thermal roll-off function, not both at the same time.

## 9.5 PWM DIMMING

The IS32LT3138 integrates independent 12-bit PWM generators for each output channel. The output current for each channel is turned on and off as controlled by the PWM generator. The average current of each output channel can be adjusted by its PWM duty cycle to control the LED channel brightness. The PWM Registers (26h~40h) individually set the PWM duty cycle for each channel.

The PWM dimming frequency is programmable by the CONFIG register (00h). The maximum PWM frequency can be up to 24kHz (Typ.). Due to the output current slew rate control, a high frequency PWM signal has a shorter period time that will degrade the PWM dimming linearity. Therefore, a low frequency PWM signal is good for achieving better dimming contrast ratio. At a 100Hz~500Hz PWM frequency, the dimming duty cycle can be varied from 100% down to 1% or lower. Select the PWM dimming frequency based on the minimum brightness requirement for the application.

The PWM generators dim the LEDs by its duty cycle:

$$I_{OUTx\_PWM} = I_{OUTx} \times D_{PWMx} \quad (8)$$

Where,  $D_{PWMx}$  is duty cycle of each channel independently programmed by PWM Registers (26h~40h), in 12bit or 7+5-bit PWM mode:

$$D_{PWMx} = \frac{\sum_{n=0}^{11} D[n] \cdot 2^n}{4096} \quad (9)$$

In 8bit PWM mode:

$$D_{PWMx} = \frac{\sum_{n=4}^{11} D[n] \cdot 2^n}{256} \quad (10)$$

## 9.5.1 PWM SPREAD SPECTRUM

The IS32LT3138 includes a spread spectrum feature on PWM base clock to optimize EMI performance. The spread spectrum function helps spread the total electromagnetic emitting energy into a wider range that significantly degrades the peak energy of EMI. With spread spectrum, the EMI test can be passed with smaller size and lower cost filter circuit. Spread spectrum is enabled/disabled by the SSCCFG register (4Ah).

## 9.5.2 PWM PHASE DELAY

To mitigate transient current generation and power supply ripple, the IS32LT3138 features PWM phase delay. When PWM phase delay is disabled (PHASE\_CTRL(03h) is set to "0x00", default value is 0x01 phase delay enable), all channels are simultaneously turned on at the beginning of each PWM cycle. This will result in large current draw from power supply leading to high voltage ripple on the power supply rail. As shown in figure 8.

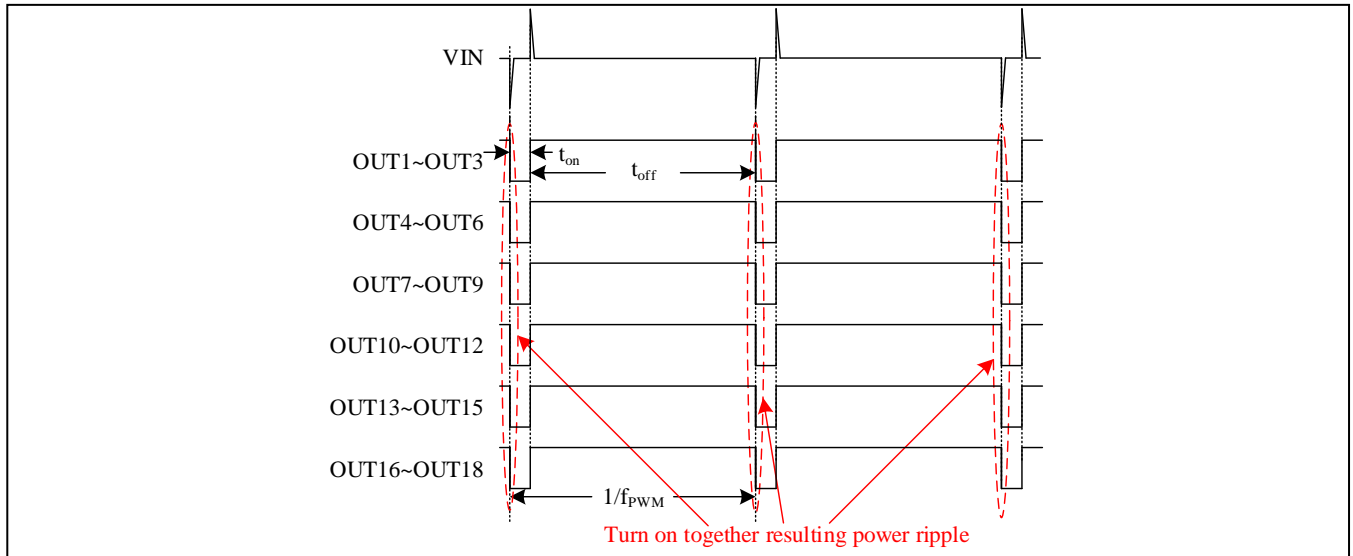

Figure 8 PWM Phase Delay Disabled

The IS32LT3138 divides 18 output channels into 6 groups to perform PWM phase delay, OUT1&OUT2&OUT3 as group 1, OUT4&OUT5&OUT6 as group 2, ...OUT16&OUT17&OUT18 as group 6. When the PDE bit in the PHASE\_CTRL register (03h) is set to "1", the phase delay is enabled, starting each group in turn from each PWM cycle. The  $t_{DELAY\_1}$  is interval delay time between group 1 & group 2, group 3 & group 4, Group 5 & group 6, group 6 & group 1, and  $t_{DELAY\_1}$  is 1/8 PWM cycle ( $1/8f_{PWM}$ ). The  $t_{DELAY\_2}$  is interval delay time between group 2 & group 3, group 4 & group 5, and  $t_{DELAY\_2}$  is 1/4 PWM cycle ( $1/4f_{PWM}$ ). This minimizes the voltage ripple on the VIN power supply rail. As shown in figure 9.

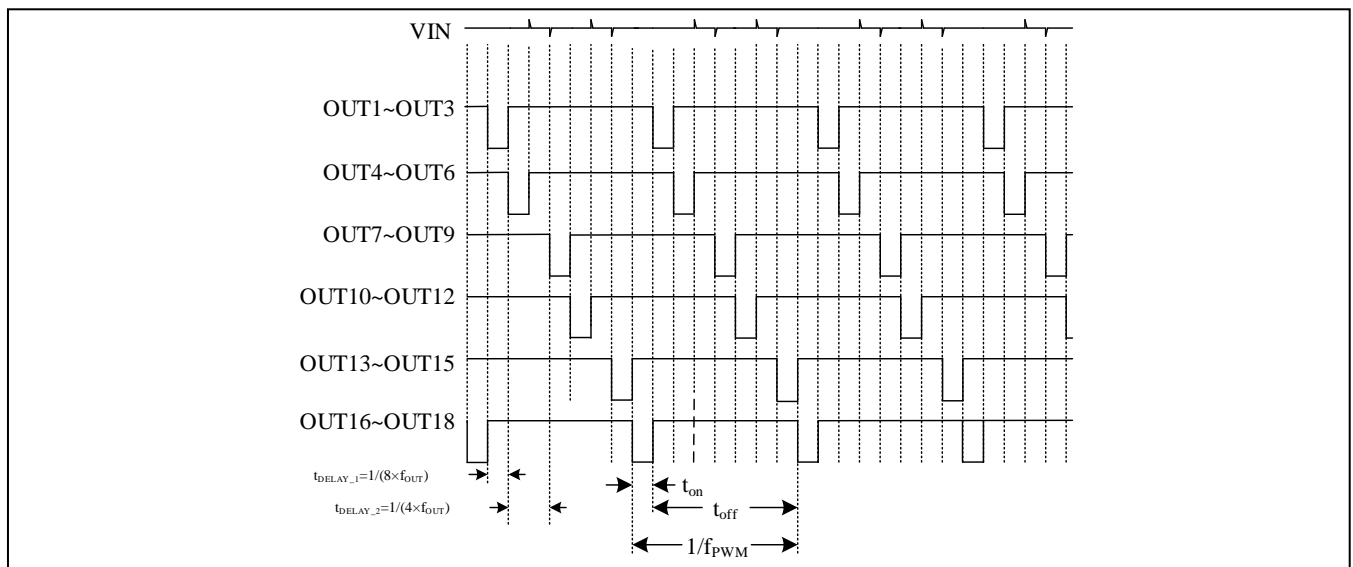

Figure 9 PWM Phase Delay Enabled

## 9.6 FAULT PROTECTION

### 9.6.1 FAULT REPORTING

For added system reliability, the IS32LT3138 integrates various fault detections for LED string open/short, single LED short, overcurrent (ISET shorted), over temperature, CRC error and watchdog timeout (fail-safe modes) conditions. The open drain pin FAULTB can be used for fault condition reporting. If any fault occurs, the corresponding bit in FLT\_TYPE register will be set to “1” and the FAULTB pin will go low after a delay time (programmed by FT[3:0] bits in FLT\_CONFIG register) to report fault condition. When it’s monitored by a host MCU, a pull-up resistor  $R_{FPU}$  (10k $\Omega$  recommended) from the FAULTB pin to the supply of the host MCU is required.

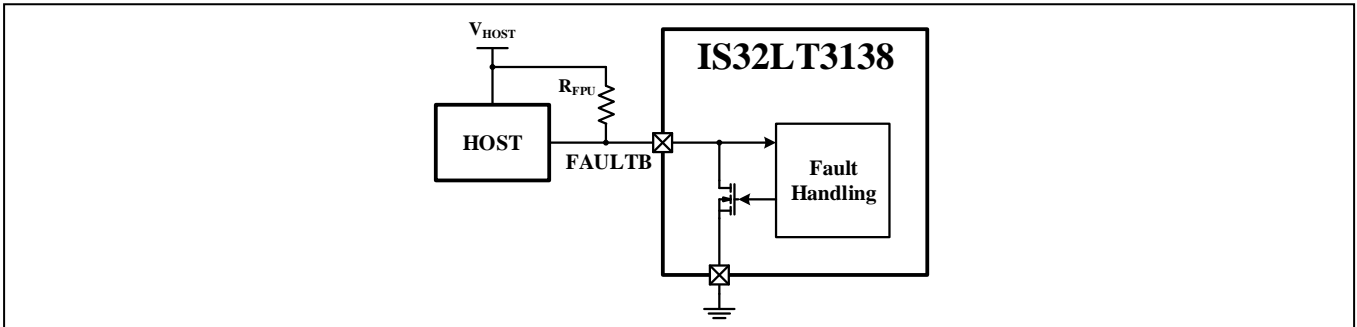

Figure 10 Host Monitors the Fault Reporting

### 9.6.2 LED STRING OPEN PROTECTION

The LED string open detection is enabled by setting the ODE and ODF bits in FLT\_DET\_EN register (4Ch) to “1”. If any LED string is opened, the corresponding OUTx pin voltage will be pulled down close to zero. When the OUTx pin voltage,  $V_{OUTx}$ , falls below the LED string open detection voltage,  $V_{OC\_FL}$  and persists for longer than a deglitch time (typical 10 $\mu$ s), the LED string open protection will be triggered. The corresponding fault flag bits in OPEN\_FLT register (51h & 52h & 53h) and the OPENF bit in FAULT\_TYPE register (57h) will be set to “1”. The FAULTB pin will go low after the delay time (programmed by FT[3:0] bits in FLT\_CONFIG register) to report the fault condition. The faulty channel will reserve a 4mA retry current for recovery detection.

No matter in which fault protection mode, the device will recover to normal operation and the FAULTB pin will go back to high impedance after the delay time (programmed by FT[3:0] bits in FLT\_CONFIG register) expires once the open condition is removed, i.e.  $V_{OUTx}$  rising above the LED string open detection voltage,  $V_{OC\_RS}$ . The corresponding fault flag bit in OPEN\_FLT register will reset to “0”. However, the OPENF bit in FAULT\_TYPE register (57h) is latched, which means that it cannot automatically reset to “0” after open condition being removed but must be cleared by the host MCU writing it back to “0”.

When PWM dimming is implemented, the LED string open detection is only enabled during the PWM ON phase. If the PWM on-time is less than the deglitch time (typical 10 $\mu$ s), the device does not report any LED string open fault.

### 9.6.3 LED STRING SHORT PROTECTION

The LED string short detection is enabled by setting the SDE and SDF bits in FLT\_DET\_EN register (4Ch) to “1”. If any LED string is short, the corresponding OUTx pin will be pulled up close to  $V_{IN}$ . When dropout voltage from the VIN pin to the OUTx pin,  $V_{IN}-V_{OUTx}$  (when SHORT\_FLT(4Bh) = “000”), rises above the LED string short detection voltage,  $V_{SC\_RS}$ , and persists for longer than a deglitch time (typical 10 $\mu$ s), the LED string short protection will be triggered. The corresponding fault flag bits in SHORT\_FLT register (4Eh & 4F & 50h) and the SHORTF bit in FAULT\_TYPE register (57h) will be set to “1”. The FAULTB pin will go low after the delay time (programmed by FT[3:0] bits in FLT\_CONFIG register) to report the fault condition. The faulty channel will reserve a 4mA retry current for recovery detection.

No matter in which fault protection mode, the device recovers to normal operation and the FAULTB pin will go back to high impedance after the delay time (programmed by FT[3:0] bits in FLT\_CONFIG register) once the short condition is removed,  $V_{OUTx}$  falling above the LED string short detection voltage,  $V_{SC\_FL}$ . The corresponding fault flag bit in SHORT\_FLT register will reset to “0”. However, the SHORTF bit in FAULT\_TYPE register (57h) is latched, which means that it cannot automatically reset to “0” after short condition being removed but must be cleared by the host MCU writing it back to “0”.

When PWM dimming is implemented, the LED string short detection is only enabled during PWM ON phase. If the PWM on-time is less than the deglitch time (typical 10 $\mu$ s), the device does not report any LED string short fault.

When the device is operated in DC mode, the PWM function is disabled. It is recommended to not enable both

LED string short and single LED short, because the IS32LT3138 may incorrectly report an LED string short as a single LED short. Individually enable either LED string short or single LED short detection. If a single LED short is reported, double check for LED string short or single LED short in software.

## 9.6.4 SINGLE LED SHORT PROTECTION

The single LED short detection is enabled by setting the SLSDE and SLSDF bits in FLT\_DET\_EN register (4Ch) to “1”. Then the single LED short detection is active after VIN voltage rising above the fault undervoltage-lockout voltage threshold  $V_{FLT\_UV}$ . That helps to prevent false fault detection due to the insufficient power supply voltage, such as power up transience. The single LED short detect threshold  $V_{SLSTH}$  of each channel is individually programmed by the corresponding LEDx\_SLS[4:0] bits in LEDx\_SLSTH registers (41h~49h). If single LED of any string is shorted, the corresponding OUTx pin voltage will rise. When the OUTx pin voltage,  $V_{OUTx}$ , rise above single LED short detect threshold,  $V_{SLSTH}$ , and persists for longer than a deglitch time (typical 10 $\mu$ s), the single LED short protection will be triggered. The corresponding fault flag bits in SLS\_FLT register (54h & 55h & 56h) and the SLS\_FLT bit in FAULT\_TYPE register (57h) will be set to “1”. The FAULTB pin will go low after the delay time (programmed by FT[3:0] bits in FLT\_CONFIG register) to report the fault condition. The faulty channel will reserve a 4mA retry current for recovery detection.

The device recovers to normal operation and the FAULTB pin will go back to high impedance after the delay time (programmed by FT[3:0] bits in FLT\_CONFIG register) once the single LED short condition is removed,  $V_{OUTx}$  rising above the LED string short detection voltage,  $V_{SLSTH}$ . The corresponding fault flag bit in SLS\_FLT register will reset to “0”. However, the SLSHORTF bit in FAULT\_TYPE register (57h) is latched, which means that it cannot automatically reset to “0” after single LED short condition being removed but must be cleared by the host MCU writing it back to “0”.

When PWM dimming is implemented, the single LED string short detection is only enabled during PWM ON phase. If the PWM on-time is less than the deglitch time (typical 10 $\mu$ s), the device does not report any single LED short fault.

## 9.6.5 OUTPUT OVERCURRENT (ISET PIN SHORT)

The device is protected from an output overcurrent condition caused by the  $R_{ISET}$  resistor. All output current is limited to 110mA (Typ.) in case of the ISET pin shorted to ground or too low value  $R_{ISET}$  resistor is connected to ISET pin. If the condition persists for longer than a deglitch time (typical 1 $\mu$ s), the ISET pin short protection will be triggered. All output current will be reduced to 17mA (Typ.). The RSET\_SH bit in FAULT\_TYPE register (57h) will be set to “1” and the FAULTB pin will go low after the delay time (programmed by FT[3:0] bits in FLT\_CONFIG register) to report the fault condition.

Once the resistance from the ISET pin to GND resumes to a normal range, all channels will recover to normal operation and the FAULTB pin will recover to high impedance after the delay time (programmed by FT[3:0] bits in FLT\_CONFIG register). However, the RSET\_SH bit in FAULT\_TYP register (57h) is latched, which means that it cannot automatically reset to “0” after ISET short condition being removed but must be cleared by the host MCU writing it back to “0”.

## 9.6.6 THERMAL SHUTDOWN

If the junction temperature exceeds  $T_{SD}$  (Typ. 168°C), all output channels will go to the OFF state and the TSD bit in FAULT\_TYPE register (57h) will be set to “1”. If the TRE bit in TEMP\_SEN register (02h) to “1”, the FAULTB pin will go low after the delay time (programmed by FT[3:0] bits in FLT\_CONFIG register) to report the fault condition. At this point, the device presumably begins to cool off. Any attempt to toggle the channels back to the source condition before the device has cooled to below ( $T_{SD}-T_{SD\_HYS}$ ) (Typ. 155°C) will be blocked and the device will not be allowed to restart. The FAULTB pin will recover to high impedance after the delay time (programmed by FT[3:0] bits in FLT\_CONFIG register) once the device cools down. However, the TSD bit in FAULT\_TYPE register (57h) is latched, which means that it cannot automatically reset to “0” but must be cleared by the host MCU writing it back to “0”.

## 9.6.7 THERMAL ROLL-OFF PROTECTION

The device integrates the thermal shutdown protection to prevent the device from overheating. In addition, to prevent the LEDs from flickering due to rapid thermal changes, the device also includes a programmable thermal roll-off feature to reduce power dissipation at high junction temperature.

The output current will be equal to the set value  $I_{OUTx}$  if the junction temperature of the device remains below thermal roll-off temperature threshold 140°C. If the junction temperature exceeds the temperature threshold, the output current of all channels will begin to linearly reduce following the junction temperature ramping up until thermal shutdown. The TF bit in FAULT\_TYPE register (57h) will be set to “1”. If the TRRE bit in TEMP\_SEN register (02h)

to “1”, the FAULTB pin will go low after the delay time (programmed by FT[3:0] bits in FLT\_CONFIG register) to report the fault condition. The percentage of the output current before thermal shutdown is programmable by the TROF[2:0] bits in the TEMP\_SEN register (02h).

The output current will linearly resume to the set value  $I_{OUTx}$  and the FAULTB pin will recover to high impedance after the delay time (programmed by FT[3:0] bits in FLT\_CONFIG register) once the junction temperature cools down below the thermal roll-off temperature threshold  $140^{\circ}\text{C}$ . However, the TF bit in FAULT\_TYPE register (57h) is latched, which means that it cannot automatically reset to “0” but must be cleared by the host MCU writing it back to “0”.

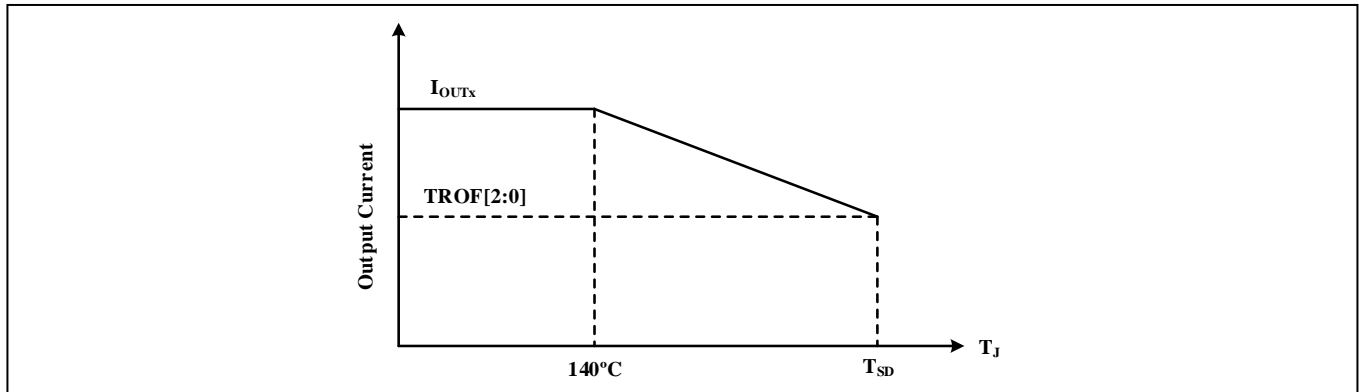

Figure 11 Thermal Roll-off Protection

By mounting the IS32LT3138 device on the same thermal substrate as the LEDs, use of this feature can also limit the dissipation of the LEDs.

### Fault Action Table (Both Normal State and Fail-Safe State):

Fault Type	Detection	Conditions	Actions	Fault Flags	FAULTB Pin	Recovery
Supply UVLO	$V_{IN} < V_{VIN\_UV}$ or $V_{DD} < V_{DD\_UV}$	-	Turn off all channels and reset all registers to default value	-	No action	$V_{IN} > (V_{VIN\_UV} + V_{VIN\_UVHY})$ or $V_{DD} > (V_{DD\_UV} + V_{DD\_UVHY})$
LED string open	$V_{IN} > V_{FLT\_UV}$ and $V_{OUTx} < V_{OC\_FL}$	PWM pulse width greater than $10\mu\text{s}$ (Typ.) and ODE = 1, ODF = 1	Faulty channel outputs 4mA and other channels on (ODF = 1)	OPEN_FLT and OPENF bit	Pull low	$V_{OUTx} > V_{OC\_RS}$ Write OPENF bit to “0”
LED string short	$(V_{IN} - V_{OUTx}) < V_{SC\_RS}$ (SHORT_FLT=000) or $V_{OUTx} > V_{SC}$ (SHORT_FLT≠000)	PWM pulse width greater than $10\mu\text{s}$ (Typ.) and SDE = 1, SDF = 1	Faulty channel outputs 4mA and other channels on (SDF = 1)	SHORT_FLT and SHORTF bit	Pull low	$(V_{IN} - V_{OUTx}) > V_{SC\_FL}$ (SHORT_FLT=000) or $V_{OUTx} < V_{SC}$ (SHORT_FLT≠000) Write SHORTF bit to “0”
Single LED short	$V_{IN} > V_{FLT\_UV}$ and $V_{OUTx} > V_{SLSTH}$	PWM pulse width greater than $10\mu\text{s}$ (Typ.) and SLSDE = 1, SLSDF = 1	Faulty channel outputs 4mA and other channels on (SLSDF = 1)	SLST_FLT and SLSHORTF bit	Pull low	$V_{OUTx} < V_{SLSTH}$ Write SLSHORTF bit to “0”
ISET pin short (Overcurrent)	$I_{OUTx}$ limited to 110mA (Typ.)	Longer than $1\mu\text{s}$ (Typ.) deglitch time	All channels reduced to 17mA (Typ.)	RSET_SH bit	Pull low	ISET pin to GND resistance resumes to normal range, Write RSET_SH bit to “0”
Thermal shutdown	$T_J > T_{SD}$	-	All channels off	TSD bit	Pull low (TRE = 1)	$T_J < (T_{SD} - T_{SD\_HYS})$ Write TSD bit to “0”
Thermal roll-off	$T_J > 140^{\circ}\text{C}$	TROF[2:0] ≠ 00	All channels linearly reduce output current	TF bit	Pull low (TRRE = 1)	$T_J < 140^{\circ}\text{C}$ Write TF bit to “0”
CRC error	Calculated CRC does not match CRC data	-	Increments CRC Error Count register	CRCF bit	Pull low	Write CRCF bit to “0”
Communication loss	Watchdog times out	$R_{FSMD} = 30\text{k}\Omega, 51\text{k}\Omega$ or $75\text{k}\Omega$ and no error-free communication	Enter fail-safe modes	CMWF bit	Pull low	Write CMWF bit to “0”

**Note 8:** OPENF, SHORTF, SLSHORTF, ISETSF, TSD, TF, CMWF and CRCF bits are latched. Even though the fault conditions are removed, they cannot automatically reset to “0” but must be cleared by the host MCU writing it back to “0”.

## 9.7 UART INTERFACES

The host MCU can communicate with the IS32LT3138 device using a Universal Asynchronous Receiver and Transmitter (UART). The UART communication process uses a command and response protocol (Lumibus protocol) mastered by the host MCU to write and read the registers to and from each IS32LT3138 device. The IS32LT3138 UART interface utilizes half-duplex communications (transmit and receive cannot overlap). A tri-state buffer in the IS32LT3138 drives the TX out pin, so it is recommended to place an external pull-up resistor on the RX input return line of the host MCU. An external pull-up on the MCU TX output will allow multiple IS32LT3138 devices to share a common pair of TX and RX signals by connecting all IS32LT3138 TX lines together and all IS32LT3138 RX lines together. The baud rate can support 100kbps~1Mbps.

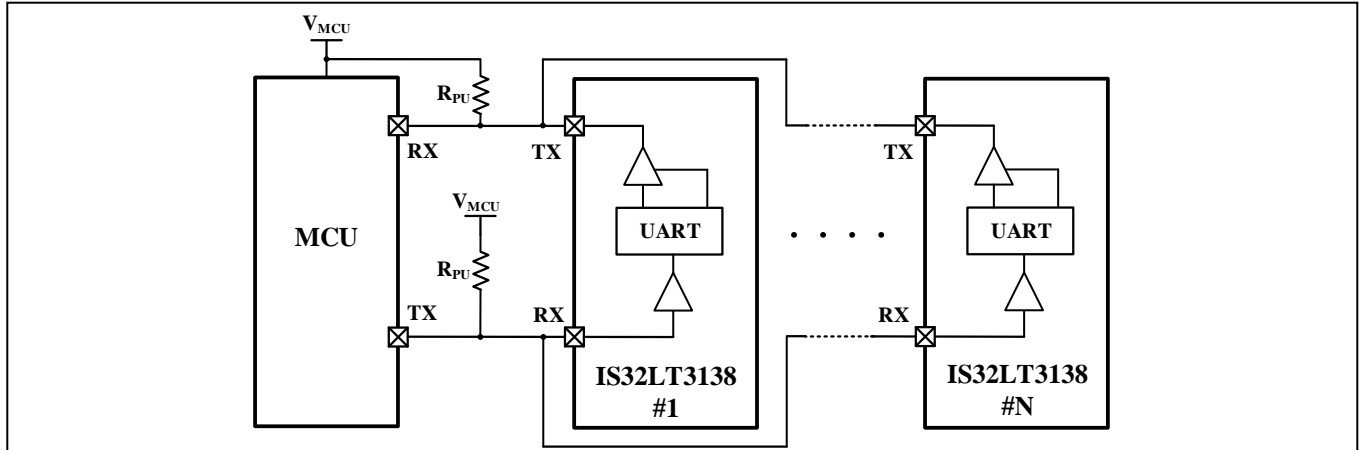

Figure 12 UART Interface Connection

Additionally, the physical TX and RX connections of IS32LT3138 can be joined together through a standard CAN transceiver (CAN PHY), as shown in Figure 13. This has the added advantage of protection from shorts to battery and/or shorts to ground on the cables and/or harnesses between the host MCU board and the IS32LT3138 board. The CAN physical layer has excellent EMI and EMS performance with long distance off-board connection.

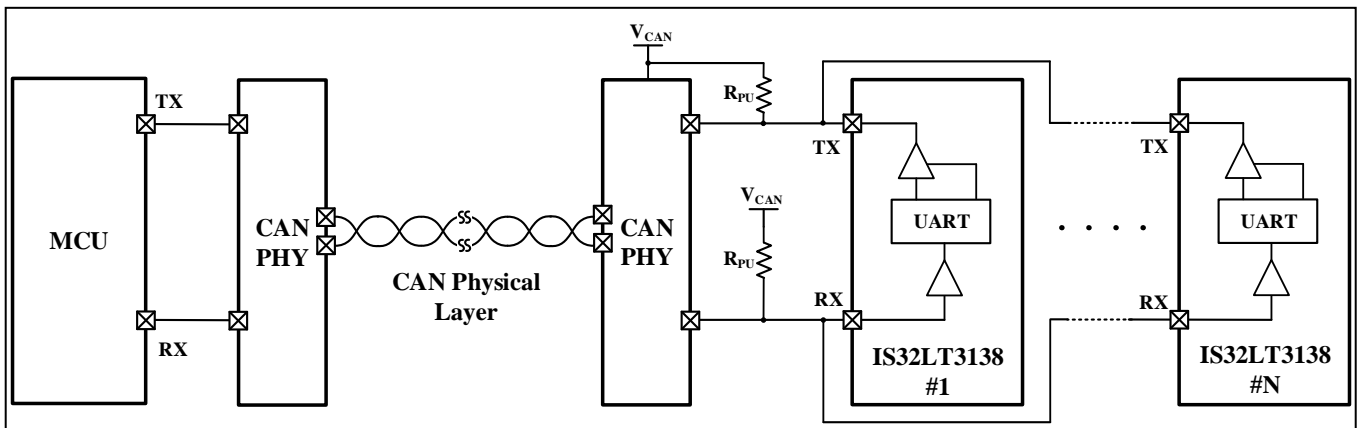

Figure 13 UART Interface with Standard CAN Transceiver Connection

### 9.7.1 UART DATA FORMAT

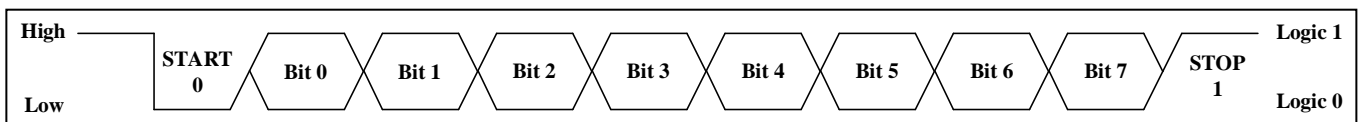

Figure 14 UART Data Byte Format

The UART operates with one start bit, eight data bits (LSbit first) and one stop bit. Above figure shows the waveform for an individual byte transfer on the UART. A logic “1” state occurs when the device drives the line to high voltage. A logic “0” state occurs when the device drives the line to ground. Below figure shows actual data bytes with UART data format.



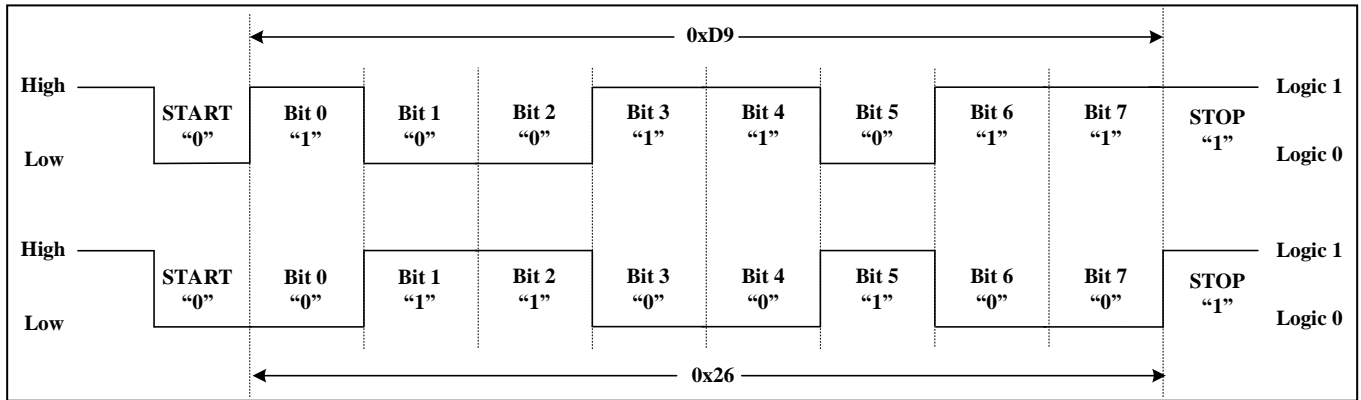

Figure 15 UART Data Transaction Example

The baud rate of UART communication can be 100kbps to 1Mbps which is synchronized by the baud rate of the SYNC byte of the BUS Reset command. The UART uses 32x over-sampling on the incoming asynchronous RX signal. Between UART data bytes, at least one bit is required as STOP bit.

## 9.7.2 LUMIBUS PROTOCOL

The communication uses the Lumibus protocol which is a UART-based protocol supported by most MCUs. The communication process of all three interfaces uses a command and response protocol mastered by the host MCU to write and read the registers to and from each IS32LT3138 device. This means that the IS32LT3138 device never initiates traffic onto the network. The Lumibus protocol maps the registers into an address space on each device. The host MCU uses the Lumibus protocol to initiate a communication transaction by sending a command frame. This command frame addresses either one IS32LT3138 device directly or broadcasts to all IS32LT3138 devices on the network. This addressing may cause a response frame to be sent back from the slave IS32LT3138 device depending on the command type of the command frame. There are four types of commands:

- 1) BUS Reset Command: resets the UART
- 2) Write Command: writes data from host MCU to specific IS32LT3138 device(s)
- 3) Read Command: reads data from specific IS32LT3138 device to host MCU
- 4) Special Command: specifies IS32LT3138 device(s) to implement specific function.

There is no response frame given following a broadcast write command frame. Therefore, only two types of response frames exist that an IS32LT3138 device sends back to the host MCU: Write Acknowledge (if enabled) and Read Response.

## 9.7.3 COMMAND FRAME TYPES

### 9.7.3.1 BUS Reset Command Frame

The host MCU can reset the device UART and Lumibus protocol state machine at any time by sending BUS Reset command. The BUS Reset command consists of reset signal and SYNC byte (0x55). The reset signal includes at 150µs~10ms break low and at 2µs~100µs logic high break delimiter. Upon receiving the bus reset signal, the Lumibus protocol state machine of all IS32LT3138 devices on the bus will be reset to a known-good state. The bus reset signal must be followed by a SYNC byte (0x55) send by desired baud rate (within 100kbps to 1Mbps) to synchronize the baud rate to all IS32LT3138 devices. The subsequent communication must use the identical baud rate. With this synchronization approach, the cost of an external crystal oscillator is saved. To avoid clock drift over time and ambient temperature, it's recommended to periodically send a BUS Reset Command to the IS32LT3138 devices.

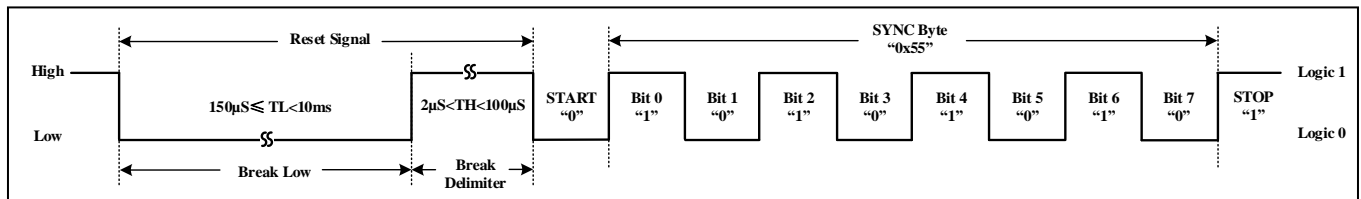
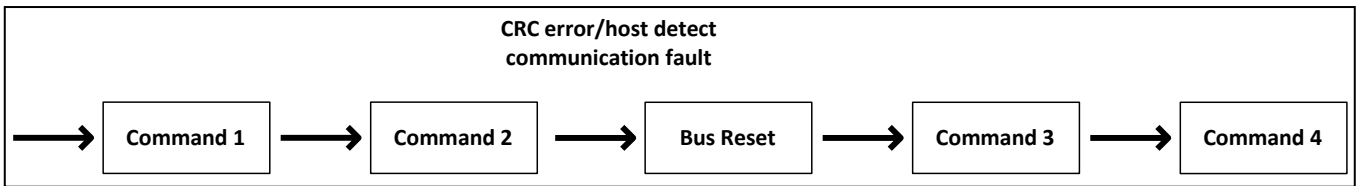

Figure 16 BUS Reset Command

Upon system power up, the host MCU must initialize the BUS by sending a BUS Reset Command before communication. This BUS reset operation can be optionally performed by the host MCU for several application

scenarios: (1) upon system power up, (2) communication watchdog times out, (3) communication fault is detected, illustrated as in the following diagram:



**Figure 17** Communication Fault is Detected

Note that the BUS Reset command only resets the interface state machine (including stored communication baud rate). It does not reset the registers and does not halt normal LED PWM operation.

**Note 9:** If TX or RX anyone disconnect, there will cause CRC error, communication again need send Bus reset.

### 9.7.3.2 Write Command Frame

The Write Command Frame is comprised of the following sequence.

CMD Frame Header (One Byte)	Device ID (One Byte)	Start Register Address (One Byte)	Data 1 (One Byte)	...	Data N (One Byte)	CRC_L (One Byte)	CRC_H (One Byte)
--------------------------------	-------------------------	--------------------------------------	----------------------	-----	----------------------	---------------------	---------------------

### 9.7.3.3 Acknowledge Frame

If the ACKEN bit is set in the SYSCFG register, the addressed device transmits an acknowledge back to the host MCU upon a successful single device write. The Acknowledge Frame is comprised of a single byte (ACK=0x7F) as the following sequence.

ACK (0x7F)
---------------

### 9.7.3.4 Read Command Frame (transferred by the host MCU)

The Read Command Frame is comprised of the following sequence.

CMD Frame Header (One Byte)	Device ID (One Byte)	Start Register Address (One Byte)	CRC_L (One Byte)	CRC_H (One Byte)
--------------------------------	-------------------------	--------------------------------------	---------------------	---------------------

A successfully-addressed IS32LT3138 device then transfers back the appropriate Read Response Frame.

The Read Response Frame is comprised of the following sequence.

RSP Frame Header (One Byte)	Device ID (One Byte)	Data 1 (One Byte)	...	Data N (One Byte)	CRC_L (One Byte)	CRC_H (One Byte)
--------------------------------	-------------------------	----------------------	-----	----------------------	---------------------	---------------------

### 9.7.3.5 Special Command Frame

The special command specifies the IS32LT3138 device to implement specific function which includes:

a) Update Command

This special command is used for below scenarios:

- Update the configuration of the PWM registers data and Scaling registers data into output stages at the next PWM boundary after this command is issued.
- Update the configuration of the DC\_PWM\_SEL register (00h).
- Update the configuration of the PHASE\_CTRL register (03h).

b) Registers Reset Command

Resets all registers to default value, excluding the PWR bit in SYSCFG register (4Ah).

The Special Command Frame is comprised of the following sequence:

CMD Frame Header (One Byte)	Device ID (One Byte)	CRC_L (One Byte)	CRC_H (One Byte)
--------------------------------	-------------------------	---------------------	---------------------

One complete command frame can be received successfully even if the bytes in the frame are not sent continuously. CRC error could be determined by reading back the written data byte.

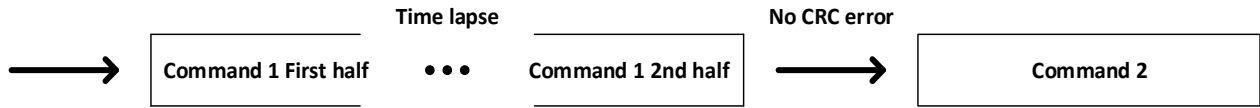

If host's watch dog time is disabled or time laps is within watchdog time

## 9.7.4 TRANSACTION FRAME DESCRIPTION

Command frames include the following byte types:

- 1) Frame Header Byte
- 2) Device ID Byte
- 3) Start Register Address Byte
- 4) N Data Byte(s) (N = 1~16, 32)
- 5) CRC Bytes (CRC\_L and CRC\_H)
- 6) Acknowledge Byte (ACK)

### 9.7.4.1 Frame Header Byte

The Frame Header Byte identifies the transaction as either a write/read command frame or a response frame. In addition, the Frame Header Byte indicates how many data bytes are being written/read or responded. The number of data bytes to be written/read or responded to can be 1~16 or 32.

Frame Header Type	D7	D6	D5	D4	D3	D2	D1	D0
CMD Frame Header	FRM_TYPE	W/R	BCON	CMD				
RSP Frame Header	FRM_TYPE	RSVD	RSVD	RSP				

The fields shown in the Frame Header Byte above are described in the table below.

	Value (BIN)	Description
FRM_TYPE (Bit 7)	0	Response frame sent back from the IS32LT3138 device to host MCU
	1	Command frame sent from host MCU to the IS32LT3138 device
W/R (Bit 6)	0	Write command frame
	1	Read command frame
BCON (Bit 5)	0	Single device write or read.
	1	Broadcast write. The Device ID Byte must be 0xBF to broadcast to all IS32LT3138 devices. Broadcast only accepts write command

	Value (BIN)	Description
CMD (Bit 4:0)	<b>Specify transmit data length for write/read command frame:</b>	
	00000 ~ 01111	1 byte ~ 16 bytes of data length
	10000	32 bytes of data length
	<b>For special commands (W/R bit must be set to "0"):</b>	
	11000	Update Command. Valid for both single device and broadcast write
	11110	Registers Reset Command. Valid for both single device and broadcast write
RSP (Bit 4:0)	<b>Specify transmit data length for response frame:</b>	
	00000 ~ 01111	1 byte ~ 16 bytes of data length
	10000	32 bytes of data length

#### 9.7.4.2 Device ID Byte

	D7	D6	D5	D4	D3	D2	D1	D0
Device ID	p[1]	p[0]	DEV_ID [5:0]					

There are six DEV\_ID bits and two parity bits.

The parity bits for the Device ID byte are calculated with the equations below:

$$p[1] = \sim(\text{dev\_id}[1] \wedge \text{dev\_id}[3] \wedge \text{dev\_id}[4] \wedge \text{dev\_id}[5])$$

$$p[0] = \text{dev\_id}[0] \wedge \text{dev\_id}[1] \wedge \text{dev\_id}[2] \wedge \text{dev\_id}[4]$$

The device ID of each IS32LT3138 device is determined by the resistors connected from three address pins of ADDR0, ADDR1 and ADDR2 to GND. As following mapping for the Device ID byte. For a broadcast command of UART interface, the DEV\_ID[5:0] must be 0b 111111, otherwise the broadcast command will be invalid.

R <sub>AD2</sub>	R <sub>AD1</sub>	R <sub>AD0</sub>	D7	D6	D5	D4	D3	D2	D1	D0	DEVICE ID (HEX)
(kΩ, Note 10)											
10k	10k	10k	1	0	0	0	0	0	0	0	80
10k	10k	30k	0	1	0	1	0	0	0	0	50
10k	10k	51k	0	0	1	0	0	0	0	0	20
10k	10k	75k	1	1	1	1	0	0	0	0	F0
10k	30k	10k	1	1	0	0	0	1	0	0	C4
10k	30k	30k	0	0	0	1	0	1	0	0	14
10k	30k	51k	0	1	1	0	0	1	0	0	64
10k	30k	75k	1	0	1	1	0	1	0	0	B4
10k	51k	10k	0	0	0	0	1	0	0	0	08
10k	51k	30k	1	1	0	1	1	0	0	0	D8
10k	51k	51k	1	0	1	0	1	0	0	0	A8
10k	51k	75k	0	1	1	1	1	0	0	0	78
10k	75k	10k	0	1	0	0	1	1	0	0	4C
10k	75k	30k	1	0	0	1	1	1	0	0	9C
10k	75k	51k	1	1	1	0	1	1	0	0	EC
10k	75k	75k	0	0	1	1	1	1	0	0	3C
30k	10k	10k	1	1	0	0	0	0	0	1	C1
30k	10k	30k	0	0	0	1	0	0	0	1	11
30k	10k	51k	0	1	1	0	0	0	0	1	61
30k	10k	75k	1	0	1	1	0	0	0	1	B1

# IS32LT3138



30k	30k	10k	1	0	0	0	0	1	0	1	85
30k	30k	30k	0	1	0	1	0	1	0	1	55
30k	30k	51k	0	0	1	0	0	1	0	1	25
30k	30k	75k	1	1	1	1	0	1	0	1	F5
30k	51k	10k	0	1	0	0	1	0	0	1	49
30k	51k	30k	1	0	0	1	1	0	0	1	99
30k	51k	51k	1	1	1	0	1	0	0	1	E9
30k	51k	75k	0	0	1	1	1	0	0	1	39
30k	75k	10k	0	0	0	0	1	1	0	1	0D
30k	75k	30k	1	1	0	1	1	1	0	1	DD
30k	75k	51k	1	0	1	0	1	1	0	1	AD
30k	75k	75k	0	1	1	1	1	1	0	1	7D
51k	10k	10k	0	1	0	0	0	0	1	0	42
51k	10k	30k	1	0	0	1	0	0	1	0	92
51k	10k	51k	1	1	1	0	0	0	1	0	E2
51k	10k	75k	0	0	1	1	0	0	1	0	32
51k	30k	10k	0	0	0	0	0	1	1	0	06
51k	30k	30k	1	1	0	1	0	1	1	0	D6
51k	30k	51k	1	0	1	0	0	1	1	0	A6
51k	30k	75k	0	1	1	1	0	1	1	0	76
51k	51k	10k	1	1	0	0	1	0	1	0	CA
51k	51k	30k	0	0	0	1	1	0	1	0	1A
51k	51k	51k	0	1	1	0	1	0	1	0	6A
51k	51k	75k	1	0	1	1	1	0	1	0	BA
51k	75k	10k	1	0	0	0	1	1	1	0	8E
51k	75k	30k	0	1	0	1	1	1	1	0	5E
51k	75k	51k	0	0	1	0	1	1	1	0	2E
51k	75k	75k	1	1	1	1	1	1	1	0	FE
75k	10k	10k	0	0	0	0	0	0	1	1	03
75k	10k	30k	1	1	0	1	0	0	1	1	D3
75k	10k	51k	1	0	1	0	0	0	1	1	A3
75k	10k	75k	0	1	1	1	0	0	1	1	73
75k	30k	10k	0	1	0	0	0	1	1	1	47
75k	30k	30k	1	0	0	1	0	1	1	1	97
75k	30k	51k	1	1	1	0	0	1	1	1	E7
75k	30k	75k	0	0	1	1	0	1	1	1	37
75k	51k	10k	1	0	0	0	1	0	1	1	8B
75k	51k	30k	0	1	0	1	1	0	1	1	5B
75k	51k	51k	0	0	1	0	1	0	1	1	2B
75k	51k	75k	1	1	1	1	1	0	1	1	FB
75k	75k	10k	1	1	0	0	1	1	1	1	CF
75k	75k	30k	0	0	0	1	1	1	1	1	1F
75k	75k	51k	0	1	1	0	1	1	1	1	6F
75k	75k	75k	1	0	1	1	1	1	1	1	BF
-	-	-	1	0	1	1	1	1	1	1	BF (Note 11) (for broadcast command only)

**Note 10:** The tolerance range of resistance accuracy could be  $\pm 1\%$  or  $\pm 5\%$  for 10k $\Omega$ , 30k $\Omega$ , and 75k $\Omega$ , but the tolerance range of resistance accuracy should be  $\pm 1\%$  for 51k $\Omega$ .

**Note 11:** The Device ID Byte must be 0xBF to broadcast to all IS32LT3138 devices. Broadcast only accepts write command.

**Note 12:** After IS32LT3138 powers on, it is suggested to wait for 3ms before sending a command, as the IS32LT3138 requires 3ms to detect its Device ID upon power-up.

### 9.7.4.3 Start Register Address Byte

The Lumibus protocol allows up to 32 successive register locations from the addressed register to be written or read by a single command frame. The Start Register Address Byte is a single byte which specifies the first register being written or read. The Start Register Address byte is present only in Write and Read Command transactions, not in Read Response and Special command transactions.

### 9.7.4.4 N Data Byte (s)

The Frame Header Byte specifies the number of data bytes to be included in the frame.

### 9.7.4.5 CRC Bytes (CRC\_L and CRC\_H)

The host MCU sends command to IS32LT3138 using CRC-16-IBM standard for CRC checksum calculation, which will cover the whole frame bytes, e.g., Frame Header Byte, Device ID Byte, Start Register Address Byte, N Data Bytes. Lower byte first followed by higher byte. The CRC Bytes allow detection of errors within the transaction frame. The device increments the CRC Error Count Register (59h) each time a CRC error occurs on an incoming command frame and the CRCF bit in FLT\_TYPE register (57H) will be set to “1” and the FAULTB pin will go low to report fault condition after the delay time (programmed by FT[3:0] bits in FLT\_CONFIG register).

The CRCF bit in FLT\_TYPE register (57H) is latched, which means that it cannot automatically reset to “0” when no CRC error occurs but must be cleared by the host MCU writing it back to “0”. Once the CRCF bit is cleared, the FAULTB pin will go back to high impedance after the delay time (programmed by FT[3:0] bits in FLT\_CONFIG register).

The CRC bytes are also calculated by the addressed device during its Read Response. The CRC bytes are then appended to the end of the read data, lower byte first followed by higher byte. This allows the host MCU to check the read data coming from the IS32LT3138 device for any transmission errors. The following is a reference CRC checksum C code for a transmission to the IS32LT3138 devices.

```

UInt16 crc_16_ibm (UInt8 *buf, UInt8 len)
{
    UInt16 crc = 0;
    UInt16 l;
    while (len--)
    {
        crc ^= *buf++;
        for (l = 0; l < 8; l++){
            crc = (crc >> 1) ^ ((crc & 1) ? 0xa001 : 0);
        }
    }
    return crc;
}
    
```

Upon reading data from the IS32LT3138 device, the host MCU should calculate and compare the CRC to determine whether valid data was received. When IS32LT3138 sends back CRC bytes to the host MCU, the calculated CRC bytes must be bit-reversed before comparison to the received CRC bytes. The following is a reference code to perform received CRC bit reversal.

```

UInt8 reverse_byte(UInt8 byte)
{
    // First, swap the nibbles
    byte = (((byte & 0xF0) >> 4) | ((byte & 0x0F) << 4));
    // Then, swap bit pairs
    byte = (((byte & 0xCC) >> 2) | ((byte & 0x33) << 2));
    // Finally, swap adjacent bits
    byte = (((byte & 0xAA) >> 1) | ((byte & 0x55) << 1));
    // We should now be reversed (bit 0 <--> bit 7, bit 1 <--> bit 6, etc.)
    return byte;
}
    
```

```

}

```

The following is a reference code for checking the read data against received CRC bytes.

```

bool is_crc_valid(Uint8 *rx_buf, Uint8 crc_start)
{
    Uint16 crc_calc; // Calculated CRC
    Uint8  crc_msb, crc_lsb; // Individual bytes of calculated CRC
    // Calculate the CRC based on bytes received
    crc_calc = crc_16_ibm(rx_buf, crc_start);
    crc_lsb = (crc_calc & 0x00FF);
    crc_msb = ((crc_calc >> 8) & 0x00FF);
    // Perform the bit reversal within each byte
    crc_msb = reverse_byte(crc_msb);
    crc_lsb = reverse_byte(crc_lsb);
    // Do they match?
    if((*rx_buf + crc_start) == crc_lsb) && (*(rx_buf + crc_start + 1) == crc_msb)
    {
        return TRUE;
    }
    else
    {
        return FALSE;
    }
}

```

#### 9.7.4.6 Acknowledge Byte

The Acknowledge Byte (“ACK”) consists of a single byte (ACK=0x7F):

ACK is sent back by the addressed IS32LT3138 device only if the ACKEN bit is set in the SYSCFG register (4Ah) and only if the write is successful. A successful write yields no CRC checksum error or parity errors. Note that the acknowledge is only valid for single device write transaction of IS32LT3138.

#### 9.7.4.7 Turnaround Time

When considering back-to-back data transfer, the turnaround time (additional time required between the end of the previous byte stop bit and the beginning of the next byte start bit) is required, that means a finite amount of dead time must be inserted between two bytes or two command frames. It’s recommended to use dual stop bits mode for the UART interface.

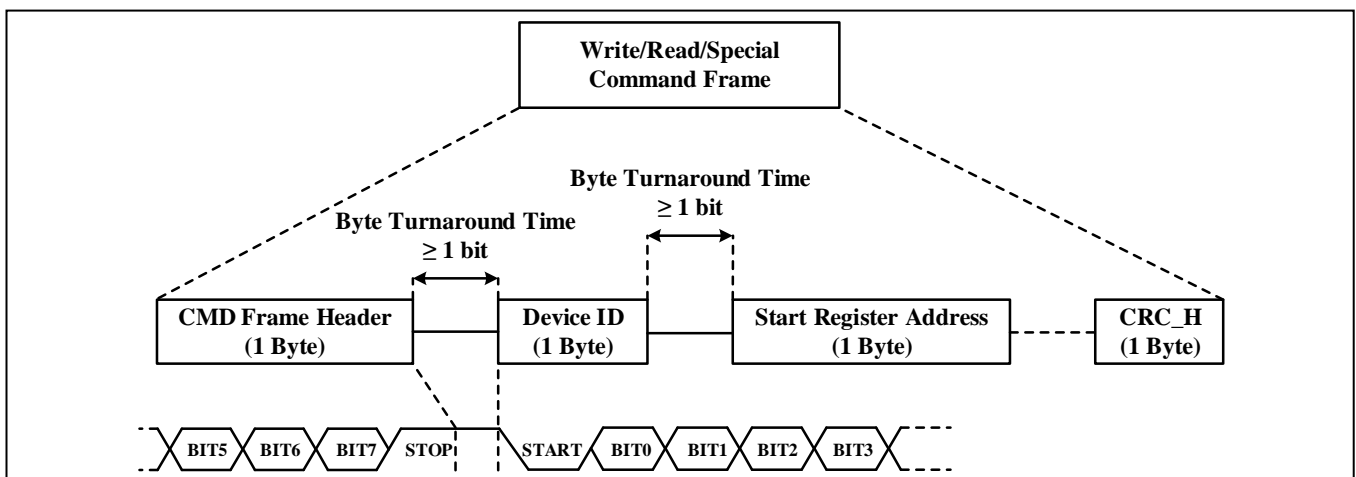

Figure 18 Turnaround Time Between Byte to Byte

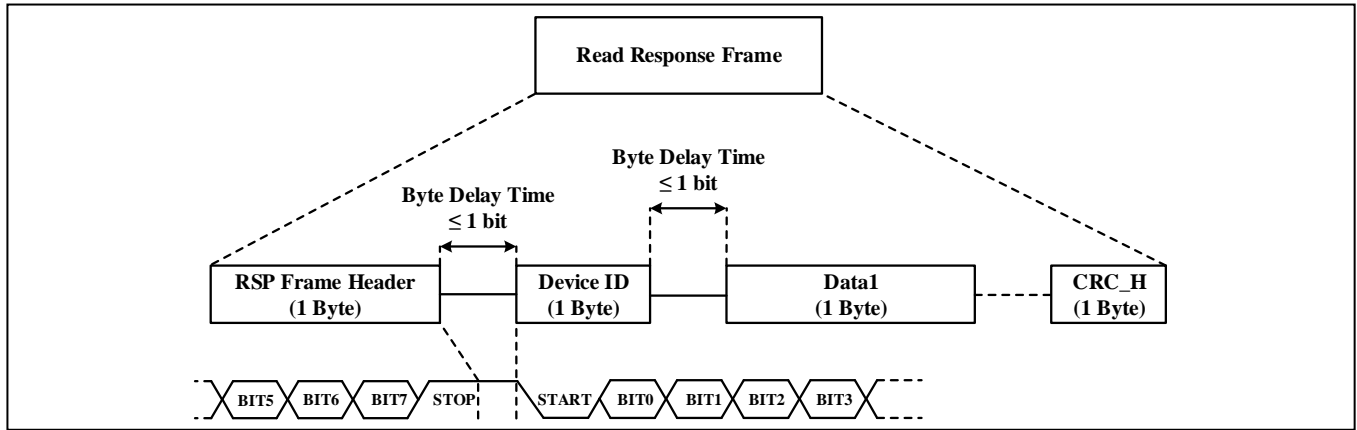

Figure 19 Delay Time Between Byte to Byte of Read Response Frame

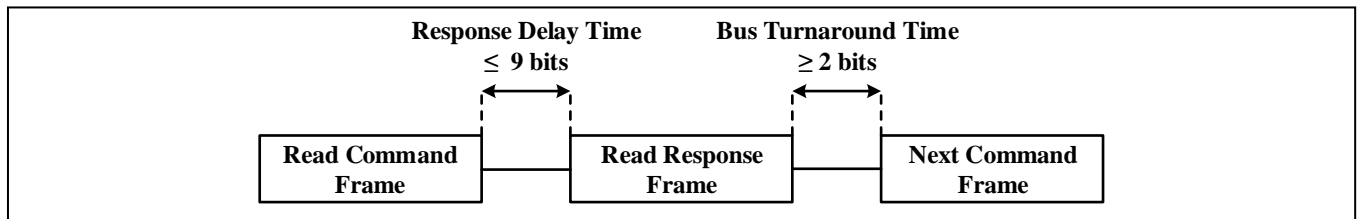

Figure 20 Turnaround Time Between Read Response Frame to Next Command Frame

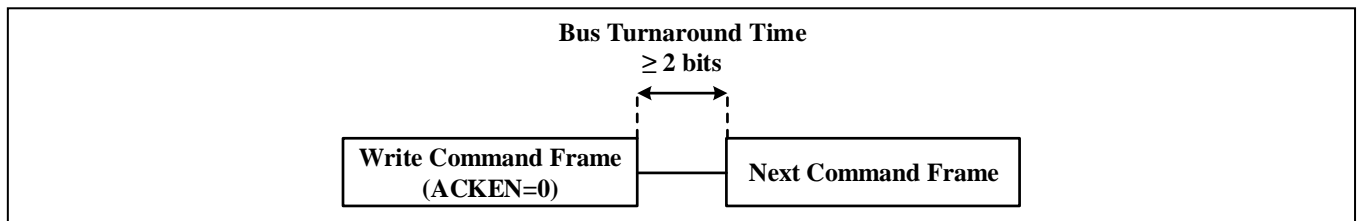

Figure 21 Turnaround Time Between Write Command Frame to Next Command Frame (ACK Disabled)

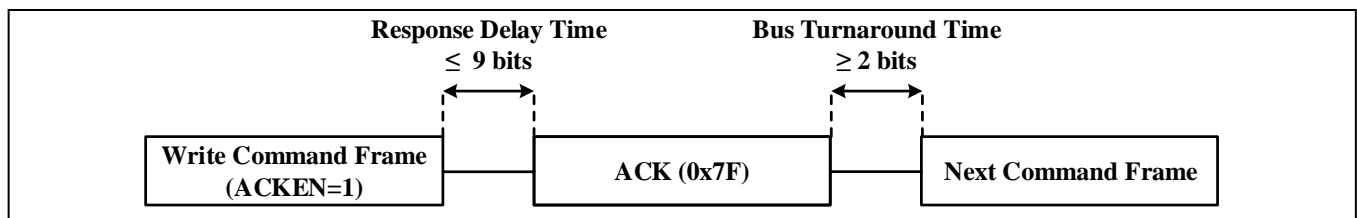

Figure 22 Turnaround Time Between ACK to Next Command Frame (ACK Enabled)

**9.8 COMMUNICATIONS EXAMPLES**

The total number of transmitted bytes depends on the specific task being performed. The examples below show the sequence of transmitted bytes for a given transaction.

**9.8.1 Example 1: Single Device Write of 3 Bytes**

Write to Device ID with parity = 0x55, R<sub>AD0</sub>=30kΩ, R<sub>AD1</sub>=30kΩ, R<sub>AD2</sub>=30kΩ: beginning at register 26h, PWM1\_H=0x1F, PWM2\_H=0x2F, PWM1\_2\_L=0x3F

Byte Types	Number of Bytes
CMD Frame Header Byte	1
Device ID Byte	1
Start Register Address Byte	1
Data Bytes	3
CRC Bytes	2
Total	8



Command Frame								
Interface	CMD Frame Header	Device ID	Start Register Address	Data 1	Data 2	Data 3	CRC_L	CRC_H
UART	0x82 (0b10000010)	0x55	0x26	0x1F	0x2F	0x3F	0x74	0x80

Acknowledge from addressed device (if enabled ACKEN bit for IS32LT3138)

Acknowledge Frame	
ACK	
0x7F	

### 9.8.2 Example 2: Single Device Read of 2 Bytes

Read from Device ID with parity = 0xA3, R<sub>AD0</sub>=51kΩ, R<sub>AD1</sub>=10kΩ, R<sub>AD2</sub>=75kΩ: beginning at register 57H, read FLT\_TYPE

Byte Types	Number of Bytes
CMD Frame Header Byte	1
Device ID Byte	1
Start Register Address Byte	1
CRC Bytes	2
Total	5

Command Frame					
Interface	CMD Frame Header	Device ID	Start Register Address	CRC_L	CRC_H
UART	0xC1 (0b11000001)	0xA3	0x57	0x68	0xF2

Read Response: FLT\_TYPE=0x00

Byte Types	Number of Bytes
RSP Frame Header Byte	1
Device ID Byte	1
Data Bytes	2
CRC Bytes	2
Total	6

Command Frame						
Interface	RSP Frame Header	Device ID	Data 1	Data 2	CRC_L	CRC_H
UART	0x01 (0b00000001)	0xA3	0x00	0x00	0x8F	0x7B

### 9.8.3 Example 3: Broadcast Write of 3 Bytes

Broadcast write to all devices (fixed Device ID with parity = 0xBF): beginning at register 14h, SCA1=0x0F,

SCA2=0x1F, SCA3=0x2F.

Byte Types	Number of Bytes
CMD Frame Header Byte	1
Device ID Byte	1
Start Register Address Byte	1
Data Bytes	3
CRC Bytes	2
Total	8

Command Frame								
Interface	CMD Frame Header	Device ID	Start Register Address	Data 1	Data 2	Data 3	CRC_L	CRC_H
UART	0xA2 (0b10100010)	0xBF	0x14	0x0F	0x1F	0x2F	0x70	0x86

#### 9.8.4 Example 4: Broadcast Registers Reset Command (Special Command)

Broadcast Registers Reset Command to all devices (fixed Device ID with parity = 0xBF):

Byte Types	Number of Bytes
CMD Frame Header Byte	1
Device ID Byte	1
CRC Bytes	2
Total	4

Command Frame				
Interface	CMD Frame Header	Device ID	CRC_L	CRC_H
UART	0xBE (0b10111110)	0xBF	0x30	0x10

#### 9.8.5 Example 5: Broadcast Update Command (Special Command)

Broadcast Update Command to all devices (fixed Device ID with parity = 0xBF):

Byte Types	Number of Bytes
CMD Frame Header Byte	1
Device ID Byte	1
CRC Bytes	2
Total	4

Command Frame				
Interface	CMD Frame Header	Device ID	CRC_L	CRC_H
UART	0xB8 (0b10111000)	0xBF	0x33	0xB0

## 9.9 DEVICE FUNCTIONAL MODES

The IS32LT3138 device operates in one of several states.

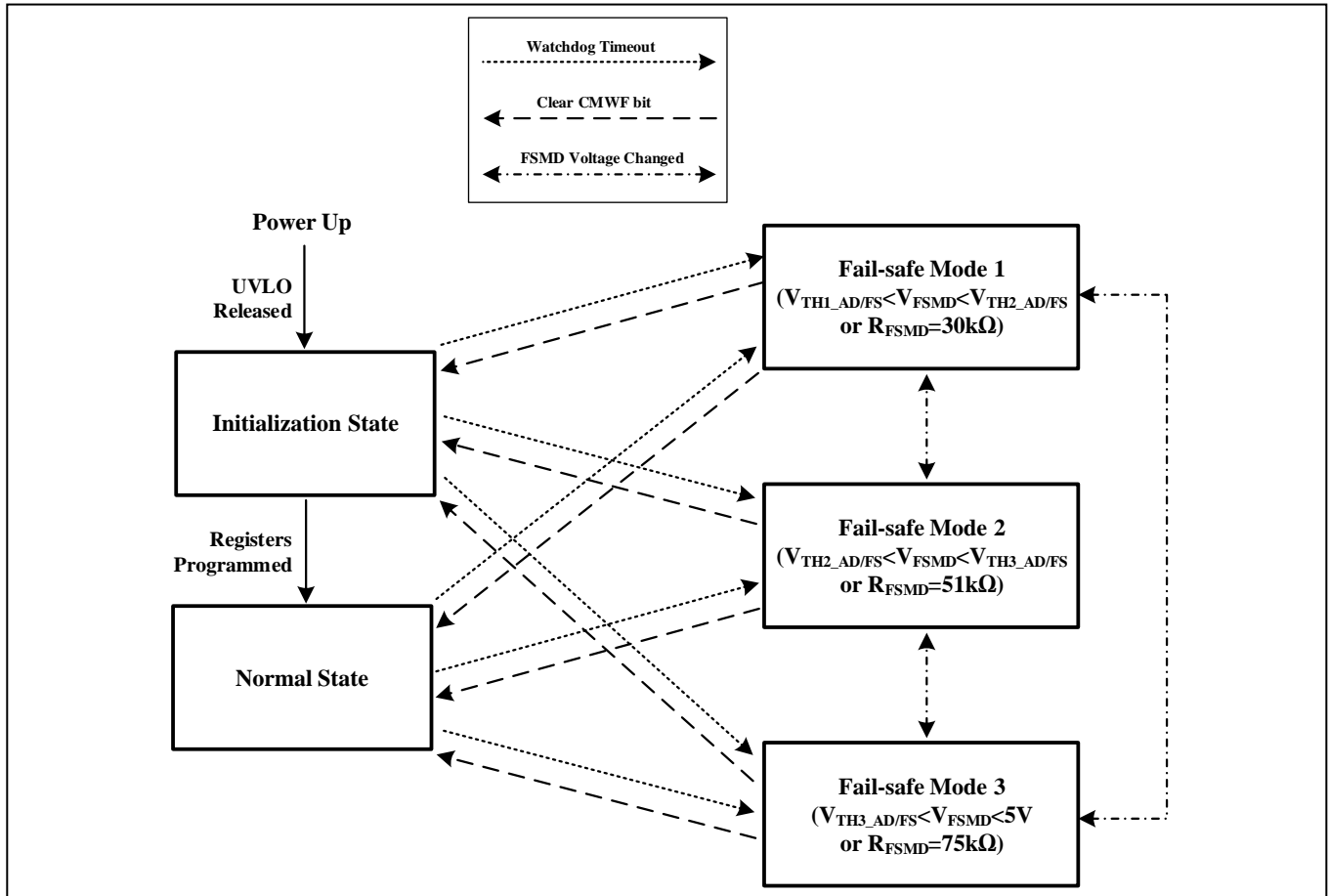

Figure 23 Operation States

### 9.9.1 INITIALIZATION STATE

On power up and once released from UVLO, the device enters an initialization state. In this state, all registers are reset to default values and all outputs are in off state. The device waits to receive commands from the MCU master.

### 9.9.2 NORMAL STATE

In normal state, the IS32LT3138 registers control its outputs by accepting interface commands and by monitoring and responding to realtime events on the inputs associated with the analog and power circuitry. This allows dimming of the LED outputs using the registers settings.

### 9.9.3 FAIL-SAFE STATE

This state allows the user to preset the outputs' state if the communication is broken. The device integrates a communication watchdog timer that operates based on the system clock pulse. The tap point, programmed via CMWTAP register (4Ah), defines the timing of the communication watchdog timer (a 24-bit/25-bit counter). By default, the tap point is set to bit 22, which means the device requires  $2^{22}$  (or  $2^{21}$ ) system clock cycles for the communication watchdog timer to time out. If the communication watchdog times out (no error-free communication is successfully received for the programmed number of system clock cycles), the device will enter fail-safe mode which includes three modes, Mode 1 ~ Mode 3.

The FSMD pin is used to configure the fail-safe modes. When the resistor  $R_{FSMD}$  is connected from the FSMD pin to ground, the internal  $I_{AD/FS}$  (typical  $50\mu A$ ) current source creates a voltage on the FSMD pin,  $V_{FSMD}$ . The device compares the  $V_{FSMD}$  with internal different reference voltage levels ( $V_{TH1\_AD/FS}$ ,  $V_{TH2\_AD/FS}$  and  $V_{TH3\_AD/FS}$ ) to determine the fail-safe mode. It also allows to externally apply proper voltage on the FSMD pin to either choose or change the fail-safe mode. Refer to the Fail-safe Mode Setting Table.

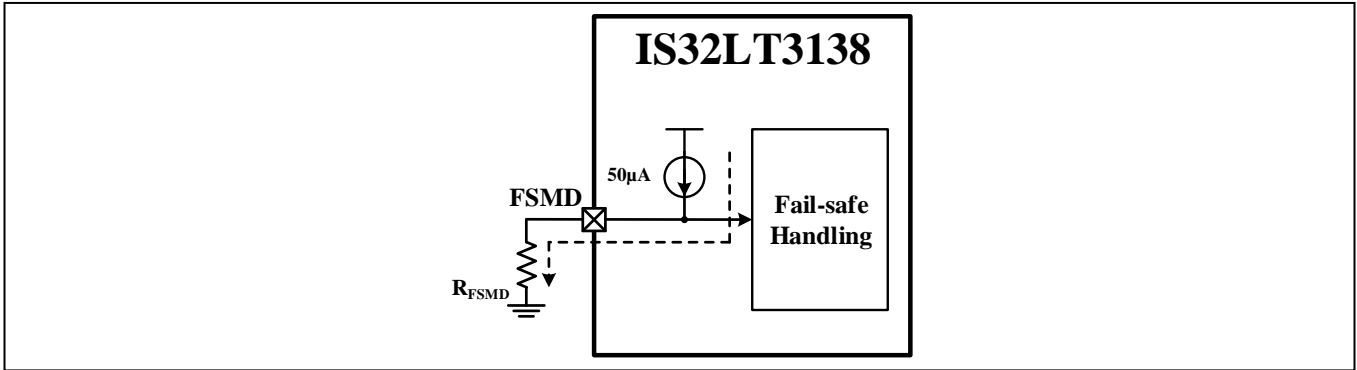

**Figure 24** Fail-safe Mode Setting

When  $0V < V_{FSMD} < V_{TH1\_AD/FS}$ , or  $R_{FSMD} = 10k\Omega$ , the internal communication watchdog is invalid, and the fail-safe mode is disabled. The outputs are always controlled by the scaling and PWM registers (14h~40h).

When  $V_{TH1\_AD/FS} < V_{FSMD} < V_{TH2\_AD/FS}$ , or  $R_{FSMD} = 30k\Omega$ , the internal communication watchdog is active, and the fail-safe mode is Mode 1. If the watchdog times out, the device will enter fail-safe Mode 1 and the outputs will be determined by the DEFAULT registers (07h~13h). The CMWF bit in FLT\_TYPE register (57H) will be set to “1” and the FAULTB pin will go low after the delay time (programmed by FT[3:0] bits in FLT\_CONFIG register) to report the fault condition. To quit from the fail-safe mode to normal state, the CMWF bit in FLT\_TYPE register (57H) must be cleared by the host MCU writing it to “0”. The watchdog timer will be reset and the FAULTB pin will go back to high impedance after the delay time (programmed by FT[3:0] bits in FLT\_CONFIG register).

When  $V_{TH2\_AD/FS} < V_{FSMD} < V_{TH3\_AD/FS}$ , or  $R_{FSMD} = 51k\Omega$ , the internal communication watchdog is active, and the fail-safe mode is Mode 2. If the watchdog times out, the device will enter fail-safe Mode 2 and all outputs will be forced into completely off. The CMWF bit in FLT\_TYPE register (57H) will be set to “1” and the FAULTB pin will go low after the delay time (programmed by FT[3:0] bits in FLT\_CONFIG register) to report the fault condition. To quit from the fail-safe mode to normal state, the CMWF bit in FLT\_TYPE register (57H) must be cleared by the host MCU writing it to “0”. The watchdog timer will be reset and the FAULTB pin will go back to high impedance after the delay time (programmed by FT[3:0] bits in FLT\_CONFIG register).

When  $V_{TH3\_AD/FS} < V_{FSMD} < 5V$ , or  $R_{FSMD} = 75k\Omega$ , the internal communication watchdog is active, and the fail-safe mode is Mode 3. If the watchdog times out, the device will enter fail-safe Mode 3 and all outputs will be forced into fully on (with 98% PWM duty cycle). The CMWF bit in FLT\_TYPE register (57H) will be set to “1” and the FAULTB pin will go low after the delay time (programmed by FT[3:0] bits in FLT\_CONFIG register) to report the fault condition. To quit from the fail-safe mode to normal state, the CMWF bit in FLT\_TYPE register (57H) must be cleared by the host MCU writing it to “0”. The watchdog timer will be reset and the FAULTB pin will go back to high impedance after the delay time (programmed by FT[3:0] bits in FLT\_CONFIG register).

In the fail-safe modes, the fault protections also are valid, including LED string open/short, single LED short, overcurrent (ISET shorted), and over temperature.

Note that the device must be re-initialized after quitting from the fail-safe mode to normal state.

### 9.9.4 Fail-safe Mode Setting Table:

FSMD Pin	Fail-Safe Mode	LED State In Fail-Safe Mode
$0V < V_{FSMD} < V_{TH1\_AD/FS}$ or $R_{FSMD} = 10k\Omega$	Disabled	-
$V_{TH1\_AD/FS} < V_{FSMD} < V_{TH2\_AD/FS}$ or $R_{FSMD} = 30k\Omega$	Mode 1	Determined by Default Registers (07h~13h)
$V_{TH2\_AD/FS} < V_{FSMD} < V_{TH3\_AD/FS}$ or $R_{FSMD} = 51k\Omega$	Mode 2	All Completely Off
$V_{TH3\_AD/FS} < V_{FSMD} < 5V$ or $R_{FSMD} = 75k\Omega$	Mode 3	All On with 98% PWM duty cycle

## 10 REGISTER MAP

### 10.1 REGISTER MAP

ADDR HEX	REG NAME	D7	D6	D5	D4	D3	D2	D1	D0	R/W	DEFAULT	
00	CONFIG	-	-	PFS		CM	-	-	DC_PWM	R/W	0b 00000110	
01	GC_CTRL	-		GCC [5:0]						R/W	0b 00111111	
02	TEMP_SEN	TRE	TRRE	-	-	-	TROF [2:0]			R/W	0b 00000000	
03	PHASE_CTRL	-	-			-	-	-	PDE	R/W	0b 00000001	
07	DEFGCC	-	DEFDC_PWM	DEF_GCC[5:0]						R/W	0b 00000000	
08	DEFLED1	-	-	DEFLED[6:1]						R/W	0b 00000000	
09	DEFLED2	-	-	DEFLED[12:7]						R/W	0b 00000000	
0A	DEFLED3	-	-	DEFLED[18:13]						R/W	0b 00000000	
0B	DEFPWM1	PWM2[3:0]			PWM1[3:0]						R/W	0b 00000000
0C	DEFPWM2	PWM4[3:0]			PWM3[3:0]						R/W	0b 00000000
0D	DEFPWM3	PWM6[3:0]			PWM5[3:0]						R/W	0b 00000000
0E	DEFPWM4	PWM8[3:0]			PWM7[3:0]						R/W	0b 00000000
0F	DEFPWM5	PWM10[3:0]			PWM9[3:0]						R/W	0b 00000000
10	DEFPWM6	PWM12[3:0]			PWM11[3:0]						R/W	0b 00000000
11	DEFPWM7	PWM14[3:0]			PWM13[3:0]						R/W	0b 00000000
12	DEFPWM8	PWM16[3:0]			PWM15[3:0]						R/W	0b 00000000
13	DEFPWM9	PWM18[3:0]			PWM17[3:0]						R/W	0b 00000000
14	SCA1	-	SCA1_DATA [6:0]						R/W	0b 01111111		
15	SCA2	-	SCA2_DATA [6:0]						R/W	0b 01111111		
16	SCA3	-	SCA3_DATA [6:0]						R/W	0b 01111111		
17	SCA4	-	SCA4_DATA [6:0]						R/W	0b 01111111		
18	SCA5	-	SCA5_DATA [6:0]						R/W	0b 01111111		
19	SCA6	-	SCA6_DATA [6:0]						R/W	0b 01111111		
1A	SCA7	-	SCA7_DATA [6:0]						R/W	0b 01111111		
1B	SCA8	-	SCA8_DATA [6:0]						R/W	0b 01111111		
1C	SCA9	-	SCA9_DATA [6:0]						R/W	0b 01111111		
1D	SCA10	-	SCA10_DATA [6:0]						R/W	0b 01111111		
1E	SCA11	-	SCA11_DATA [6:0]						R/W	0b 01111111		
1F	SCA12	-	SCA12_DATA [6:0]						R/W	0b 01111111		
20	SCA13	-	SCA13_DATA [6:0]						R/W	0b 01111111		
21	SCA14	-	SCA14_DATA [6:0]						R/W	0b 01111111		
22	SCA15	-	SCA15_DATA [6:0]						R/W	0b 01111111		
23	SCA16	-	SCA16_DATA [6:0]						R/W	0b 01111111		
24	SCA17	-	SCA17_DATA [6:0]						R/W	0b 01111111		

25	SCA18	-	SCA18_DATA [6:0]		R/W	0b 01111111
26	PWM1_H	PWM1_DATA [11:4]			R/W	R/W
27	PWM2_H	PWM2_DATA [11:4]			R/W	0b 00000000
28	PWM1_2_L	PWM2_DATA [3:0]	PWM1_DATA [3:0]		R/W	0b 00000000
29	PWM3_H	PWM3_DATA [11:4]			R/W	0b 00000000
2A	PWM4_H	PWM4_DATA [11:4]			R/W	0b 00000000
2B	PWM3_4_L	PWM4_DATA [3:0]	PWM3_DATA [3:0]		R/W	0b 00000000
2C	PWM5_H	PWM5_DATA [11:4]			R/W	0b 00000000
2D	PWM6_H	PWM6_DATA [11:4]			R/W	0b 00000000
2E	PWM5_6_L	PWM6_DATA [3:0]	PWM5_DATA [3:0]		R/W	0b 00000000
2F	PWM7_H	PWM7_DATA [11:4]			R/W	0b 00000000
30	PWM8_H	PWM8DATA [11:4]			R/W	0b 00000000
31	PWM7_8_L	PWM8_DATA [3:0]	PWM7_DATA [3:0]		R/W	0b 00000000
32	PWM9_H	PWM9_DATA [11:4]			R/W	0b 00000000
33	PWM10_H	PWM10_DATA [11:4]			R/W	0b 00000000
34	PWM9_10_L	PWM10_DATA [3:0]	PWM9_DATA [3:0]		R/W	0b 00000000
35	PWM11_H	PWM11_DATA [11:4]			R/W	0b 00000000
36	PWM12_H	PWM12_DATA [11:4]			R/W	0b 00000000
37	PWM11_12_L	PWM12_DATA [3:0]	PWM11_DATA [3:0]		R/W	0b 00000000
38	PWM13_H	PWM13_DATA [11:4]			R/W	0b 00000000
39	PWM14_H	PWM14_DATA [11:4]			R/W	0b 00000000
3A	PWM13_14_L	PWM14_DATA [3:0]	PWM13_DATA [3:0]		R/W	0b 00000000
3B	PWM15_H	PWM15_DATA [11:4]			R/W	0b 00000000
3C	PWM16_H	PWM16_DATA [11:4]			R/W	0b 00000000
3D	PWM15_16_L	PWM16_DATA [3:0]	PWM15_DATA [3:0]		R/W	0b 00000000
3E	PWM17_H	PWM17_DATA [11:4]			R/W	0b 00000000
3F	PWM18_H	PWM18_DATA [11:4]			R/W	0b 00000000
40	PWM17_18_L	PWM18_DATA [3:0]	PWM17_DATA [3:0]		R/W	0b 00000000
41	LED1_2_SLS	LED2_SLSTH[3:0]	LED1_SLSTH [3:0]		R/W	0b 00000000
42	LED3_4_SLS	LED4_SLSTH[3:0]	LED3_SLSTH [3:0]		R/W	0b 00000000
43	LED5_6_SLS	LED6_SLSTH[3:0]	LED5_SLSTH [3:0]		R/W	0b 00000000
44	LED7_8_SLS	LED8_SLSTH[3:0]	LED7_SLSTH [3:0]		R/W	0b 00000000
45	LED9_10_SLS	LED10_SLSTH[3:0]	LED9_SLSTH [3:0]		R/W	0b 00000000
46	LED11_12_SLS	LED12_SLSTH[3:0]	LED11_SLSTH [3:0]		R/W	0b 00000000
47	LED13_14_SLS	LED14_SLSTH[3:0]	LED13_SLSTH [3:0]		R/W	0b 00000000
48	LED15_16_SLS	LED16_SLSTH[3:0]	LED15_SLSTH [3:0]		R/W	0b 00000000

# IS32LT3138

49	LED17_18_SLS	LED18_SLSTH[3:0]			LED17_SLSTH [3:0]				R/W	0b 00000000	
4A	SYSCFG	SSCEN	SSC [1:0]	ACKEN	CMWTAP [2:0]		PWR	R/W	0b 00001000		
4B	FS_FLTL	-	SHORT_FLT[2:0]		FLT_UV[3:0]				R/W	0b 00000100	
4C	FLT_DET_EN	-	-	SLSDF	SLSDE	SDF	SDE	ODF	ODE	R/W	0b 00001111
4D	FLT_CONFIG	-	SHCR	OPENCR	SLSHCR	FT[3:0]			R/W	0b 01100011	
4E	SHORT_FLT1	-	-	SHORT_FLT[6:1]				R	0b 00000000		
4F	SHORT_FLT2	-	-	SHORT_FLT[12:7]				R	0b 00000000		
50	SHORT_FLT3	-	-	SHORT_FLT[18:13]				R	0b 00000000		
51	OPEN_FLT1	-	-	OPEN_FLT[6:1]				R	0b 00000000		
52	OPEN_FLT2	-	-	OPEN_FLT[12:7]				R	0b 00000000		
53	OPEN_FLT3	-	-	OPEN_FLT[18:13]				R	0b 00000000		
54	SLS_FLT1	-	-	SLS_FLT[6:1]				R	0b 00000000		
55	SLS_FLT2	-	-	SLS_FLT[12:7]				R	0b 00000000		
56	SLS_FLT3	-	-	SLS_FLT[18:13]				R	0b 00000000		
57	FAULT_TYPE	TF	CRCF	RSET_SH	CMWF	TSD	SLSHOR TF	SHORT F	OPENF	R/W	0b 00000000
59	CERRCNT	CERRCNT [7:0]							R/W	0b 00000000	

**Note 13:** “RSVD” means “Reserved”. 04h~06h, 58h are not listed in the table, which is not recommended to operate.

## 10.2 REGISTERS DEFINITION

### 10.2.1 00h CONFIG Register

ADDR	REG NAME	D7:D6	D5:D4	D3	D2:D1	D0	DEFAULT
00h	CONFIG	-	PFS	CM	-	DC_PWM	0b 00000110

**PFS** PWM Frequency Setting  
 00 12bit, 244Hz  
 01 7+5bit, 24kHz  
 10/11 8bit, 24kHz

**CM** Current multiplier  
 0 Output current range of 33.3~100mA  
 1 Output current range is 1/3 of when CM= “0”

**DC\_PWM** DC or PWM output select for all outputs  
 0 PWM dimming. PWM duty cycle is determined by PWM registers 26h~40h  
 1 DC output. PWM dimming is disabled, and all outputs are DC current ( $I_{OUTx}$ )

### 10.2.2 01h GC\_CTRL Register

ADDR	REG NAME	D7:D6	D5:D0	DEFAULT
01h	GC_CTRL	-	GCC [5:0]	0b 00111111

GCC and SCAx control the  $I_{OUT}$  as shown in following formula:

$$I_{OUT\_F} = I_{OUT(MAX)} \times \frac{GCC}{64} \times \frac{SCAx}{128} \quad (5)$$

$$GCC = \sum_{n=0}^5 D[n] \cdot 2^n \quad (6)$$

$$SCAx = \sum_{n=0}^6 D[n] \cdot 2^n \quad (7)$$

## 10.2.3 02h TEMP\_SEN Register

ADDR	REG NAME	D7	D6	D5:D3	D2:D0	DEFAULT
02h	TEMP_SEN	TRE	TRRE	-	TROF [2:0]	0b 00000000

After adding analog dimming, the current of thermal roll off will not be a fixed proportion, and the slope of roll off can be calculated by formula.  $I_{ROLL} = I_{SET} \times (V_{ADJ} - V_x) / 2$ , ( $V_x$  is the optional voltage (TROF bits) of the register).

**TROF** Percentage of output current before thermal shutdown happens

000	0V
001	0.2V
010	0.4V
011	0.6V
100	0.8V
101	1.0V
110	1.2V
111	1.4V

**TRRE** Thermal Roll off Report Enable at FAULTB pin

0	Do not report
1	Report

**TRE** Thermal Shutdown Report Enable at FAULTB pin

0	Do not report
1	Report

## 10.2.4 03h PHASE\_CTRL Register

ADDR	REG NAME	D7:D1	D0	DEFAULT
03h	PHASE_CTRL	-	PDE	0b 00000001

**PDE** Phase delay enable

0	Disable
1	Enable (6 groups phase delay)

## 10.2.5 07h~13h Failsafe Program Register

ADDR	REG NAME	D7	D6	D5	D4	D3	D2	D1	D0	DEFAULT	
07h	DEFGCC	-	DEFDC_PWM	DEF_GCC[5:0]						0b 00000000	
08h	DEFLED1	-	-	DEFLED[6:1]						0b 00000000	
09h	DEFLED2	-	-	DEFLED[12:7]						0b 00000000	
0Ah	DEFLED3	-	-	DEFLED[18:13]						0b 00000000	
0Bh	DEFPWM1	PWM2[3:0]			PWM1[3:0]						0b 00000000
0Ch	DEFPWM2	PWM4[3:0]			PWM3[3:0]						0b 00000000
0Dh	DEFPWM3	PWM6[3:0]			PWM5[3:0]						0b 00000000
0Eh	DEFPWM4	PWM8[3:0]			PWM7[3:0]						0b 00000000
0Fh	DEFPWM5	PWM10[3:0]			PWM9[3:0]						0b 00000000
10h	DEFPWM6	PWM12[3:0]			PWM11[3:0]						0b 00000000
11h	DEFPWM7	PWM14[3:0]			PWM13[3:0]						0b 00000000
12h	DEFPWM8	PWM16[3:0]			PWM15[3:0]						0b 00000000
13h	DEFPWM9	PWM18[3:0]			PWM17[3:0]						0b 00000000



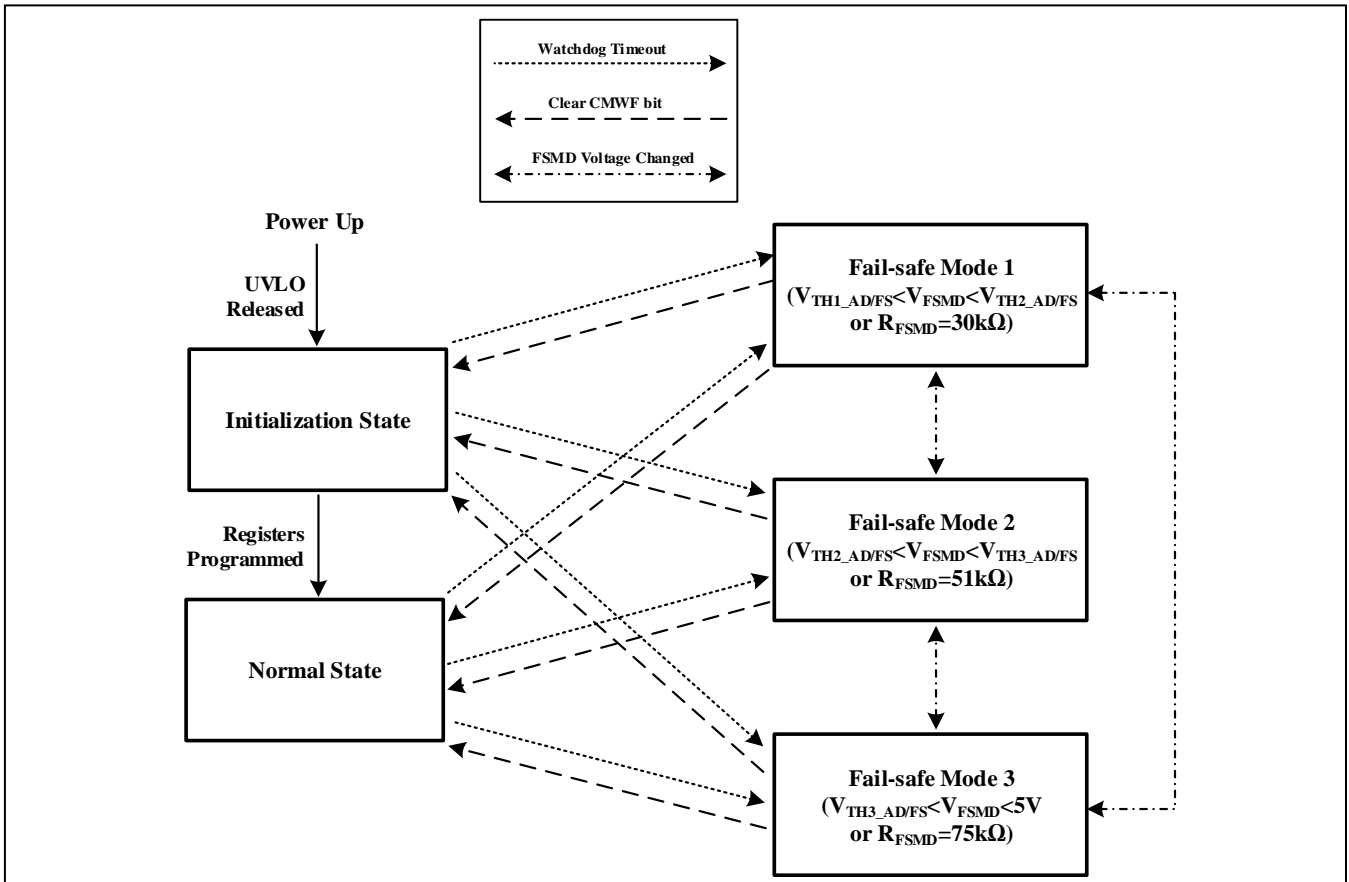

Figure 25 Operation States

## 10.2.6 14h~25h Scaling Registers

ADDR	REG NAME	D7	D6:D0	DEFAULT
14h	SCA1	-	SCA1_DATA [6:0]	0b 01111111
15h	SCA2	-	SCA2_DATA [6:0]	0b 01111111
16h	SCA3	-	SCA3_DATA [6:0]	0b 01111111
17h	SCA4	-	SCA4_DATA [6:0]	0b 01111111
18h	SCA5	-	SCA5_DATA [6:0]	0b 01111111
19h	SCA6	-	SCA6_DATA [6:0]	0b 01111111
1Ah	SCA7	-	SCA7_DATA [6:0]	0b 01111111
1Bh	SCA8	-	SCA8_DATA [6:0]	0b 01111111
1Ch	SCA9	-	SCA9_DATA [6:0]	0b 01111111
1Dh	SCA10	-	SCA10_DATA [6:0]	0b 01111111
1Eh	SCA11	-	SCA11_DATA [6:0]	0b 01111111
1Fh	SCA12	-	SCA12_DATA [6:0]	0b 01111111
20h	SCA13	-	SCA13_DATA [6:0]	0b 01111111
21h	SCA14	-	SCA14_DATA [6:0]	0b 01111111
22h	SCA15	-	SCA15_DATA [6:0]	0b 01111111
23h	SCA16	-	SCA16_DATA [6:0]	0b 01111111
24h	SCA17	-	SCA17_DATA [6:0]	0b 01111111
25h	SCA18	-	SCA18_DATA [6:0]	0b 01111111

# IS32LT3138

The 7-bit Scaling Registers SCAX (14h~25h) individually set the DC output current of each channel.

GCC[5:0] and SCAX control the OUTx current ( $I_{OUTx}$ ) as shown in following equation:

$$I_{OUTx} = I_{OUT\_FU} \times \frac{GCC}{64} \times \frac{SCAx}{128} \quad (5)$$

Where, x is from 1 to 18 for different output channel.

$$GCC = \sum_{n=0}^5 D[n] \cdot 2^n \quad (6)$$

$$SCAx = \sum_{n=0}^6 D[n] \cdot 2^n \quad (7)$$

## 10.2.7 26h~40h PWM Registers

ADDR	REG NAME	D7	D6	D5	D4	D3	D2	D1	D0	DEFAULT
26h	PWM1_H	PWM1_DATA [11:4]								0b 00000000
27h	PWM2_H	PWM2_DATA [11:4]								0b 00000000
28h	PWM1_2_L	PWM2_DATA [3:0]				PWM1_DATA [3:0]				0b 00000000
29h	PWM3_H	PWM3_DATA [11:4]								0b 00000000
2Ah	PWM4_H	PWM4_DATA [11:4]								0b 00000000
2Bh	PWM3_4_L	PWM4_DATA [3:0]				PWM3_DATA [3:0]				0b 00000000
2Ch	PWM5_H	PWM5_DATA [11:4]								0b 00000000
2Dh	PWM6_H	PWM6_DATA [11:4]								0b 00000000
2Eh	PWM5_6_L	PWM6_DATA [3:0]				PWM5_DATA [3:0]				0b 00000000
2Fh	PWM7_H	PWM7_DATA [11:4]								0b 00000000
30h	PWM8_H	PWM8DATA [11:4]								0b 00000000
31h	PWM7_8_L	PWM8_DATA [3:0]				PWM7_DATA [3:0]				0b 00000000
32h	PWM9_H	PWM9_DATA [11:4]								0b 00000000
33h	PWM10_H	PWM10_DATA [11:4]								0b 00000000
34h	PWM9_10_L	PWM10_DATA [3:0]				PWM9_DATA [3:0]				0b 00000000
35h	PWM11_H	PWM11_DATA [11:4]								0b 00000000
36h	PWM12_H	PWM12_DATA [11:4]								0b 00000000
37h	PWM11_12_L	PWM12_DATA [3:0]				PWM11_DATA [3:0]				0b 00000000
38h	PWM13_H	PWM13_DATA [11:4]								0b 00000000
39h	PWM14_H	PWM14_DATA [11:4]								0b 00000000
3Ah	PWM13_14_L	PWM14_DATA [3:0]				PWM13_DATA [3:0]				0b 00000000
3Bh	PWM15_H	PWM15_DATA [11:4]								0b 00000000
3Ch	PWM16_H	PWM16_DATA [11:4]								0b 00000000
3Dh	PWM15_16_L	PWM16_DATA [3:0]				PWM15_DATA [3:0]				0b 00000000
3Eh	PWM17_H	PWM17_DATA [11:4]								0b 00000000
3Fh	PWM18_H	PWM18_DATA [11:4]								0b 00000000
40h	PWM17_18_L	PWM18_DATA [3:0]				PWM17_DATA [3:0]				0b 00000000

**Note 14:** To ensure the accuracy of results in single-LED short detect, LED-short detect and LED-open detect, the PWM value should be more than 25%. For example, if PWM mode is 8-bit, the PWM value should be more than 0x40.

Each OUTx has 12-bit (or 7+5-bit) to modulate the PWM duty cycle in 4096 steps.

The value of the PWM Registers decides the average current of each OUTx LED noted  $I_{LED}$ .

$I_{LED}$  computed by following formula:

# IS32LT3138

$$I_{OUTx\_PWM} = I_{OUTx} \times D_{PWMx} \quad (8)$$

Where,  $D_{PWMx}$  is duty cycle of each channel independently programmed by PWM Registers (26h~40h), in 12bit or 7+5-bit PWM mode:

$$D_{PWMx} = \frac{\sum_{n=0}^{11} D[n] \cdot 2^n}{4096} \quad (9)$$

In 8bit PWM mode:

$$D_{PWMx} = \frac{\sum_{n=4}^{11} D[n] \cdot 2^n}{256} \quad (10)$$

## 10.2.8 41h~49h Single LED Short Threshold Setting Registers

ADDR	REG NAME	D7	D6	D5	D4	D3	D2	D1	D0	DEFAULT
41h	LED1_2_SLS	LED2_SLSTH[3:0]			LED1_SLSTH [3:0]					0b 00000000
42h	LED3_4_SLS	LED4_SLSTH[3:0]			LED3_SLSTH [3:0]					0b 00000000
43h	LED5_6_SLS	LED6_SLSTH[3:0]			LED5_SLSTH [3:0]					0b 00000000
44h	LED7_8_SLS	LED8_SLSTH[3:0]			LED7_SLSTH [3:0]					0b 00000000
45h	LED9_10_SLS	LED10_SLSTH[3:0]			LED9_SLSTH [3:0]					0b 00000000
46h	LED11_12_SLS	LED12_SLSTH[3:0]			LED11_SLSTH [3:0]					0b 00000000
47h	LED13_14_SLS	LED14_SLSTH[3:0]			LED13_SLSTH [3:0]					0b 00000000
48h	LED15_16_SLS	LED16_SLSTH[3:0]			LED15_SLSTH [3:0]					0b 00000000
49h	LED17_18_SLS	LED18_SLSTH[3:0]			LED17_SLSTH [3:0]					0b 00000000

LED<sub>x</sub>\_SLSTH sets the single LED short detection threshold for each channel,  $V_{SLSTH}$ , and in order to detect the result correctly,  $V_{SLSTH}$  should be set to be higher than OUT<sub>x</sub> voltage when single LED short or make LED+ supply voltage higher.

For example:

Condition 1, if LED+ supply voltage is 7V, LED V<sub>F</sub> is 2.6V, and connect 2 LEDs, so the OUT<sub>x</sub> voltage is 1.8V(=7V-2\*2.6V), so the V<sub>SLSTH</sub> suggest setting as 3.2V (LED<sub>x</sub>\_SLSTH = "0001").

Condition 2, if channel is only with one LED and LED V<sub>F</sub> is 1.8V~2.2V, suggest that the LED+ supply voltage is higher than 2.7V (V<sub>F</sub> + headroom voltage) to make sure the detect result is correct.

LED <sub>x</sub> _SLSTH	Singe LED short threshold voltage
0000	2.5V
0001	3.2V
0010	3.9V
0011	4.6V
0100	5.3V
0101	6.0V
0110	6.7V
0111	7.4V
1000	8.1V
1001	8.8V
1010	9.5V
1011	10.2V
1100	11.4V
1101	12.6V
1110	13.8V
1111	15.0V

# IS32LT3138

## 10.2.9 4Ah System Configuration Register (SYSCFG) – Read/Write

ADDR	REG NAME	D7	D6:D5	D4	D3:D1	D0	DEFAULT
4Ah	SYSCFG	SSCEN	SSC [1:0]	ACKEN	CMWTAP [2:0]	PWR	0b 00001000

**ACKEN** Acknowledge Enable  
 0 No acknowledge is transmitted following successfully received writes  
 1 Acknowledge (0x7F) is transmitted following successfully received writes

**PWR** This bit is reset to 0 upon power-up. It may be written to a 1 by the MCU. Reading this bit allows the MCU to detect if there has been a power cycle.  
 0 A power cycle has occurred since last write to a '1'  
 1 No power cycle has occurred since the last write to a '1'

**CMWTAP [2:0]** This 3-bit value selects the tap point (i.e., bit number, starting from 0) on the 24-bit communications watchdog timer to establish the time-out condition.

CMWTAP [2:0]	Time-Out Time
7	1024ms
6	512ms
5	256ms
4	128ms (Default)
3	64ms
2	32ms
1	16ms
0	8ms

**SSCEN** Spread Spectrum Enable  
 0 Disable  
 1 Enable-not allowed when PWM frequency is 244Hz

**SSC** Spread Spectrum frequency Range  
 00 125Hz  
 01 250Hz  
 10 500Hz  
 11 1kHz

## 10.2.10 4Bh FS\_FLTL Register

ADDR	REG NAME	D7	D6:D4	D3:D0	DEFAULT
4Bh	FS_FLTL	-	SHORT_FLT	FLT_UV	0b 00000100

FLT\_UV set UVLO threshold  $V_{FLT\_UV}$  for the LED open fault detection and single LED short fault detect false fault triggering due to insufficient power supply voltage.

SHORT\_FLT sets the LED string short detection threshold,  $V_{SC}$ , and to detect the result correctly,  $V_{SC}$  should be set to be smaller than LED+ supply voltage.

For example:

Condition 1, if LED+ supply voltage is 14V, the  $V_{SC}$  suggest setting to be  $V_{IN}-1V$ (SHORT\_FLT = "000") or 12V (SHORT\_FLT = "101").

Condition 2, if LED+ supply voltage is 10V, the  $V_{SC}$  suggest setting to be  $V_{IN}-1V$ (SHORT\_FLT = "000") or 8V (SHORT\_FLT = "110").

# IS32LT3138

<b>FLT_UV</b>	UVLO threshold voltage for the LED open fault detection and single LED short fault detection
0000	4.5V
0001	5V
0010	6V
0011	7V
0100	8V
0101	9V
0110	10V
0111	11V
1000	12V
1001	13V
1010	14V
1011	15V
1100	16V
1101	16V
1110	16V
1111	16V

<b>SHORT_FLT</b>	LED short threshold voltage
000	VIN-1V
001	10V
010	6V
011	14V
100	5V
101	12V
110	8V
111	Reserve

## 10.2.11 4Ch Diagnostic Register

ADDR	REG NAME	D7:D6	D5	D4	D3	D2	D1	D0	DEFAULT
4Ch	FLT_DET_EN	-	SLSDF	SLSDE	SDF	SDE	ODF	ODE	0b 00001111

**SLSDF** Single LED Short Report Enable at FAULTB pin  
 0 Report disabled  
 1 Report enabled

**SLSDE** Single LED Short Detect Enable  
 0 Detect disabled  
 1 Detect enabled

**SDF** Short Report Enable at FAULTB pin  
 0 Report disabled  
 1 Report enabled

**SDE** Short Detect Enable  
 0 Detect disabled  
 1 Detect enabled

**ODF** Open Report Enable at FAULTB pin  
 0 Report disabled  
 1 Report enabled

**ODE**                    Open Detect Enable  
 0                        Detect disabled  
 1                        Detect enabled

## 10.2.12 4Dh~56h Diagnostic Registers

ADDR	REG NAME	D7	D6	D5	D4	D3	D2	D1	D0	DEFAULT
4Dh	FLT_CONFIG	-	SHCR	OPENCR	SLSHCR	FT[3:0]				0b 01100011
4Eh	SHORT_FLT1	-	-	SHORT_FLT[6:1]						0b 00000000
4Fh	SHORT_FLT2	-	-	SHORT_FLT[12:7]						0b 00000000
50h	SHORT_FLT3	-	-	SHORT_FLT[18:13]						0b 00000000
51h	OPEN_FLT1	-	-	OPEN_FLT[6:1]						0b 00000000
52h	OPEN_FLT2	-	-	OPEN_FLT[12:7]						0b 00000000
53h	OPEN_FLT3	-	-	OPEN_FLT[18:13]						0b 00000000
54h	SLS_FLT1	-	-	SLS_FLT[6:1]						0b 00000000
55h	SLS_FLT2	-	-	SLS_FLT[12:7]						0b 00000000
56h	SLS_FLT3	-	-	SLS_FLT[18:13]						0b 00000000

**FT**                    Fault report delay time setting  
 0000                    32us  
 0001                    64us  
 0010                    128us  
 0011                    256us  
 0100                    512us  
 0101                    1.024ms  
 0110                    2.048ms  
 0111                    4.096ms  
 1000                    7.8125ms  
 1001                    15.625ms  
 1010                    31.25ms  
 1011                    62.5ms  
 1100                    0.125s  
 1101                    0.25s  
 1110                    0.5s  
 1111                    1s

**SLSHCR**            single LED short output current reduce  
 0                        No reduce  
 1                        Output current reduced to 4mA (Typ.)

**SHCR**                LED short output current reduce  
 0                        No reduce  
 1                        Output current reduced to 4mA (Typ.)

**OPENCR**            LED OPEN output current reduce  
 0                        No reduce  
 1                        Output current reduced to 4mA (Typ.)

**SHORT\_FLTx**        LED string short fault flag for each OUT1~OUT18  
 0                        No LED string shorted  
 1                        LED string shorted

# IS32LT3138

**OPEN\_FLTx** LED string open fault flag for each OUT1~OUT18  
 0 No LED string open  
 1 LED string open

**SLS\_FLTx** Single LED short fault flag for each OUT1~OUT18  
 0 No single LED shorted  
 1 Single LED shorted

## 10.2.13 57h Fault Type Registers

ADDR	REG NAME	D7	D6	D5	D4	D3	D2	D1	D0	DEFAULT
57	FAULT_TYPE	TF	CRCF	RSET_SH	CMWF	TSD	SLSHORTF	SHORTF	OPENF	0b 00000000

Fault flags. When bit=1, fault flag is asserted.

**TF** Thermal rolloff fault flag  
 0 No thermal rolloff  
 1 Thermal rolloff

**RSET\_SH** ISET pin short fault flag  
 0 No short  
 1 Shorted

**CRCF** Interface communication Check Sum Failure fault flag  
 0 No communication Check Sum Failure  
 1 Communication Check Sum Failure

**CMWF** Communication Time-Out fault flag  
 0 No communication time-out  
 1 Communication time-out

**TSD** Thermal shutdown fault flag  
 0 No thermal shutdown  
 1 Thermal shutdown

**SLSHORTF** Single LED Short fault flag. Any out occurs single LED short, this bit will set to 1.  
 0 No single LED short  
 1 Single LED short

**SHORTF** LED Short fault flag. Any out occurs LED short, this bit will set to 1.  
 0 No LED short  
 1 LED short

**OPENF** LED Open fault flag. Any out occurs LED open, this bit will set to 1.  
 0 No LED open  
 1 LED open

## 10.2.14 Diagnostic Register (Continue)

ADDR	REG NAME	D7:D0	DEFAULT
59h	CERRCNT	CERRCNT [7:0]	0b 00000000

This register value is incremented each time a CRC error is received. This register may be read by the MCU and then written back to 0 to clear the count. The CERRCNT value saturates at FFh; it does not wrap back to 0 when it reaches FFh. The CERRCNT register is not automatically cleared when a communications reset is received. It must be cleared manually by writing it back to 0. Note that the CERRCNT register can be written to any 8-bit value. This is intended for diagnostic purposes.

## 11 CLASSIFICATION REFLOW PROFILES

Profile Feature	Pb-Free Assembly
Preheat & Soak Temperature min (T <sub>smin</sub> ) Temperature max (T <sub>smax</sub> ) Time (T <sub>smin</sub> to T <sub>smax</sub> ) (t <sub>s</sub> )	150°C 200°C 60-120 seconds
Average ramp-up rate (T <sub>smax</sub> to T <sub>p</sub> )	3°C/second max.
Liquidous temperature (T <sub>L</sub> ) Time at liquidous (t <sub>L</sub> )	217°C 60-150 seconds
Peak package body temperature (T <sub>p</sub> )*	Max 260°C
Time (t <sub>p</sub> )** within 5°C of the specified classification temperature (T <sub>c</sub> )	Max 30 seconds
Average ramp-down rate (T <sub>p</sub> to T <sub>smax</sub> )	6°C/second max.
Time 25°C to peak temperature	8 minutes max.

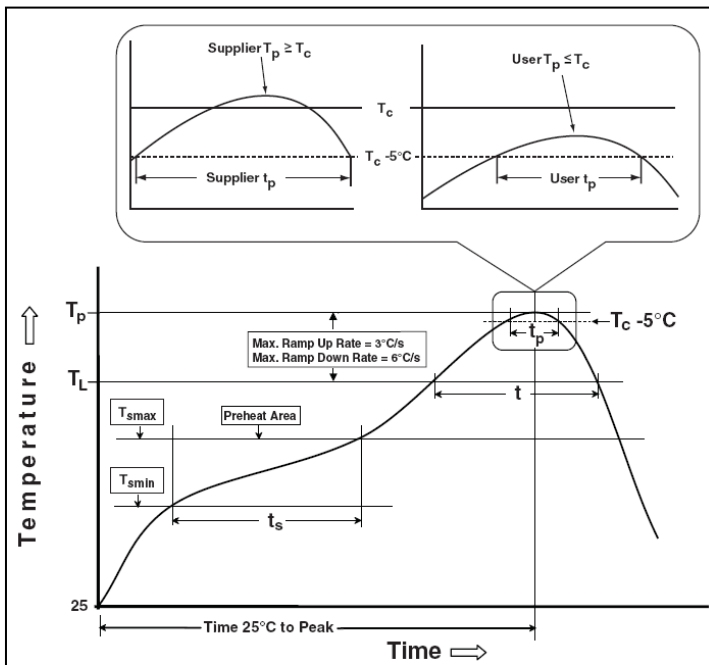

Figure 26 Classification Profile



# IS32LT3138

## 12 PACKAGE INFORMATION

### WFQFN-32 (IS32LT3138-QWLA3-TR)

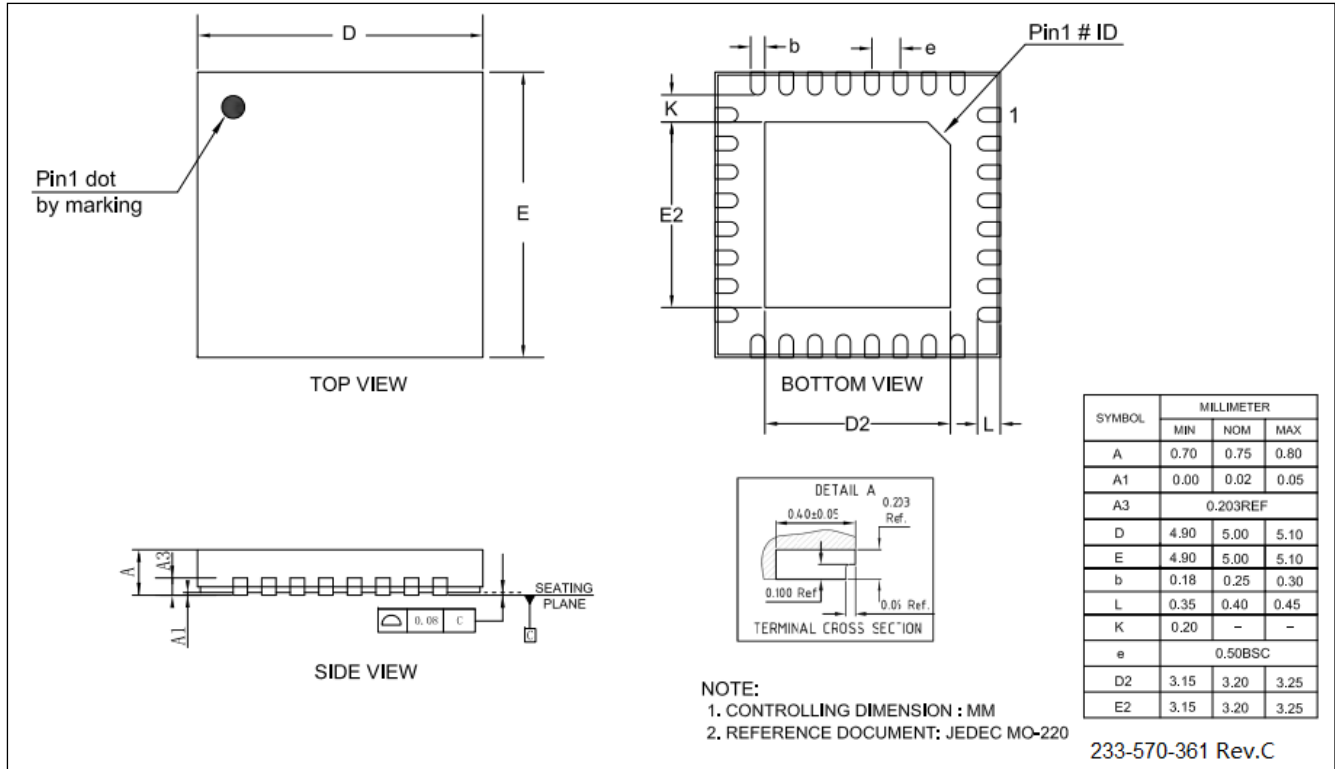

## WFQFN-32 (IS32LT3138-QWLCA3-TR) (with copper wire bonding)

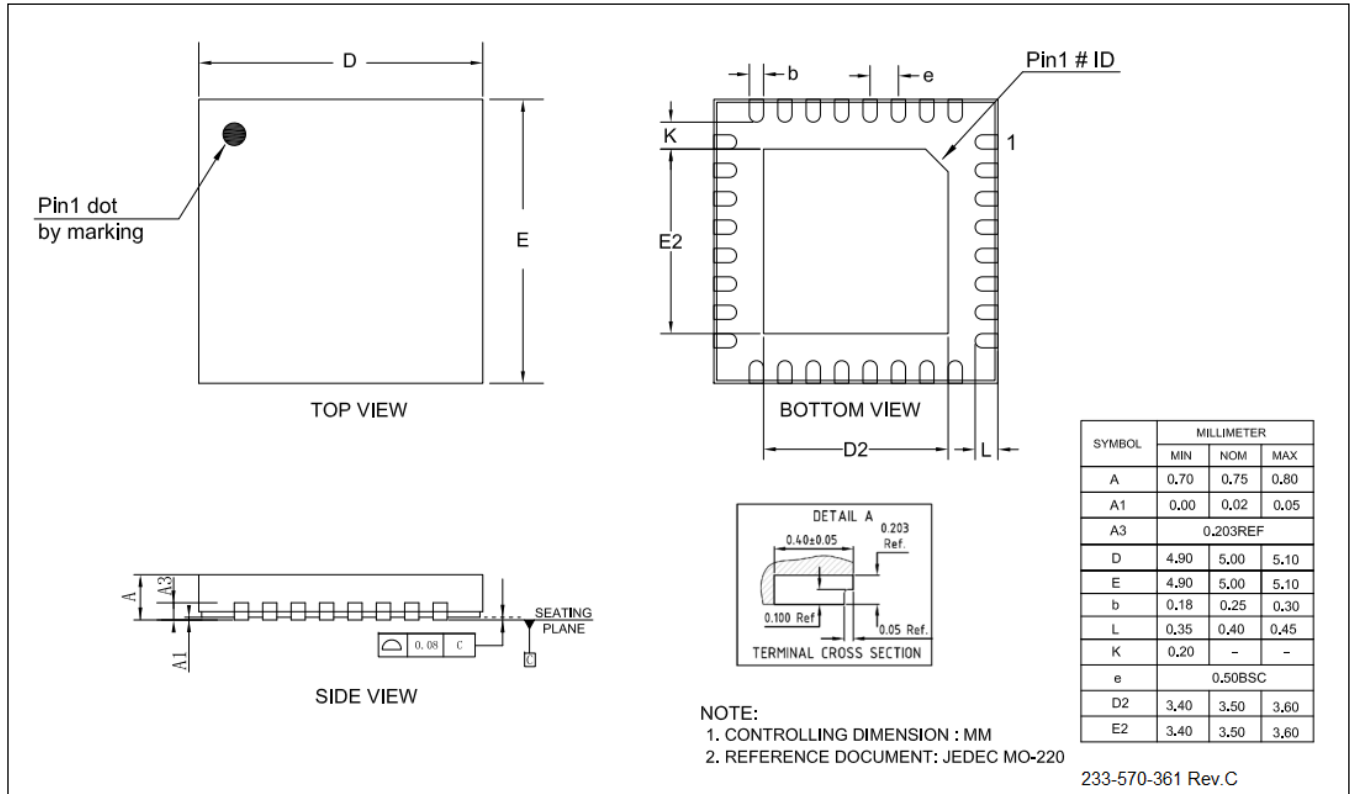

# IS32LT3138

## 13 RECOMMENDED LAND PATTERN

### WFQFN-32 (IS32LT3138-QWLA3-TR)

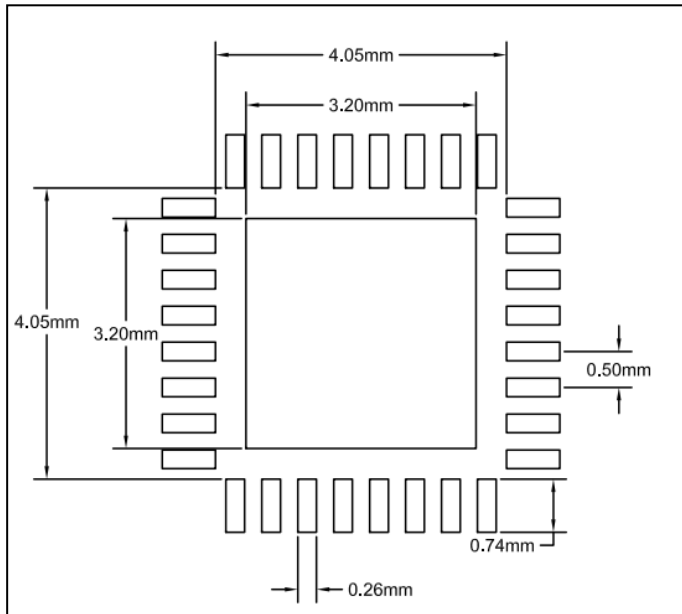

### WFQFN-32 (IS32LT3138-QWLCA3-TR) (with copper wire bonding)

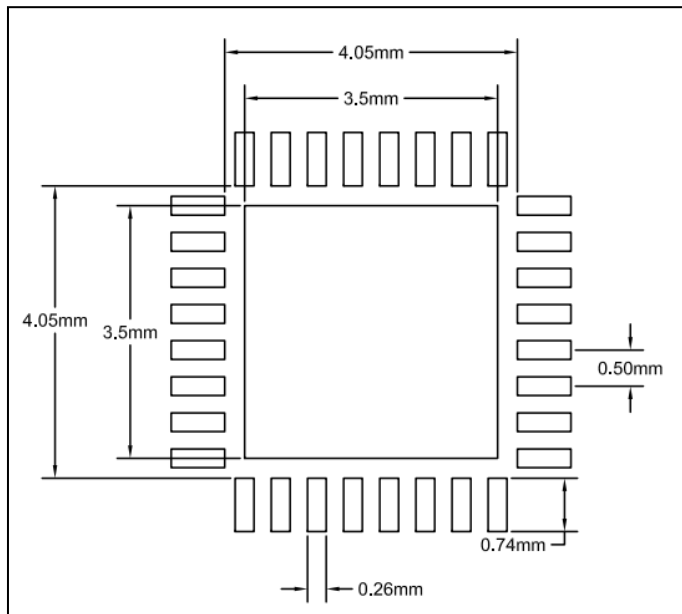

**Note:**

1. Land pattern complies to IPC-7351.
2. All dimensions in MM.
3. This document (including dimensions, notes & specs) is a recommendation based on typical circuit board manufacturing parameters. Since land pattern design depends on many factors unknown (eg. User's board manufacturing specs), user must determine suitability for use.

## 14 REVISION HISTORY

Revision	Detail Information	Date
0A	Initial release	2022.09.29
0B	<ol style="list-style-type: none"> <li>1. Remove <math>V_{HR}</math> 25°C value in EC table</li> <li>2. Remove the “2^clk” in CMWTAP, remove PSE in 03h</li> </ol>	2022.11.03
0C	<ol style="list-style-type: none"> <li>1. Modify <math>I_{OUT}</math> mismatch and accuracy data introduce of Features</li> <li>2. Increase EC table different temperature symbol</li> <li>3. Update EC table data and condition</li> <li>4. Increase note about <math>\Delta_{MAT}</math> and <math>\Delta_{OUT}</math> calculate methods</li> <li>5. Update Application Information content</li> <li>6. Increase R/W explain with register map</li> <li>7. Update default data of register map</li> <li>8. FLT_UV 4V update to 4.5V</li> <li>9. Update current range of CM bit of 00h</li> <li>10. Update 4Ah default value to 0x08 (CMWTAP = 128ms)</li> <li>11. Update 4Bh default value to 0x04 (FLT_UV = 8V)</li> <li>12. Increase LED string short detect and single LED short detect threshold notes</li> <li>13. Update Bus Reset introduce and picture</li> </ol>	2023.02.24
A	<ol style="list-style-type: none"> <li>1. Update 9.2.8, 41h~49h Single LED Short Threshold Setting Registers, correct the examples</li> <li>2. Update 8.7.4.2, Device ID Byte information, modify Device ID setting resistance value (50k to 51k, 70k to 75k) and correct some errors in the device ID table</li> <li>3. Modify 8.9.4, Fail-safe Mode Setting Table 68k to 75k</li> <li>4. Modify EC table data and information</li> </ol>	2023.07.10
B	<ol style="list-style-type: none"> <li>1. Add Note 2 about IS32LT3138-QWLCA3-TR is with copper wire bonding</li> <li>2. Add Note 9 about reconnect TX or RX's CRC error issue</li> <li>3. Add Note 12 about Device ID detect</li> <li>4. Add Note 14 about ensuring LED open/short detect and single LED short detection accuracy</li> <li>5. Add Package Information for IS32LT3138-QWLCA3-TR (with copper wire bonding)</li> <li>6. Add Recommended Land Pattern for IS32LT3138-QWLCA3-TR (with copper wire bonding)</li> </ol>	2024.05.10