

IS61WV25632ALL/ALS IS61WV25632BLL/BLS IS64WV25632BLL/BLS



256K x 32 HIGH-SPEED ASYNCHRONOUS CMOS STATIC RAM WITH 3.3V SUPPLY

MAY 2023

FEATURES

- High-speed access times: 8, 10, 20 ns
- High-performance, low-power CMOS process
- Multiple center power and ground pins for greater noise immunity
- Easy memory expansion with \overline{CE} and \overline{OE} options
- \overline{CE} power-down
- Fully static operation: no clock or refresh required
- TTL compatible inputs and outputs
- Single power supply
V_{DD} 1.65V to 2.2V (IS61WV25632Axx)
speed = 20ns for V_{DD} 1.65V to 2.2V
V_{DD} 2.4V to 3.6V (IS61/64WV25632Bxx)
speed = 10ns for V_{DD} 2.4V to 3.6V
speed = 8ns for V_{DD} 3.3V ± 5%
- Packages available:
 - 90-ball miniBGA (8mm x 13mm)
- Industrial and Automotive Temperature Support

DESCRIPTION

The *ISSI* IS61WV25632Axx/Bxx and IS64WV25632Bxx are high-speed, 8M-bit static RAMs organized as 256K words by 32 bits. It is fabricated using *ISSI*'s high-performance CMOS technology. This highly reliable process coupled with innovative circuit design techniques, yields high-performance and low power consumption devices.

When \overline{CE} is HIGH (deselected), the device assumes a standby mode at which the power dissipation can be reduced down with CMOS input levels.

Easy memory expansion is provided by using Chip Enable and Output Enable inputs, \overline{CE} and \overline{OE} . The active LOW Write Enable (\overline{WE}) controls both writing and reading of the memory.

The device is packaged in the JEDEC standard 90-ball BGA (8mm x 13mm).

FUNCTIONAL BLOCK DIAGRAM

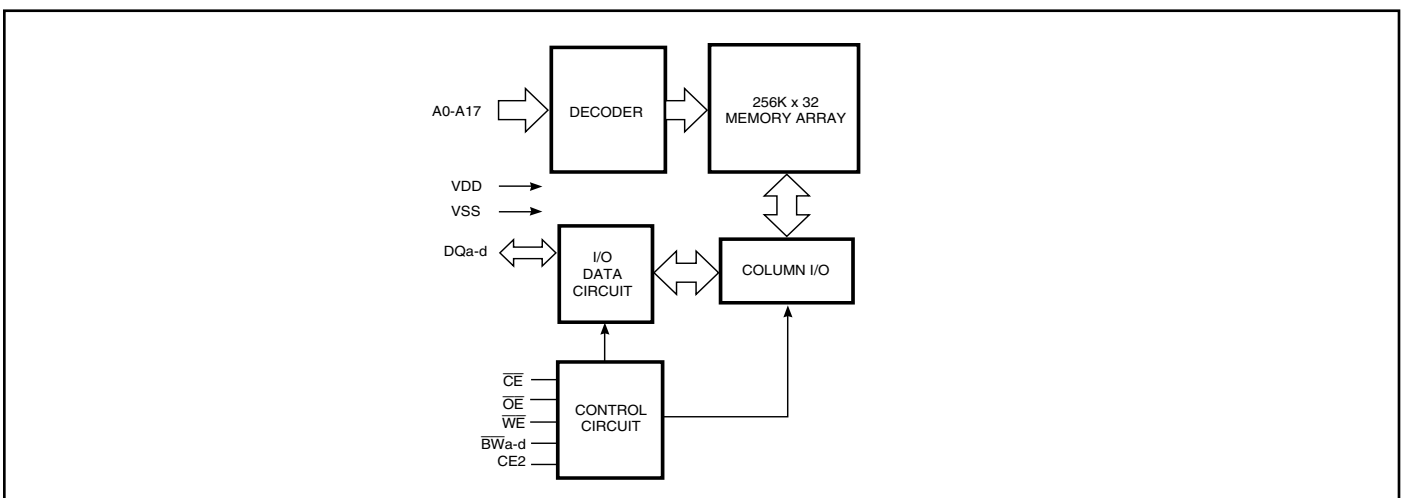

Copyright © 2023 Integrated Silicon Solution, Inc. All rights reserved. ISSI reserves the right to make changes to this specification and its products at any time without notice. ISSI assumes no liability arising out of the application or use of any information, products or services described herein. Customers are advised to obtain the latest version of this device specification before relying on any published information and before placing orders for products.

Integrated Silicon Solution, Inc. does not recommend the use of any of its products in life support applications where the failure or malfunction of the product can reasonably be expected to cause failure of the life support system or to significantly affect its safety or effectiveness. Products are not authorized for use in such applications unless Integrated Silicon Solution, Inc. receives written assurance to its satisfaction, that:

- a.) the risk of injury or damage has been minimized;
- b.) the user assume all such risks; and
- c.) potential liability of Integrated Silicon Solution, Inc is adequately protected under the circumstances

PIN CONFIGURATION

PACKAGE CODE: B 90 BALL FBGA (Top View) (8.00 mm x 13.00 mm Body, 0.8 mm Ball Pitch)

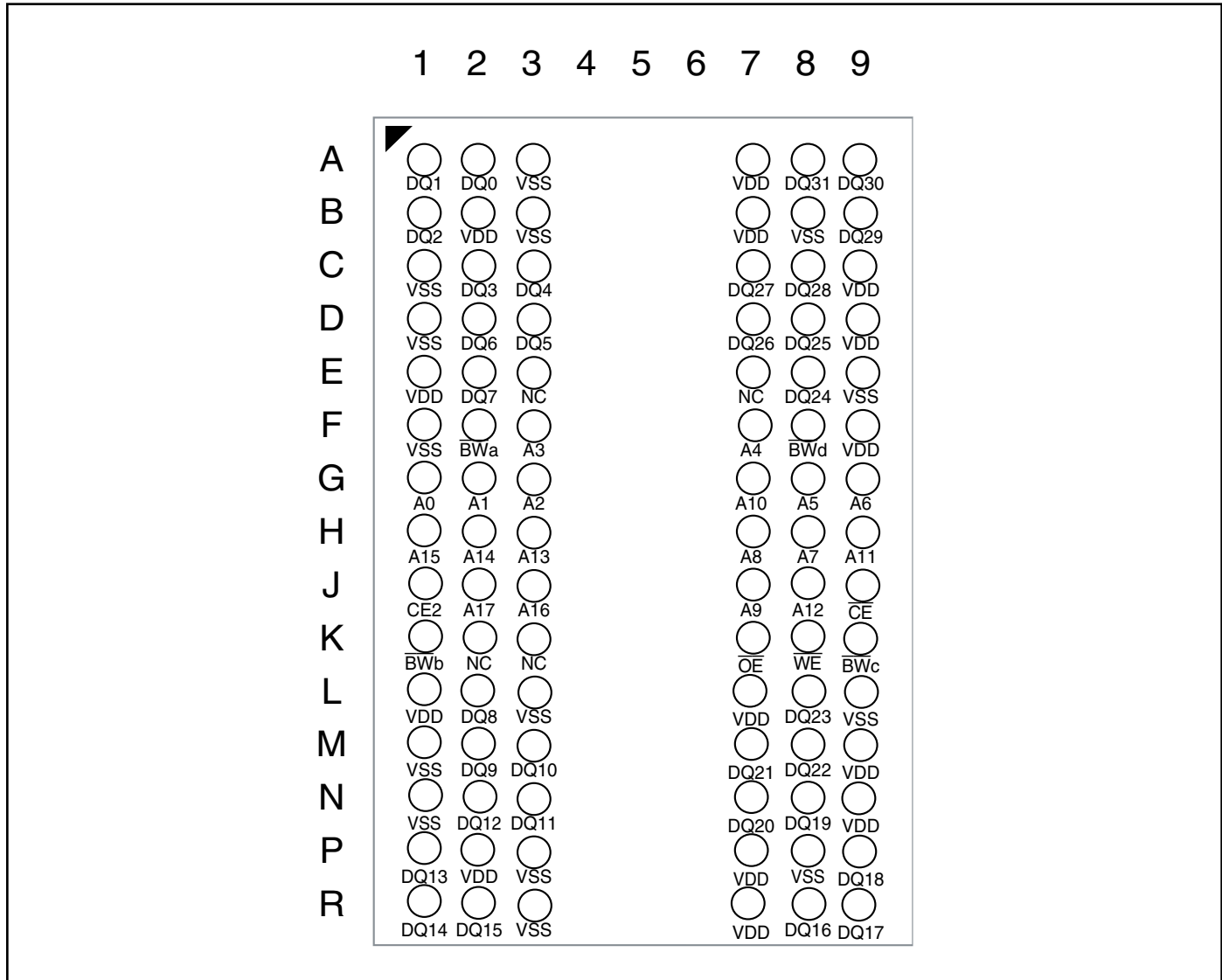

PIN DESCRIPTIONS

A0-A17	Address Inputs
DQx	Data I/O
CE, CE ₂	Chip Enable Input
OE	Output Enable Input
WE	Write Enable Input
BW _x (x=a-d)	Byte Write Control
VDD	Power
Vss	Ground
NC	No Connection

TRUTH TABLE

\overline{CE}	$\overline{CE2}$	\overline{OE}	\overline{WE}	\overline{BWA}	\overline{BWB}	\overline{BWC}	\overline{BWD}	DQ ₀₋₇	DQ ₈₋₁₅	DQ ₁₆₋₂₃	DQ ₂₄₋₃₁	Mode	Power
H	X	X	X	X	X	X	X	High-Z	High-Z	High-Z	High-Z	Power Down	(Isb)
X	L	X	X	X	X	X	X	High-Z	High-Z	High-Z	High-Z	Power Down	(Isb)
L	H	L	H	L	L	L	L	Data Out	Data Out	Data Out	Data Out	Read All Bits	(Icc)
L	H	L	H	L	H	H	H	Data Out	High-Z	High-Z	High-Z	Read Byte a Bits Only	(Icc)
L	H	L	H	H	L	H	H	High-Z	Data Out	High-Z	High-Z	Read Byte b Bits Only	(Icc)
L	H	L	H	H	H	L	H	High-Z	High-Z	Data Out	High-Z	Read Byte c Bits Only	(Icc)
L	H	L	H	H	H	H	L	High-Z	High-Z	High-Z	Data Out	Read Byte d Bits Only	(Icc)
L	H	X	L	L	L	L	L	Data In	Data In	Data In	Data In	Write All Bits	(Icc)
L	H	X	L	L	H	H	H	Data In	High-Z	High-Z	High-Z	Write Byte a Bits Only	(Icc)
L	H	X	L	H	L	H	H	High-Z	Data In	High-Z	High-Z	Write Byte b Bits Only	(Icc)
L	H	X	L	H	H	L	H	High-Z	High-Z	Data In	High-Z	Write Byte c Bits Only	(Icc)
L	H	X	L	H	H	H	L	High-Z	High-Z	High-Z	Data In	Write Byte d Bits Only	(Icc)
L	H	H	H	X	X	X	X	High-Z	High-Z	High-Z	High-Z	Selected, Outputs Disabled	(Icc)

ABSOLUTE MAXIMUM RATINGS⁽¹⁾

Symbol	Parameter	Value	Unit
V _{TERM}	Terminal Voltage with Respect to GND	-0.5 to V _{DD} + 0.5	V
V _{DD}	V _{DD} Relates to GND	-0.3 to 4.0	V
T _{STG}	Storage Temperature	-65 to +150	°C
P _T	Power Dissipation	1.0	W

Notes:

1. Stress greater than those listed under ABSOLUTE MAXIMUM RATINGS may cause permanent damage to the device. This is a stress rating only and functional operation of the device at these or any other conditions above those indicated in the operational sections of this specification is not implied. Exposure to absolute maximum rating conditions for extended periods may affect reliability.

CAPACITANCE^(1,2)

Symbol	Parameter	Conditions	Max.	Unit
C _{IN}	Input Capacitance	V _{IN} = 0V	6	pF
C _{I/O}	Input/Output Capacitance	V _{OUT} = 0V	8	pF

Notes:

1. Tested initially and after any design or process changes that may affect these parameters.
2. Test conditions: T_A = 25°C, f = 1 MHz, V_{DD} = 3.3V.

DC ELECTRICAL CHARACTERISTICS (Over Operating Range)

V_{DD} = 3.3V ± 5%

Symbol	Parameter	Test Conditions	Min.	Max.	Unit
V _{OH}	Output HIGH Voltage	V _{DD} = Min., I _{OH} = -4.0 mA	2.4	—	V
V _{OL}	Output LOW Voltage	V _{DD} = Min., I _{OL} = 8.0 mA	—	0.4	V
V _{IH}	Input HIGH Voltage		2	V _{DD} + 0.3	V
V _{IL}	Input LOW Voltage ⁽¹⁾		-0.3	0.8	V
I _{LI}	Input Leakage	GND ≤ V _{IN} ≤ V _{DD}	-1	1	μA
I _{LO}	Output Leakage	GND ≤ V _{OUT} ≤ V _{DD} , Outputs Disabled	-1	1	μA

Note:

- V_{IL} (min.) = -0.3V DC; V_{IL} (min.) = -2.0V AC (pulse width 2.0 ns). Not 100% tested.
 V_{IH} (max.) = V_{DD} + 0.3V DC; V_{IH} (max.) = V_{DD} + 2.0V AC (pulse width 2.0 ns). Not 100% tested.

DC ELECTRICAL CHARACTERISTICS (Over Operating Range)

V_{DD} = 2.4V-3.6V

Symbol	Parameter	Test Conditions	Min.	Max.	Unit
V _{OH}	Output HIGH Voltage	V _{DD} = Min., I _{OH} = -1.0 mA	1.8	—	V
V _{OL}	Output LOW Voltage	V _{DD} = Min., I _{OL} = 1.0 mA	—	0.4	V
V _{IH}	Input HIGH Voltage		2.0	V _{DD} + 0.3	V
V _{IL}	Input LOW Voltage ⁽¹⁾		-0.3	0.8	V
I _{LI}	Input Leakage	GND ≤ V _{IN} ≤ V _{DD}	-1	1	μA
I _{LO}	Output Leakage	GND ≤ V _{OUT} ≤ V _{DD} , Outputs Disabled	-1	1	μA

Note:

- V_{IL} (min.) = -0.3V DC; V_{IL} (min.) = -2.0V AC (pulse width 2.0 ns). Not 100% tested.
 V_{IH} (max.) = V_{DD} + 0.3V DC; V_{IH} (max.) = V_{DD} + 2.0V AC (pulse width 2.0 ns). Not 100% tested.

DC ELECTRICAL CHARACTERISTICS (Over Operating Range)

V_{DD} = 1.65V-2.2V

Symbol	Parameter	Test Conditions	V _{DD}	Min.	Max.	Unit
V _{OH}	Output HIGH Voltage	I _{OH} = -0.1 mA	1.65-2.2V	1.4	—	V
V _{OL}	Output LOW Voltage	I _{OL} = 0.1 mA	1.65-2.2V	—	0.2	V
V _{IH}	Input HIGH Voltage		1.65-2.2V	1.4	V _{DD} + 0.2	V
V _{IL} ⁽¹⁾	Input LOW Voltage		1.65-2.2V	-0.2	0.4	V
I _{LI}	Input Leakage	GND ≤ V _{IN} ≤ V _{DD}		-1	1	μA
I _{LO}	Output Leakage	GND ≤ V _{OUT} ≤ V _{DD} , Outputs Disabled		-1	1	μA

Notes:

- V_{IL} (min.) = -0.3V DC; V_{IL} (min.) = -2.0V AC (pulse width -2.0ns). Not 100% tested.
 V_{IH} (max.) = V_{DD} + 0.3V DC; V_{IH} (max.) = V_{DD} + 2.0V AC (pulse width -2.0ns). Not 100% tested.

HIGH SPEED

OPERATING RANGE (V_{DD}) (IS61WV25632ALL)

Range	Ambient Temperature	V _{DD}	Speed
Commercial	0°C to +70°C	1.65V-2.2V	20ns
Industrial	-40°C to +85°C	1.65V-2.2V	20ns
Automotive	-40°C to +125°C	1.65V-2.2V	20ns

OPERATING RANGE (V_{DD}) (IS61WV25632BLL)⁽¹⁾

Range	Ambient Temperature	V _{DD} (8 ns) ¹	V _{DD} (10 ns) ¹
Commercial	0°C to +70°C	3.3V ± 5%	2.4V-3.6V
Industrial	-40°C to +85°C	3.3V ± 5%	2.4V-3.6V

Note:

- When operated in the range of 2.4V-3.6V, the device meets 10ns. When operated in the range of 3.3V ± 5%, the device meets 8ns.

OPERATING RANGE (V_{DD}) (IS64WV25632BLL)

Range	Ambient Temperature	V _{DD} (10 ns)
Automotive	-40°C to +125°C	2.4V-3.6V

POWER SUPPLY CHARACTERISTICS⁽¹⁾ (Over Operating Range)

Symbol	Parameter	Test Conditions	-8		-10		-20		Unit	
			Min.	Max.	Min.	Max.	Min.	Max.		
I _{CC}	V _{DD} Dynamic Operating Supply Current	V _{DD} = Max., I _{OUT} = 0 mA, f = f _{MAX}	Com.	—	110	—	90	—	50	mA
			Ind.	—	115	—	95	—	60	
			Auto. typ. ⁽²⁾	—	—	—	140	—	100	
I _{CC1}	Operating Supply Current	V _{DD} = Max., I _{OUT} = 0 mA, f = 0	Com.	—	85	—	85	—	45	mA
			Ind.	—	90	—	90	—	55	
			Auto.	—	—	—	110	—	90	
I _{SB1}	TTL Standby Current (TTL Inputs)	V _{DD} = Max., V _{IN} = V _{IH} or V _{IL} , CE ≥ V _{IH} , f = 0	Com.	—	30	—	30	—	30	mA
			Ind.	—	35	—	35	—	35	
			Auto.	—	—	—	70	—	70	
I _{SB2}	CMOS Standby Current (CMOS Inputs)	V _{DD} = Max., CE ≥ V _{DD} - 0.2V, V _{IN} ≥ V _{DD} - 0.2V, or V _{IN} ≤ 0.2V, f = 0	Com.	—	20	—	20	—	20	mA
			Ind.	—	25	—	25	—	25	
			Auto. typ. ⁽²⁾	—	—	—	60	—	60	
						4				

Note:

- At f = f_{MAX}, address and data inputs are cycling at the maximum frequency, f = 0 means no input lines change.
- Typical values are measured at V_{DD} = 3.0V, T_A = 25°C and not 100% tested.

LOW POWER

OPERATING RANGE (V_{DD}) (IS61WV25632ALS)

Range	Ambient Temperature	V _{DD}	Speed
Commercial	0°C to +70°C	1.65V-2.2V	35ns
Industrial	-40°C to +85°C	1.65V-2.2V	35ns
Automotive	-40°C to +125°C	1.65V-2.2V	35ns

OPERATING RANGE (V_{DD}) (IS61WV25632BLS)⁽¹⁾

Range	Ambient Temperature	V _{DD} (25 ns) ¹
Commercial	0°C to +70°C	2.4V-3.6V
Industrial	-40°C to +85°C	2.4V-3.6V

Note:

1. When operated in the range of 2.4V-3.6V, the device meets 25ns. When operated in the range of 3.3V ± 5%, the device meets 20ns.

POWER SUPPLY CHARACTERISTICS⁽¹⁾ (Over Operating Range)

Symbol	Parameter	Test Conditions		-25		-35		Unit
				Min.	Max.	Min.	Max.	
I _{CC}	V _{DD} Dynamic Operating Supply Current	V _{DD} = Max., I _{OUT} = 0 mA, f = f _{MAX}	Com.	—	30	—	25	mA
			Ind.	—	35	—	30	
			Auto.	—	60	—	60	
			typ. ⁽²⁾	25				
I _{CC1}	Operating Supply Current	V _{DD} = Max., I _{OUT} = 0 mA, f = 0	Com.	—	20	—	20	mA
			Ind.	—	30	—	30	
			Auto.	—	50	—	50	
I _{SB1}	TTL Standby Current (TTL Inputs)	V _{DD} = Max., V _{IN} = V _{IH} or V _{IL} CE ≥ V _{IH} , f = 0	Com.	—	15	—	15	mA
			Ind.	—	20	—	20	
			Auto.	—	40	—	40	
I _{SB2}	CMOS Standby Current (CMOS Inputs)	V _{DD} = Max., CE ≥ V _{DD} - 0.2V, V _{IN} ≥ V _{DD} - 0.2V, or V _{IN} ≤ 0.2V, f = 0	Com.	—	0.8	—	0.8	mA
			Ind.	—	1.2	—	1.2	
			Auto.	—	2	—	2	
			typ. ⁽²⁾	0.1		0.1		

Note:

1. At f = f_{MAX}, address and data inputs are cycling at the maximum frequency, f = 0 means no input lines change.
 2. Typical values are measured at V_{DD} = 3.0V, T_A = 25°C and not 100% tested.

AC TEST CONDITIONS (HIGH SPEED)

Parameter	Unit (2.4V-3.6V)	Unit (3.3V ± 5%)	Unit (1.65V-2.2V)
Input Pulse Level	0.4V to V _{DD} -0.3V	0.4V to V _{DD} -0.3V	0.4V to V _{DD} -0.2V
Input Rise and Fall Times	1.5ns	1.5ns	1.5ns
Input and Output Timing and Reference Level (V _{Ref})	V _{DD} /2	V _{DD} /2 + 0.05	V _{DD} /2
Output Load	See Figures 1 and 2	See Figures 1 and 2	See Figures 1 and 2

AC TEST LOADS

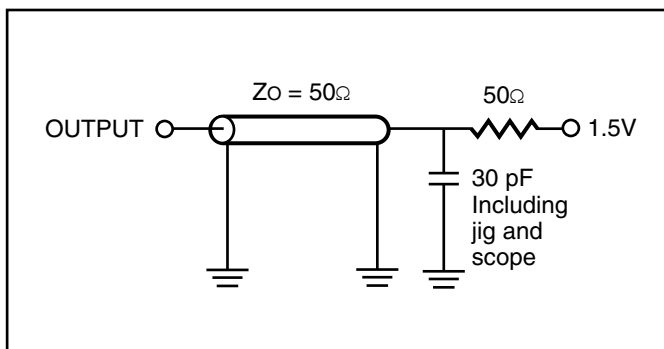

Figure 1.

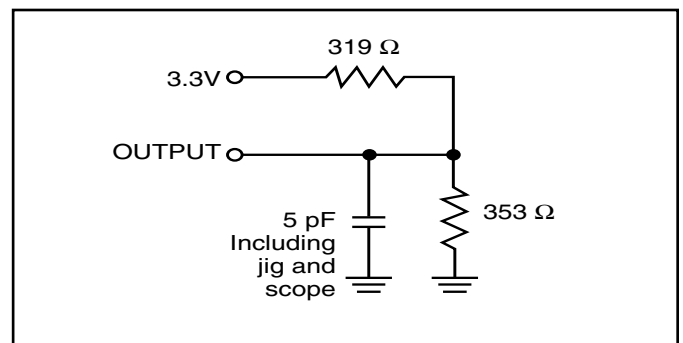

Figure 2.

READ CYCLE SWITCHING CHARACTERISTICS⁽¹⁾ (Over Operating Range)

Symbol	Parameter	-8		-10		Unit
		Min.	Max.	Min.	Max.	
t _{RC}	Read Cycle Time	8	—	10	—	ns
t _{AA}	Address Access Time	—	8	—	10	ns
t _{OHA}	Output Hold Time	2.5	—	2.5	—	ns
t _{ACE}	\overline{CE} Access Time	—	8	—	10	ns
t _{DOE}	\overline{OE} Access Time	—	5.5	—	6.5	ns
t _{HZOE⁽²⁾}	\overline{OE} to High-Z Output	—	3	—	4	ns
t _{LZOE⁽²⁾}	\overline{OE} to Low-Z Output	0	—	0	—	ns
t _{HZCE⁽²⁾}	\overline{CE} to High-Z Output	0	3	0	4	ns
t _{LZCE⁽²⁾}	\overline{CE} to Low-Z Output	3	—	3	—	ns
t _{BA}	Byte Enable to Data Valid	—	5.5	—	6.5	ns
t _{LZB}	Byte Enable to Low-Z	0	—	0	—	ns
t _{HZB}	Byte Enable to High-Z	0	3	0	3	ns

Notes:

1. Test conditions assume signal transition times of 3 ns or less, timing reference levels of 1.5V, input pulse levels of 0V to 3.0V and output loading specified in Figure 1.
2. Tested with the load in Figure 2. Transition is measured ± 500 mV from steady-state voltage.

READ CYCLE SWITCHING CHARACTERISTICS⁽¹⁾ (Over Operating Range)

Symbol	Parameter	-20 ns		Unit
		Min.	Max.	
t _{RC}	Read Cycle Time	20	—	ns
t _{AA}	Address Access Time	—	20	ns
t _{OHA}	Output Hold Time	2.5	—	ns
t _{ACE}	$\overline{\text{CE}}$ Access Time	—	20	ns
t _{DOE}	$\overline{\text{OE}}$ Access Time	—	8	ns
t _{HZOE⁽²⁾}	$\overline{\text{OE}}$ to High-Z Output	0	8	ns
t _{LZOE⁽²⁾}	$\overline{\text{OE}}$ to Low-Z Output	0	—	ns
t _{HZCE⁽²⁾}	$\overline{\text{CE}}$ to High-Z Output	0	8	ns
t _{LZCE⁽²⁾}	$\overline{\text{CE}}$ to Low-Z Output	3	—	ns
t _{BA}	Byte Enable to Data Valid	—	8	ns
t _{LZB}	Byte Enable to Low-Z	0	—	ns
t _{HZB}	Byte Enable to High-Z	0	3	ns

Notes:

1. Test conditions assume signal transition times of 1.5 ns or less, timing reference levels of 1.25V, input pulse levels of 0.4V to V_{DD}-0.3V and output loading specified in Figure 1a.
2. Tested with the load in Figure 1b. Transition is measured ± 500 mV from steady-state voltage. Not 100% tested.
3. Not 100% tested.

AC WAVEFORMS

READ CYCLE NO. 1^(1,2) ($\overline{CE} = \overline{OE} = V_{IL}$)

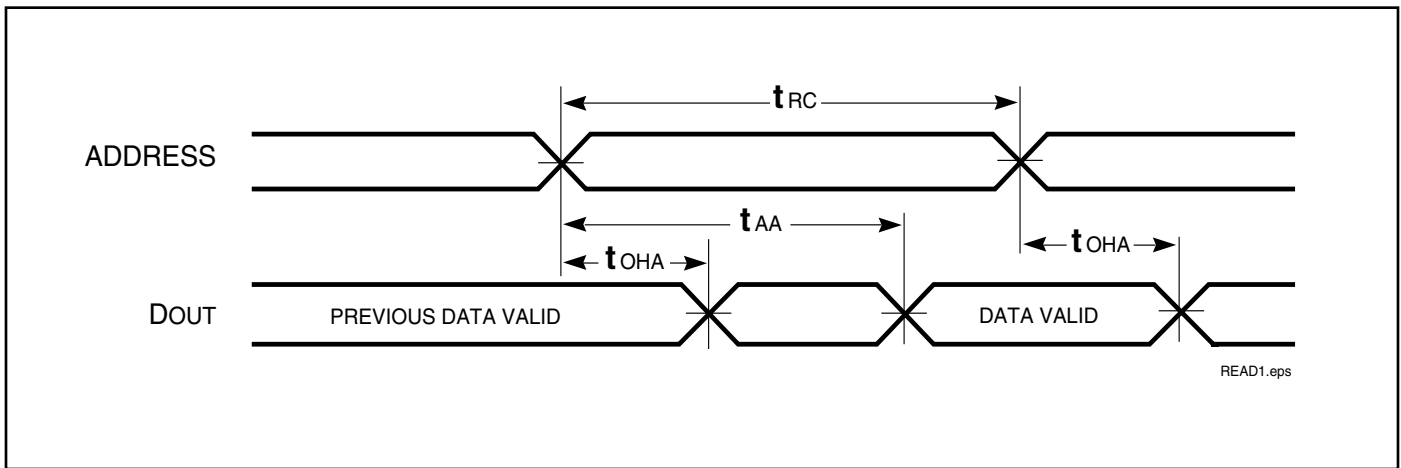

READ CYCLE NO. 2^(1,3) (\overline{CE} and \overline{OE} Controlled)

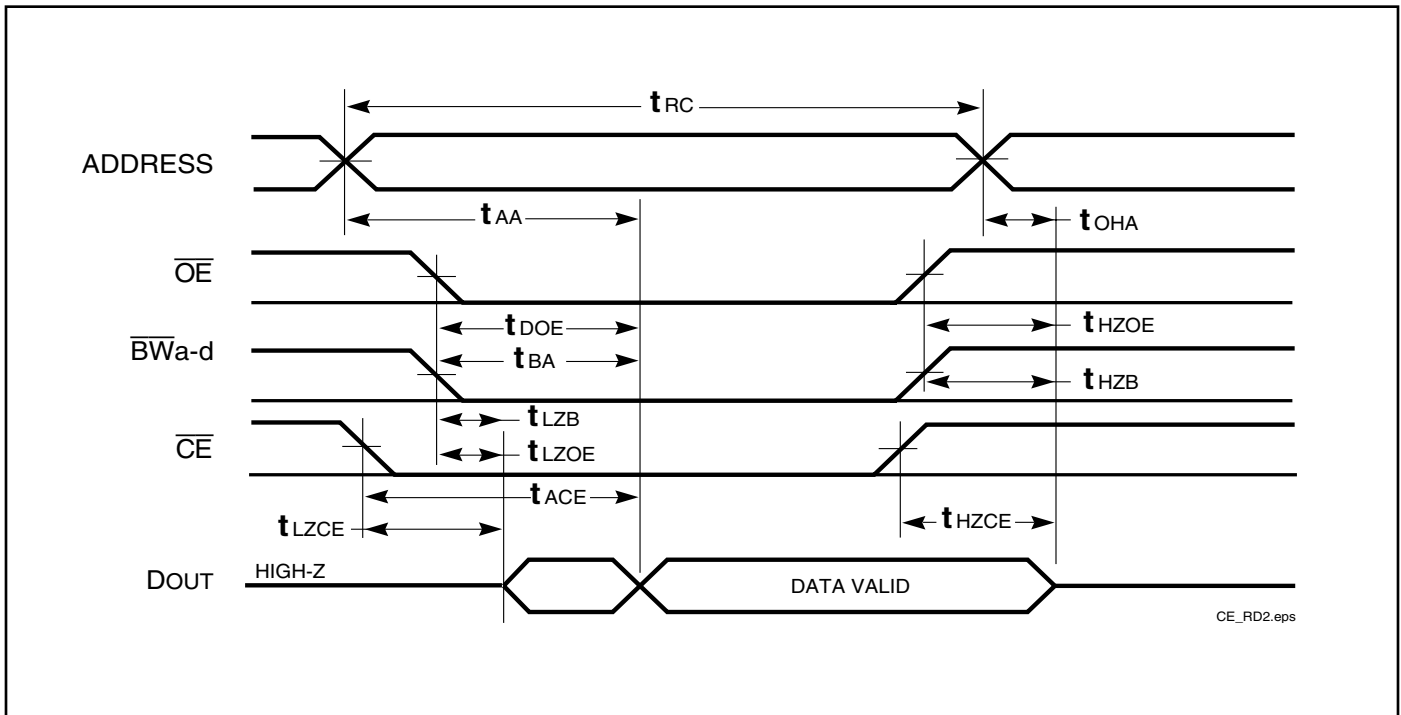

Notes:

1. \overline{WE} is HIGH for a Read Cycle.
2. The device is continuously selected. \overline{OE} , $\overline{CE} = V_{IL}$.
3. Address is valid prior to or coincident with \overline{CE} LOW transitions.

WRITE CYCLE SWITCHING CHARACTERISTICS^(1,3) (Over Operating Range)

Symbol	Parameter	-8		-10		Unit
		Min.	Max.	Min.	Max.	
t _{wc}	Write Cycle Time	8	—	10	—	ns
t _{sce}	\overline{CE} to Write End	6.5	—	8	—	ns
t _{aw}	Address Setup Time to Write End	6.5	—	8	—	ns
t _{ha}	Address Hold from Write End	0	—	0	—	ns
t _{sa}	Address Setup Time	0	—	0	—	ns
t _{pwb}	\overline{BWA} -d Valid to End of Write	6.5	—	8	—	ns
t _{pwe1}	\overline{WE} Pulse Width	6.5	—	8	—	ns
t _{pwe2}	\overline{WE} Pulse Width ($\overline{OE} = \text{LOW}$)	8.0	—	10	—	ns
t _{sd}	Data Setup to Write End	5	—	6	—	ns
t _{hd}	Data Hold from Write End	0	—	0	—	ns
t _{hzwe} ⁽²⁾	\overline{WE} LOW to High-Z Output	—	3.5	—	5	ns
t _{lzwe} ⁽²⁾	\overline{WE} HIGH to Low-Z Output	2	—	2	—	ns

Notes:

1. Test conditions assume signal transition times of 3 ns or less, timing reference levels of 1.5V, input pulse levels of 0V to 3.0V and output loading specified in Figure 1.
2. Tested with the load in Figure 2. Transition is measured ± 500 mV from steady-state voltage. Not 100% tested.
3. The internal write time is defined by the overlap of \overline{CE} LOW, and \overline{WE} LOW. All signals must be in valid states to initiate a Write, but any one can go inactive to terminate the Write. The Data Input Setup and Hold timing are referenced to the rising or falling edge of the signal that terminates the write. Shaded area product in development

WRITE CYCLE SWITCHING CHARACTERISTICS^(1,2) (Over Operating Range)

Symbol	Parameter	-20 ns		Unit
		Min.	Max.	
t _{wc}	Write Cycle Time	20	—	ns
t _{sce}	\overline{CE} to Write End	12	—	ns
t _{aw}	Address Setup Time to Write End	12	—	ns
t _{ha}	Address Hold from Write End	0	—	ns
t _{sa}	Address Setup Time	0	—	ns
t _{pwb}	\overline{BWA} -d Valid to End of Write	12	—	ns
t _{pwe1}	\overline{WE} Pulse Width (\overline{OE} = HIGH)	12	—	ns
t _{pwe2}	\overline{WE} Pulse Width (\overline{OE} = LOW)	17	—	ns
t _{sd}	Data Setup to Write End	9	—	ns
t _{hd}	Data Hold from Write End	0	—	ns
t _{hzwe} ⁽³⁾	\overline{WE} LOW to High-Z Output	—	9	ns
t _{lzwe} ⁽³⁾	\overline{WE} HIGH to Low-Z Output	3	—	ns

Notes:

1. Test conditions assume signal transition times of 3ns or less, timing reference levels of 1.5V, input pulse levels of 0V to 0.3V and output loading specified in Figure 1a.
2. Tested with the load in Figure 1b. Transition is measured ± 500 mV from steady-state voltage. Not 100% tested.
3. The internal write time is defined by the overlap of \overline{CE} LOW and \overline{WE} LOW. All signals must be in valid states to initiate a Write, but any one can go inactive to terminate the Write. The Data Input Setup and Hold timing are referenced to the rising or falling edge of the signal that terminates the write.

AC WAVEFORMS

WRITE CYCLE NO. 1^(1,2) (\overline{CE} Controlled, \overline{OE} = HIGH or LOW)

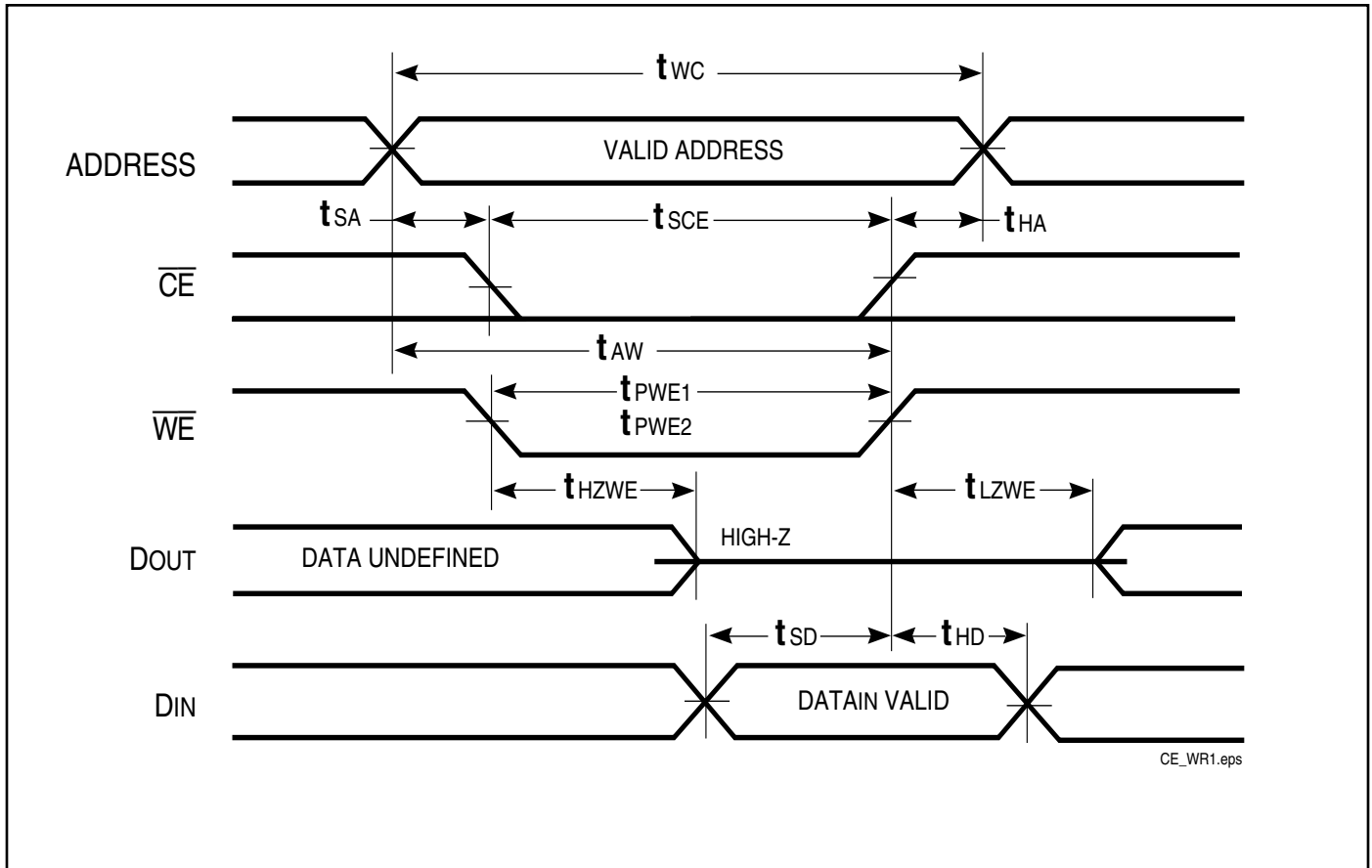

AC WAVEFORMS

WRITE CYCLE NO. 2 (\overline{WE} Controlled. \overline{OE} is HIGH During Write Cycle) ^(1,2)

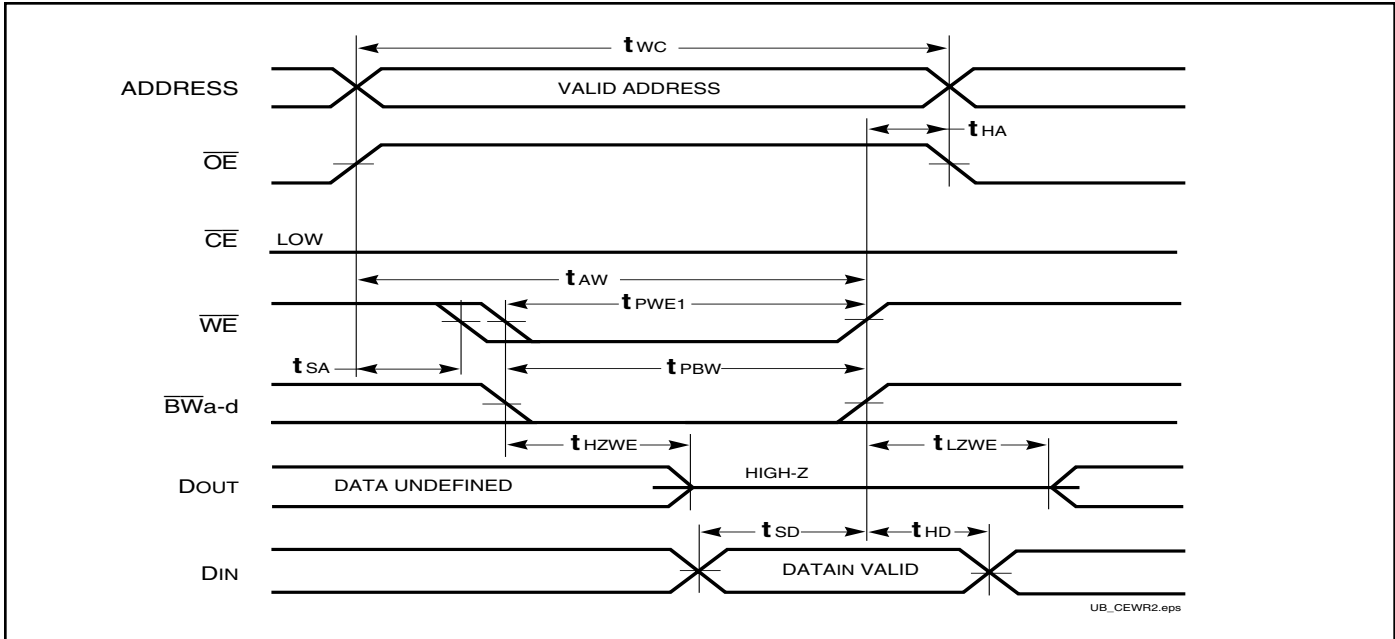

WRITE CYCLE NO. 3 (\overline{WE} Controlled. \overline{OE} is LOW During Write Cycle) ⁽¹⁾

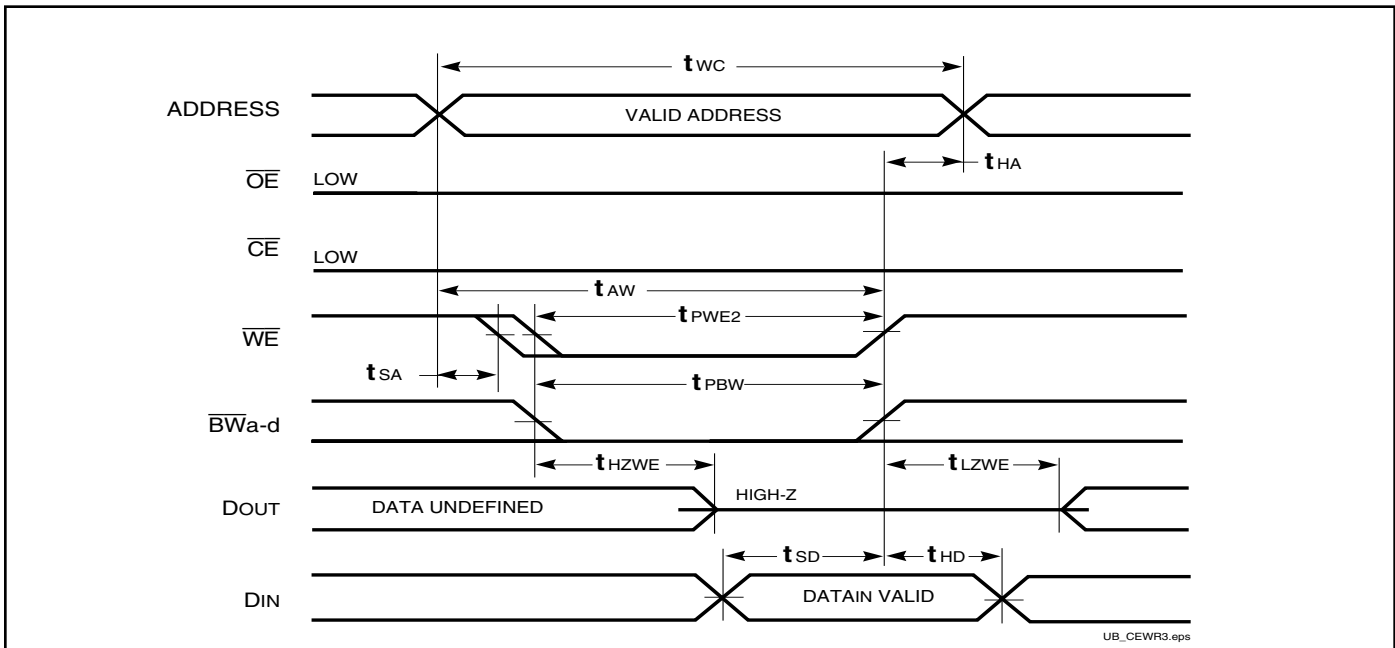

AC WAVEFORMS

WRITE CYCLE NO. 4 (Byte Controlled, Back-to-Back Write) ^(1,3)

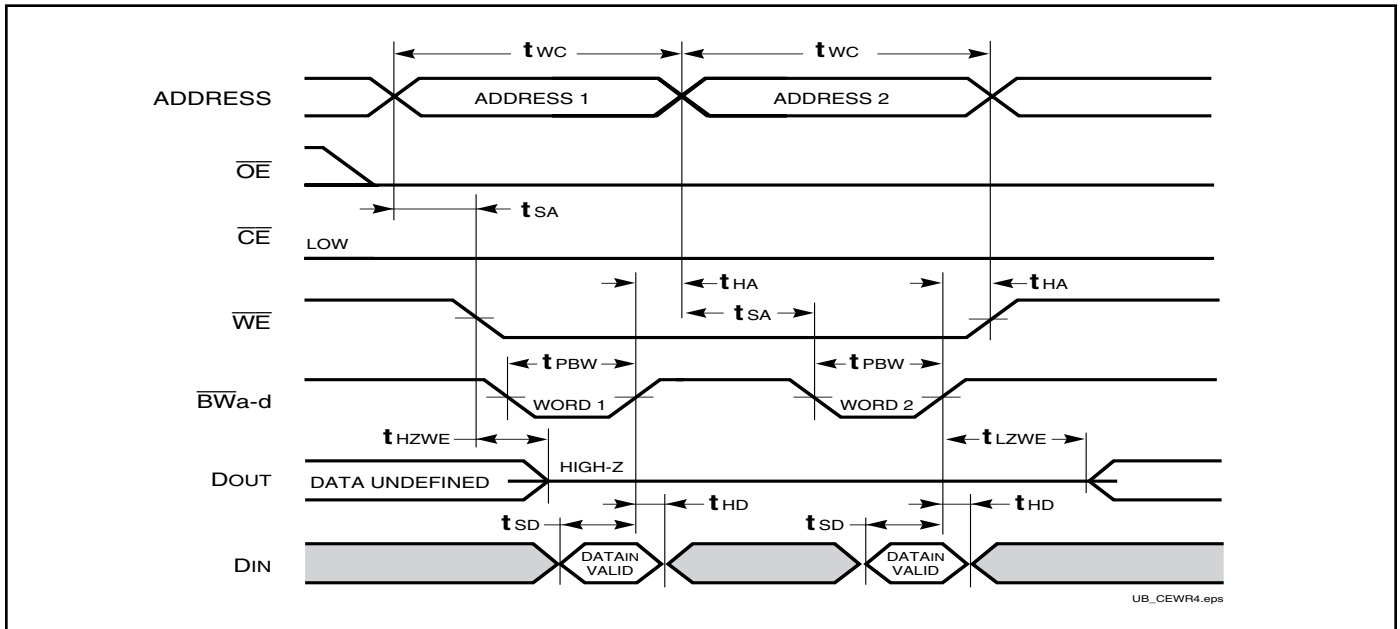

Notes:

1. The internal Write time is defined by the overlap of $\overline{WE} = \text{LOW}$. All signals must be in valid states to initiate a Write, but any can be deasserted to terminate the Write. The t_{SA} , t_{HA} , t_{SD} , and t_{HD} timing is referenced to the rising or falling edge of the signal that terminates the Write.
2. Tested with \overline{OE} HIGH for a minimum of 4 ns before $\overline{WE} = \text{LOW}$ to place the I/O in a HIGH-Z state.
3. \overline{WE} may be held LOW across many address cycles and the $\overline{BWA-d}$ pins can be used to control the Write function.

DATA RETENTION SWITCHING CHARACTERISTICS (HIGH SPEED) (IS61WV25632ALL/BLL)

Symbol	Parameter	Test Condition	Min.	Max.	Unit
V _{DR}	V _{DD} for Data Retention	See Data Retention Waveform	1.2	3.6	V
I _{DR}	Data Retention Current	V _{DD} = 1.2V, $\overline{CE} \geq V_{DD} - 0.2V$	—	25 60	mA
t _{SDR}	Data Retention Setup Time	See Data Retention Waveform	0	—	ns
t _{RDR}	Recovery Time	See Data Retention Waveform	t _{RC}	—	ns

DATA RETENTION WAVEFORM (\overline{CE} Controlled)

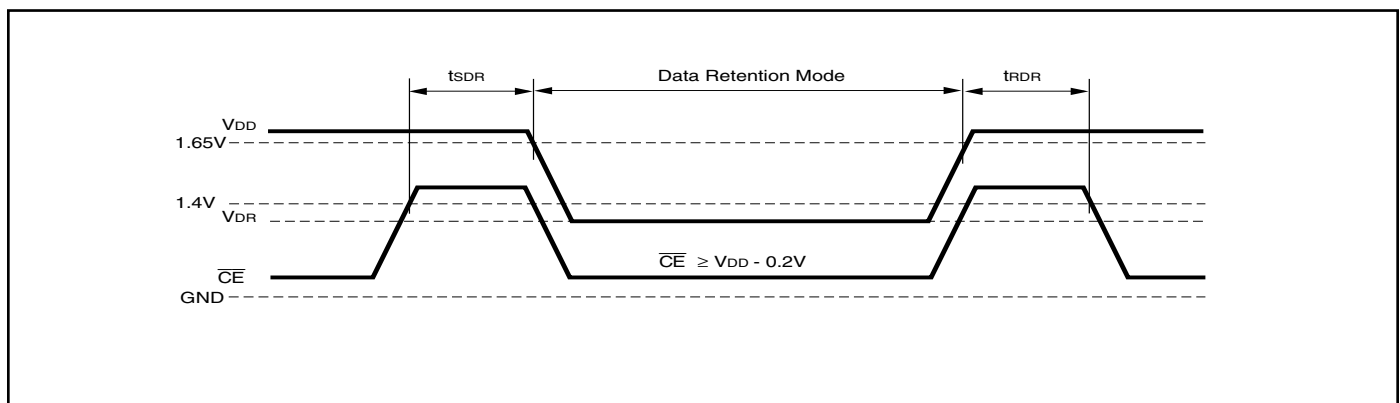

DATA RETENTION SWITCHING CHARACTERISTICS (LOW POWER) (IS61WV25632ALS/BLS)

Symbol	Parameter	Test Condition	Min.	Max.	Unit
V _{DR}	V _{DD} for Data Retention	See Data Retention Waveform	1.2	3.6	V
I _{DR}	Data Retention Current	V _{DD} = 1.2V, $\overline{CE} \geq V_{DD} - 0.2V$	—	1.2	mA
		Ind. Auto.	—	2	
t _{SDR}	Data Retention Setup Time	See Data Retention Waveform	0	—	ns
t _{RDR}	Recovery Time	See Data Retention Waveform	t _{RC}	—	ns

DATA RETENTION WAVEFORM (\overline{CE} Controlled)

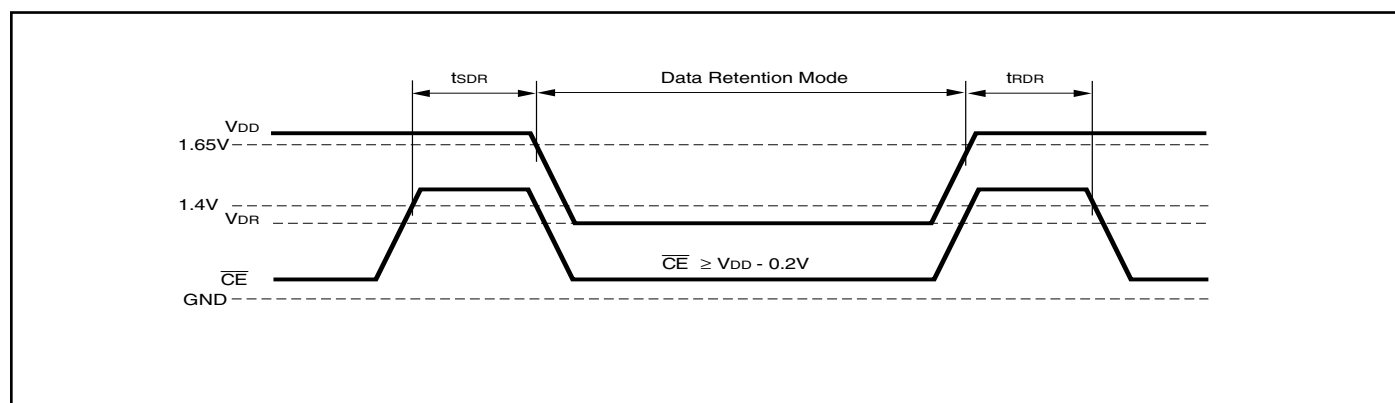

ORDERING INFORMATION

Industrial Range: -40°C to +85°C

Voltage Range: 2.4V to 3.6V

Speed (ns)	Order Part No.	Package
10 (8 ¹)	IS61WV25632BLL-10BLI	90-ball BGA (8mm x 13mm), Lead-free

Note:

1. Speed = 8ns for V_{DD} = 3.3V ± 5%. Speed = 10ns for V_{DD} = 2.4V - 3.6V

Industrial Range: -40°C to +85°C

Voltage Range: 1.65V to 2.2V

Speed (ns)	Order Part No.	Package
20	IS61WV25632ALL-20BLI	90-ball BGA (8mm x 13mm), Lead-free

Automotive Range: -40°C to +125°C

Voltage Range: 2.4V to 3.6V

Speed (ns)	Order Part No.	Package
10	IS64WV25632BLL-10BLA3	90-ball BGA (8mm x 13mm), Lead-free

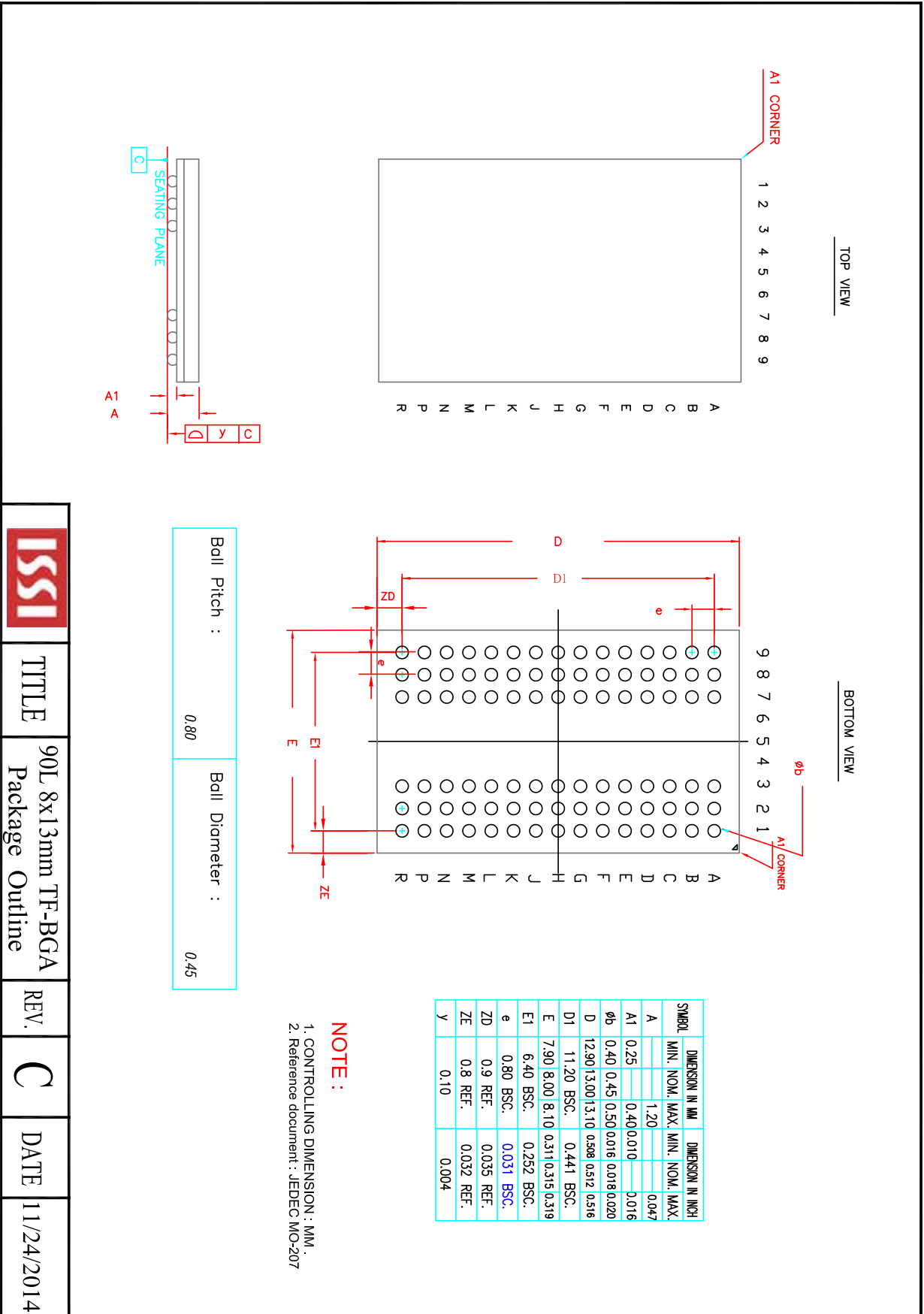

	TITLE	90L 8x13mm TF-BGA Package Outline	REV.	C	DATE	11/24/2014
--	-------	-----------------------------------	------	---	------	------------