

ISL24212

Programmable  $V_{COM}$  Calibrator with EEPROM and Output Buffer

FN7590  
Rev 0.00  
March 15, 2011

The ISL24212 is an 8-bit programmable current sink that can be used in conjunction with an external voltage divider to generate a voltage source ( $V_{COM}$ ) positioned between the analog supply voltage and ground. The current sink's full-scale range is controlled by an external resistor,  $R_{SET}$ . With the appropriate choice of external resistors  $R_1$  and  $R_2$ , the  $V_{COM}$  voltage range can be controlled between any arbitrary voltage range. The ISL24212 has an 8-bit data register and 8-bit EEPROM for storing both a volatile and a permanent value for its output, accessible through a single up/down counter interface pin (CTL). After the part is programmed with the desired  $V_{COM}$  value, the Counter Enable pin (CE) can be grounded to prevent further changes. On every power-up, the EEPROM contents are automatically transferred to the data register and the pre-programmed output voltage appears at the  $V_{COM\_OUT}$  pin.

The ISL24212 also features an integrated, wide-bandwidth, high output drive buffer amplifier that can directly drive the  $V_{COM}$  input of an LCD panel.

The ISL24212 is available in an 10 Ld 3mm x 3mm TDFN package. This package has a maximum height of 0.8mm for very low profile designs. The ambient operating temperature range is  $-40^{\circ}C$  to  $+85^{\circ}C$ .

**Features**

- Adjustable 8-bit, 256-Step, Current Sink Output
- 60MHz  $V_{COM}$  Buffer/Amplifier
- On-Chip 8-Bit EEPROM
- Up/Down Counter Interface
- Guaranteed Monotonic Over-Temperature
- 4.5V to 19.0V Analog Supply Range for Normal Operation (10.8V Minimum Analog Supply Voltage for Programming)
- 2.25V to 3.6V Logic Supply Voltage Operating Range
- Pb-free (RoHS-compliant)
- Ultra-Thin 10 Ld TDFN (3x3x0.8mm max)

**Applications**

- LCD Panel  $V_{COM}$  Generator
- Electrophoretic Display  $V_{COM}$  Generator

**Related Literature**

- See Application Note "ISL24212IRTZ-EVALZ Evaluation Board User Guide" (Coming Soon)

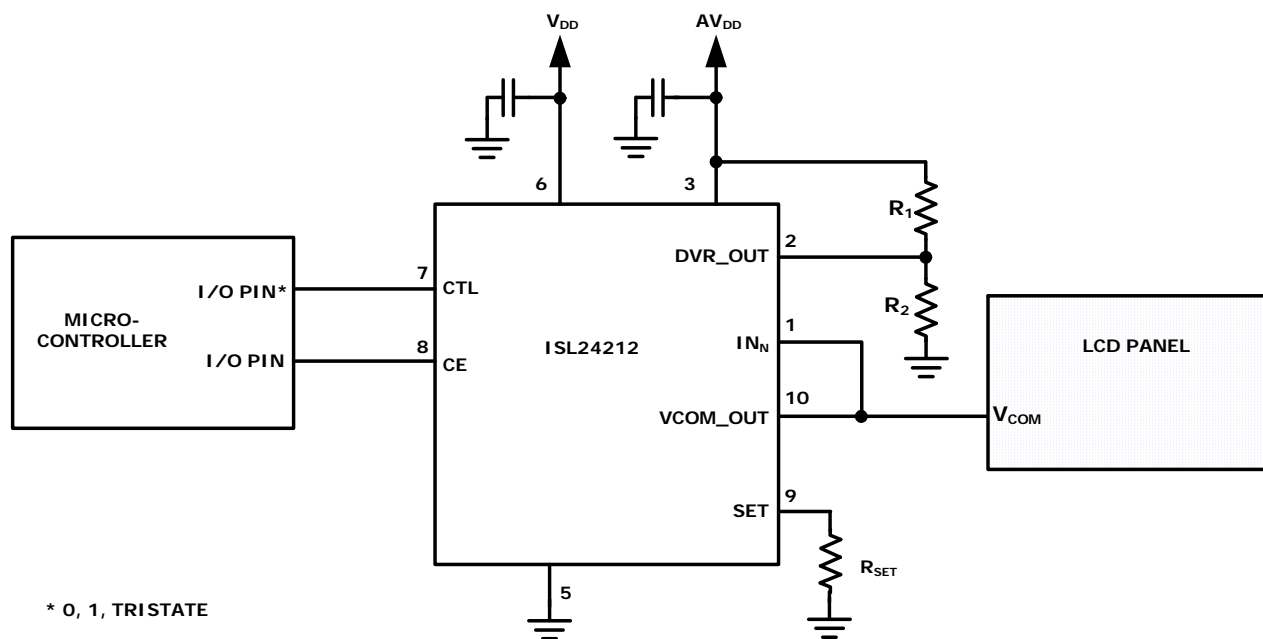

FIGURE 1. TYPICAL ISL24212 APPLICATION

## Block Diagram

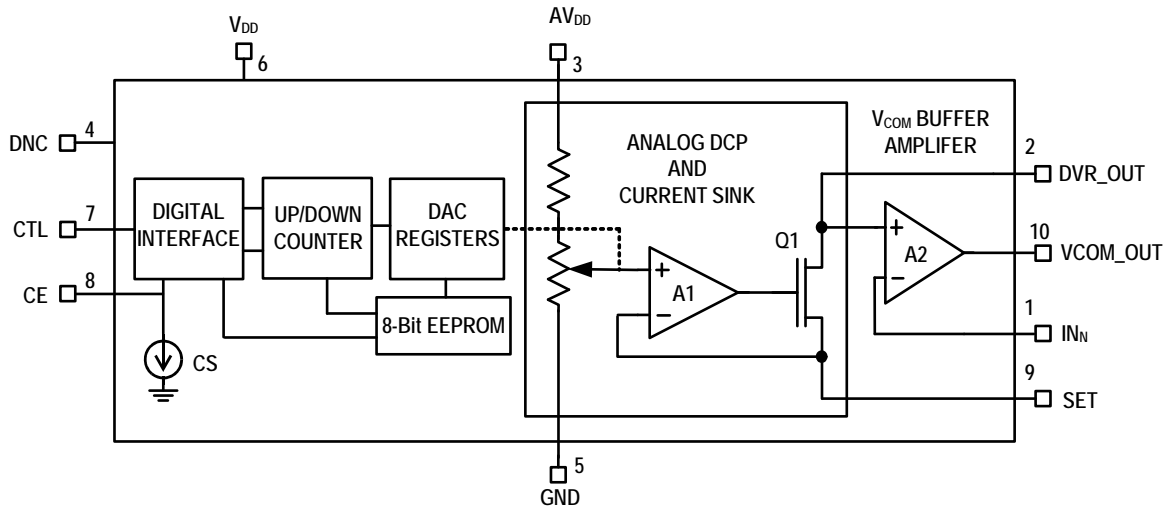
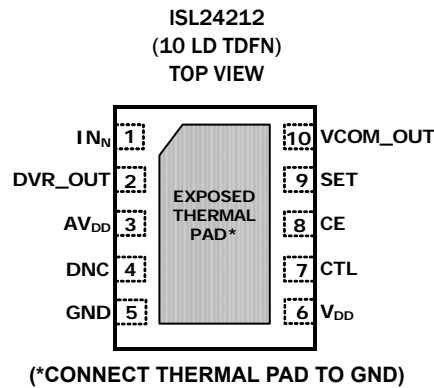

FIGURE 2. BLOCK DIAGRAM OF THE ISL24212

## Pin Configuration



## Pin Descriptions

PIN NAME	PIN NUMBER	FUNCTION
IN <sub>N</sub>	1	Negative input of the op amp. To create a unity-gain V <sub>COM</sub> voltage buffer, connect this pin to the VCOM_OUT pin.
DVR_OUT	2	Current Sink Output. The sink current into the DVR_OUT (Digital Variable Resistor) pin is equal to the DAC setting times the maximum adjustable sink current divided by 256. See the “SET” pin function description (pin 9) for setting the maximum adjustable sink current.
AV <sub>DD</sub>	3	High-Voltage Analog Supply. Bypass to GND with 0.1μF capacitor.
DNC	4	Do Not Connect to external circuitry. It is acceptable to ground this pin.
GND	5	Ground connection.
V <sub>DD</sub>	6	Digital power supply input. Bypass to GND with 0.1μF capacitor.
CTL	7	Up/Down Control for internal counter and Internal EEPROM Programming Control Input. When CE is high: A low-to-mid transition increments the 8-bit counter, adding 1 to the DAC setting, increasing the DVR_OUT sink current, and lowering the divider voltage at the DVR_OUT pin. A high-to-mid transition decrements the 8-bit counter, subtracting 1 from the DAC setting, decreasing the DVR_OUT sink current, and increasing the divider voltage at the DVR_OUT pin. To program the EEPROM, take this pin to >4.9V (see “CTL EEPROM Programming Signal Time” in the “Electrical Specification” table on page 5 for details). Float when not in use.

## Pin Descriptions (Continued)

PIN NAME	PIN NUMBER	FUNCTION
CE	8	Counter Enable Pin. Connect CE to $V_{DD}$ to enable adjustment of the output sink current. Float or connect CE to GND to prevent further adjustment or programming (Note: the CE pin has an internal 500nA pull-down sink current). The EEPROM value will be copied to the register on a $V_{OH}$ to $V_{OL}$ transition.
SET	9	Maximum Sink Current Adjustment Point. Connect a resistor from SET to GND to set the maximum adjustable sink current of the DVR_OUT pin. The maximum adjustable sink current is equal to $(AV_{DD}/20)$ divided by $R_{SET}$ .
VCOM_OUT	10	Output of the buffer amplifier
PAD	-	Thermal pad should be connected to system ground plane to optimize thermal performance.

## Ordering Information

PART NUMBER (Notes 1, 2, 3)	PART MARKING	INTERFACE	TEMP RANGE (°C)	PACKAGE (Pb-Free)	PKG. DWG. #
ISL24212IRTZ	4212	COUNTER	-40 to +85	10 Ld 3x3 TDFN	L10.3x3A
ISL24212IRTZ-EVALZ	Evaluation Board				

### NOTES:

1. Add "-T\*" suffix for tape and reel. Please refer to [TB347](#) for details on reel specifications.
2. These Intersil Pb-free plastic packaged products employ special Pb-free material sets, molding compounds/die attach materials, and 100% matte tin plate plus anneal (e3 termination finish, which is RoHS compliant and compatible with both SnPb and Pb-free soldering operations). Intersil Pb-free products are MSL classified at Pb-free peak reflow temperatures that meet or exceed the Pb-free requirements of IPC/JEDEC J STD-020.
3. For Moisture Sensitivity Level (MSL), please see device information page [ISL24212](#). For more information on MSL please see techbrief [TB363](#).

## Absolute Maximum Ratings

Supply Voltage	
AV <sub>DD</sub> to GND	20V
V <sub>DD</sub> to GND	4V
Input Voltage with respect to Ground	
SET, IN <sub>N</sub>	4V
SCL, SDA and $\overline{WP}$	V <sub>DD</sub> +0.3V
Output Voltage with respect to Ground	
DVR_OUT, VCOM_OUT	AV <sub>DD</sub>
Continuous Output Current	
DVR_OUT	5mA
VCOM_OUT	±100mA
ESD Ratings	
Human Body Model (Tested per JESD22-A114)	7kV
Machine Model (Tested per JESD22-A115)	250V
Charged Device Model (Tested per JESD22-C101)	2kV
Latch Up (Tested per JESD 78, Class II, Level A)	100mA

## Thermal Information

Thermal Resistance (Typical)	$\theta_{JA}$ (°C/W)	$\theta_{JC}$ (°C/W)
10 Ld TDFN Package (Notes 4, 5)	53	11
Moisture Sensitivity (see Technical Brief TB363)		
All Packages	Level 1	
Maximum Die Temperature	+150°C	
Storage Temperature	-65°C to +150°C	
Pb-free Reflow Profile	see link below	
	<a href="http://www.intersil.com/pbfree/Pb-FreeReflow.asp">http://www.intersil.com/pbfree/Pb-FreeReflow.asp</a>	

## Recommended Operating Conditions

Operating Range	
AV <sub>DD</sub>	4.5V to 19V
V <sub>DD</sub>	2.25V to 3.6V
Ambient Operating Temperature	-40°C to +85°C

**CAUTION:** Do not operate at or near the maximum ratings listed for extended periods of time. Exposure to such conditions may adversely impact product reliability and result in failures not covered by warranty.

### NOTES:

- $\theta_{JA}$  is measured in free air with the component mounted on a high effective thermal conductivity test board with "direct attach" features. See Tech Brief TB379.
- For  $\theta_{JC}$ , the "case temp" location is the center of the exposed metal pad on the package underside.

**Electrical Specifications** Test Conditions: V<sub>DD</sub> = 3.3V, AV<sub>DD</sub> = 18V, R<sub>SET</sub> = 5k $\Omega$ , R<sub>1</sub> = 10k $\Omega$ , R<sub>2</sub> = 10k $\Omega$ , (See Figure 5), VCOM\_OUT pin connected to IN<sub>N</sub>, unless otherwise specified. Typicals are at T<sub>A</sub> = +25°C. **Boldface limits apply over the operating temperature range, -40°C to +85°C.**

SYMBOL	PARAMETER	TEST CONDITIONS	MIN (Note 6)	TYP	MAX (Note 6)	UNITS
<b>DC CHARACTERISTICS</b>						
V <sub>DD</sub>	V <sub>DD</sub> Supply Range - Operating		<b>2.25</b>		<b>3.6</b>	V
AV <sub>DD</sub>	AV <sub>DD</sub> Supply Range Supporting EEPROM Programming		<b>10.8</b>		<b>19</b>	V
AV <sub>DD</sub>	AV <sub>DD</sub> Supply Range for Wide-Supply Operation without EEPROM Programming		<b>4.5</b>		<b>19</b>	V
I <sub>DD</sub>	V <sub>DD</sub> Supply Current	CTL = 0.5*V <sub>DD</sub>		95	300	$\mu$ A
I <sub>AVDD</sub>	AV <sub>DD</sub> Supply Current	CTL = 0.5*V <sub>DD</sub>		3.8	6.5	mA
<b>DVR_OUT CHARACTERISTICS</b>						
SET <sub>ZSE</sub>	SET Zero-Scale Error				±3	LSB
SET <sub>FSE</sub>	SET Full-Scale Error				±8	LSB
V <sub>DVR_OUT</sub>	DVR_OUT Voltage Range		<b>V<sub>SET</sub> + 1.75</b>		<b>AV<sub>DD</sub></b>	V
SET <sub>VD</sub>	SET Voltage Drift			7		$\mu$ V/°C
I <sub>DVR_OUT</sub>	Maximum DVR_OUT Sink Current			4		mA
INL	Integral Non-Linearity				±2	LSB
DNL	Differential Non-Linearity				±1	LSB
<b>OUTPUT AMPLIFIER CHARACTERISTICS</b>						
V <sub>OS</sub>	Input Offset Voltage			±2	±15	mV
TCV <sub>OS</sub>	Input Offset Voltage Drift			-6.3		$\mu$ V/°C
I <sub>B</sub>	Input Bias Current			±0.01	±1	$\mu$ A
CMRR	Common-Mode Rejection Ratio		55	75		dB
PSRR	Power Supply Rejection Ratio		60	82		dB
A <sub>VOL</sub>	Open Loop Gain		55	75		dB
V <sub>OL</sub>	Output Swing Low	I <sub>L</sub> = -5mA		50	<b>150</b>	mV

**Electrical Specifications** Test Conditions:  $V_{DD} = 3.3V$ ,  $AV_{DD} = 18V$ ,  $R_{SET} = 5k\Omega$ ,  $R_1 = 10k\Omega$ ,  $R_2 = 10k\Omega$ , (See Figure 5),  $V_{COM\_OUT}$  pin connected to  $IN_N$ , unless otherwise specified. Typical values are at  $T_A = +25^\circ C$ . **Boldface limits apply over the operating temperature range,  $-40^\circ C$  to  $+85^\circ C$ .** (Continued)

SYMBOL	PARAMETER	TEST CONDITIONS	MIN (Note 6)	TYP	MAX (Note 6)	UNITS
$V_{OH}$	Output Swing High	$I_L = 5mA$	<b>17.85</b>	17.9		V
$I_{SC}$	Short Circuit Current (Sinking)		300	430		mA
	Short Circuit Current (Sourcing)		450	555		mA
SR	Slew Rate (Rising)	$1K\Omega    8pF$ Load	70	116		V/ $\mu s$
	Slew Rate (Falling)	$1K\Omega    8pF$ Load	50	93		V/ $\mu s$
$t_s$	Settling Time to 0.2%			150		ns
BW	-3dB Bandwidth			60		MHz
<b>EEPROM CHARACTERISTICS</b>						
$t_{PROG}$	EEPROM Programming Time (internal)				100	ms
<b>UP/DOWN COUNTER CONTROL INPUTS (SEE FIGURE 11)</b>						
$V_{IH}$	CE and CTL Input Logic High Threshold		<b><math>0.7 \cdot V_{DD}</math></b>			V
$V_{IL}$	CE and CTL Input Logic Low Threshold				<b><math>0.3 \cdot V_{DD}</math></b>	V
$I_{CS\_PD}$	CE Input Pull Down Current Sink			0.5	<b>1.5</b>	$\mu A$
$I_{CTL}$	CTL Input Bias Current	CTL = GND (sourcing)		7	<b>15</b>	$\mu A$
		CTL = $V_{DD}$ (sinking)		7	<b>15</b>	$\mu A$
$t_{ST}$	CE to CTL Start Delay		<b>50</b>			$\mu s$
$t_{READ}$	EEPROM Recall Time (after CE de-asserted)				<b>10</b>	ms
$t_{H\_REJ}$	CTL High Pulse Rejection Width				<b>20</b>	$\mu s$
$t_{L\_REJ}$	CTL Low Pulse Rejection Width				<b>20</b>	$\mu s$
$t_{H\_MIN}$	CTL High Minimum Valid Pulse Width		<b>200</b>			$\mu s$
$t_{L\_MIN}$	CTL Low Minimum Valid Pulse Width		<b>200</b>			$\mu s$
$t_{MTC}$	CTL Minimum Time Between Counts		<b>10</b>			$\mu s$
$V_{PROG}$	CTL EEPROM Program Voltage (see Figure 9)		<b>4.9</b>		<b>19</b>	V
$t_{PROG}$	CTL EEPROM Programming Signal Time			200		$\mu s$
$t_{H\_PROP}$	CTL High-to-Mid to DVR_OUT propagation time			65		$\mu s$
$t_{L\_PROP}$	CTL Low-to-Mid to DVR_OUT propagation time			65		$\mu s$

NOTE:

6. Compliance to datasheet limits is assured by one or more methods: production test, characterization and/or design.

## Application Information

LCD panels have a  $V_{COM}$  (common voltage) that must be precisely set to minimize flicker. Figure 3 shows a typical  $V_{COM}$  adjustment circuit using a mechanical potentiometer, and the equivalent circuit replacement using the ISL24212. Having a digital counter interface enables automatic, digital flicker minimization during production test and alignment. After programming, the counter interface is no longer needed - the ISL24212 automatically powers up with the correct  $V_{COM}$  voltage programmed previously.

The ISL24212 uses a digitally controllable potentiometer (DCP), with 256 steps of resolution (see Figure 4) to change the current drawn at the DVR\_OUT pin, which then changes the voltage created by the  $R_1 - R_2$  resistor divider (see Figure 5). The DVR\_OUT voltage is then buffered by A2 to generate a buffered output voltage at the  $V_{COM\_OUT}$  pin, capable of directly driving the  $V_{COM}$  input of an LCD panel. The amount of current sunk is controlled by the setting of the DCP, which is recalled at power-up from the ISL24212's internal EEPROM. The EEPROM is typically programmed during panel manufacture. As noted in the "Electrical Specifications" on page 4, the ISL24212 requires a minimum  $AV_{DD}$  voltage of 10.8V for EEPROM programming, but will work in normal operation down to 4.5V after the EEPROM has been programmed, with no additional EEPROM writing.

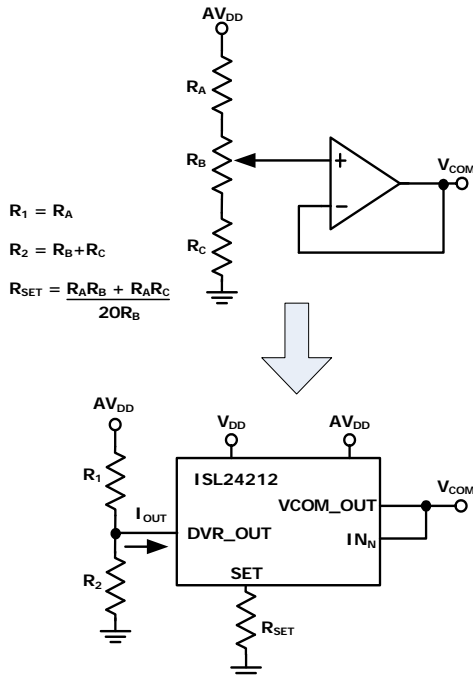

FIGURE 3. MECHANICAL ADJUSTMENT REPLACEMENT

### DCP (Digitally Controllable Potentiometer)

The DCP controls the voltage that ultimately controls the SET current. Figure 4 shows the relationship between the register value and the DCP's tap position. Note that a register value of 0 selects the first step of the resistor string. The output voltage of the DCP is given in Equation 1:

$$V_{DCP} = \left( \frac{\text{RegisterValue} + 1}{256} \right) \left( \frac{AV_{DD}}{20} \right) \quad (\text{EQ. 1})$$



FIGURE 4. SIMPLIFIED SCHEMATIC OF DCP

### Output Current Sink

Figure 5 shows the schematic of the DVR\_OUT current sink. The combination of amplifier A1, transistor Q1, and resistor  $R_{SET}$  forms a voltage-controlled current source, with the voltage determined by the DCP setting.

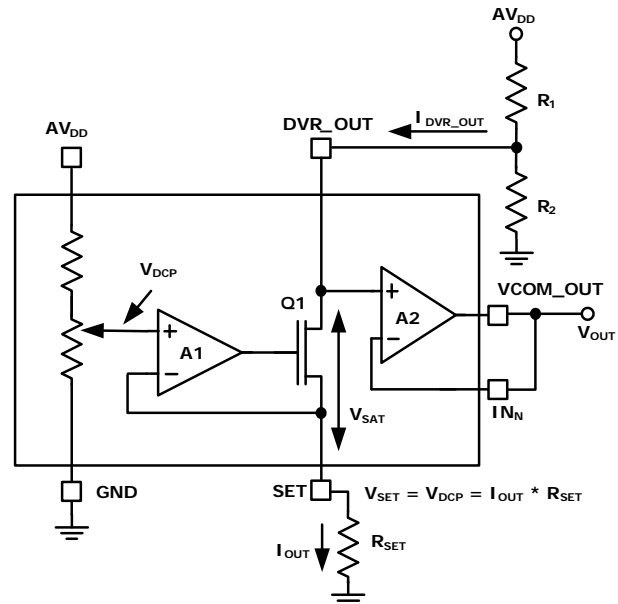

FIGURE 5. CURRENT SINK CIRCUIT

The external  $R_{SET}$  resistor sets the full-scale (maximum) sink current that can be pulled from the DVR\_OUT node. The relationship between  $I_{DVR\_OUT}$  and Register Value is shown in Equation 2.

$$I_{DVR\_OUT} = \frac{V_{DCP}}{R_{SET}} = \left( \frac{\text{RegisterValue} + 1}{256} \right) \left( \frac{AV_{DD}}{20} \right) \left( \frac{1}{R_{SET}} \right) \quad (\text{EQ. 2})$$

The maximum value of  $I_{DVR\_OUT}$  can be calculated by substituting the maximum register value of 255 into Equation 2, resulting in Equation 3:

$$I_{DVR\_OUT(MAX)} = \frac{AV_{DD}}{20R_{SET}} \quad (EQ. 3)$$

Equation 2 can also be used to calculate the unit sink current step size per Register Code, resulting in Equation 4:

$$I_{STEP} = \frac{AV_{DD}}{(256)(20)(R_{SET})} \quad (EQ. 4)$$

## Determination of $R_{SET}$

The ultimate goal for the ISL24212 is to generate an adjustable voltage between two endpoints,  $V_{COM\_MIN}$  and  $V_{COM\_MAX}$ , with a fixed power supply voltage,  $AV_{DD}$ . This is accomplished by choosing the correct values for  $R_{SET}$ ,  $R_1$  and  $R_2$ . The exact value of  $R_{SET}$  is not critical. Values from 1k to more than 100k will work under most conditions. Equation 5 calculates the minimum  $R_{SET}$  value:

$$R_{SET(MIN)} = \left( \frac{\frac{AV_{DD}}{16}}{\left( V_{OUT(MIN)} - \frac{AV_{DD}}{20} \right)} \right) (k\Omega) \quad (EQ. 5)$$

Note that this is the absolute minimum value for  $R_{SET}$ . Larger  $R_{SET}$  values reduce quiescent power, since  $R_1$  and  $R_2$  are proportional to  $R_{SET}$ . The ISL24212 is tested with a 5k $\Omega$   $R_{SET}$ .

## Determination of $R_1$ and $R_2$

With  $AV_{DD}$ ,  $V_{COM(MIN)}$  and  $V_{COM(MAX)}$  known and  $R_{SET}$  chosen per the above requirements,  $R_1$  and  $R_2$  can be determined using Equations 6 and 7:

$$R_1 = 5120 \cdot R_{SET} \left( \frac{V_{COM(MAX)} - V_{COM(MIN)}}{256 \cdot V_{COM(MAX)} - V_{COM(MIN)}} \right) \quad (EQ. 6)$$

$$R_2 = 5120 \cdot R_{SET} \left( \frac{V_{COM(MAX)} - V_{COM(MIN)}}{255 \cdot AV_{DD} + V_{COM(MIN)} - 256 \cdot V_{COM(MAX)}} \right) \quad (EQ. 7)$$

## Final Transfer Function

The voltage at the  $DVR\_OUT$  pin can be calculated from Equation 8:

$$V_{DVR\_OUT} = AV_{DD} \left( \frac{R_2}{R_1 + R_2} \right) \left( 1 - \frac{\text{RegisterValue} + 1}{256} \left( \frac{R_1}{20R_{SET}} \right) \right) \quad (EQ. 8)$$

With amplifier A2 in the unity-gain configuration ( $V_{COM\_OUT}$  tied to  $IN_N$  as shown in Figure 5),  $V_{DVR\_OUT} = V_{COM\_OUT} = V_{COM}$ .

## Example

As an example, suppose the  $AV_{DD}$  supply is 15V, the desired  $V_{COM\_MIN} = 6.5V$  and the desired  $V_{COM\_MAX} = 8.5V$ .  $R_{SET}$  is arbitrarily chosen to be 7.5k $\Omega$ .

First, verify that our chosen  $R_{SET}$  meets the minimum requirement described in Equation 5:

$$(7.5k\Omega) > \left( R_{SET(MIN)} = \left( \frac{\frac{15}{16}}{\left( 6.5V - \frac{15}{20} \right)} \right) = 0.163k\Omega \right) \quad (EQ. 9)$$

Using Equations 6 and 7, calculate the values of  $R_1$  and  $R_2$ :

$$R_1 = 5120 \cdot 7500 \cdot \left( \frac{8.5 - 6.5}{256 \cdot 8.5 - 6.5} \right) = 35.4k\Omega \quad (EQ. 10)$$

$$R_2 = 5120 \cdot 7500 \cdot \left( \frac{8.5 - 6.5}{255 \cdot 15 + 6.5 - 256 \cdot 8.5} \right) = 46.4k\Omega \quad (EQ. 11)$$

Table 1 shows the resulting  $V_{COM}$  voltage as a function of register value for these conditions.

TABLE 1. EXAMPLE  $V_{DVR\_OUT}$  vs REGISTER VALUE

REGISTER VALUE	$V_{DVR\_OUT}$ (V)
0	8.49
20	8.34
40	8.18
60	8.02
80	7.87
100	7.71
120	7.55
127	7.50
140	7.40
160	7.24
180	7.09
200	6.93
220	6.77
240	6.62
255	6.50

## Output Voltage Span Calculation

It is also possible to calculate  $V_{COM(MIN)}$  and  $V_{COM(MAX)}$  from the existing resistor values.

$V_{COM\_MIN}$  occurs when the greatest current,  $I_{DVR(MAX)}$ , is drawn from the middle node of the  $R_1/R_2$  divider. Substituting RegisterValue = 255 into Equation 8 gives the following:

$$V_{COM(MIN)} = AV_{DD} \left( \frac{R_2}{R_1 + R_2} \right) \left( 1 - \left( \frac{R_1}{20R_{SET}} \right) \right) \quad (EQ. 12)$$

Similarly, RegisterValue = 0 for  $V_{COM(MAX)}$ :

$$V_{COM(MAX)} = AV_{DD} \left( \frac{R_2}{R_1 + R_2} \right) \left( 1 - \frac{1}{256} \left( \frac{R_1}{20R_{SET}} \right) \right) \quad (EQ. 13)$$

By finding the difference of Equation 13 and Equation 12, the total span of  $V_{COM}$  can be found:

$$V_{COM}^{SPAN} = AV_{DD} \left( \frac{R_2}{R_1 + R_2} \right) \left( 1 - \frac{1}{256} \right) \left( \frac{R_1}{20R_{SET}} \right) \quad (EQ. 14)$$

Assuming that the  $I_{DVR_{OUT}(MIN)} = 0$  instead of  $I_{STEP}$ , the expression in Equation 14 simplifies to:

$$V_{COM}^{SPAN} = \left( \frac{R_1 \cdot R_2}{R_1 + R_2} \right) \left( \frac{AV_{DD}}{20R_{SET}} \right) = \left( \frac{R_1 \cdot R_2}{R_1 + R_2} \right) I_{DVR_{OUT}(MAX)} \quad (EQ. 15)$$

### DVR\_OUT Pin Leakage Current

When the voltage on the DVR\_OUT pin is greater than 10V, an additional leakage current flows into the pin in addition to the  $I_{SET}$  current. Figure 6 shows the  $I_{SET}$  current and the DVR\_OUT pin current for DVR\_OUT pin voltage up to 19V. In applications where the voltage on the DVR\_OUT pin will be greater than 10V, the actual output voltage will be lower than the voltage calculated by Equation 8 due to this extra current. The graph in Figure 6 was measured with  $R_{SET} = 4.99k\Omega$ .

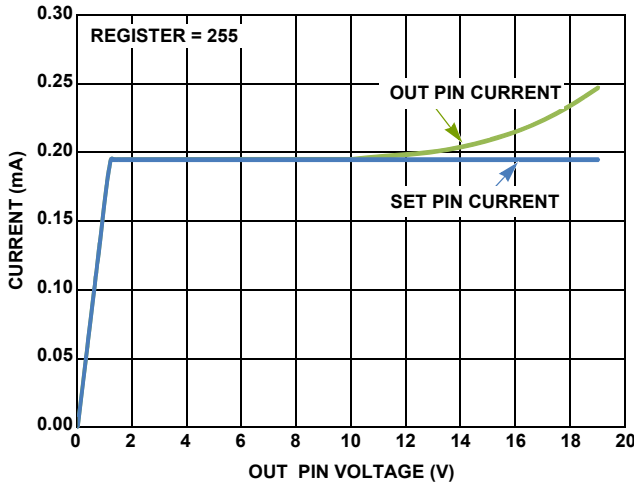

FIGURE 6. DVR\_OUT PIN LEAKAGE CURRENT

### Power Supply Sequence

The recommended power supply sequencing is shown in Figure 7. When applying power,  $V_{DD}$  should be applied before or at the same time as  $AV_{DD}$ . The minimum time for  $t_{VS}$  is 0μs. When removing power, the sequence of  $V_{DD}$  and  $AV_{DD}$  is not important.

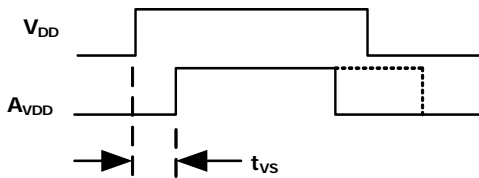

FIGURE 7. POWER SUPPLY SEQUENCE

Do not remove  $V_{DD}$  or  $AV_{DD}$  within 100ms of the start of the EEPROM programming cycle. Removing power before the EEPROM programming cycle is completed, may result in corrupted data in the EEPROM.

### Operating and Programming Supply Voltage and Current

To program the EEPROM,  $AV_{DD}$  must be  $\geq 10.8V$ . If further programming is not required, the ISL24212 will operate over an  $AV_{DD}$  range of 4.5V to 19V.

During EEPROM programming,  $I_{DD}$  and  $I_{AVDD}$  will temporarily be 4-5x higher for up to 100ms ( $t_{PROG}$ ).

### Up/Down Counter Interface

The ISL24212 allows the adjustment of the output  $V_{COM}$  voltage and the programming of the non-volatile memory through a single pin (CTL) when the CE (counter enable) pin is high. The CTL pin is biased so that its voltage is set to  $V_{DD}/2$  if the driving circuit is set to Tristate or High Impedance (Hi-Z), allowing up/down operation using common digital I/O logic.

#### CTL Pin

When a mid-high-mid transition is detected on the CTL pin (see Figure 11), the internal register value counts down by one at the trailing (high-mid) edge, and the output  $V_{COM}$  voltage is increased according to Equation 8. Similarly, when a mid-low-mid transition is detected on the CTL pin, the internal register value counts up by one at the trailing (low-mid) edge, and the output  $V_{COM}$  voltage is decreased. Once the maximum or minimum value is reached, the counter saturates and will not overflow or underflow beyond those values.

CTL should have a noise filter to reduce bouncing or noise on the input that could cause unwanted counts when the CE pin is high. Figure 8 shows a simple debouncing circuit consisting of a series 1kΩ resistor and a shunt 0.01μF capacitor connected on the CTL pin. To avoid unintentional adjustment, the ISL24212 guarantees to reject CTL pulses shorter than 20μs.

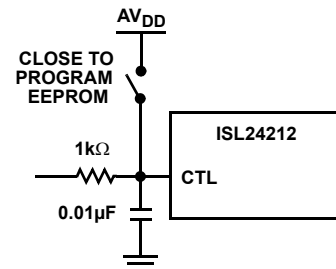

FIGURE 8. EXTERNAL DEBOUNCER ON CTL PIN

This pin is pulled above 4.9V to program the EEPROM. See “Programming the EEPROM” on page 9 for details.

After CE (Counter Enable) is asserted and after programming EEPROM, the very first CTL pulse is ignored (see Figure 11) to avoid the possibility of a false count (CTL state may be unknown after programming).



## CE Pin

To change the counter controlling the output voltage, the CE (Counter Enable) pin must be pulled high ( $V_{DD}$ ). When the CE pin is pulled low, the counter value is loaded from EEPROM, which takes 10ms (during which the inputs should remain constant). The CE pin has an internal pull-down to keep it at a logic low when not being driven. CE should be pulled low before powering the device down to ensure that any glitches or transients during power-down will not cause unwanted EEPROM overwriting.

The CE pin has a Schmitt trigger on the input to prevent false triggering during slow transitions of the CE pin. The CE pin transition time should be 10 $\mu$ s or less.

## Programming the EEPROM

To program the non-volatile EEPROM, pull the CTL pin above 4.9V for more than 200 $\mu$ s. The level and timing is shown in Figure 9. It then takes a maximum of 100ms after CTL crosses 4.9V for the programming to be completed inside the device.

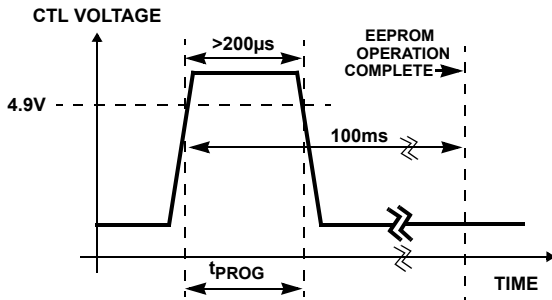

FIGURE 9. EEPROM PROGRAMMING

When the part is programmed, the data in the counter register is written into the EEPROM. This value will be loaded from the EEPROM during subsequent power-ups as well as when the CE pin is pulled low. The ISL24212 is factory-programmed to mid-scale. As with asserting CE, the first pulse after a program operation is ignored. The EEPROM contents can be written and verified using the following steps:

1. Power-up the ISL24212. The EEPROM value will be loaded.
2. Set the CE pin to  $V_{DD}$ .
3. Change the  $V_{OUT}$  voltage using the CTL pin to the desired value, noting that first pulse will be ignored.
4. Pull the CTL pin to 4.9V or higher for at least 200 $\mu$ s. The counter value will be written to EEPROM after 100ms.
5. Change the  $V_{OUT}$  value (using the CTL pin) to a different value, noting that first pulse after programming will be ignored.
6. Set the CE pin to 0V. The stored output value will be loaded from EEPROM after 10ms.
7. Verify that the output value is the same value programmed in Step 4.

The CTL pin should be left floating after programming. The voltage at the CTL pin will be internally biased to  $V_{DD}/2$  to ensure that no additional pulses will be seen by the Up/Down counter. To prevent further changes, ground the CE pin.

## Typical Application Circuit

Shown below in Figure 10 is a typical circuit that can be used to program the ISL24212 via the up/down counter interface. Three momentary push-button switches are required. SW1 connected between CTL and  $AV_{DD}$  allows the user to bring CTL above  $V_{DD}$  for programming the EEPROM, SW2 connected to  $V_{DD}$  to pull CTL up, and SW3 connected to GND to pull CTL to down. All the switches should have 1k $\Omega$  current-limiting resistors in series.

For adjustment and programming to occur, the CE pin has to be set to  $V_{DD}$ . This can be achieved by a single-pull double-throw switch (SW4) connected between  $V_{DD}$  and GND.

Note that pressing the UP button increments the counter, but results in  $V_{COM\_OUT}$  decreasing. Similarly, pressing the DOWN button decrements the counter, and results in  $V_{COM\_OUT}$  increasing.

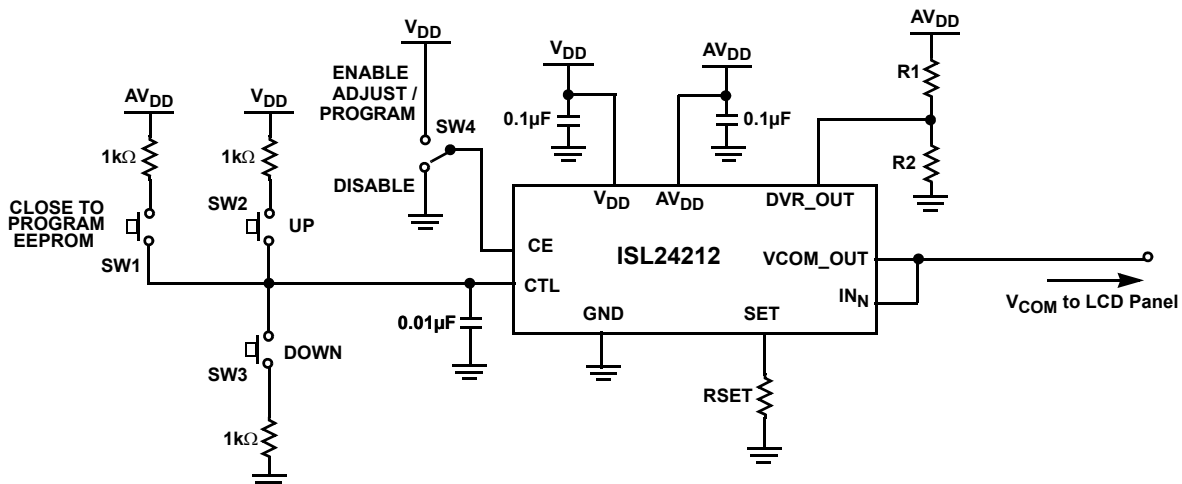

FIGURE 10. TYPICAL APPLICATION CIRCUIT

# Up/Down Counter Waveforms

The operation modes of the ISL24212 is shown in Table 2.

TABLE 2. ISL 24212 OPERATION MODES

INPUT		OUTPUT		
CTL	CE	COUNTER	V <sub>COM_OUT</sub>	EEPROM
X	Lo	No Change		
X	Lo to Hi	Ignore first CTL pulse		No Change
Hi to Mid	Hi	Decrement	Increase	No Change
Lo to Mid	Hi	Increment	Decrease	No Change
Mid to >4.9V	Hi	No Change	No Change	Write Counter Value to EEPROM
>4.9V to Mid	Hi	Ignore next CTL Pulse		No Change
X	Hi to Lo	EEPROM Read Value	Programmed Value	No Change

Figure 11 shows the associated waveforms.

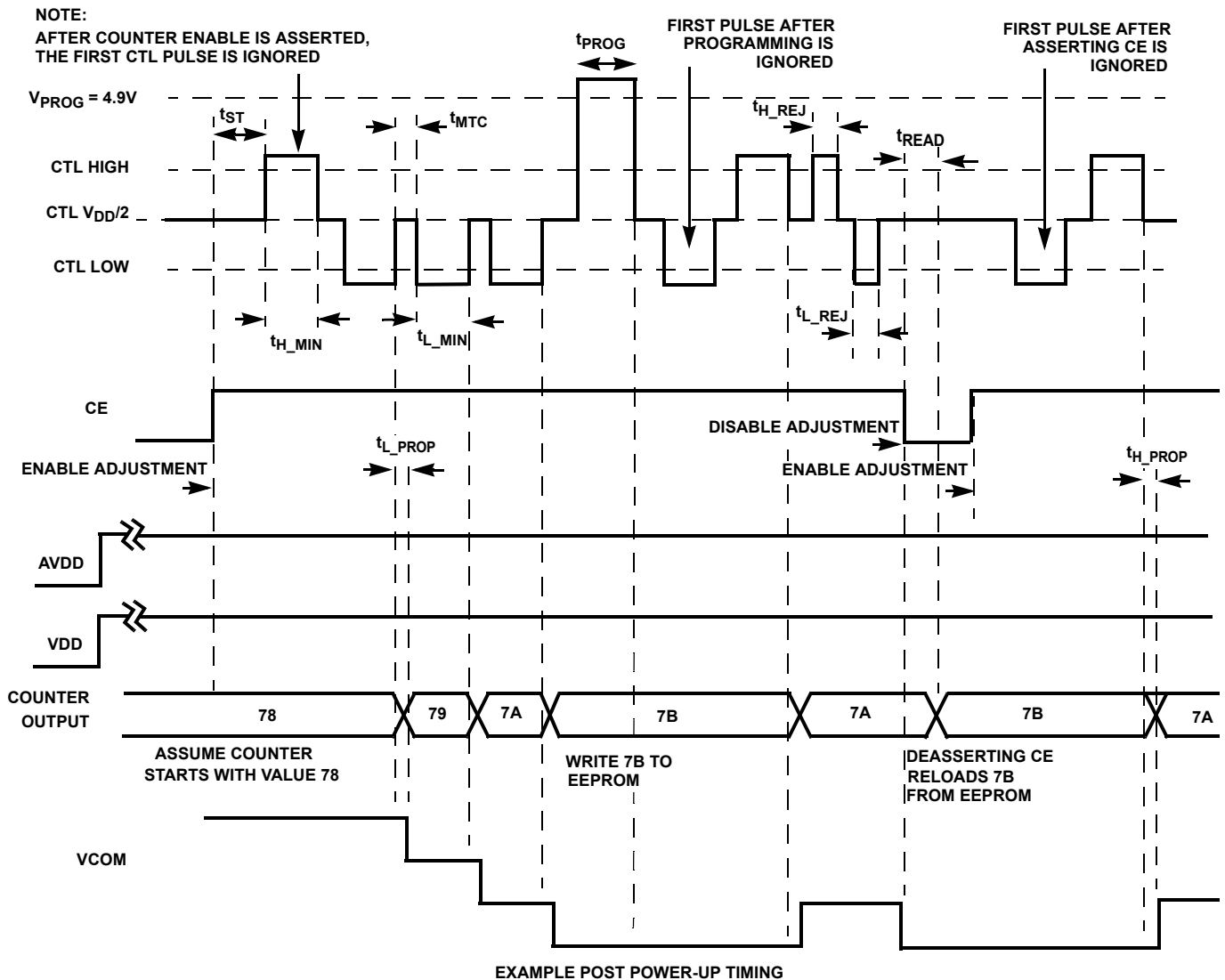

FIGURE 11. COUNTER INTERFACE TIMING DIAGRAM

## Revision History

The revision history provided is for informational purposes only and is believed to be accurate, but not warranted. Please go to web to make sure you have the latest revision.

DATE	REVISION	CHANGE
3/15/11	FN7590.0	Initial Release.

## Products

Intersil Corporation is a leader in the design and manufacture of high-performance analog semiconductors. The Company's products address some of the industry's fastest growing markets, such as, flat panel displays, cell phones, handheld products, and notebooks. Intersil's product families address power management and analog signal processing functions. Go to [www.intersil.com/products](http://www.intersil.com/products) for a complete list of Intersil product families.

\*For a complete listing of Applications, Related Documentation and Related Parts, please see the respective device information page on intersil.com: [ISL24212](http://www.intersil.com/ISL24212)

To report errors or suggestions for this datasheet, please go to [www.intersil.com/askourstaff](http://www.intersil.com/askourstaff)

FITs are available from our website at <http://rel.intersil.com/reports/search.php>

© Copyright Intersil Americas LLC 2011. All Rights Reserved.

All trademarks and registered trademarks are the property of their respective owners.

For additional products, see [www.intersil.com/en/products.html](http://www.intersil.com/en/products.html)

Intersil products are manufactured, assembled and tested utilizing ISO9001 quality systems as noted in the quality certifications found at [www.intersil.com/en/support/qualandreliability.html](http://www.intersil.com/en/support/qualandreliability.html)

*Intersil products are sold by description only. Intersil may modify the circuit design and/or specifications of products at any time without notice, provided that such modification does not, in Intersil's sole judgment, affect the form, fit or function of the product. Accordingly, the reader is cautioned to verify that datasheets are current before placing orders. Information furnished by Intersil is believed to be accurate and reliable. However, no responsibility is assumed by Intersil or its subsidiaries for its use; nor for any infringements of patents or other rights of third parties which may result from its use. No license is granted by implication or otherwise under any patent or patent rights of Intersil or its subsidiaries.*

For information regarding Intersil Corporation and its products, see [www.intersil.com](http://www.intersil.com)

# Package Outline Drawing

## L10.3x3A

10 LEAD THIN DUAL FLAT NO-LEAD PLASTIC PACKAGE

Rev 5, 3/10



TOP VIEW



BOTTOM VIEW



TYPICAL RECOMMENDED LAND PATTERN



SIDE VIEW

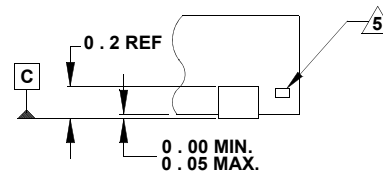

DETAIL "X"

**NOTES:**

1. Dimensions are in millimeters.  
Dimensions in ( ) for Reference Only.
2. Dimensioning and tolerancing conform to ASME Y14.5m-1994.
3. Unless otherwise specified, tolerance : Decimal  $\pm 0.05$   
Angular  $\pm 2.50^\circ$
4. Dimension applies to the metallized terminal and is measured between 0.15mm and 0.30mm from the terminal tip.
5. Tiebar shown (if present) is a non-functional feature.
6. The configuration of the pin #1 identifier is optional, but must be located within the zone indicated. The pin #1 identifier may be either a mold or mark feature.
7. Compliant to JEDEC MO-229-WEED-3 except exposed pad length (2.30mm).