

**Direct Conversion Transceiver**



The Intersil ISL3680 is a highly integrated UHF2 process, direct conversion transceiver and is part of a 2.4GHz, IEEE802.11b/g compliant radio chipset. The ISL3680 directly interfaces with Intersil's ISL3880 Medium Access Controller with Integrated Baseband processor. The addition of Intersil's ISL3980 power amplifier and ISL3090 10GHz VCO completes a WLAN transceiver application.

**Pinout**

**ISL3680 (QFN)  
TOP VIEW**

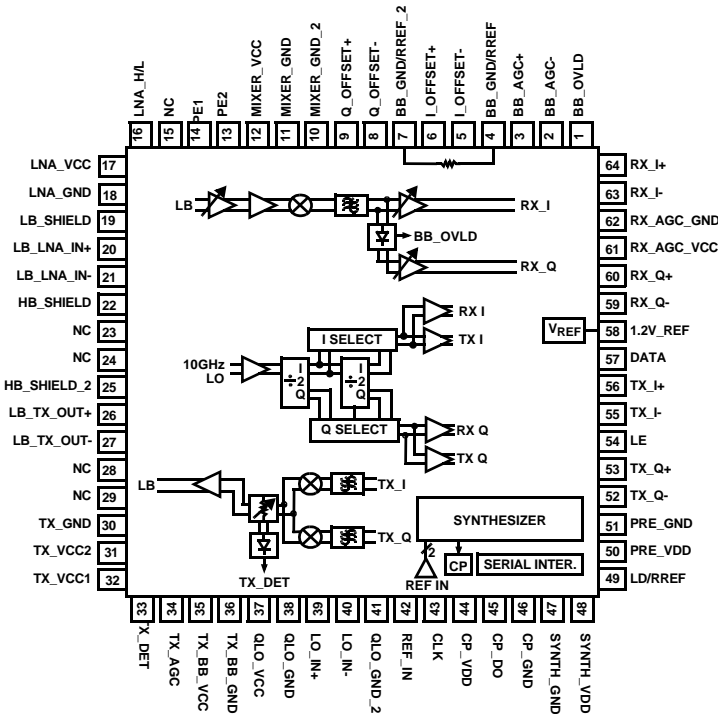

**Features**

- Highly integrated Dual Band RF to baseband solution
- Frequency of operation . . . . . 2.4 to 2.5GHz
- Low supply operation . . . . . 2.7 to 3.3V
- Noise figure . . . . . 5.4dB
- TX OFDM Output Power . . . . . -5dBm
- TX I/Q MTPR, PAR=12 . . . . . -45dB
- RX Voltage gain . . . . . 0 to 74dB
- RX I/Q MTPR, PAR=12, High Gain . . . . . -35dB
- TX/RX switching speed . . . . . <1μS
- Direct simple interface to ISL3880

**MLFP Package**

- Compliant to JEDEC PUB95 MO-220 QFN - Quad Flat No Leads - Package Outline
- Near Chip Scale Package footprint, which improves PCB efficiency and has a thinner profile

**Applications**

- PC card wireless LAN adapters
- High data rate wireless LAN systems targeting IEEE802.11 b/g standards
- Spread spectrum Dual Band WLAN RF modems
- TDMA or CSMA packet protocol Dual Band radios
- PCI wireless LAN cards
- ISA, ISA PnP WLAN cards

**Ordering Information**

PART NUMBER	TEMP. RANGE (°C)	PACKAGE	PKG.NO.
ISL3680IR	-40 to 85	64 Ld QFN	L64.9x9
ISL3680IR-TK	Tape and Reel		