

### Li-ion/Li Polymer Linear Battery Charger

The ISL6291 provides a low-cost integrated charger solution for single-cell Li-ion and Li Polymer rechargeable batteries. No external pass element, current sensing resistor, or reverse blocking diode is required with this solution.

The ISL6291 is a constant-current (CC)/constant-voltage (CV) charger. The constant charge current is programmable up to 2.0A with an external signal resistor. An internal trimmed current-sense circuit guarantees 10% accuracy, with no bulky external current-sense resistor. The constant voltage is either 4.1V or 4.2V. The charger always preconditions the battery with 1/10 of the programmed charge current at the beginning of a charge cycle, until it verifies that the battery can be fast-charged. A safety timer prevents over-charging a dead battery. The charging terminates as the charge current falls below the programmed minimum current during the CV mode. The charger automatically re-charges the battery when the battery voltage drops below a recharge threshold. A simple interface with an NTC thermistor avoids charging the battery outside a programmable temperature window. A thermal-foldback feature of the ISL6291 guarantees safe operation when the printed circuit board space is limited for thermal dissipation. The charger reduces the charge current automatically, as the internal temperature rises above a preset level, to prevent further temperature rise.

When the wall adapter is not present, the ISL6291 draws less than 1µA current from the battery. Two logic outputs provide the charging status and fault information, and an easy interface to system logic. A V2P8 pin outputs a 2.8V reference voltage that can be used to bias other circuits, or as an indication for the adapter presence.

The ISL6291 is packed in a thermally enhanced 5x5 QFN package. See the Technical Brief TB389 given in the Related Literature for more information related to the package.

### Features

- Integrated Linear Pass Element
- Integrated Charge Current Sensor
- No External Reverse Blocking Diode Required
- 1% Voltage Accuracy
- Programmable Current Limit Up to 2.0A
- Programmable End-of-Charge Current
- Trickle Charge an Over Discharged Battery
- Charge Current Thermal Foldback
- Simple Interface for Low-Cost Thermistor
- Accepts USB Bus Power
- Ambient Temperature Range: -20°C to 70°C
- Thermally-Enhanced 5x5 QFN Package ( $\theta_{JA} = 33^{\circ}\text{C/W}$ )
- Pb-Free Available (RoHS Compliant)

### Applications

- Handheld Devices
- Cell Phones
- PDAs
- Stand-Alone Chargers
- USB Bus-Powered Chargers

### Related Literature

- Technical Brief TB363 "Guidelines for Handling and Processing Moisture Sensitive Surface Mount Devices (SMDs)"
- Technical Brief TB389 "PCB Land Pattern Design and Surface Mount Guidelines for QFN Packages"

### Pinout

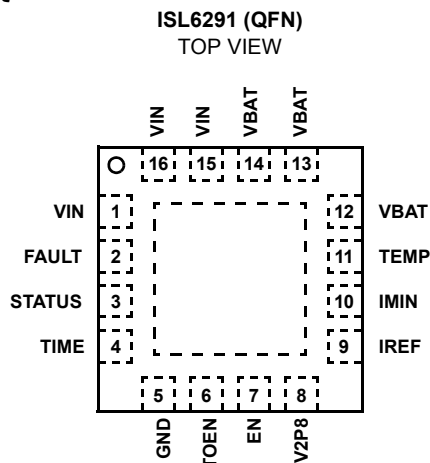

**Ordering Information**

PART NUMBER	TEMP. RANGE (°C)	PACKAGE	PKG. DWG. #
ISL6291-1CR	-20 to 70	16 Ld 5x5 QFN	L16.5x5B
ISL6291-1CRZ (See Note)	-20 to 70	16 Ld 5x5 QFN (Pb-free)	L16.5x5B
ISL6291-2CR	-20 to 70	16 Ld 5x5 QFN	L16.5x5B
ISL6291-2CRZ (See Note)	-20 to 70	16 Ld 5x5 QFN (Pb-free)	L16.5x5B
ISL6291-2CR- TR5155	-20 to 70	16 Ld 5x5 QFN	L16.5x5B
ISL6291-2CRZ- TR5155 (See Note)	-20 to 70	16 Ld 5x5 QFN (Pb-free)	L16.5x5B
ISL6291EVAL1	Evaluation Board		

\*Add "-T" suffix to part number for tape and reel packaging.

NOTE: Intersil Pb-free products employ special Pb-free material sets; molding compounds/die attach materials and 100% matte tin plate termination finish, which are RoHS compliant and compatible with both SnPb and Pb-free soldering operations. Intersil Pb-free products are MSL classified at Pb-free peak reflow temperatures that meet or exceed the Pb-free requirements of IPC/JEDEC J STD-020.

Block Diagrams

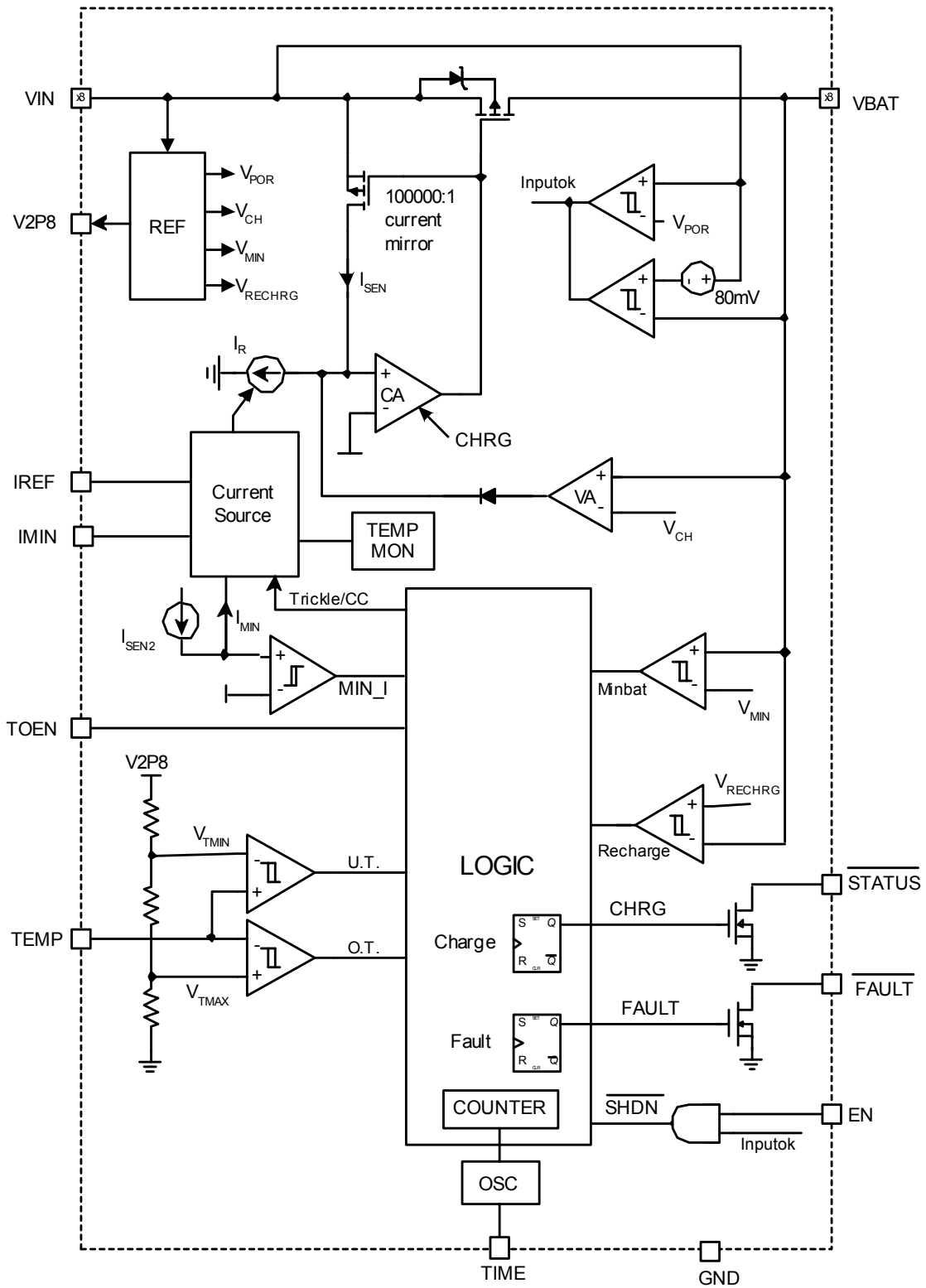

Typical Application

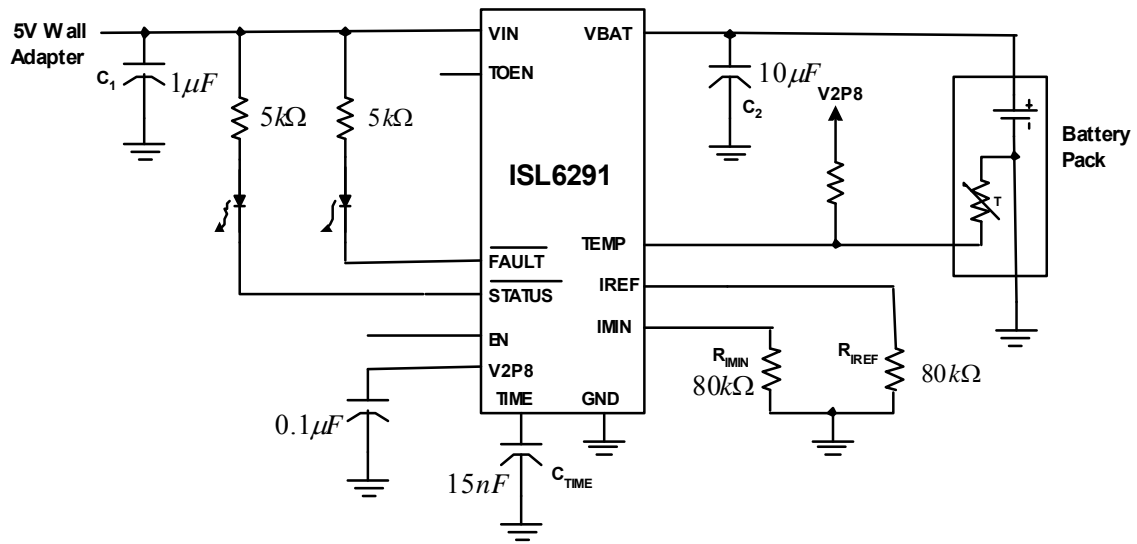

**Absolute Maximum Ratings**

Supply Voltage (VIN) .....	13.5V
Signal Input Voltage (EN, TOEN) .....	3.3V
ESD Rating	
Human Body Model (Per MIL-STD-883 Method 3015.7) .....	1kV
Machine Model (Per EIAJ ED-4701 Method C-111) .....	200V

**Recommended Operating Conditions**

Ambient Temperature Range .....	-20°C to 70°C
Supply Voltage, VIN .....	4.35V to 10V

**CAUTION:** Stresses above those listed in "Absolute Maximum Ratings" may cause permanent damage to the device. This is a stress only rating and operation of the device at these or any other conditions above those indicated in the operational sections of this specification is not implied.

**NOTE:**

1.  $\theta_{JA}$  is measured in free air with the component mounted on a high effective thermal conductivity test board with "direct attach" features. See Tech Brief TB379.
2. For  $\theta_{JC}$ , the "case temp" location is the center of the exposed metal pad on the package underside.

**Electrical Specifications** Typical Values Are Tested at 25°C and 5V Input, Maximum and Minimum Values Are Guaranteed Over 0°C to 70°C Ambient Temperature with a Supply Voltage in the Range of 4.35V to 10V, Unless Otherwise Noted.

PARAMETER	SYMBOL	TEST CONDITIONS	MIN	TYP	MAX	UNITS
<b>POWER-ON RESET</b>						
Rising VIN Threshold			-	3.9	4.3	V
Hysteresis			-	160	-	mV
<b>STANDBY CURRENT</b>						
VBAT Pin Sink Current	I <sub>STANDBY</sub>	VIN < VBAT	-	-	1	μA
VIN Pin Supply Current	I <sub>VIN</sub>	VIN > VBAT and EN = floating	-	1	-	mA
<b>VOLTAGE REGULATION</b>						
Output Voltage	V <sub>CH</sub>	ISL6291-1	4.059	4.10	4.141	V
Output Voltage	V <sub>CH</sub>	ISL6291-2	4.158	4.20	4.242	V
Dropout Voltage (Note 3)	V <sub>DROP</sub>	VBAT = 4.2V, charge current = 0.5A	-	-	250	mV
<b>CHARGE CURRENT</b>						
Constant Charge Current (Note 4)	I <sub>CHARGE</sub>	R <sub>IREF</sub> = 80kΩ, VBAT = V <sub>CH</sub> - 100mV	0.9	1.0	1.1	A
Trickle Charge Current	I <sub>TRICKLE</sub>		-	100	-	mA
End-of-Charge Threshold	I <sub>EOC</sub>	R <sub>IMIN</sub> pin = 80kΩ	-	100	-	mA
<b>RECHARGE THRESHOLD</b>						
Recharge Voltage Threshold	V <sub>RECHRG</sub>	ISL6291-2	-	4.00	-	V
Recharge Voltage Threshold	V <sub>RECHRG</sub>	ISL6291-1	-	3.90	-	V
<b>TRICKLE CHARGE THRESHOLD</b>						
Trickle Charge Threshold Voltage	V <sub>MIN</sub>		-	3.0	-	V
<b>TEMPERATURE MONITORING</b>						
Low Battery Temperature Threshold	V <sub>TMIN</sub>	V2P8 = 3V	1.425	1.505	1.575	V
High Battery Temperature Threshold	V <sub>TMAX</sub>		.260	.305	.340	V
Battery Removal Threshold	V <sub>RMV</sub>		-	2.25	-	V
Charge Current Foldback Threshold (Note 3)	T <sub>FOLD</sub>		85	100	115	°C
Current Foldback Gain	G <sub>FOLD</sub>		-	40	-	mA/°C
<b>OSCILLATOR</b>						
Oscillation Period		C <sub>TIME</sub> = 15nF	2.1	3	3.9	ms
<b>LOGIC INPUT AND OUTPUT</b>						
Logic Input High			2.0	-	-	V
Logic Input Low			-	-	0.8	V
STATUS/FAULT Sink Current		Pin Voltage = 0.8V	5	-	-	mA

**NOTES:**

3. Guaranteed by design, not tested.
4. The actual current may be affected by the thermal fold-back or the dropout voltage.

## Functional Pin Description

### VIN (Pin 1, 15, 16)

VIN is the input power source pin that is connected to a wall adapter.

### FAULT (Pin 2)

FAULT is an open-drain output indicating fault status. When a fault condition occurs, this pin is pulled to LOW.

### STATUS (Pin 3)

STATUS is an open-drain output indicating charging and inhibit states. During any charge mode, this pin is pulled to LOW.

### TIME (Pin 4)

Connect a timing capacitor  $C_{TIME}$  between this pin and GND. The internal oscillator, as shown in the Block Diagram, charges and discharges the timing capacitor between 0.5V and 1.5V with 10 $\mu$ A current. The oscillation period can be found as:

$$T_{OSC} = 0.2 \cdot 10^6 \cdot C_{TIME} \quad (\text{seconds})$$

A 22-stage binary counter increments each oscillation period to set up the TIMEOUT interval. The TIMEOUT interval can be calculated as:

$$TIMEOUT = 2^{22} \cdot T_{OSC} = 14 \cdot \frac{C_{TIME}}{1nF} \quad (\text{minutes})$$

When the fast charge takes longer than the TIMEOUT interval, or the Trickle charge time exceeds 1/8 of the TIMEOUT interval, the charger issues a TIMEOUT fault status and stops charging.

The oscillator also provides a time reference for the charger.

### GND (Pin 5)

GND is the connection to system ground.

### TOEN (Pin 6)

TOEN is the TIMEOUT enable input pin. Pulling this pin to LOW disables the TIMEOUT charge-time limit for the fast charge modes. Leave this pin floating to enable the TIMEOUT limit. An internal 10 $\mu$ A pull-up circuit pulls this pin up to a 2.8V internal reference. The trickle mode always has the 1/8 TIMEOUT limited charge time regardless of this input. When a TIMEOUT fault is issued, the charger is latched. The only way to enable the charger again is to cycle the input power, or to toggle the EN pin.

### EN (Pin 7)

EN is the CMOS logic input. Leave this pin floating to enable the charger. This pin is pulled up to the internal 2.8V reference via a 10 $\mu$ A current source.

### V2P8 (Pin 8)

V2P8 is a 2.8V reference voltage output. V2P8 pin outputs a 2.8V voltage when the input voltage rises above the POR threshold and outputs zero voltage otherwise. This pin can be used as an adapter presence signal. A 0.1 $\mu$ F Ceramic capacitor is recommended for decoupling purposes. This pin can be used to bias other circuits with a maximum current of 2mA.

### IREF (Pin 9)

IREF is the programming input for the constant charge current. Connect a resistor  $R_{IREF}$  (see the Typical Application) to this pin. The voltage of this pin is regulated to a 0.8V reference voltage. The charging current during the constant current mode charge is 100,000 times of the current in the  $R_{IREF}$  resistor. The charging current in the constant current mode can be found as:

$$I_{REF} = 100000 \cdot \frac{V_{REF}}{R_{IREF}} = \frac{0.8V}{R_{IREF}} \times 10^5 (A)$$

where  $V_{REF}$  is the 0.8V reference voltage.

### IMIN (Pin 10)

IMIN is a programmable input for the end-of-charge current. The pin voltage is also regulated at 0.8V. The end-of-charge current can be found as:

$$I_{MIN} = 10000 \cdot \frac{V_{REF}}{R_{IMIN}} = \frac{0.8V}{R_{IMIN}} \times 10^4 (A)$$

### TEMP (Pin 11)

TEMP is an Input for an external NTC thermistor. As shown in the Block Diagram, two comparators forms a window comparator with its low and high thresholds set by  $V_{TMIN}$  and  $V_{TMAX}$  respectively. When the voltage on the TEMP pin is outside the window, the charger stops. When the TEMP pin voltage falls back into the window, the charger starts a new charge cycle. The  $V_{TMIN}$  and  $V_{TMAX}$  voltage is determined by the internal resistor divider, as shown in the block diagram. See "Battery Pack Temperature Monitoring" for more information.

The TEMP pin is also used for battery removal detection. It is assumed that the thermistor is co-packed with the battery. When the charger sees a TEMP pin voltage that is 2.1V or higher, it assumes that the battery is removed. When a battery is removed, a FAULT signal is indicated and charging is halted. When a battery is inserted again, a new charge cycle starts.

### VBAT (Pin 12, 13, 14)

VBAT is the connection to a battery. Typically a 10 $\mu$ F Tantalum capacitor is needed for stability when no battery is attached to this pin. When a battery is connected, however, no capacitor is required for stability. A 0.1 $\mu$ F ceramic capacitor is recommended for decoupling.

## Description

### Initialization

The ISL6291 initializes as the input voltage rises above the power-on-reset (POR) threshold. Once the input voltage reaches the POR level, the V2P8 pin outputs a 2.8V voltage. This output voltage can be used as an adapter presence indication and to bias the thermistor circuit. The POR takes about 200 $\mu$ s. During the POR, the STATUS pin outputs a logic HIGH signal, and the FAULT pin outputs a logic LOW signal.

### Operation States

Immediately after the POR, the charger enters a charge state. A charge state always cycles through a trickle mode, a constant-current mode, and a constant voltage mode, as shown in Figure 1. If the battery completes a charge cycle without a fault, the operation moves to the inhibit state, waiting for the battery to be discharged to start another charge cycle. Two types of fault may occur during a charge cycle, namely, a TIMEOUT fault or a temperature fault (refer to Functional Pin Description on TIME, TOEN, and TEMP pins). If a fault occurs during the charge modes, the operation enters the fault state. The charger is in a standby state when the adapter is removed, or the EN pin of the IC is pulled to LOW. In the standby state, the charger IC draws less than 1 $\mu$ A current from the battery. The two open-drain pins, STATUS and FAULT, indicate the operation states of the charger (see Table 1).

TABLE 1. STATUS INDICATIONS

FAULT	STATUS	INDICATION
HIGH	HIGH	Charge completed with no fault (Inhibit) or Standby
HIGH	LOW	Charging in one of the three modes
LOW	HIGH	Fault

\*Both outputs are pulled up with external resistors.

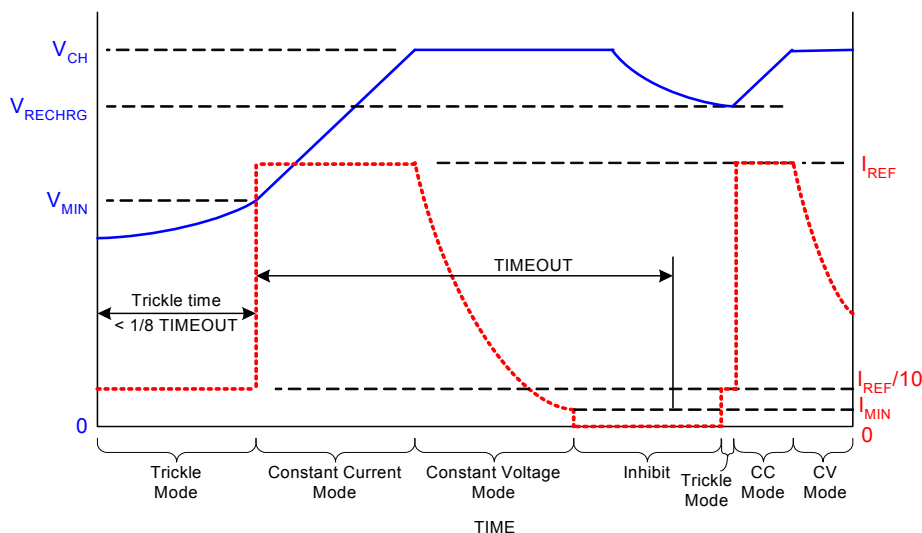

FIGURE 1. MODES OF OPERATION

The charger starts a new charge cycle when a wall adapter is plugged in, a new battery is inserted, a battery voltage drops below the re-charge threshold, a temperature fault ends, or the EN pin is toggled from LOW to HIGH.

### Trickle Charge Mode

A charge cycle always starts with the trickle charge mode. The trickle charge mode is to pre-condition the battery and prepare it for the fast charge (constant current or constant voltage charge). It is not recommended to fast charge a Li-ion battery when the battery is deeply discharged, indicated by a low battery voltage. When the ISL6291 sees a battery voltage lower than the  $V_{MIN}$  given in the Electrical Specifications, it forces 1/10 of the current in the constant current mode into the battery. The charger stays in the trickle mode until the battery voltage is above  $V_{MIN}$  for 15 consecutive oscillation cycles ( $T_{OSC}$ ). The 15-cycle delay is to avoid entering the constant current mode accidentally, caused by any transient voltage spike on the battery pack terminals. The charge time for the trickle mode is limited to 1/8 of the TIMEOUT interval (see TIME pin description and Figure 1). If the trickle charge time takes longer than 1/8 of the TIMEOUT interval, a TIMEOUT fault is issued and the charger is latched. The minimum trickle charge time is 15  $T_{OSC}$ , and the maximum time is 1/8 TIMEOUT. During the trickle mode, the STATUS pin is set to logic LOW, and the FAULT pin is set to logic HIGH.

### Constant Current Charge Mode

The battery is charged with a constant current programmed by the IREF pin resistor (see IREF pin description) during the constant current mode. The constant current is trimmed to 10% accuracy. The battery voltage rises towards the charge termination voltage  $V_{CH}$  in this mode. The constant current mode ends when the battery voltage reaches  $V_{CH}$ . The internal clock counter limits the maximum time for the constant current mode to the TIMEOUT interval. The counter is reset at the beginning of the this charge mode. If the

charge time exceeds the TIMEOUT interval, a fault is issued and the charger is latched. The charger then enters the Fault state.

The TIMEOUT limit is disabled when the TOEN pin is pulled to LOW (see TOEN pin description for more information). During the constant current charge mode, the STATUS pin remains LOW and the FAULT pin remains HIGH.

### Constant Voltage Charge Mode

The ISL6291 regulates the battery terminal voltage at  $V_{CH}$  in the constant voltage mode. As the battery continues being charged, the charge current starts to decrease, as shown in Figure 1. When the charge current drops to the minimum value  $I_{MIN}$ , programmed by the IMIN pin, the charge cycle completes. The total charge time for the constant current mode and the constant voltage mode must not exceed the TIMEOUT interval, unless the TOEN pin is pulled LOW; otherwise, the charger also stops charging and indicates a FAULT status. During the constant voltage mode, the STATUS remains LOW and the FAULT remains HIGH.

Two versions of ISL6291 (see Ordering Information) are available: a 4.1V termination voltage version, and a 4.2V termination voltage version.

### Inhibit State

The charger enters the Inhibit State once a normal charge cycle completes. The ISL6291 then monitors the battery voltage. Once the battery voltage falls below the  $V_{RECHRG}$  threshold, a new charge cycle starts, as shown in Figure 1. Both STATUS and FAULT are HIGH in this state.

### Fault State

Two types of fault may occur during a charge cycle: the TIMEOUT fault (refer to the TIME pin and the TOEN pin description), and the temperature fault (see TEMP pin description and the Battery Pack Temperature Monitoring section). When a TIMEOUT fault occurs, the charger is latched. The latch is released only by recycling the input power or toggling the EN signal. When a temperature fault occurs, the charger is reset and a new charge cycle starts when the temperature fault ends. In case of a fault, the FAULT pin indicates a logic LOW and the STATUS pin outputs a logic HIGH.

### Standby State

The charger is in the Standby State when the EN pin is held LOW or the wall adapter is removed. The charger draws less than  $1\mu\text{A}$  of standby current when the adapter is removed.

### Timing Diagram

Figure 2 summarizes the operation of the charger and the key signals after an adapter is attached to the charger input. No fault occurs in this diagram and the EN pin is assumed not connected to logic LOW.

### Internal Current Sensing

A 100,000:1 current mirror is employed to sense the current in the pass element, as shown in the Block Diagram. The current mirror is trimmed to 10% accuracy. The second mirrored output, represented by  $I_{SEN2}$  in the block diagram, is used to compare with the IMIN pin current to determine the end-of-charge condition.

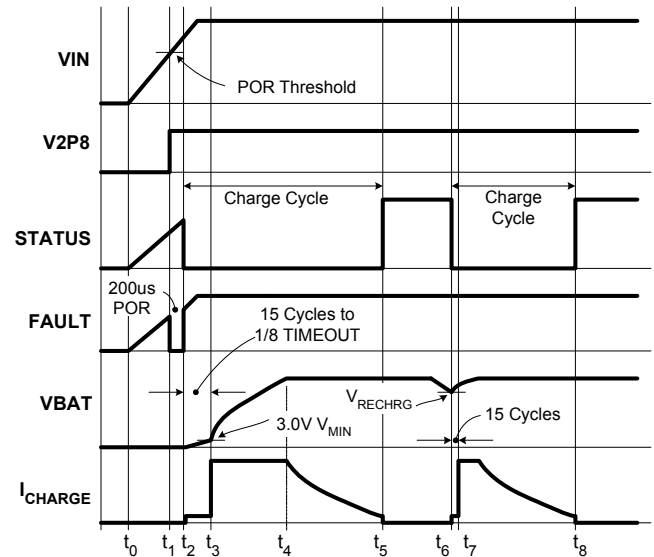

FIGURE 2. TIMING DIAGRAM AFTER AN ADAPTER IS ATTACHED TO THE CHARGER INPUT

### Charge Current Control

The charging current in the pass element is controlled by the current amplifier CA, as shown in the Block Diagram. The CA, the pass element, and the 100,000:1 current mirror form a control loop. During a trickle charge mode or a constant current charge mode, the control reference to the loop is the reference current  $I_R$ . The voltage amplifier VA does not affect the loop operation because the battery voltage is lower than the charge termination voltage  $V_{CH}$ , so that the voltage amplifier output is blocked by the diode connecting to the current reference. If the charge current in the PMOS pass element is too high, its mirrored output is higher than the reference  $I_R$ . The non-inverting input of the current amplifier has a higher voltage than the inverting input so that the current amplifier output increases, reducing the gate-to-source voltage of the PMOS pass element. The current in the pass element thereby reduces. If the charge current is too low, the current amplifier output reduces to force the current to increase.

During the Trickle mode charge, the current reference typically equals 1/10 of the current in the IREF pin. During the constant current mode, the reference current equals the current in the IREF pin.

If the temperature inside the IC rises above a typical value of  $100^\circ\text{C}$ , the current source block starts to reduce the reference current  $I_R$  at a rate of  $0.4\mu\text{A}/^\circ\text{C}$  for every degree of temperature rise.



**Charge Termination Voltage Regulation**

As the battery voltage rises to the 4.1V or 4.2V termination voltage, the voltage amplifier starts to output positive voltage and to source current. This current partially cancels the current of the reference current  $I_R$  to reduce the charge current. If the battery voltage increases further due to the charging, the voltage amplifier increases its output current to reduce the equivalent reference current. As a result, after the battery voltage reaches the termination voltage, the charge current starts to decrease.

As the charging current drops to the end-of-charge current level programmed by the IMIN pin, the charge stops. The large voltage control loop gain guarantees that the battery voltage is regulated within the 1% error specification.

**Internal Thermal Management**

The temperature rise of a linear charger is always a concern in real applications. The temperature rise is caused by the power dissipation of the charger. Maximum power dissipation occurs when the battery is charged in the constant current mode. The advanced thermal management function of the ISL6291 frees users from the temperature rise concern. The ISL6291 adopts a current-foldback technique against the temperature rise. Under normal operation, the ISL6291 charges the battery with the programmed  $I_{REF}$ . If the internal thermal monitoring circuit detects 100°C temperature in the IC, it starts to reduce the charge current to prevent further temperature rise. The gain for the current-foldback is 40mA/°C (or 0.4µA/°C for the reference current  $I_R$ ) after the internal temperature reaches 100°C; therefore, for a charger with the constant charge current set at 1A, the charge current is reduced to zero when the internal temperature rises to 125°C. The actual internal temperature should settle between 100°C to 125°C, depending on the operating conditions, if the temperature does rise above 100°C.

**Battery Pack Temperature Monitoring**

The ISL6291 uses two comparators to form a window comparator. Figure 3 shows the internal circuit. When the TEMP pin voltage is “out of the window,” as determined by the  $V_{TMIN}$  and  $V_{TMAX}$ , the charging is stopped. The two MOSFETs, Q1 and Q2, produce hysteresis for both upper and lower threshold. Figure 4 shows all the critical voltage levels and the output of the two comparators versus the TEMP pin voltage.

The external thermistor circuit is shown in Figure 3. The NTC thermistor  $R_T$  requires a pull-up resistor  $R_U$  to form a resistive divider.  $R_U$  should be pulled up to the 2.8V V2P8 pin. Assume the resistance of the NTC thermistor is  $R_{TH}$  at the high temperature limit, and is  $R_{TL}$  at the low limit. It can be shown that:

$$R_{TL} = 9 \cdot R_{TH}$$

Select an NTC thermistor whose resistance value satisfies the above equation. A curve-1 NTC thermistor from Vishay is a good candidate for this application. If a thermistor does not meet this requirement, using a resistor in parallel or series with the thermistor may solve the problem. Once the thermistor is selected, the pull-up resistor should be chosen as:

$$R_U = R_{TL}$$

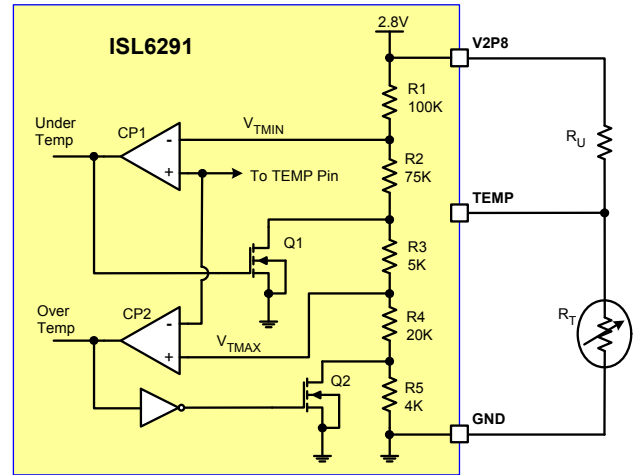

FIGURE 3. THE INTERNAL AND EXTERNAL CIRCUIT FOR THE BATTERY PACK TEMPERATURE MONITORING

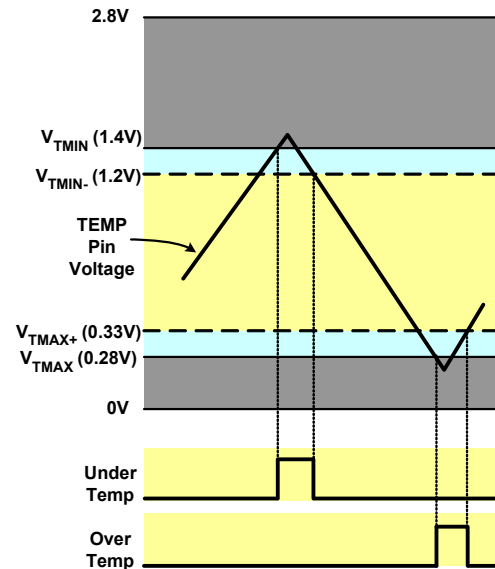

FIGURE 4. CRITICAL VOLTAGE LEVELS FOR TEMP PIN

If a parallel or series resistor is used, the  $R_{TL}$  value is the combined value at the low temperature limit. The temperature hysteresis can be calculated once the thermistor is selected. The typical hysteresis is about 3°C to 5°C.

## **Battery Removal Detection**

The ISL6291 assumes that the thermistor is co-packed with the battery and is removed together with the battery. When the ISL6291 sees a voltage of 2.1V or higher on the TEMP pin, it assumes that the battery is removed. When the battery is removed, the charger stops and indicates a fault signal. A new charge cycle starts when a battery is inserted again.

## **Output Capacitor $C_{OUT}$**

$C_{OUT}$  is typically a 10 $\mu$ F Tantalum capacitor if the charger is required to operate with no battery attached. For embedded battery applications, there is no requirement for a capacitor if the battery is placed close enough to the charger output. It is recommended, however, that the charger have at least a 0.1 $\mu$ F ceramic capacitor at the charger output for decoupling purposes.

## **Input Capacitor $C_{IN}$**

$C_{IN}$  is typically a 10 $\mu$ F Tantalum capacitor or 1 $\mu$ F Ceramic capacitor.

## **Stability**

The charger is stable with a wide range of external components, including the typical external components.

**Quad Flat No-Lead Plastic Package (QFN)  
Micro Lead Frame Plastic Package (MLFP)**

**L16.5x5B**

16 LEAD QUAD FLAT NO-LEAD PLASTIC PACKAGE  
(COMPLIANT TO JEDEC MO-220VHHB ISSUE C)

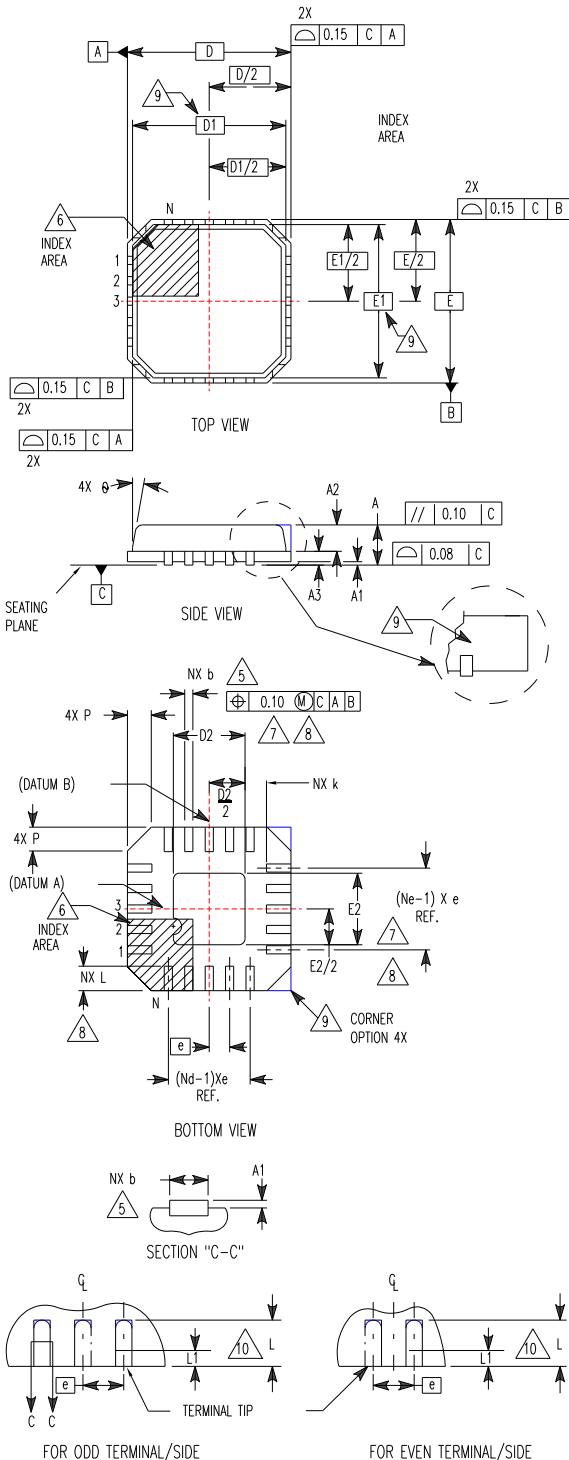

SYMBOL	MILLIMETERS			NOTES
	MIN	NOMINAL	MAX	
A	0.80	0.90	1.00	-
A1	-	-	0.05	-
A2	-	-	1.00	9
A3	0.20 REF			9
b	0.28	0.33	0.40	5, 8
D	5.00 BSC			-
D1	4.75 BSC			9
D2	2.95	3.10	3.25	7, 8
E	5.00 BSC			-
E1	4.75 BSC			9
E2	2.95	3.10	3.25	7, 8
e	0.80 BSC			-
k	0.25	-	-	-
L	0.35	0.60	0.75	8
L1	-	-	0.15	10
N	16			2
Nd	4			3
Ne	4			3
P	-	-	0.60	9
$\theta$	-	-	12	9

Rev. 1 10/02

**NOTES:**

1. Dimensioning and tolerancing conform to ASME Y14.5-1994.
2. N is the number of terminals.
3. Nd and Ne refer to the number of terminals on each D and E.
4. All dimensions are in millimeters. Angles are in degrees.
5. Dimension b applies to the metallized terminal and is measured between 0.15mm and 0.30mm from the terminal tip.
6. The configuration of the pin #1 identifier is optional, but must be located within the zone indicated. The pin #1 identifier may be either a mold or mark feature.
7. Dimensions D2 and E2 are for the exposed pads which provide improved electrical and thermal performance.
8. Nominal dimensions are provided to assist with PCB Land Pattern Design efforts, see Intersil Technical Brief TB389.
9. Features and dimensions A2, A3, D1, E1, P &  $\theta$  are present when Anvil singulation method is used and not present for saw singulation.
10. Depending on the method of lead termination at the edge of the package, a maximum 0.15mm pull back (L1) maybe present. L minus L1 to be equal to or greater than 0.3mm.

All Intersil U.S. products are manufactured, assembled and tested utilizing ISO9001 quality systems.  
Intersil Corporation's quality certifications can be viewed at [www.intersil.com/design/quality](http://www.intersil.com/design/quality)

*Intersil products are sold by description only. Intersil Corporation reserves the right to make changes in circuit design, software and/or specifications at any time without notice. Accordingly, the reader is cautioned to verify that data sheets are current before placing orders. Information furnished by Intersil is believed to be accurate and reliable. However, no responsibility is assumed by Intersil or its subsidiaries for its use; nor for any infringements of patents or other rights of third parties which may result from its use. No license is granted by implication or otherwise under any patent or patent rights of Intersil or its subsidiaries.*

For information regarding Intersil Corporation and its products, see [www.intersil.com](http://www.intersil.com)