

**NOT RECOMMENDED FOR NEW DESIGNS  
USE ISL9206  
PIN-FOR-PIN COMPATIBLE**

### FlexiHash™ For Battery Authentication

The ISL6296 is a highly cost-effective fixed-secret hash engine based on Intersil's FlexiHash™ technology. The device authentication is achieved through a challenge-response scheme customized for low-cost applications, where cloning via eavesdropping without knowledge of the device's secret code is not economically viable. When used for its intended applications, the ISL6296 offers the same level of effectiveness as other significantly more expensive high maintenance monetary-grade hash algorithm and authentication schemes.

The ISL6296 has a wide operating voltage range, and is suitable for direct powering from a 1-cell Li-Ion/Li-Poly or a 3-cell series NiMH battery pack. The ISL6296 can also be powered by the XSD bus when the bus pull-up voltage is 3.3V or higher. The device connects directly to the cell terminals of a battery pack, and includes on-chip voltage regulation circuit, POR, and a non-crystal based oscillator for bus timing reference.

Communication with the host is achieved through a single-wire XSD interface - (a light-weight subset of Intersil's ISD bus interface). The XSD bus is compatible for use with serial ports offered by all 8250 compatible UART's or a single GPIO (general purpose input and output) pin of a microprocessor.

A clone prevention solution utilizing the ISL6296 offers safety and revenue protection at the lowest cost and power, and is suitable for protection against after-market replacement for a wide variety of low-cost applications.

### Pinouts

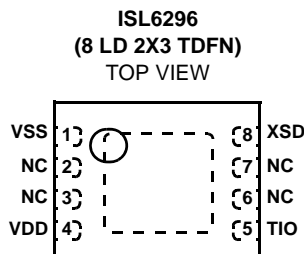
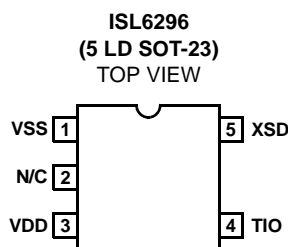

### Features

- Challenge-response based authentication scheme using 32-Bit challenge code and 8-Bit authentication code.
- Fast and flexible authentication process. Multi-pass authentication can be used to achieve the highest security level if necessary.
- 16x8 OTP ROM stores up to three sets of 32-Bit host-selectable secrets with additional programmable memory for storage of up to 48 bits of ID code and/or pack information.
- FlexiHash engine uses two sets of 32-Bit secrets for authentication code generation.
- Non-unique mapping of the secret key to an 8-Bit authentication code maximizes hacking difficulty due to need for exhaustive key search (superior to SHA-1).
- Supports 1-cell Li-ion/Li-Poly and 3-cell series NiMH battery packs (2.6V ~ 4.8V operation), or powered by the XSD bus.
- XSD single-wire host bus interface communicates with all 8250-compatible UART's or a single GPIO. Supports CRC on read data and transfer bit-rate up to 23kbps.
- True "Zero Power" Sleep mode - (automatically entered after a bus inactivity time-out period)
- 5 Ld SOT-23 and 8 Ld TDFN (2mmx3mm) packages
- -25°C to +85°C operating temperature range
- Pb-free available (RoHS compliant)

### Applications

- Battery Pack Authentication
- Printer Cartridges
- Add-on Accessories
- Other Non-Monetary Authentication Applications

### Related Literature

- Application Note AN1165 "ISL6296 Evaluation Kit"
- Application Note AN1166 "FlexiHash™ Engine Algorithm"
- Application Note AN1167 "Implementing XSD Host Using a GPIO"
- Technical Brief TB363 "Guidelines for Handling and Processing Moisture Sensitive Surface Mount Devices (SMDs)"

**Ordering Information**

<b>PART NUMBER (Note 1)</b>	<b>PART MARKING</b>	<b>TEMP. RANGE (°C)</b>	<b>PACKAGE Tape and Reel</b>	<b>PKG. DWG. #</b>
ISL6296DHZ-T	296Z	-25 to +85	5 Ld SOT-23 Tape and Reel (Pb-free)	P5.064
ISL6296DRZ-T	96Z	-25 to +85	8 Ld 2x3 TDFN Tape and Reel (Pb-free)	L8.2x3A
ISL6296DH-T	296D	-25 to +85	5 Ld SOT-23 Tape and Reel	P5.064
ISL6296EVAL1	ISL6296 Evaluation Kit			

\* Please refer to TB347 for details on reel specifications.

**NOTES:**

1. These Intersil Pb-free plastic packaged products employ special Pb-free material sets; molding compounds/die attach materials and 100% matte tin plate PLUS ANNEAL - e3 termination finish, which is RoHS compliant and compatible with both SnPb and Pb-free soldering operations. Intersil Pb-free products are MSL classified at Pb-free peak reflow temperatures that meet or exceed the Pb-free requirements of IPC/JEDEC J STD-020.

**Absolute Maximum Ratings (Reference to GND)**

Supply Voltage (VDD) .....	5.5V
All Other Pins .....	-0.5 to VDD+0.5V
ESD Rating	
Human Body Model (Per MIL-STD-883 Method 3015.7) .....	4000V
Machine Model (Per EIAJ ED-4701 Method C-111) .....	400V
CDM .....	1000V

**Recommended Operating Conditions**

Ambient Temperature Range .....	-25°C to +85°C
---------------------------------	----------------

**Thermal Information**

Thermal Resistance (Typical)	$\theta_{JA}$ (°C/W)	$\theta_{JC}$ (°C/W)
SOT-23 Package (Note 2) .....	200	N/A
2x3 TDFN Package (Notes 3, 4) .....	70	10.5
Maximum Junction Temperature (Plastic Package) .....	+125°C	
Maximum Storage Temperature Range .....	-40°C to +125°C	
Pb-free reflow profile .....	see link below	
	<a href="http://www.intersil.com/pbfree/Pb-FreeReflow.asp">http://www.intersil.com/pbfree/Pb-FreeReflow.asp</a>	

CAUTION: Do not operate at or near the maximum ratings listed for extended periods of time. Exposure to such conditions may adversely impact product reliability and result in failures not covered by warranty.

NOTES:

- $\theta_{JA}$  is measured with the component mounted on a high effective thermal conductivity test board in free air. See Tech Brief TB379 for details.
- $\theta_{JA}$  is measured in free air with the component mounted on a high effective thermal conductivity test board with "direct attach" features. See Tech Brief TB379.
- For  $\theta_{JC}$ , the "case temp" location is the center of the exposed metal pad on the package underside.
- Parts are 100% tested at +25°C. Temperature limits established by characterization and are not production tested.

**Electrical Specifications** Unless otherwise noted, all parameters are guaranteed over the operational supply voltage and temperature range of the device as follows:  $T_A = -25^\circ\text{C}$  to  $+85^\circ\text{C}$ ;  $V_{DD} = 2.6\text{V}$  to  $4.8\text{V}$ .

PARAMETER	SYMBOL	TEST CONDITIONS	MIN (Note 5)	TYP	MAX (Note 5)	UNITS
<b>DC CHARACTERISTICS</b>						
Supply Voltage	$V_{DD}$	During normal operation	2.6	-	4.8	V
		During OTP ROM programming	2.8	-	4.8	V
Run Mode Supply Current (exclude I/O current)	$I_{DD}$	$V_{DD} = 4.2\text{V}$	-	110	140	$\mu\text{A}$
		$V_{DD} = 4.8\text{V}$	-	120	160	$\mu\text{A}$
Sleep Mode Supply Current	$I_{DDS}$	$V_{DD} = 4.2\text{V}$ , XSD pin floating	-	0.15	0.5	$\mu\text{A}$
OTP Programming Mode Supply Current	$I_{DDP}$	For ~ 1.8ms duration per write operation	-	250	500	$\mu\text{A}$
Internal Regulated Supply Voltage	$V_{RG}$	Observable only in test mode	2.3	2.5	2.7	V
Internal OTP ROM Programming Voltage	$V_{PP}$	Observable only in test mode	11	12	13	V
POR Release Threshold	$V_{POR+}$		1.9	2.2	2.4	V
POR Assertion Threshold	$V_{POR-}$		1.5	1.8	2.1	V
<b>XSD PIN CHARACTERISTICS</b>						
XSD Input Low Voltage	$V_{IL}$		-0.4	-	0.5	V
XSD Input High Voltage	$V_{IH}$		1.5	-	$V_{DD+0.4\text{V}}$	V
XSD Input Hysteresis	$V_{HYS}$		-	400	-	mV
XSD Internal Pull-Down Current	$I_{PD}$	$V_{DD} = 2.6\text{V}$	-	0.8	-	$\mu\text{A}$
		$V_{DD} = 4.2\text{V}$	-	1.2	2.0	$\mu\text{A}$
		$V_{DD} = 4.8\text{V}$	-	1.8	2.5	$\mu\text{A}$
XSD Output Low Voltage	$V_{OL}$	$I_{OL} = 1\text{mA}$	-	-	0.4	V
XSD Input Transition Time	$t_X$	10% to 90% transition time	-	-	2	$\mu\text{s}$
XSD Output Fall Time	$t_F$	90% to 10%, $C_{LOAD} = 12\text{pF}$	-	-	50	ns
XSD Pin Capacitance	$C_{PIN}$		-	6	-	pF
<b>XSD BUS TIMING CHARACTERISTICS (Refer to XSD Bus Symbol Timing Definitions Tables)</b>						
Programming Bit Rate		$x = 0.5$ to $4$	2.89	-	23.12	kHz

## ISL6296

**Electrical Specifications** Unless otherwise noted, all parameters are guaranteed over the operational supply voltage and temperature range of the device as follows:  $T_A = -25^{\circ}\text{C}$  to  $+85^{\circ}\text{C}$ ;  $V_{DD} = 2.6\text{V}$  to  $4.8\text{V}$ . **(Continued)**

PARAMETER	SYMBOL	TEST CONDITIONS	MIN (Note 5)	TYP	MAX (Note 5)	UNITS
XSD Input Deglitch Time	$T_{WDG}$	Pulse width narrower than the deglitch time will not cause the device to wake up	7	-	20	$\mu\text{s}$
Device Wake-Up Time	$T_{WKE}$	From falling-edge of break command issued by host to falling-edge of break command returned by device	35	60	100	$\mu\text{s}$
Device Sleep Wait Time	$T_{SLP}$	From when the '11' Opcode is detected to the shut-off of the internal regulator	4	-	-	$\mu\text{s}$
Auto-Sleep Time-Out Period	$T_{ASLP}$	From the last transition detected on the XSD bus to the device going into sleep mode	0.9	-	1.1	s
OTP ROM Write Time	$T_{EEW}$	From the last BT of the 2nd write data frame to when device is ready to accept the next instruction	-	1.8	1.9	ms
Hash Calculation Time	$T_{HASH}$	From the last BT of the Challenge Code Word from the host to the Authentication Code being available for read	-	1	-	BT
Soft-Reset Time	$T_{SRST}$	From the last BT of the Soft-Reset instruction issued by the host to the falling-edge of break command returned by device	-	-	30	$\mu\text{s}$
<b>AC CHARACTERISTICS</b>						
Oscillator Clock Frequency	$f_{OSC}$	Internal bus reference clock	505	532	560	kHz
Charge Pump Clock Frequency	$f_{CP}$	Internal high speed clock (observable only in test mode)				
		Low-speed mode	3.6	5	6	MHz
		High-speed mode	16	20	24	MHz

### Pin Descriptions

PIN NUMBER	PIN NAME	DESCRIPTION
1	VSS	System ground.
2	NC	No connection.
3	VDD	Supply voltage.
4	TIO	Production test I/O pin. Used only during production testing. Must be left floating during normal operation.
5	XSD	Communication bus with weak internal pull-down to VSS. This pin is a Schmitt-trigger input and an open-drain output. An appropriate pull-up resistor is required on the host side.

Typical Applications

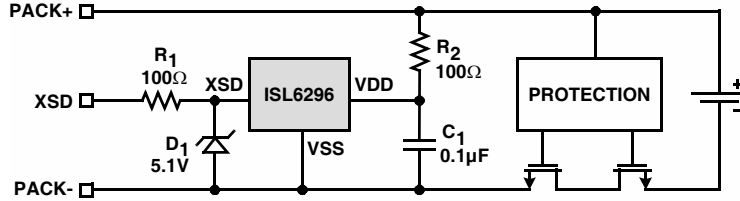

FIGURE 1. TYPICAL APPLICATION WITH THE ISL6296 POWERED BY THE BATTERY

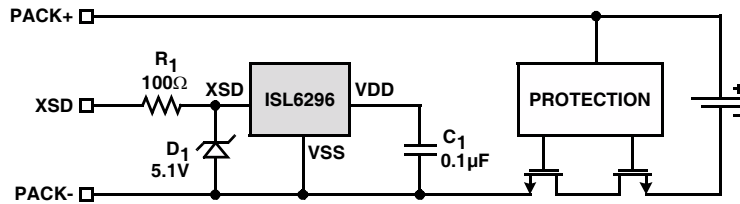

FIGURE 2. TYPICAL APPLICATION WITH THE ISL6296 POWERED BY THE XSD BUS

Block Diagram

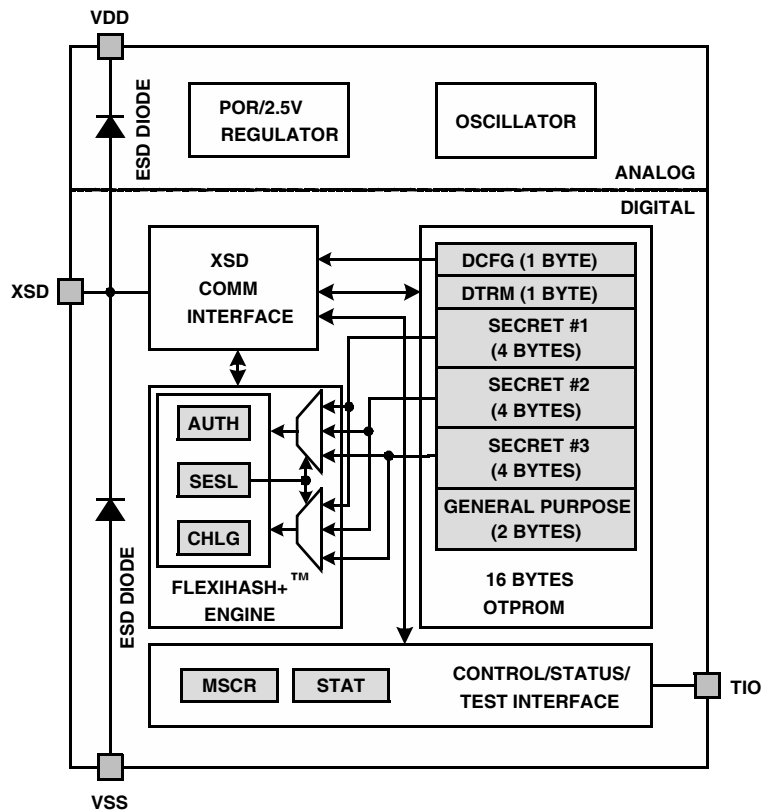

FIGURE 3. FUNCTIONAL BLOCK DIAGRAM

## Theory of Operation

The ISL6296 contains all circuitry required to support battery pack authentication based on a challenge-response scheme. It provides a 16-Byte One-Time Programmable Read-Only Memory (OTPROM) space for the storage of up to 96-Bit of secret for the authentication and other user information. A 32-Bit CRC-based hash engine (FlexiHash™) calculates the authentication result immediately after receiving a 32-Bit random challenge code. The communication between the ISL6296 and the host is implemented through the XSD single-wire communication bus.

Major functions within the ISL6296 include the following: (as shown in Figure 3).

- Power-on reset (POR) and a 2.5V regulator to power all internal logic circuits.
- 16x8-Bit (16-Byte) OTP ROM as shown in Table 8. The first part (two bytes) contains the device default configuration (DCFG) information (such as the device address and the XSD communication speed) and the default trimming (DTRM) information (such as the internal oscillator frequency trimming). The second part contains two groups (12-Byte) of memory that can be independently locked out for the storage of up to three sets of secret. The last part provides two additional bytes of space for general-purpose information.
- Control functions, including master control (MSCR) and status (STAT) registers (as shown in Table 9), interrupt generation, and the test-related interface.
- FlexiHash™ engine that includes the 32-Bit CRC-based hash engine, secret selection register, challenge code register, and the authentication result register. Table 10 shows all the registers.
- XSD communication bus Interface. The XSD device address and the communication speed are configured in the DCFG address in the OTPROM, as given in Table 8.
- Time Base Reference.

The following explain in detail the operation of the ISL6296.

### Power-On Reset (POR)

The ISL6296 powers up in Sleep mode. It remains in Sleep mode until a power-on 'break' command is received from the host through the XSD bus. The initial power-on 'break' can be of any pulse width as long as it is wider than the XSD input deglitch time (20µs). Once the 'break' command is received, the internal regulator is powered up. About 20µs after the falling edge of the power-on 'break', an internal POR circuit releases the reset to the digital block, and a POR sequence is started. During the POR sequence, the ISL6296 initializes itself by loading the default device configuration information from pre-assigned locations within the OTP ROM memory. After initialization, a 'break' command is returned to the host to indicate that the ISL6296 is ready and waiting for a bus transaction from the host.

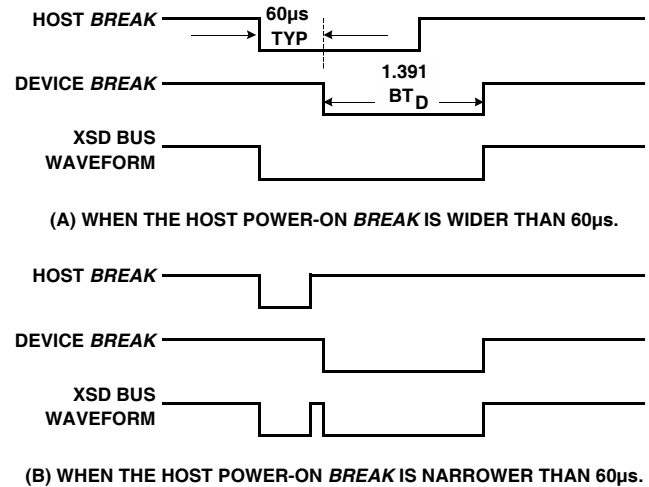

**FIGURE 3. POWER-ON BREAK SIGNAL TO WAKE-UP THE ISL6296 FROM SLEEP MODE**

Note that the ISL6296 will initiate the power-on sequence without waiting for the power-on 'break' signal to return to the high state. If the host sends an initial 'break' pulse wider than 60µs, the device-ready 'break' returned by the ISL6296 will likely be merged with the pulse sent by the host and, therefore, may not be detectable. Figure 3 illustrates the waveforms during the Power-on Reset. Figure 3 (A) represents the case when the power-on 'break' rising edge occurs after the device starts sending the 'break'. Figure 3 (B) represents the case when the power-on 'break' finishes before the device sends its 'break'. The device break signal is always 1.391 x of the device bit-time (BT, see XSD Bus Interface section for more details). Either case in Figure 3 will wake up the device successfully if the device is in the sleep mode.

**NOTE:** It is important to keep in mind that a narrow 'break' signal will be taken as a normal bit signal and cause errors, if the device is not in the sleep mode. For this reason, the narrow power-on 'break' signal should be used only if the user has to see the returned 'break' signal.

### Auto-Sleep

While the ISL6296 is powered up and there is no bus activity for more than about 1S, the device will automatically return to Sleep mode. Sleep mode can be entered independent of whether the XSD bus is held high or low. While the ISL6296 is in Sleep mode, it is recommended that the XSD bus be held low to eliminate current drain through the XSD-pin internal pull-down current.

Auto-Sleep mode can be disabled by clearing the ASLP bit in the MSCR register. By default, Auto-Sleep is always enabled at power-up and after a soft reset. Auto-sleep function can be permanently disabled by clearing the 0-00[2] bit (the ASLP bit in DCFG) during OTP ROM programming.

## OTP ROM

The 16-Byte OTP ROM memory is based on EEPROM technology and is incorporated into the ISL6296 for storage of non-volatile information. OTP ROM contents (refer to Table 8) can include but not limited to:

- 1) Device default settings (address 0-00)
- 2) Factory programmed trim parameters (address 0-01)
- 3) Device authentication secrets (address 0-02 to 0-0D)
- 4) Pack information and ID (address 0-0E and 0-0F)

The memory can be written multiple times before two lock-out bits (SLO[1:0] in DCFG, see Table 8) being set. The SLO[1] (bit 1) locks out the memory between 0-02 and 0-09 and the SLO[0] (bit 0) locks out the memory between 0-0A to 0-0D. These two bits can be set independently. Prior to lock-out, the memory can be written and read directly through the XSD bus interface. After lock-out, writing to all ROM addresses and reading from secret code locations will be permanently disabled after performing a reset cycle.

Writing to the EEPROM requires the supply voltage at the VDD pin be maintained at a minimum of 2.8V. Failure to do so may result in unreliable ROM programming or total write failure.

The OTP ROM must be written two bytes at a time, but 2, 4 or 16-Bytes of data can be read by the host in a single bus transaction. Only even addresses are allowed in OTP ROM read/write. A 16-Byte read with CRC allows the entire ROM content to be quickly verified by simply checking the CRC byte. The DTRM address stores the default trimming parameters and is a read-only address. The DCFG and DTRM (0-00 and 0-01 addresses) need be written simultaneously but the data to the DTRM address is ignored.

The OTP ROM writing process takes approximately 1.8ms per two-Byte. While the write process is taking place, no bus transaction is allowed. Attempt to access the ISL6296 during an on-going write process will result in the device ignoring the access instruction and issuing an interrupt to the host. The OTP ROM programming is register-based, and may be performed at the pack manufacturer's facility.

## Device Control and Status

The ISL6296 has a control and a status register. The control register can be read and written by the host but the status register is read only. Both registers contain the device configuration information (see Table 9). The status register also contains the device status information that may lead to an interrupt signal to the host.

Following a host-initiated power-on 'break' signal or soft reset command, the ISL6296 will configure its default mode of operation based on information stored within DCFG address of the OTP ROM. The default configuration is loaded into the master control (MSCR) and the status

(STAT) registers. Functions that are configured by OTP ROM settings include:

- a) device address (DAB[1:0])
- b) XSD bus speed (SPD[1:0])
- c) register default settings (eINT and ASLP)
- d) ROM read/write lock-out (SLO[1:0])

The ISL6296 incorporates interrupt functions to allow the host to be quickly informed of device status and error conditions. Available interrupts are summarized in Table 1.

When an interrupt enable bit is set, a 'break' command is sent to the host whenever its corresponding interrupt status bit is set. After this, the host should read the STAT register immediately. If the following instruction frame from the host does not access the STAT register, another 'break' will be sent immediately after receiving the full instruction frame. This process is repeated until the host reads from the STAT register. Upon reading of the STAT register, all status bits will be cleared.

Refer to the MSCR and STAT register descriptions for detailed explanation of the interrupt functions.

## FlexiHash™ Engine

The FlexiHash™ engine contains a 32-Bit CRC-based hash engine and three registers. Table 10 lists the three registers. The 1-Byte secret selection (SESL) register select two sets of secret (32-Bit each) from the OTP ROM to program the hash engine. The 4-Byte challenge code register (CHLG) receives the challenge code from the host through the XSD bus. Once the challenge code is received, the hash engine generates a 1-Byte authentication result code and stores in the AUTH register for the host to read. Figure 4 shows the data flow of the authentication process. The following sections describe the authentication process and FlexiHash™ encoding scheme in detail.

## THE DEVICE AUTHENTICATION PROCESS

To start an authentication process, the host sends a 'break' command to wake up the ISL6296. Then host writes to the SESL register to select the two sets of secrets to be used for authentication code generation. After that, the host generates a pseudo-random 4-byte challenge code to input into the CHLG register to initiate the authentication process. Upon receiving the fourth byte of the challenge code, the ISL6296 immediately starts computing the authentication code. Once the computation is completed, the 8-bit authentication code is made available at the AUTH register for the host to read out. The host reads this code and, concurrently, calculates the correct authentication code based on the challenge code it generated and the same secrets chosen, and finally compares the result with the authentication code read from the device. If the codes do not match up, the device is a fake device and the host may shut itself down. The flow chart in Figure 5 summarizes the previous process that the host needs to execute.

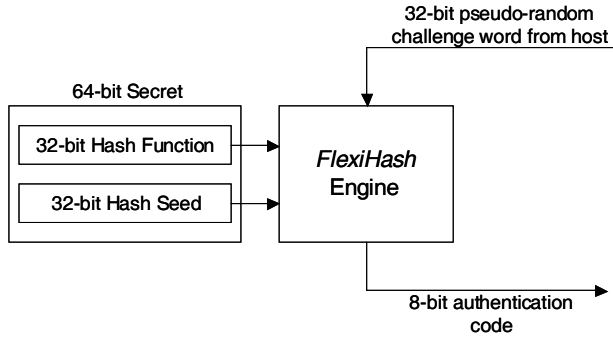

FIGURE 4. AUTHENTICATION PROCESS FLOW DIAGRAM

It is recommended that device authentication be done once in a while to maximize its effectiveness. Before a new challenge code can be accepted by the device, the SESL register must be re-written again to ensure that the original seeds are re-loaded from the OTP ROM into the hash engine prior to performing the next authentication code calculation. Failure to follow the sequence will result in a bus error, causing the sBER flag to be set in the STAT register.

#### SET-UP FOR DEVICE AUTHENTICATION SUPPORT

To configure the host and the ISL6296 to support device authentication function, the pack manufacturer will need to select at least 2 sets of 32-bit secret codes. For greater security, a third set of 32-bit secret may be used. The FlexiHash™ engine requires two sets of 32-bit secrets for use in its hash calculation: the first set to define its hash function, and the second set to initialize its seed for hash calculation. These two sets can be selected from the same secret location. The chosen secret codes are to be kept by the pack manufacturer and maintained at utmost confidentiality.

After the secrets have been determined, they are written into the device's OTP ROM. After verification that the codes have been written in correctly, the relevant secrets lock-out bits at ROM address location 0-00 should be set. Once set, the lock-out bits can no longer be cleared. Thereafter, read/write access to the secret information will no longer be possible, and the secret codes are made available only to the FlexiHash™ engine for generation of authentication code based on a challenge code input from the host.

On the host side, the same secret codes will need to be kept, and the same FlexiHash™ engine will have to be implemented in firmware. Refer to the application note AN1166 for detailed information of firmware implementation. It is important that the secret codes be stored scrambled in the host's non-volatile memory so that the secret information cannot be easily revealed by monitoring signal transfer on the host PCB.

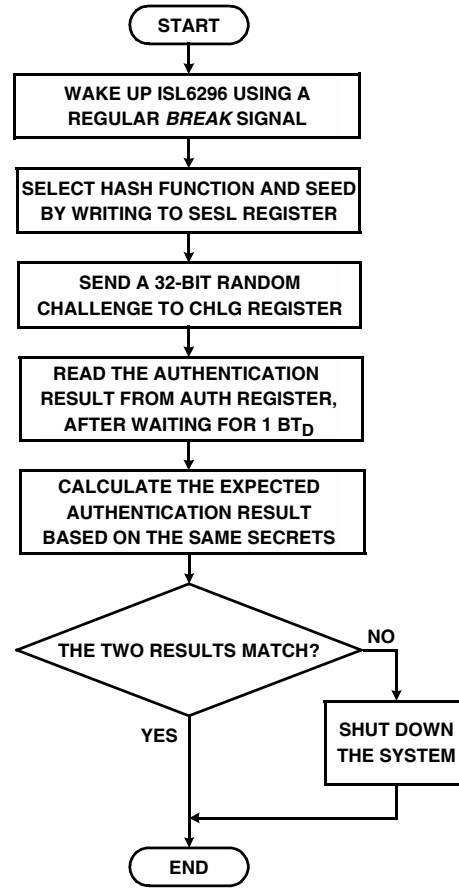
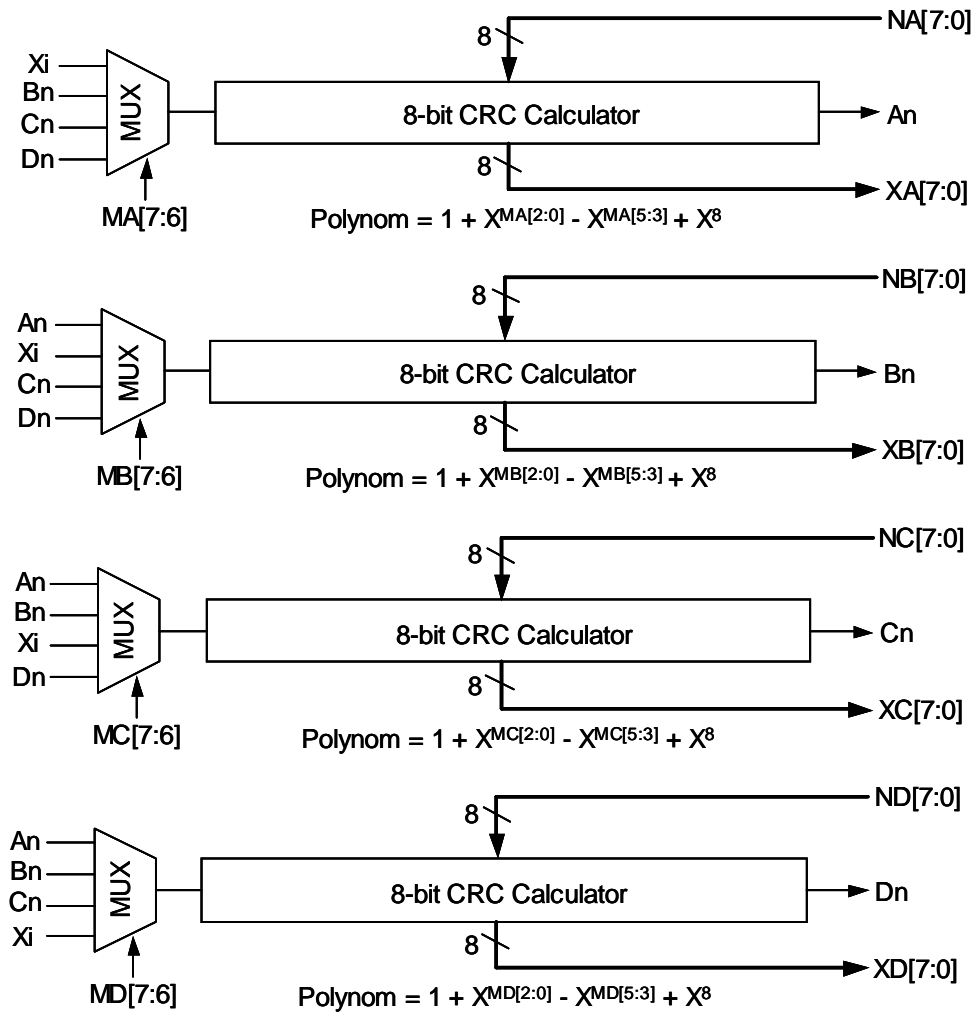

FIGURE 5. FLOW CHART FOR AUTHENTICATION PROCESS

#### THE HASH ENGINE

The hash engine consists of 4 separate programmable 8-bit CRC calculators. Two sets of 32-bit secret codes are used by the hash engine for authentication code generation. The first set is used to define the CRC polynomial as well as the input selection for each of the CRC calculators. The second is used as initial seeds for the CRC calculations. Outputs of the 4 CRC calculators are logically combined to produce the 8-bit output of the overall FlexiHash™ engine. Block diagram of the FlexiHash engine is illustrated in Figure 6. More detailed description of the hash engine can be found in the application note AN1166.





$$Y[7:0] = XA[7:0] \oplus S2R\{XB[7:0]\} \oplus S4R\{XC[7:0]\} \oplus S6R\{XD[7:0]\}$$

Legend:

- Xi 32-bit Challenge Code Word serial bit-stream
- An,Bn,Cn,Dn CRC calculator serial outputs
- XA,XB,XC,XD CRC calculator 8-bit parallel outputs
- MA,MB,MC,MD CRC polynomial and input selection codes
- NA,NB,NC,ND CRC register initialization seeds
- SnR{ } n-bit cyclical right shift function
- Y[7:0] 8-bit Authentication Code output

FIGURE 6. BLOCK DIAGRAM OF THE FLEXIHASH ENGINE

### XSD Host Bus Interface

Communication with the host is achieved through XSD, a light-weight subset of Intersil's ISD single-wire bus interface. XSD is a programmable-rate pseudo-synchronous bidirectional host-initiated instruction-based serial communication interface that allows up to two slave devices to be attached and addressed separately. It includes features to enable quick and reliable communication. The communication protocol is optimized for efficient transfer of data between the device and the host. The list below outlines the features supported by the XSD bus interface:

- Programmable bit rate up to 23kbps
- Up to 2 devices can be connected to the host and addressed separately
- 16-Bit host instruction frame supports multi-Byte register read and write
- Built-in communication error detection
- CRC generation capability
- Supports interrupt signaling
- Integrated bus inactivity detector for automatic activation of sleep mode

### XSD BUS PHYSICAL MODEL

The physical model of the XSD bus is shown in Figure 7. The model shows a single-wire connection between the host and the device, not including the ground signal. The input logic on the device side is designed to be compatible with any voltage between 1.8V to 5.0V. The host interface should contain an open-drain or open-collector output. The pull-up resistor  $R_{PU}$  can be connected either to the host supply voltage  $V_{DDH}$  or the device supply voltage  $V_{DDD}$ . Typically the host supply voltage should be used for pull-up.

### DATA TRANSFER PROTOCOL

To initiate a transaction, the host first sends a 16-bit instruction frame to the device, followed by data byte frame(s) if the instruction is a write operation. The instruction frame consists of a chip-select code, operation code, register bank and address pointer, and number of data bytes information, as shown in Figure 9. If the instruction is a read operation, the device will return 1 to 17 byte frames of data

back to the host. The serial data transfer always takes place with the LSB first. The following explains the bus symbols and the transaction frames are introduced in later sections.

### BUS SIGNALING SYMBOLS

The XSD bus is nominally held high. Various bus symbols and commands are generated by active-low pulse width modulation. Following are the set of valid bus signaling symbols supported by the XSD interface:

#### 1) break (issued by host):

- used to wake the device up from Sleep mode (Note: a narrow 'break' can also be used to wake up the device from the Sleep mode, as described in the Power-on Reset "Power-On Reset (POR)" on page 6.
- used to reset the device's XSD bit counters and time qualifiers
- used to signal a change in communication channel (from one slave device to another)

#### 2) break (issued by device):

- used as 'device-ready' indication to the host (after a Soft-reset or wake up from Sleep mode)
- used as an interrupt indicator

#### 3) '1' symbol:

- used for instruction and data coding

#### 4) '0' symbol:

- used for instruction and data coding

### SYMBOL TIMING DEFINITIONS

Symbol timings are defined in terms of bit-time (BT), determined by the selected bus transfer bit-rate pre-programmed into the device's OTP ROM location 0-00[5:4]. Selectable bus speeds are: 2.89kHz ( $x = 0.5$ ), 5.78kHz ( $x = 1$ ), 11.56kHz ( $x = 2$ ) and 23.12kHz ( $x = 4$ ).

An instruction or data frame consists of a sequence of '1' and/or '0' symbols. Figure 8 illustrates the timing definitions. A '1' symbol is nominally 0.3 BT wide while a '0' symbol is nominally 0.7 BT wide. One '1' or '0' symbol is represented in each BT period. Any detected pulse width less than 0.124 BT wide will be interpreted as a glitch and will result in a bus error. Tables 2 and 3 summarize the timing definitions of all

TABLE 1. INTERRUPT EVENT SUMMARY

CONDITION	INTERRUPT ENABLE BIT	INTERRUPT STATUS FLAG	INTERRUPT EVENT
OTP ROM Write-in-Progress	eEEW (fixed)	sEEW	Accessing the ISL6296 during an on-going ROM write process (used only during initial OTP ROM programming).
XSD Bus Error	eINT	sBER	XSD bus error or invalid instruction frame detected. Improper authentication sequence detected.
Register Access Error	eINT	sACC	Accessing protected registers.

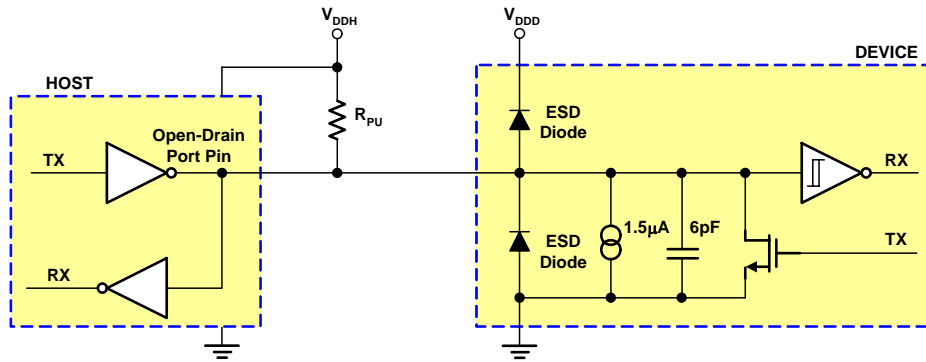

FIGURE 7. THE CIRCUIT MODEL FOR THE XSD SERIAL BUS

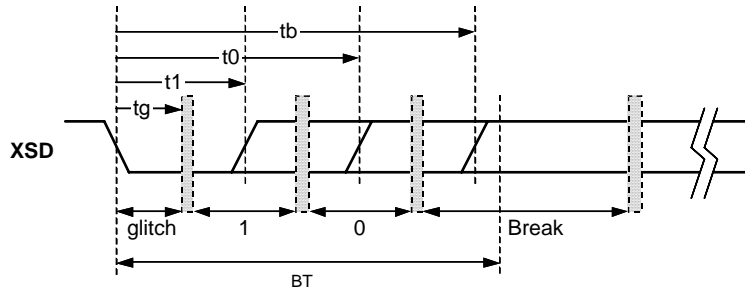

FIGURE 8. THE BUS SIGNAL TIMING DIAGRAM

TABLE 2. HOST TIMING DEFINITIONS OF SYMBOLS AND BUS SIGNALING

PARAMETER	SYM	DESCRIPTION	MIN	TYP	MAX	UNIT
Bit Time	BT <sub>H</sub>	x = 0.5, 1, 2, or 4		173.6/x		µs
Deglitch period	tg	PW (Pulse Width) less than this will result in a frame error			0.124	BT <sub>H</sub>
'1' pulse width	t1 <sub>H</sub>	PW in this range will be interpreted as a '1' code	0.227		0.453	BT <sub>H</sub>
'0' pulse width	t0 <sub>H</sub>	PW in this range will be interpreted as a '0' code	0.591		0.824	BT <sub>H</sub>
'break' time	tb <sub>H</sub>	PW in this range will be interpreted as a 'break' command	1		100	BT <sub>H</sub>

NOTE: Unless otherwise stated, all pulse width (PW) referenced are with respect to an active-low pulse.

TABLE 3. DEVICE TIMING DEFINITIONS OF SYMBOLS AND BUS SIGNALING

PARAMETER	SYM	DESCRIPTION	MIN	TYP	MAX	UNIT
Bit Time	BT <sub>D</sub>	x = 0.5, 1, 2, or 4	164.2/x	172.8/x	181.4/x	µs
'1' pulse width	t1 <sub>D</sub>	'1' code transmit pulse width		0.304		BT <sub>D</sub>
'0' pulse width	t0 <sub>D</sub>	'0' code transmit pulse width		0.696		BT <sub>D</sub>
'break' time	tb <sub>D</sub>	PW in this range will be interpreted as a 'break' command		1.391		BT <sub>D</sub>

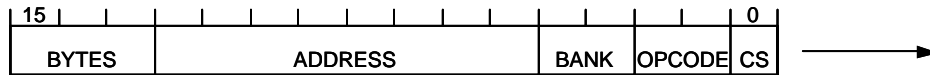

FIGURE 9. THE 16-BIT INSTRUCTION FRAME FIELD DEFINITION

TABLE 4. DEFINITION OF THE OPCODE FIELD

OPCODE	DESCRIPTION	ACTION
00	Write Operation	Write to device register
01	Read Operation (normal)	Read from device register
10	Read Operation (with CRC)	Read from device register. Append 1-Byte CRC to the end of the last read frame.
11	Sleep Mode Activation	Immediately sets the device in Sleep mode. <b>Note: After detecting the '11' Opcode, the device immediately enters sleep mode. If more than 3 bits sent, subsequent pulses may wake the device up again.</b>

### Access Instruction Frame

The XSD access instruction frame is shown in Figure 9. The instruction frame consists of 16 bits of digital signal with the contents described as follows.

#### CS FIELD

The CS field is a 1-Bit Chip Address Selection. An initial 1-bit Chip Address code of '0' is pre-programmed into the device's OTP ROM address location 0-00[7:6] at the time of chip manufacture, and may be re-programmed by the pack manufacturer if needed. If the CS code in the instruction does not match the device's Chip Address code, the instruction, and any subsequent frames that follow, will be ignored until a break command is received.

#### OPCODE FIELD

The OPCODE is a 2-bit field defines the operation of the transaction following the instruction frame. The operations are described in Table 4.

#### BANK FIELD

The memories in the ISL6296 are divided into four banks. The BANK field is defined in Table 5.

TABLE 5. BANK FIELD DEFINITION.

BANK	MEMORY/REGISTER BANK SELECTION
00	OTP ROM
01	Control and Status Registers
10	Device Authentication Registers
11	Test Registers (Reserved)

#### ADDRESS FIELD

The address field indicates the starting address of a memory or register read or write sequence. Keep in mind that only odd starting addresses are allowed for the OTP ROM access.

#### BYTES FIELD

The bytes field indicates the number of data bytes to read or write, not including the CRC byte. Not all BYTES Field settings are supported. Only settings marked with an 'X' is valid for a particular bus instruction, as indicated in Table 6. Attempt to read or write with an invalid BYTES setting may yield unpredictable results.

Writing to OTP ROM can occur at only two bytes at a time, but reading from OTP ROM can happen at 2, 4 or 16 bytes at a time. Writing to and reading from OTP ROM in any other byte denomination will yield unpredictable result, and should therefore be strictly prohibited.

TABLE 6. DEFINITION OF THE BYTES FIELD

BYTES FIELD	DATA BYTES TO FOLLOW	OTP ROM WRITE	OTP ROM READ	REG READ OR WRITE	CHLG CODE WRITE	COMMENTS
0	0					Invalid selection. Causes a bus error.
1	1			X		Must use 1-byte read for clearing of the STAT register.
2	2	X	X	X		
3	N/A					Invalid selection. Causes a bus error.
4	4		X		X	
5 to 6	N/A					Invalid selection. Causes a bus error.
7	16		X			For reading from OTP ROM only (prior to lock-out).

**Bus Transaction Protocol**

The XSD bus for the ISL6296 defines three types of bus transactions. Figure 10 shows the bus transaction protocol. The blue color represents the signal sent by the host and the green color stands for the signal sent by the device. Before the transaction starts, the host should make sure that the XSD device is not in the sleep mode. One method is to always send a 'break' signal before starting the transaction, as shown in Figure 10. If the device is not in the sleep mode, the 'break' signal is not mandatory. The 'break' pulse width may appear to be wider than what the host sends out because of the reason explained in Figure 3. The symbols in Figure 10 are explained in Table 7.

**TABLE 7. SYMBOLS IN THE BUS TRANSACTION PROTOCOL**

SYM	DESCRIPTION	MIN	TYP	MAX
IFG <sub>H</sub>	Host inter-frame gap	0 BT <sub>H</sub>		800ms
IFG <sub>D</sub>	Device inter-frame gap		1 BT <sub>D</sub>	
TA <sub>H</sub>	Host turn-around time	1 BT <sub>H</sub>		800ms
TA <sub>D</sub>	Device turn-around time		1 BT <sub>D</sub>	

**Passive CRC Support**

The CRC feature only supports the read transaction in the ISL6296. When the OPCODE in the instruction is '10', an 8-bit CRC is automatically calculated for the data bytes being transferred out. The CRC result is then appended after the last data byte is read out.

CRC is generated using the DOW CRC polynomial as follows:

$$\text{Polynom} = 1 + X^4 + X^5 + X^8 \tag{EQ. 1}$$

The CRC generation algorithm is logically illustrated in Figure 11. Prior to a new CRC calculation, the LFSR (linear feedback shift register) is initialized to zero. The read data to be transmitted out is concurrently shifted into the CRC calculator. After the actual data is transmitted out, the final content of the LFSR is the resulting CRC value. This value is transmitted out after the read data, with LSB being transmitted out first.

**(A) Multi-Byte Write Instruction.**

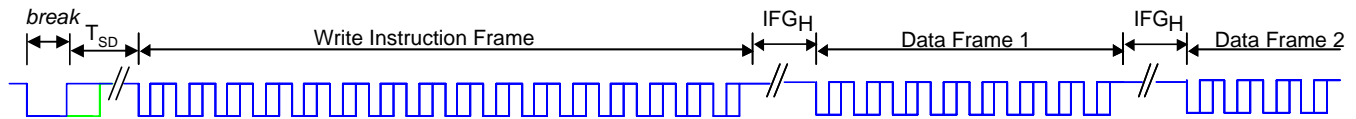

**(B) Multi-Byte Read Instruction.**

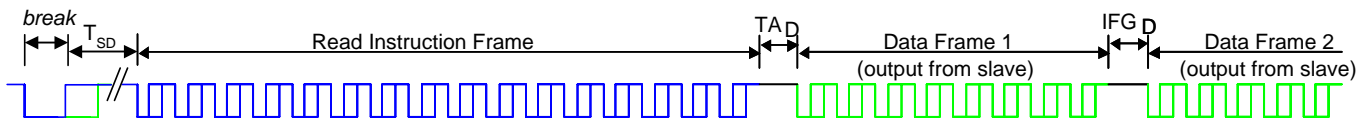

**(C) Back-to-Back Transaction (Read Followed by Write).**

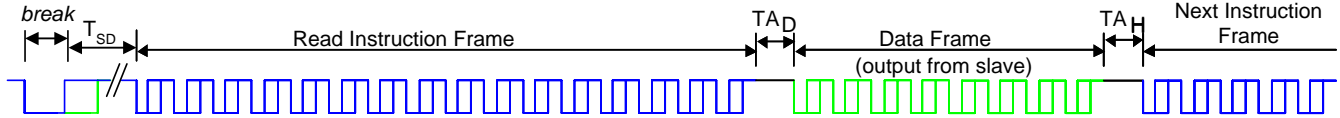

**FIGURE 10. XSD BUS TRANSACTION PROTOCOL. THE 'BREAK' SIGNAL IS OPTIONAL IF THE DEVICE IS AWAKE**

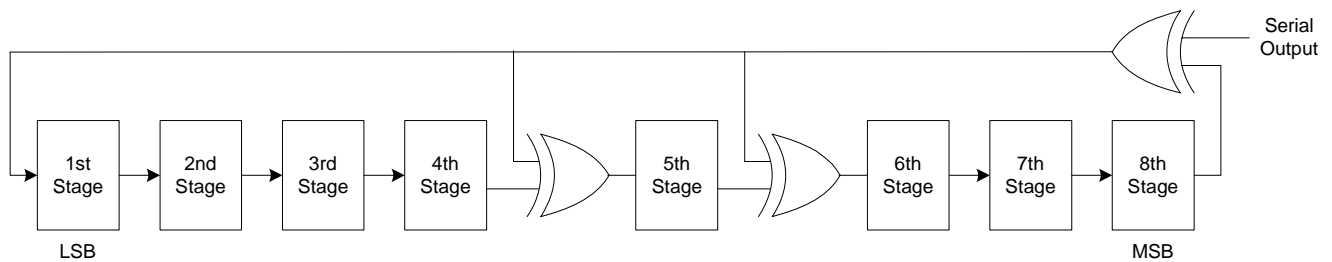

**FIGURE 11. THE CRC CALCULATOR FOR THE PASSIVE CRC SUPPORT**

**Analog Biasing Components and Clock Generation**

The analog section in the ISL6296 mainly includes the Time Base Generator and the internal regulator for powering the circuits in the ISL6296.

**TIME BASE GENERATOR**

A time base generator is included on-chip to provide timing reference for serial data encoding and decoding at the XSD bus interface. This eliminates the need for an external crystal. The time base oscillator is trimmed during manufacturing to a nominal frequency of 532.5kHz. It has a frequency tolerance better than 5% over operating supply voltage and temperature range.

**INTERNAL VOLTAGE REGULATOR**

The ISL6296 incorporates an internal voltage regulator that maintains a nominal operating voltage of 2.5V within the device. The regulator draws power directly from the  $V_{DD}$  input. No external component is required to regulate circuit voltage. The regulator is shut off during Sleep mode.

**Memory/Operational Register Description**

The ISL6296 memory and register structure is organized into 4 banks of 256 addressable locations. However, not all of the

addressable registers are used nor implemented. Accessing an unimplemented register will result in the access instruction being ignored. A bus error indication may or may not be flagged.

Bank 0 is dedicated for the OTP ROM. There are 16 memory locations implemented in the array. Writing to the OTP ROM has no immediate effect on the chip operation until a Power-on Reset occurred, or a soft reset is issued. Table 7 describes the OTP ROM memory assignment. The default factory setting for address [0:00] is given in Table 11.

Bank 1 contains the Control and Status registers. Only 2 registers are implemented. Table 8 shows the register map of the Bank 1 registers. Detailed description of register settings are given in Tables 14 and 15.

Bank 2 contains the Authentication registers. Only 3 registers are implemented. These registers are used during the battery pack authentication process. Table 10 describes the mapping of the Authentication registers.

Bank 3 is reserved for Intersil production testing only, and will not be accessible during normal operation. Accessing the Test and Trim Registers when not in test mode will result in a bus error.

**TABLE 8. OTP ROM MEMORY MAP (BANK 0)**

ADDRESS	NAME	DESCRIPTION	BIT 7	BIT 6	BIT 5	BIT 4	BIT3	BIT 2	BIT 1	BIT 0
0-00	DCFG	Default Configuration	DAB[1:0]		SPD[1:0]		eINT	ASLP	SLO[1:0]	
0-01	DTRM	Default Trimming	HSF	TIBB[2:0]			TOSC[3:0]			
0-02	SE1A	Auth Secret #1A	S1A[7:0]							
0-03	SE1B	Auth Secret #1B	S1B[7:0]							
0-04	SE1C	Auth Secret #1C	S1C[7:0]							
0-05	SE1D	Auth Secret #1D	S1D[7:0]							
0-06	SE2A	Auth Secret #2A	S2A[7:0]							
0-07	SE2B	Auth Secret #2B	S2B[7:0]							
0-08	SE2C	Auth Secret #2C	S2C[7:0]							
0-09	SE2D	Auth Secret #2D	S2D[7:0]							
0-0A	SE3A	Auth Secret #3A	S3A[7:0]							
0-0B	SE3B	Auth Secret #3B	S3B[7:0]							
0-0C	SE3C	Auth Secret #3C	S3C[7:0]							
0-0D	SE3D	Auth Secret #3D	S3D[7:0]							
0-0E	INF1	General Purpose	General purpose non-volatile memory for storage of model ID, date code, and other cell information							
0-0F	INF2	General Purpose								

NOTE: Information stored in address 0-0E (INF1) and 0-0F (INF2) is for use by the host firmware only. Actual content depends on the host firmware customization preference.

TABLE 9. CONTROL AND STATUS REGISTERS (BANK 1)

ADDRESS	NAME	DESCRIPTION	BIT 7	BIT 6	BIT 5	BIT 4	BIT3	BIT 2	BIT 1	BIT 0
1-00	MSCR	Master Control	eEEW	eINT	--	--	--	--	ASLP	SRST
1-01	STAT	Device Status	sEEW	sBER	sACC	--	DAB[1:0]		SLO[1:0]	

TABLE 10. AUTHENTICATION REGISTERS (BANK 2)

ADDRESS	NAME	DESCRIPTION	BIT 7	BIT 6	BIT 5	BIT 4	BIT3	BIT 2	BIT 1	BIT 0
2-00	SESL	Secrets Selection	--	--	--	--	CSL[1:0]		SSL[1:0]	
2-01	CHLG	Challenge Code Register	CHLG[31:0]							
2-05	AUTH	Authentication Code Register	AUTH[7:0]							

TABLE 11. DEFAULT CONFIGURATION (DCFG) REGISTER SETTINGS

BIT	NAME	TYPE	DEFAULT	DESCRIPTION
7:6	DAB[1:0]	RW	00	Device Address Bit Setting: 00 : device responds only when CS field in instruction frame is '0' 01 : device responds to any CS field value in instruction frame 10 : device responds to any CS field value in instruction frame 11 : device responds only when CS field in instruction frame is '1'
5:4	SPD[1:0]	RW	01	XSD Bus Speed Setting: Configures the bit rate of the XSD bus interface. 00 : 0.5x (2.89kbps) 01 : 1x (5.78kbps) 10 : 2x (11.56kbps) 11 : 4x (23.12kbps)
3	eINT	RW	1	Power-on default setting of eINT bit in the MSCR register.
2	ASLP	RW	1	Power-on default setting of ASLP bit in the MSCR register.
1:0	SLO[1:0]	RW	00	Secrets Lock-out Bits: Bit 1 : Read/Write lock-out bit for address locations 0-02 to 0-09 (Secret Set #1 and #2) Bit 0 : Read/Write lock-out bit for address locations 0-0A to 0-0D (Secret Set #3) <b>NOTE: Once Bit 0 or Bit 1 is set, writing to the OTP ROM will permanently be disabled (after a reset cycle).</b>

TABLE 12. DEFAULT TRIMMING (DTRM) REGISTER SETTINGS

BIT	NAME	TYPE	DEFAULT	DESCRIPTION
7	HSF	R	0	Unused
6:4	TIBB[2:0]	R	--	Reference Current Trim Setting
3:0	TOSC[3:0]	R	--	Oscillator Frequency Trim Setting

TABLE 13. LEGEND FOR THE TYPE COLUMN

TYPE		READ ACTION	WRITE ACTION
R	Read-only	Data read	Data ignored
W	Write-only	Zeros read	Data written
RW	Read/Write	Data read	Data written
RC	Clear after read	Data read, then cleared	Data ignored
WC	Clear after write	Zeros read	Data written, then cleared
<>	Default setting loaded from designated OTP ROM bit locations		
<u>W</u>	Writing disabled after lock-out		

**ADDRESS 0-00: DEFAULT CONFIGURATION (DCFG)**

This address location stores the default configuration when the ISL6296 is manufactured. Table 11 describes each bit in detail. The legend for the TYPE column is given in Table 13.

**ADDRESS 0-01: DEFAULT TRIM SETTING (DTRM)**

This address location is writable only when the device is in test mode. During normal operation, any data written to it will be ignored. Table 12 describes the DTRM address in detail.

**ADDRESS 0-02/03/04/05: AUTHENTICATION SECRET SET #1 (SE1A/B/C/D)**

These address locations store the first set of secrets to be used for hash calculation. Reading and writing to this register can be disabled by setting the SLO[1] bit at OTP ROM location 0-00[1].

**ADDRESS 0-06/07/08/09: AUTHENTICATION SECRET SET #2 (SE2A/B/C/D)**

These address locations store the second set of secrets to be used for hash calculation. Reading and writing to this register can be disabled by setting the SLO[1] bit at OTP ROM location 0-00[1].

**ADDRESS 0-0A/0B/0C/0D: AUTHENTICATION SECRET SET #3 (SE3A/B/C/D)**

These address locations store the optional third set of secrets to be used for hash calculation. Reading and writing to this register can be disabled by setting the SLO[0] bit at OTP ROM location 0-00[0].

Alternately, this memory space can be used to store additional cell information which can be accessed by the host. In this case, the SLO[0] bit should not be set.

**TABLE 14. MASTER CONTROL REGISTER (MSCR)**

BIT	NAME	TYPE	DEFAULT	DESCRIPTION
7	eEEW	R	0 <1/0>	OTP ROM Write-in-Progress Interrupt Enable: When enabled, it allows the sEEW bit to flag an interrupt whenever the sEEW bit is set by its interrupt event. The eEEW bit is fixed at '1' when none of the OTP ROM lock-out bits are set. When any or both of the lock-out bits are set, the eEEW bit will become permanently '0' after a reset.
6	eINT	RW	0 <1>	Global Interrupt Enable: When enabled, it allows the sBER or sACC bit to flag an interrupt to the host whenever any of the respective interrupt event occurred. (Default setting loaded from OTP ROM location 0-00[3])
5:2	--	R	0	Unused.
1	ASLP	RW	0 <1>	Auto Sleep Mode enable: When set, the ISL6296 will automatically enter Sleep mode after about 1s of XSD bus inactivity. When cleared, the device can only enter Sleep mode on Opcode command. (Default setting loaded from OTP ROM location 0-00[2])
0	SRST	WC	0	Soft Reset: When a '1' is written, and all registers are reset to their default states, all bus counters and timers are reset to their start-up conditions, and device configuration information is reloaded from OTP ROM. After the reset sequence is completed, a 'break' pulse is sent to the host.

**TABLE 15. DEVICE STATUS REGISTER (STAT)**

BIT	NAME	TYPE	DEFAULT	DESCRIPTION
7	sEEW	RC	0	OTP ROM Write-in-Progress Flag: This bit is set when attempt is made by the host to read from or write to the ISL6296 while the ROM is still processing the previous write instruction.
6	sBER	RC	0	XSD Bus Error Flag: This bit is set when one or more of the following occurred at the bus interface: a) An invalid pulse width is received b) Bus activity is detected before the device completes its power-up sequence c) An invalid BYTES field in the instruction frame d) Improper authentication sequence is detected e) Reading secret information after the corresponding lock-out bits are set
5	sACC	RC	0	Register Access Error Flag: This bit is set whenever an instruction frame attempts to access a protected register as follows: a) Writing to OTP ROM after the ISL6296 has been locked out (any or both of the lock-out bits set) b) Accessing the ISL6296's Test and Trim Registers when the device is not in test mode
4	--	R	0	Unused
3:2	DAB[1:0]	R	00 <00>	Device Address Bit Setting: Loaded from OTP ROM location 0-00[7:6] during power-up.
1:0	SLO[1:0]	R	00 <00>	Secrets Lock-out Bits Setting: Loaded from OTP ROM location 0-00[1:0] during power-up.



TABLE 16. SECRETS SELECTION REGISTER (SESL)

BIT	NAME	TYPE	DEFAULT	DESCRIPTION
7:4	--	R	0000	Unused
3:2	CSL[1:0]	RW	01	Coefficient Definition Secret Selection: Selects the authentication secret code word stored in OTP ROM to be used as the coefficient definition code for the FlexiHash engine. 00: invalid selection 01: Authentication Secret Set #1 10: Authentication Secret Set #2 11: Authentication Secret Set #3
1:0	SSL[1:0]	RW	10	Seed Secret Selection: Selects the authentication secret code word stored in OTP ROM to be used as the secret seed for the FlexiHash engine. 00: invalid selection 01: Authentication Secret Set #1 10: Authentication Secret Set #2 11: Authentication Secret Set #3

#### ADDRESS 0-0E/0F: GENERAL PURPOSE MEMORY (INF1/2)

These address locations can be used to store information like model ID, date code, and other cell information which can be read by the host.

#### ADDRESS 1-00: MASTER CONTROL REGISTER (MSCR)

The Master Control Register is defined in Table 14. The MSCR register can be both read or written by the host through the XSD bus.

#### ADDRESS 1-01: DEVICE STATUS REGISTER (STAT)

The STAT register is defined in Table 15. All status bits will be cleared upon a read to this register. The STAT is a read-only register.

#### ADDRESS 2-00: SECRETS SELECTION REGISTER (SESL)

This register must be written to re-load the hash engine with secrets stored in OTP ROM prior to presenting a new challenge code word input.

#### ADDRESS 2-01: CHALLENGE CODE INPUT REGISTER (CHLG)

This register is used to input the 32-bit challenge code generated by the host for device authentication. All four bytes of the challenge code should be written sequentially to this register, starting with the least-significant byte. After the fourth challenge byte is received, the authentication code generation process will start. This CHLG is a write-only register.

#### ADDRESS 2-05: AUTHENTICATION CODE OUTPUT REGISTER (AUTH)

This register is used to output the 8-bit authentication code calculated from the 32-bit challenge code. The register content may be read only once after each challenge code word is written to the device. Subsequent read to this register without a new challenge being input will result in an error condition.

## Applications Information

### XSD Bus Implementation

There are two ways to implement the XSD host in a micro-processor. One way is to use a spare Universal Asynchronous Receiver/Transmitter (UART). A general purpose input/output (GPIO) can be used if no UART is available for the XSD communication. Refer to application note AN1167 available from Intersil for more information regarding how to implement the XSD bus within a microprocessor.

### Pull-Up Resistor Selection

Since there is an internal pull-down current on the XSD pin, as shown in Figure 7, it is important to choose a pull-up resistor value that is low enough so that the small amount of pull-down current through the resistor does not cause the bus voltage to droop below the  $V_{IH}$  specification under any condition. 5k $\Omega$  is a typical resistance used for pull up.

### Powered by XSD Bus

In applications that the device supply voltage is lower than 2.6V (such as an application powered by a single-cell NiMH battery), or a device that has no power source at all, the ISL6296 can be powered by the XSD bus. The application circuit is shown in Figure 2. The condition for such application circuit to function properly is that the bus pull-up voltage is 3.3V or 5V. The bus pull-up voltage will charge the capacitor  $C_1$  through an internal ESD diode, as shown in Figure 7. The ESD diode has 0.4V drop typically.

### ESD Rating

The ISL6296 ESD specification is rated at 4kV of the human body model. When the ISL6296 is used in a hand-held accessory, higher ESD rating is typically required. External components are required to enhance the ESD performance.

### Additional Application Information

See Related Literature referenced on the first page for additional application information.

Small Outline Transistor Plastic Packages (SOT23-5)

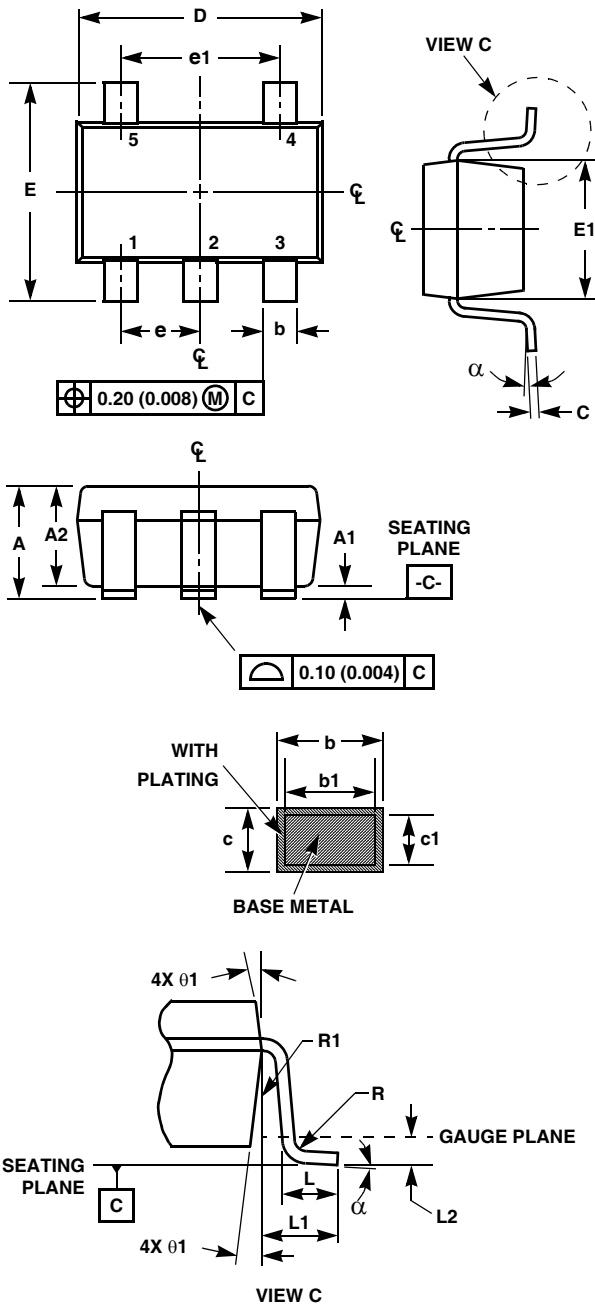

P5.064

5 LEAD SMALL OUTLINE TRANSISTOR PLASTIC PACKAGE

SYMBOL	INCHES		MILLIMETERS		NOTES
	MIN	MAX	MIN	MAX	
A	0.036	0.057	0.90	1.45	-
A1	0.000	0.0059	0.00	0.15	-
A2	0.036	0.051	0.90	1.30	-
b	0.012	0.020	0.30	0.50	-
b1	0.012	0.018	0.30	0.45	-
c	0.003	0.009	0.08	0.22	6
c1	0.003	0.008	0.08	0.20	6
D	0.111	0.118	2.80	3.00	3
E	0.103	0.118	2.60	3.00	-
E1	0.060	0.067	1.50	1.70	3
e	0.0374 Ref		0.95 Ref		-
e1	0.0748 Ref		1.90 Ref		-
L	0.014	0.022	0.35	0.55	4
L1	0.024 Ref.		0.60 Ref.		-
L2	0.010 Ref.		0.25 Ref.		-
N	5		5		5
R	0.004	-	0.10	-	-
R1	0.004	0.010	0.10	0.25	-
$\alpha$	0°	8°	0°	8°	-

Rev. 2 9/03

NOTES:

1. Dimensioning and tolerance per ASME Y14.5M-1994.
2. Package conforms to EIAJ SC-74 and JEDEC MO178AA.
3. Dimensions D and E1 are exclusive of mold flash, protrusions, or gate burrs.
4. Footlength L measured at reference to gauge plane.
5. "N" is the number of terminal positions.
6. These Dimensions apply to the flat section of the lead between 0.08mm and 0.15mm from the lead tip.
7. Controlling dimension: MILLIMETER. Converted inch dimensions are for reference only.

Thin Dual Flat No-Lead Plastic Package (TDFN)

L8.2x3A

8 LEAD THIN DUAL FLAT NO-LEAD PLASTIC PACKAGE

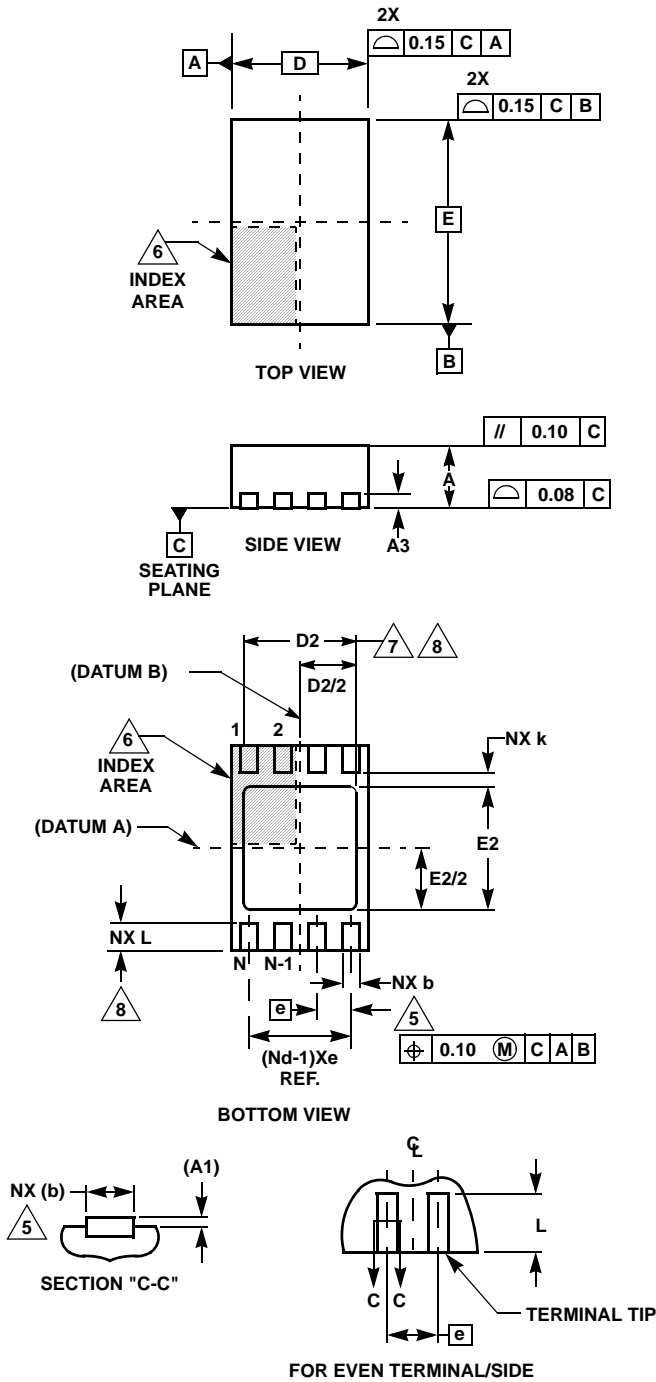

SYMBOL	MILLIMETERS			NOTES
	MIN	NOMINAL	MAX	
A	0.70	0.75	0.80	-
A1	-	-	0.05	-
A3	0.20 REF			-
b	0.20	0.25	0.32	5,8
D	2.00 BSC			-
D2	1.50	1.65	1.75	7,8
E	3.00 BSC			-
E2	1.65	1.80	1.90	7,8
e	0.50 BSC			-
k	0.20	-	-	-
L	0.30	0.40	0.50	8
N	8			2
Nd	4			3

Rev. 0 6/04

NOTES:

1. Dimensioning and tolerancing conform to ASME Y14.5-1994.
2. N is the number of terminals.
3. Nd refers to the number of terminals on D.
4. All dimensions are in millimeters. Angles are in degrees.
5. Dimension b applies to the metallized terminal and is measured between 0.25mm and 0.30mm from the terminal tip.
6. The configuration of the pin #1 identifier is optional, but must be located within the zone indicated. The pin #1 identifier may be either a mold or mark feature.
7. Dimensions D2 and E2 are for the exposed pads which provide improved electrical and thermal performance.
8. Nominal dimensions are provided to assist with PCB Land Pattern Design efforts, see Intersil Technical Brief TB389.

All Intersil U.S. products are manufactured, assembled and tested utilizing ISO9000 quality systems. Intersil Corporation's quality certifications can be viewed at [www.intersil.com/design/quality](http://www.intersil.com/design/quality)

Intersil products are sold by description only. Intersil Corporation reserves the right to make changes in circuit design, software and/or specifications at any time without notice. Accordingly, the reader is cautioned to verify that data sheets are current before placing orders. Information furnished by Intersil is believed to be accurate and reliable. However, no responsibility is assumed by Intersil or its subsidiaries for its use; nor for any infringements of patents or other rights of third parties which may result from its use. No license is granted by implication or otherwise under any patent or patent rights of Intersil or its subsidiaries.

For information regarding Intersil Corporation and its products, see [www.intersil.com](http://www.intersil.com)