

ISL9506

Multiphase PWM Controller with Programmable Output Voltage

FN6722
Rev 0.00
August 13, 2008

The ISL9506 is a multiphase PWM buck controller for high performance digital processor core. This multiphase buck controller uses interleaved channels to reduce the total output voltage ripple with each channel carrying a portion of total load current. The multiple phase implementation results in better system performance, superior thermal management, lower component cost, reduced power dissipation, and smaller implementation area. The ISL9506 multiphase controller together with ISL6208 external gate drivers provide a complete solution to power the processor core. The PWM modulator of ISL9506 is based on Intersil's Robust Ripple Regulator technology (R³). Compared with the traditional multiphase buck regulator, the R³ modulator commands variable switching frequency during load transients, which achieves faster transient response. With the same modulator, the switching frequency is reduced at light load conditions resulting higher operation efficiency.

ISL9506 responds to LP (Low Power) signal by adding or dropping PWM2 and adjusting overcurrent protection accordingly. ISL9506 enables diode emulation and stretches switching period at light load conditions to improve efficiency. The diode emulation feature is programmed by DE_EN (Diode Emulation Enable) and DE_ENN pins.

The ISL9506 has several other key features. ISL9506 reports output power through a power monitor pin (PMON). Current sense can be achieved by using either inductor DCR or discrete precision resistor. In the case of DCR current sensing, a single NTC thermistor is used to thermally compensate the inductor DCR variation with temperature. A unity gain, differential amplifier is available for remote voltage sensing. This allows the voltage at the load point to be accurately measured and regulated per voltage selection pins.

Ordering Information

PART NUMBER (Note)	PART MARKING	TEMP. RANGE (°C)	PACKAGE (Pb-Free)	PKG. DWG. #
ISL9506HRZ	ISL9506 HRZ	-10 to +100	40 Ld 6x6 QFN	L40.6x6
ISL9506HRZ-T	ISL9506 HRZ	-10 to +100	40 Ld 6x6 QFN Tape and Reel	L40.6x6

*Please refer to TB347 for details on reel specifications.

NOTE: These Intersil Pb-free plastic packaged products employ special Pb-free material sets, molding compounds/die attach materials, and 100% matte tin plate plus anneal (e3 termination finish, which is RoHS compliant and compatible with both SnPb and Pb-free soldering operations). Intersil Pb-free products are MSL classified at Pb-free peak reflow temperatures that meet or exceed the Pb-free requirements of IPC/JEDEC J STD-020.

Features

- Precision Multiphase Voltage Regulation
 - 0.5% System Accuracy Over Temperature
 - Enhanced Droop Impedance Accuracy
- Voltage Selection Input
 - 7-Bit VSEL (Voltage Selection) Input
 - 0.300V to 1.500V in 12.5mV Steps
 - Supports VSEL Changes On-The-Fly
- Multiple Current Sensing Approaches Supported
 - Lossless DCR Current Sensing
 - Precision Resistive Current Sensing
- Optimized Efficiency across Overall Load Range
- Superior Noise Immunity and Transient Response
- Power Monitor and Thermal Monitor
- Differential Remote Voltage Sensing
- Programmable 1, 2 or 3 Power Channels
- Excellent Dynamic Current Balance between Channels
- Small Footprint 40 Ld 6x6 QFN Package
- Pb-Free (RoHS compliant)

Applications

- Mobile Laptop Computers
- High Performance Point-of-Load Power Supply

Pinout

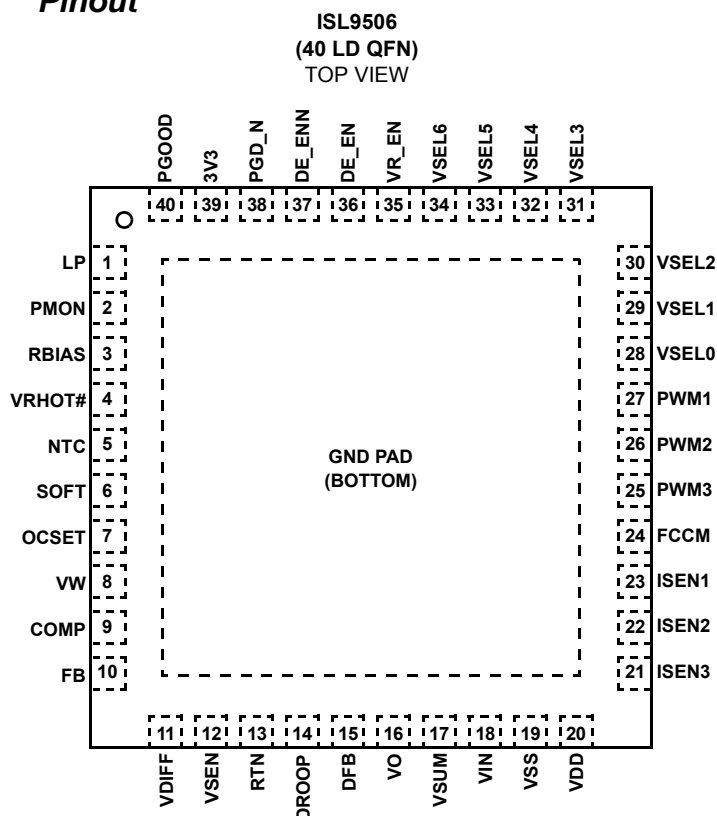

Functional Pin Description

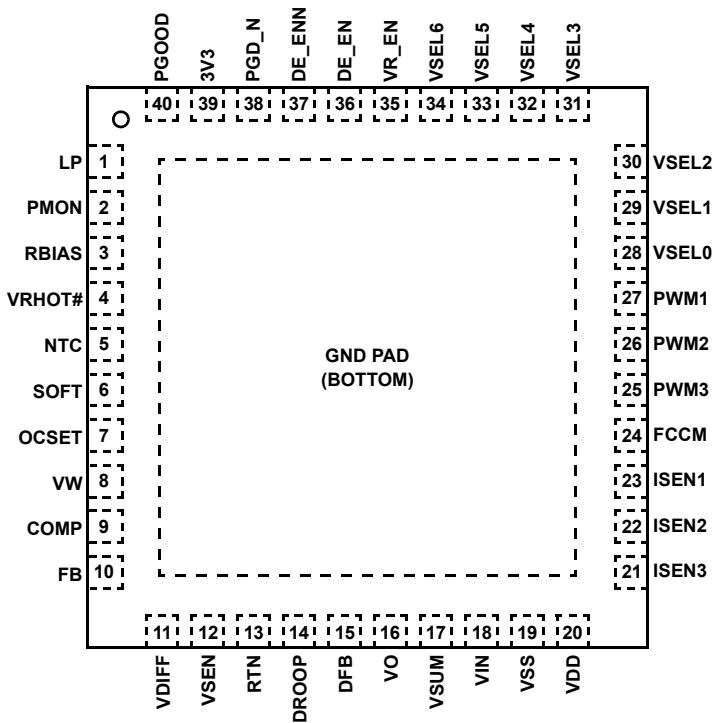

LP (Pin 1)

Low power indicator input. When asserted low, indicates a reduced load-current condition. For ISL9506, when LP is asserted low, PWM2 will be disabled.

PMON (Pin 2)

An analog output. PMON sends out an analog signal proportional to the product of VSEN voltage and the droop voltage.

RBIAS (Pin 3)

Connect a 147k Resistor to VSS, sets the internal current reference.

VRHOT# (Pin 4)

Thermal overload output indicator.

NTC (Pin 5)

Thermistor input to VRHOT# circuit.

SOFT (Pin 6)

A capacitor from this pin to VSS sets the maximum slew rate of the output voltage. It affects both soft start and VSEL transitioning slew rate. SOFT pin is the non-inverting input of the error amplifier.

OCSET (Pin 7)

Overcurrent set input. A resistor from this pin to VO sets DROOP voltage limit for OC trip. A 10 μ A current source is connected internally to this pin.

VW (Pin 8)

A resistor from this pin to COMP programs the switching frequency. (7k Ω gives approximately 300kHz). VW pin sources current.

COMP (Pin 9)

This pin is the output of the error amplifier.

FB (Pin 10)

This pin is the inverting input of error amplifier.

VDIFF (Pin 11)

This pin is the output of the differential amplifier.

VSEN (Pin 12)

Remote output voltage sense input. Connect to the point of load.

RTN (Pin 13)

Remote voltage sensing return. Connect to ground at the point of load.

DROOP (Pin 14)

Output of droop amplifier. Output = VO + DROOP.

DFB (Pin 15)

Inverting input to droop amplifier.

VO (Pin 16)

An input to the IC that reports the local output voltage.

VSUM (Pin 17)

This pin is connected to the current summation junction.

VIN (Pin 18)

Battery supply voltage, used for feed forward.

VSS (Pin 19)

Signal ground; Connect to local controller ground.

VDD (Pin 20)

5V bias power.

ISEN3 (Pin 21)

Individual current sensing for Channel 3.

ISEN2 (Pin 22)

Individual current sensing for Channel 2.

ISEN1 (Pin 23)

Individual current sensing for Channel 1.

FCCM (Pin 24)

Forced Continuous Conduction Mode (FCCM) enable pin to MOSFET drivers. It will disable diode emulation.

PWM3 (Pin 25)

PWM output for Channel 3. When PWM3 is pulled to 5V VDD, PWM3 will be disabled and allow other channels to operate.

PWM2 (Pin 26)

PWM output for Channel 2. For ISL9506, LP low will make this output tri-state. When PWM2 is pulled to 5V VDD, PWM2 will be disabled and allow other channels to operate.

PWM1 (Pin 27)

PWM output for channel 1.

VSEL0:6 (Pin28:Pin34)

Voltage Selection input with VSEL0 = LSB and VSEL6 = MSB.

VR_EN (Pin 35)

Voltage Regulator Enable input. A high level logic signal on this pin enables the regulator.

DE_EN (Pin 36)

Diode Emulation Enable signal. A high level logic signal on this pin will allow diode emulation operation. Only if the current is low enough, the diode emulation will actually be entered. DE_EN logic high also affects the output voltage transition from one voltage selection to another programmed by voltage select.

DE_ENN (Pin 37)

DE_EN and DE_ENN work together for diode emulation. Generally a reversed logic signal of DE_EN should be applied to DE_ENN.

PGD_N (Pin 38)

Digital output prior to PGOOD high. Goes nominal (logic 0) after 13 switching cycles after V_{OUT} is within 10% of 1.2V voltage at start-up.

3V3 (Pin 39)

3.3V supply voltage for PGD_N logic, such an implementation will increase power consumption from 3.3V compared to open drain circuit other wise.

PGOOD (Pin 40)

Power Good open-drain output. Will be pulled up externally by a 1.9kΩ resistor to 3.3V.

Absolute Maximum Ratings

Supply Voltage, V_{DD}	-0.3 to +7V
Battery Voltage, V_{IN}	+25V
Open Drain Outputs, PGOOD, VRHOT#	-0.3 to +7V
All Other Pins	-0.3V to ($V_{DD} + 0.3V$)

Operating Conditions

Temperature Range	-10°C to +100°C
Supply Voltage Range (Typical)	+5V \pm 5%

CAUTION: Do not operate at or near the maximum ratings listed for extended periods of time. Exposure to such conditions may adversely impact product reliability and result in failures not covered by warranty.

NOTES:

- θ_{JA} is measured with the component mounted on a low effective thermal conductivity test board in free air. See Tech Brief TB379 for details.
- For θ_{JC} , the "case temp" location is the center of the exposed metal pad on the package underside.
- Limits established by characterization and are not production tested.

Thermal Information

Thermal Resistance (Notes 1, 2)	θ_{JA} (°C/W)	θ_{JC} (°C/W)
40 Ld QFN Package	30	5.5
Maximum Junction Temperature	+150°C	
Storage Temperature	-65°C to +150°C	
Pb-Free Reflow Profile	see link below	
	http://www.intersil.com/pbfree/Pb-FreeReflow.asp	

Electrical Specifications Operating Conditions: $V_{DD} = 5V$, $T_A = -10^\circ\text{C}$ to $+100^\circ\text{C}$, unless otherwise noted. Parameters with MIN and/or MAX limits are 100% tested at $+25^\circ\text{C}$, unless otherwise specified. Temperature limits established by characterization and are not production tested.

PARAMETER	SYMBOL	TEST CONDITIONS	MIN	TYP	MAX	UNITS
INPUT POWER SUPPLY						
+5V Supply Current	I_{VDD}	VR_EN = 3.3V		3.6	4.2	mA
		VR_EN = 0V			1	μA
+3.3V Supply Current	I_{3V3}	No load on PGD_N			1	μA
Battery Supply Current	I_{VIN}	VR_EN = 0V			1	μA
V_{IN} Input Resistance	R_{VIN}	VR_EN = 3.3V		900		$\text{k}\Omega$
Power-On-Reset Threshold	POR_r	V_{DD} rising		4.35	4.5	V
	POR_f	V_{DD} falling	4.00	4.15		V
SYSTEM AND REFERENCES						
System Accuracy	%Error (V_{OUT})	No load; closed loop, nominal mode range VSEL = 0.75V to 1.50V	-0.5		+0.5	%
		VSEL = 0.5V to 0.7375V	-8		+8	mV
		VSEL = 0.3 to 0.4875V	-15		+15	mV
V_{START}			1.176	1.200	1.224	V
Maximum Output Voltage	$V_{OUT(max)}$	VSEL = [0000000]		1.500		V
Minimum Output Voltage	$V_{OUT(min)}$	VSEL = [1100000]		0.300		V
VSEL Off State		VSEL = [1111111]		0.0		V
R_{BIAS} Voltage		$R_{BIAS} = 147\text{k}\Omega$	1.45	1.47	1.49	V
CHANNEL FREQUENCY						
Nominal Channel Frequency	$f_{SW(nom)}$	$R_{FSET} = 7\text{k}\Omega$, 3 channel operation, $V_{COMP} = 2V$	285	300	315	kHz
Adjustment Range		See Equation 6 R_{FSET} selection	200		500	kHz
AMPLIFIERS						
Droop Amplifier Offset			-0.3		+0.3	mV
Error Amp DC Gain	A_{V0}	(Note 3)		90		dB
Error Amp Gain-Bandwidth Product	GBW	$C_L = 20\text{pF}$ (Note 3)		18		MHz
FB Input Current	$I_{IN(FB)}$			10	150	nA

Electrical Specifications Operating Conditions: VDD = 5V, T_A = -10°C to +100°C, unless otherwise noted. Parameters with MIN and/or MAX limits are 100% tested at +25°C, unless otherwise specified. Temperature limits established by characterization and are not production tested. **(Continued)**

PARAMETER	SYMBOL	TEST CONDITIONS	MIN	TYP	MAX	UNITS
ISEN						
Imbalance Voltage		Maximum of ISENs - Minimum of ISENs			2	mV
Input Bias Current				20		nA
SOFT CURRENT						
Soft-start Current	I _{SS}		-47	-42	-37	μA
SOFT Geyserville Current	I _{GV}	SOFT-VDAC >100mV	±180	±205	±230	μA
SOFT DIODE EMULATION Entry Current	I _{C4}	DE_EN = 3.3V	-47	-42	-37	μA
SOFT DIODE EMULATION Exit Current	I _{C4EA}	DE_EN = 3.3V	37	42	47	μA
SOFT DIODE EMULATION Exit Current	I _{C4EB}	DE_EN = 0V	180	205	230	μA
POWER GOOD AND PROTECTION MONITORS						
PGOOD Low Voltage	V _{OL}	I _{PGOOD} = 4mA		0.26	0.4	V
PGOOD Leakage Current	I _{OH}	PGOOD = 3.3V	-1		1	μA
PGOOD Delay	t _{pgd}	PGD_N LOW to PGOOD HIGH	6.3	7.6	8.9	ms
Overvoltage Threshold	OV _H	VO rising above setpoint for >1ms	160	200	240	mV
Severe Overvoltage Threshold	OV _{HS}	VO rising for >2μs	1.675	1.7	1.725	V
OCSET Reference Current		I(R _{BIAS}) = 10μA	9.8	10	10.2	μA
OC Threshold Offset		DROOP rising above OCSET for >150μs	-2		4	mV
Current Imbalance Threshold		One ISEN above another ISEN for >1.2ms		9		mV
Undervoltage Threshold (VDIFF/SOFT)	UV _f	VO falling below setpoint for >1.2ms	-355	-295	-235	mV
LOGIC THRESHOLDS						
VR_EN and DE_EN Input Low	V _{IL(3.3V)}				1.0	V
VR_EN and DE_EN Input High	V _{IH(3.3V)}		2.3			V
VSEL0: VSEL6, LP, DE_ENN Input Low	V _{IL(1.0V)}				0.3	V
VSEL0: VSEL6, LP, DE_ENN Input High	V _{IH(1.0V)}		0.7			V
PWM						
PWM (PWM1 to PWM3) Output Low	V _{OL(5.0V)}	Sinking 5mA			1.0	V
FCCM Output Low	V _{OL_FCCM}	Sinking 3mA			1.0	V
PWM (PWM1 to PWM3) and FCCM Output High	V _{OH(5.0V)}	Sourcing 5mA	3.5			V
PWM Tri-State Leakage		PWM = 2.5V	-1		1	μA
THERMAL MONITOR						
NTC Source Current		NTC = 1.3V	53	60	67	μA
Over-Temperature Threshold		V (NTC) falling	1.18	1.2	1.22	V
VRHOT# Low Output Resistance	R _{TT}	I = 20mA		6.5	9	Ω

Electrical Specifications

Operating Conditions: VDD = 5V, TA = -10°C to +100°C, unless otherwise noted. Parameters with MIN and/or MAX limits are 100% tested at +25°C, unless otherwise specified. Temperature limits established by characterization and are not production tested. **(Continued)**

PARAMETER	SYMBOL	TEST CONDITIONS	MIN	TYP	MAX	UNITS
PGD_N OUTPUT LEVELS						
PGD_N High Output Voltage	V _{OH}	3V3 = 3.3V, I = -4mA	2.9	3.1		V
PGD_N Low Output Voltage	V _{OL}	I = 4mA		0.26	0.4	V
POWER MONITOR						
PMON Output Voltage	V _{PMON}	VSEN = 1.2V, Droop - Vo = 80mV	1.638	1.68	1.722	V
		VSEN = 1.0V, Droop - Vo = 20mV	0.308	0.35	0.392	V
PMON Maximum Voltage	V _{PMONMAX}		2.8	3		V
PMON Sourcing Current		VSEN = 1.0V, Droop - Vo = 50mV	2.0			mA
PMON Sinking Current		VSEN = 1.0V, Droop-Vo = 50mV	2.0			mA
Maximum Current Sinking Capability		See Figure 36	V _{PMON} /250	V _{PMON} /180	V _{PMON} /130	A
PMON Impedance		When PMON is within its sourcing/sinking current range (Note 3)		7		Ω

Typical Operating Performance 3-Phase, DCR Sense, HS one IRF7821, LS two IRF7832 per phase, 300kHz, 0.5μH

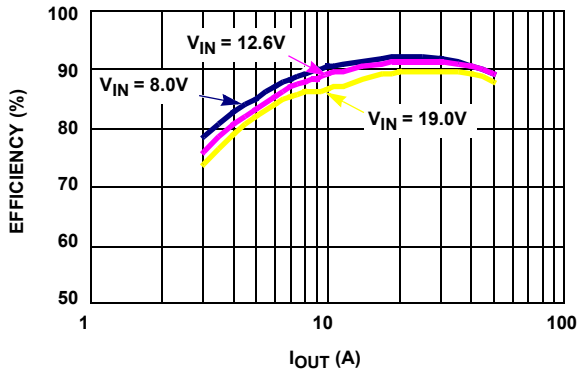

FIGURE 1. NOMINAL MODE EFFICIENCY, 3 PHASE, CCM, LP = HIGH, V_{SEL} = 1.4375V

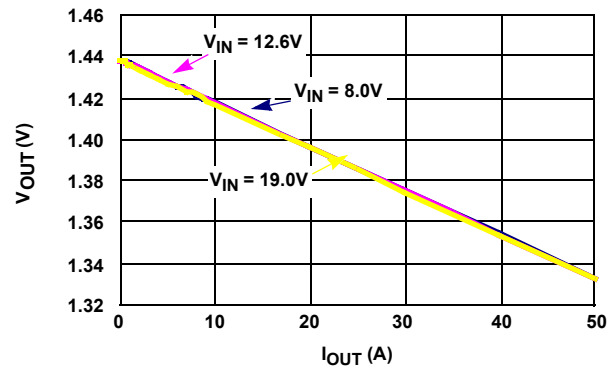

FIGURE 2. DROOP IMPEDANCE, 3 PHASE, CCM, LP = HIGH V_{SEL} = 1.435V

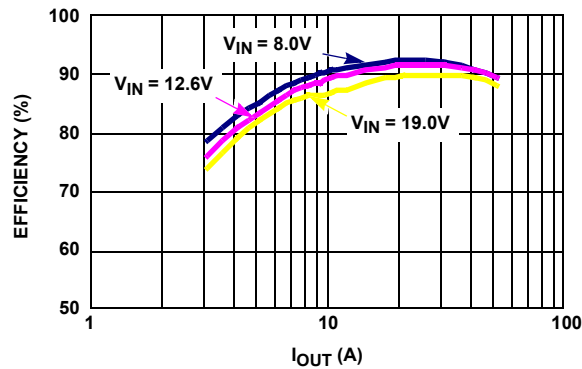

FIGURE 3. DIODE EMULATION MODE EFFICIENCY, 3 PHASE, DCM OPERATION, LP = LOW, V_{SEL} = 1.4375V

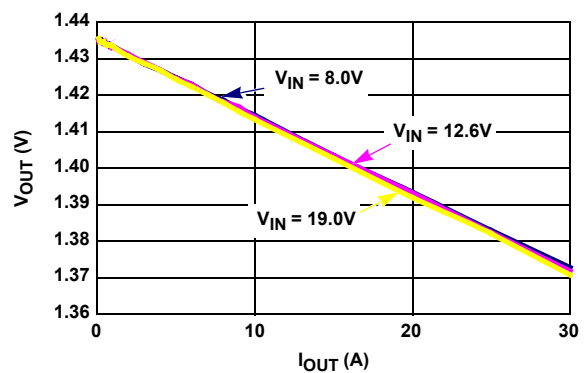

FIGURE 4. DIODE EMULATION MODE DROOP IMPEDANCE, 3 PHASE, CCM, LP = LOW V_{SEL} = 1.435V

Typical Operating Performance 3-Phase, DCR Sense, HS one IRF7821, LS two IRF7832 per phase, 300kHz, 0.5μH

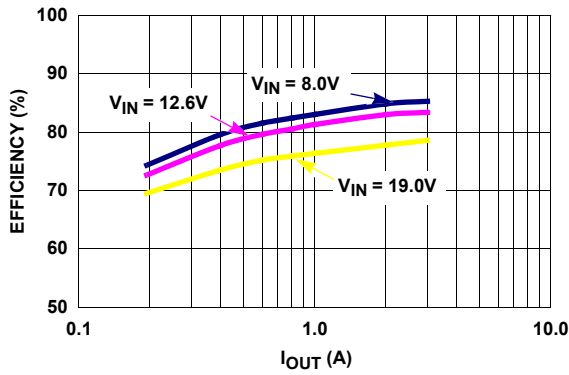

FIGURE 5. DIODE EMULATION MODE EFFICIENCY, 3 PHASE, DCM OPERATION, LP = LOW, VSEL = 0.75V

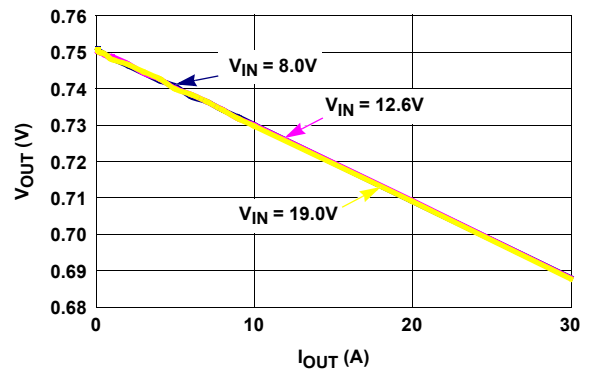

FIGURE 6. DIODE EMULATION MODE DROOP IMPEDANCE, 3 PHASE, DCM OPERATION, LP = LOW, VSEL = 0.75V

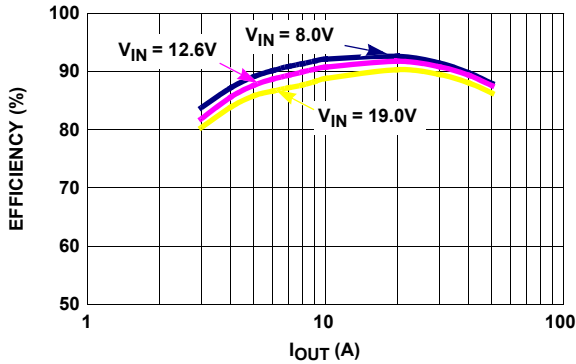

FIGURE 7. NOMINAL MODE EFFICIENCY, 2 PHASE, CCM, LP = HIGH, VSEL = 1.4375V

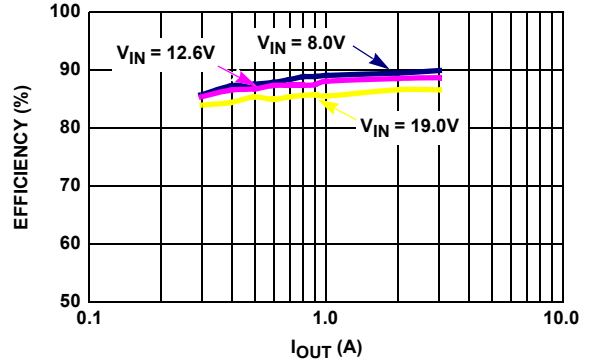

FIGURE 8. DIODE EMULATION MODE EFFICIENCY, 2 PHASE, DCM OPERATION, LP = LOW, VSEL = 1.4375V

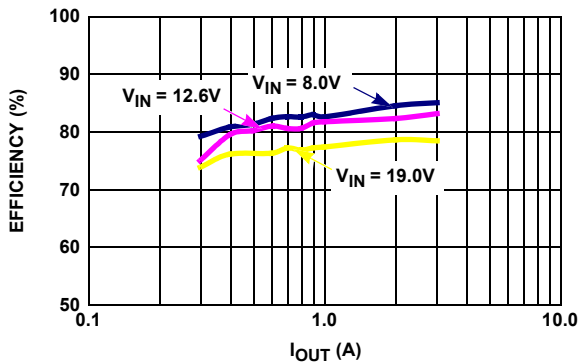

FIGURE 9. DIODE EMULATION MODE EFFICIENCY, 2 PHASE, DCM OPERATION, LP = LOW, VSEL = 0.75V

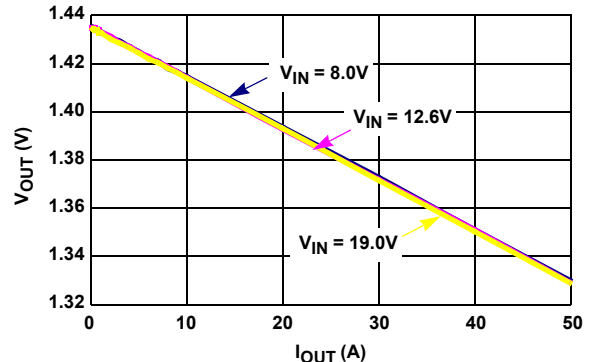

FIGURE 10. NOMINAL MODE DROOP IMPEDANCE, 2 PHASE, CCM, LP = HIGH, VSEL = 1.435V

Typical Operating Performance 3-Phase, DCR Sense, HS one IRF7821, LS two IRF7832 per phase, 300kHz, 0.5μH

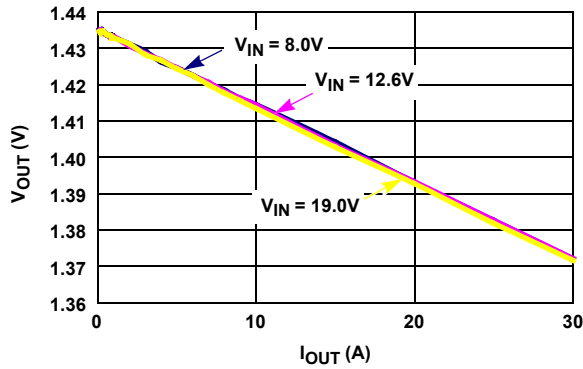

FIGURE 11. DIODE EMULATION MODE DROOP IMPEDANCE, 2 PHASE, DCM OPERATION, LP = LOW, VSEL = 1.4375V

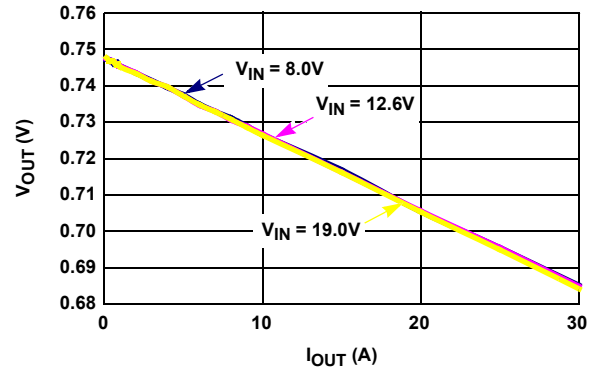

FIGURE 12. DIODE EMULATION MODE DROOP IMPEDANCE, 2 PHASE, DCM OPERATION, LP = LOW, VSEL = 0.75V

Typical Operating Performance

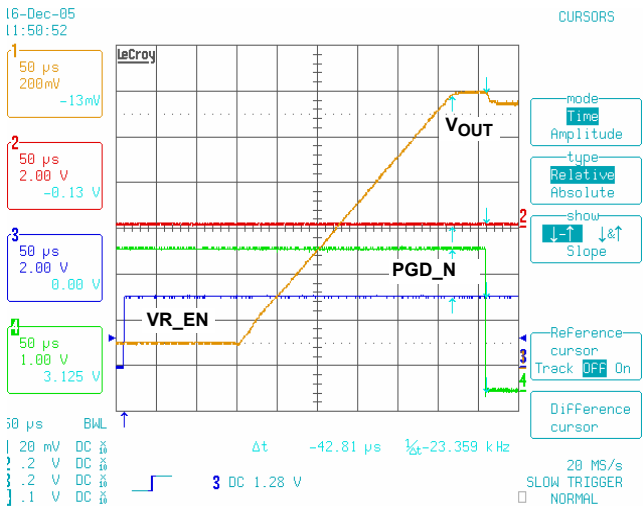

FIGURE 13. SOFT-START WAVEFORM 0V TO 1.2V (START VOLTAGE) AND PGD_N TIMING

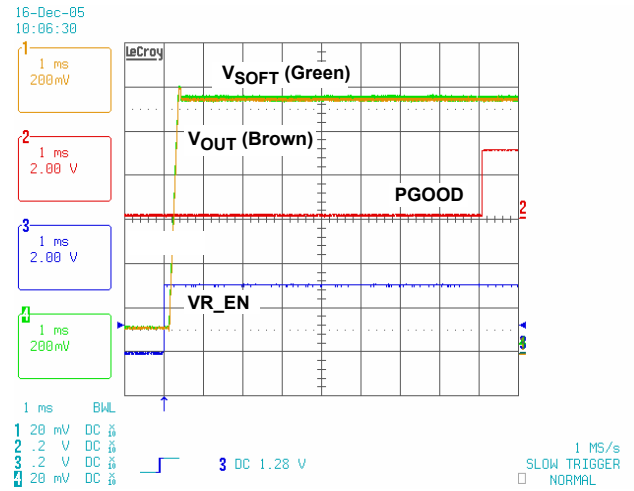

FIGURE 14. SOFT-START WAVEFORM SHOWING PGOOD

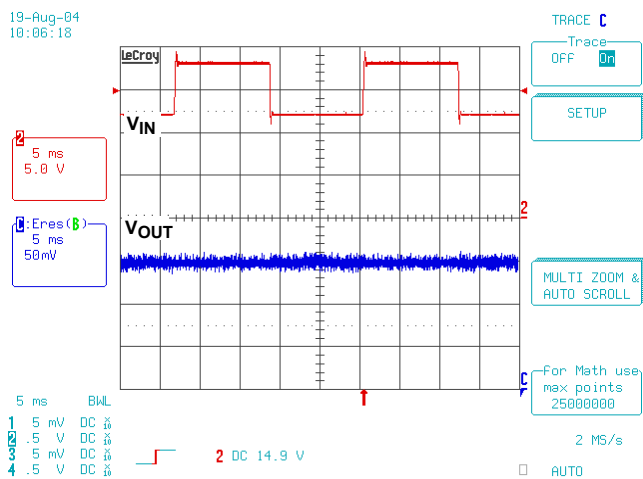

FIGURE 15. 12V-18V INPUT LINE TRANSIENT RESPONSE

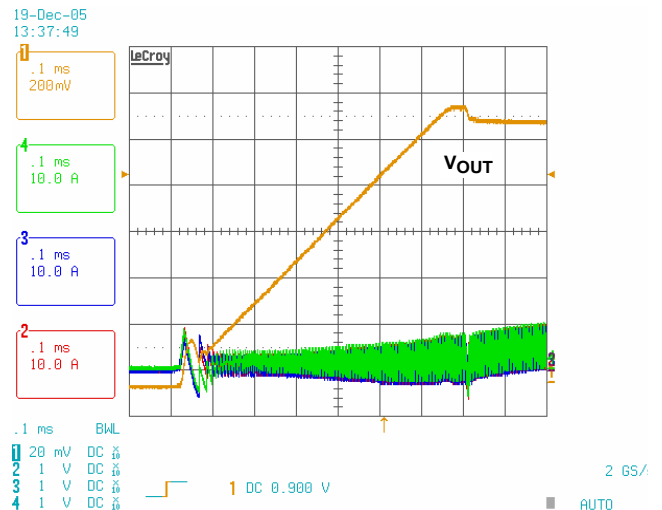

FIGURE 16. SOFT-START INRUSH CURRENT, VIN = 8V

Typical Operating Performance (Continued)

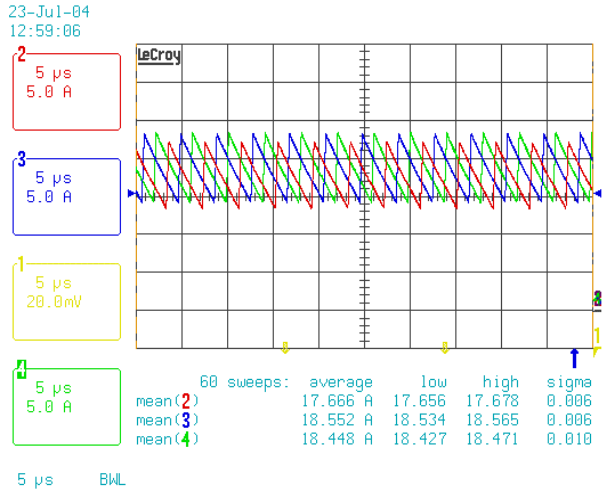

FIGURE 17. 3 PHASE CURRENT BALANCE, FULL LOAD = 50A

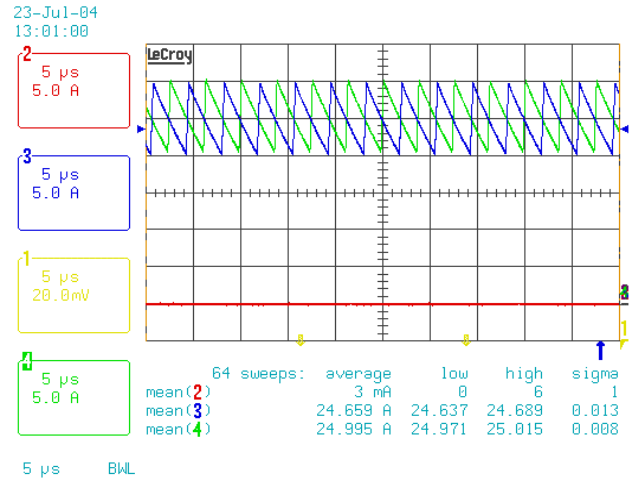

FIGURE 18. 2 PHASE CURRENT BALANCE, FULL LOAD = 50A

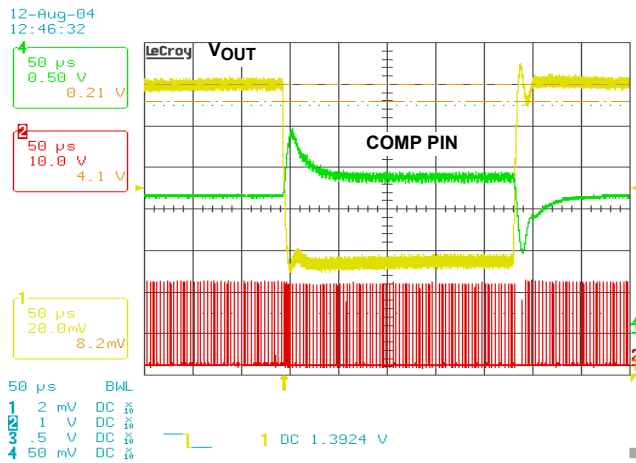

FIGURE 19. TRANSIENT LOAD RESPONSE, 40A LOAD STEP @ 200A/μs, 3 PHASE

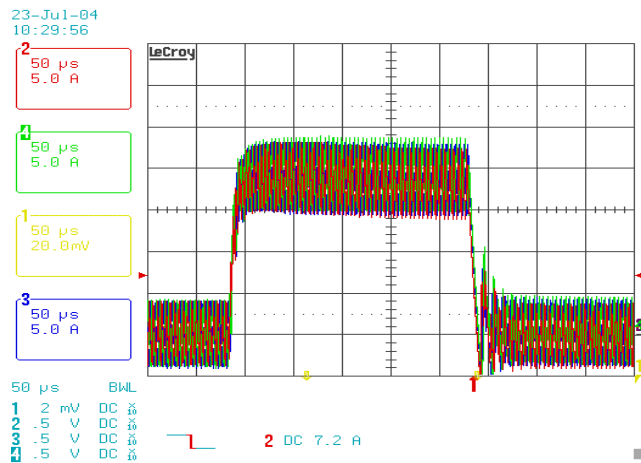

FIGURE 20. TRANSIENT LOAD 3 PHASE OPERATION - CURRENT BALANCE

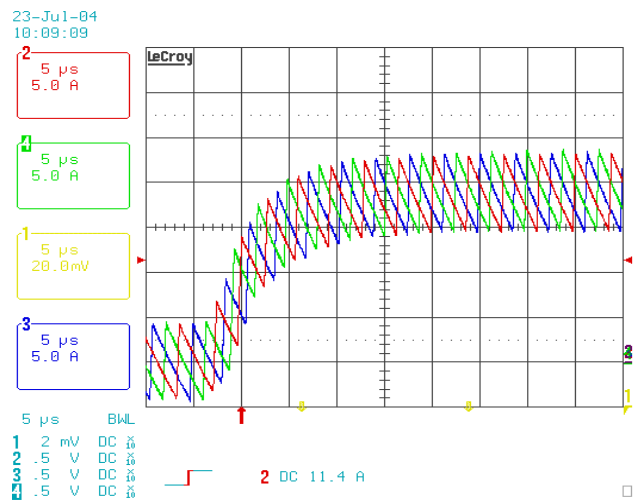

FIGURE 21. TRANSIENT LOAD 3 PHASE OPERATION, ZOOM OF RISING EDGE CURRENT BALANCE

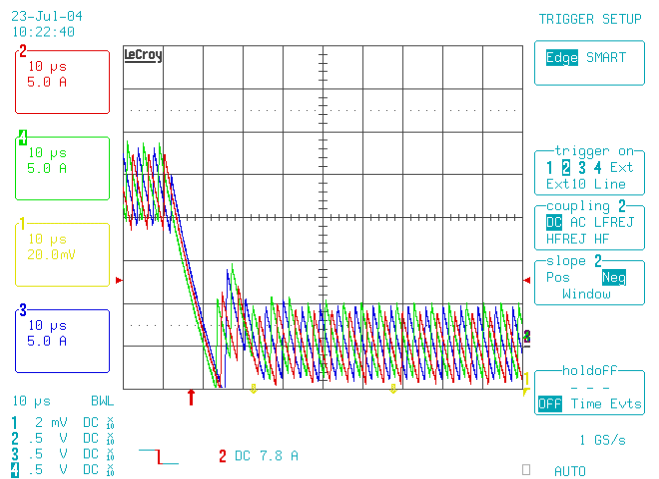

FIGURE 22. TRANSIENT LOAD 3 PHASE OPERATION, ZOOM OF FALLING EDGE CURRENT BALANCE

Typical Operating Performance (Continued)

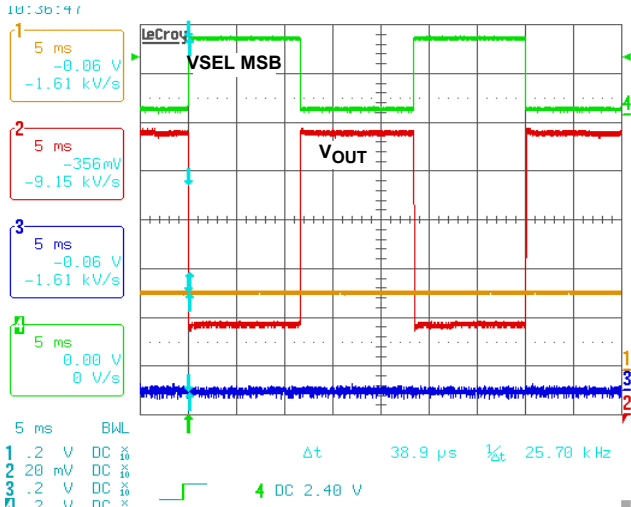

FIGURE 23. VSEL MSB BIT CHANGE FROM 1.4375V TO 0.65V SHOWING 9mV/μs SLEW RATE, DE_EN = 0, DE_ENN = 1

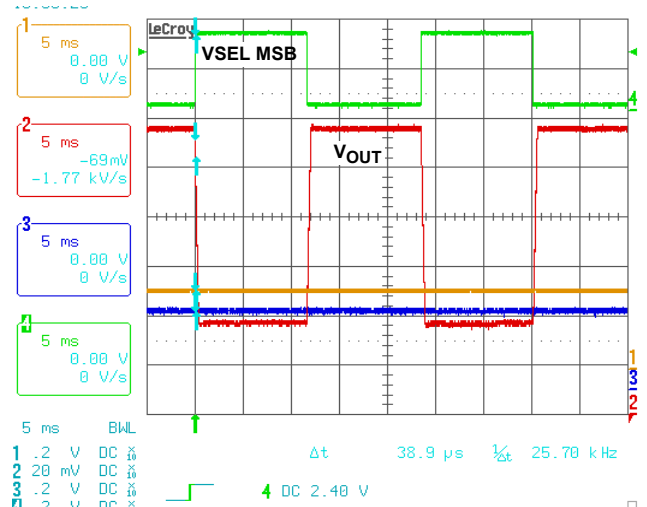

FIGURE 24. SLEW RATE ENTERING C4, VSEL MSB BIT CHANGE FROM 1.4375V TO 0.65V SHOWING 2mV/μs SLEW RATE, DE_EN = 1, DE_ENN = 0

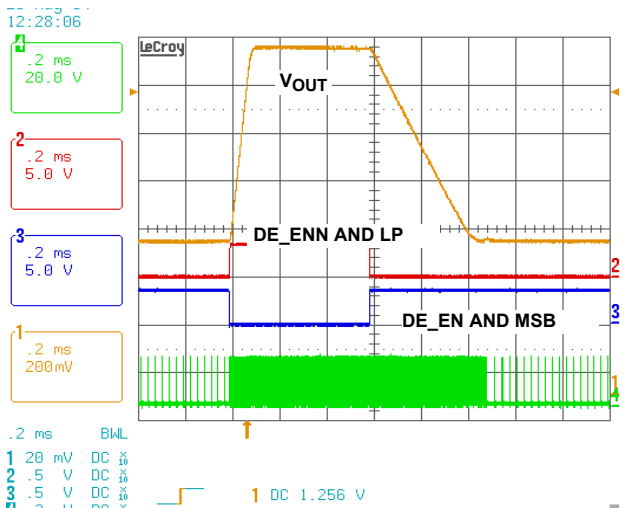

FIGURE 25. C4 ENTRY AND EXIT SLEW RATES WITH DE_EN AND DE_ENN

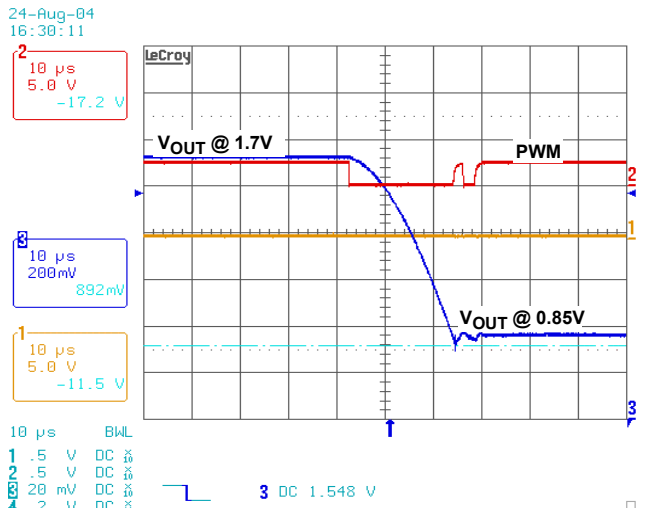

FIGURE 26. 1.7V OVP SHOWING OUTPUT PULLED LOW TO 0.85V AND PWM TRI_STATE

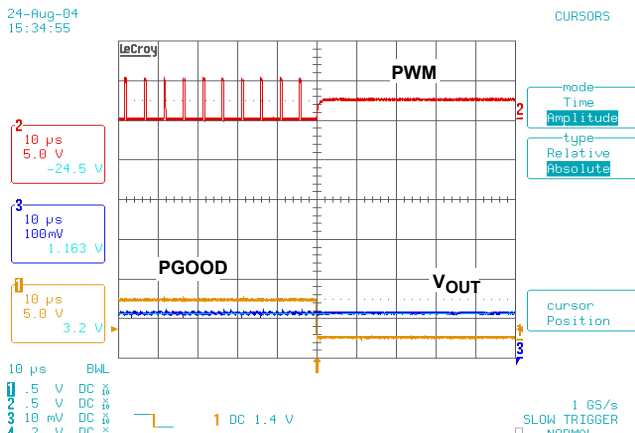

FIGURE 27. UNDERVOLTAGE RESPONSE SHOWING PWM TRI-STATE, VOUT < VSEL - 300mV

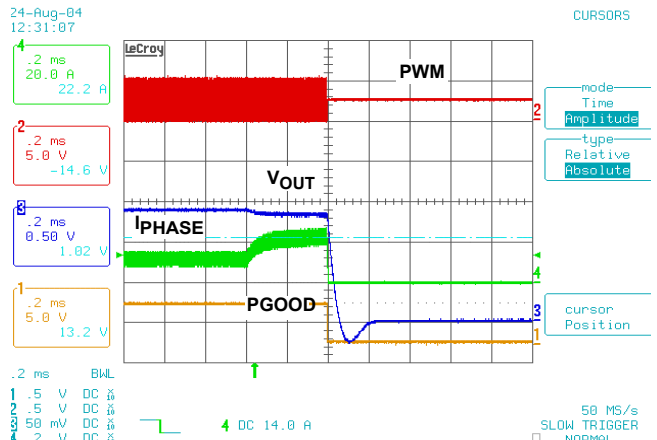

FIGURE 28. OCP - RESPONSE

Typical Operating Performance (Continued)

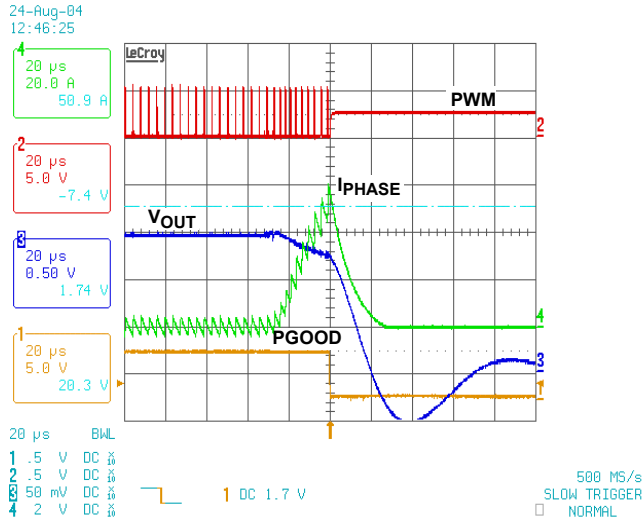

FIGURE 29. WSCP - SHORT CIRCUIT PROTECTION

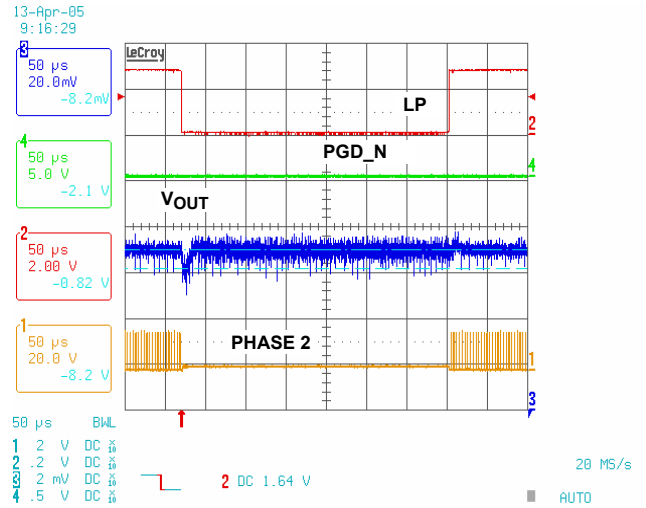

FIGURE 30. ISL9506, PHASE ADDING AND DROPPING IN NOMINAL MODE, LOAD CURRENT = 15A

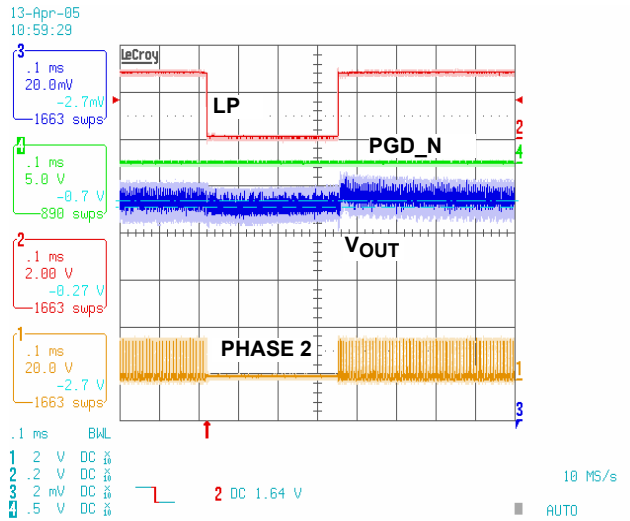

FIGURE 31. ISL9506 PHASE ADDING AND DROPPING IN DIODE EMULATION MODE, LOAD CURRENT = 4.35A

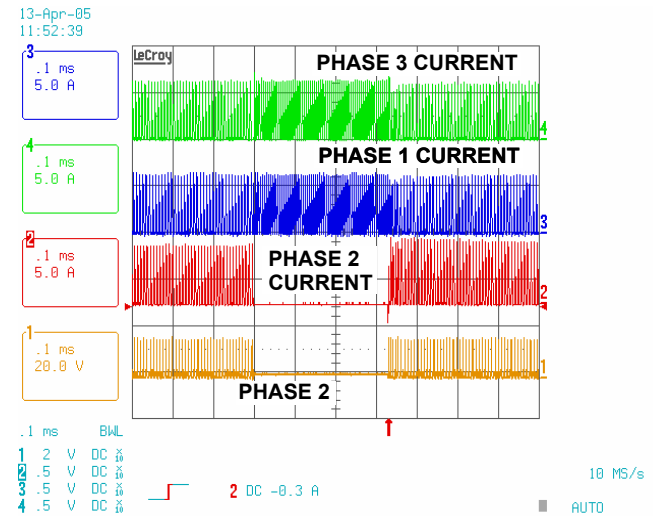

FIGURE 32. ISL9506, INDUCTOR CURRENT WAVEFORM WITH PHASE ADDING AND DROPPING IN DCM OR DIODE EMULATION MODE

Typical Operating Performance (Continued)

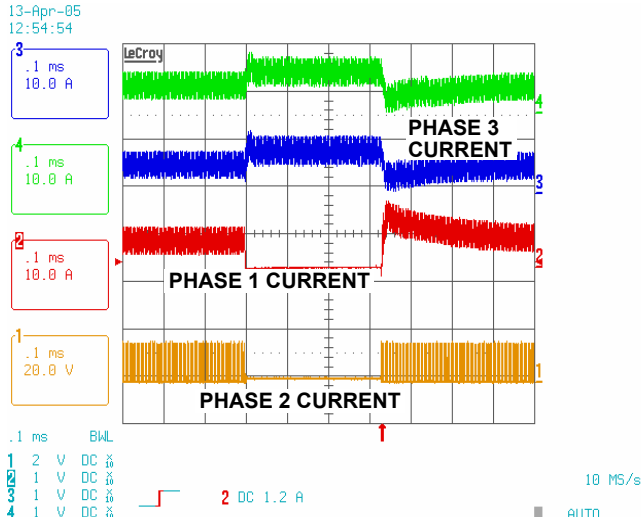

FIGURE 33. ISL9506, INDUCTOR CURRENT WAVEFORM WITH PHASE ADDING AND DROPPING IN CCM OR NOMINAL MODE

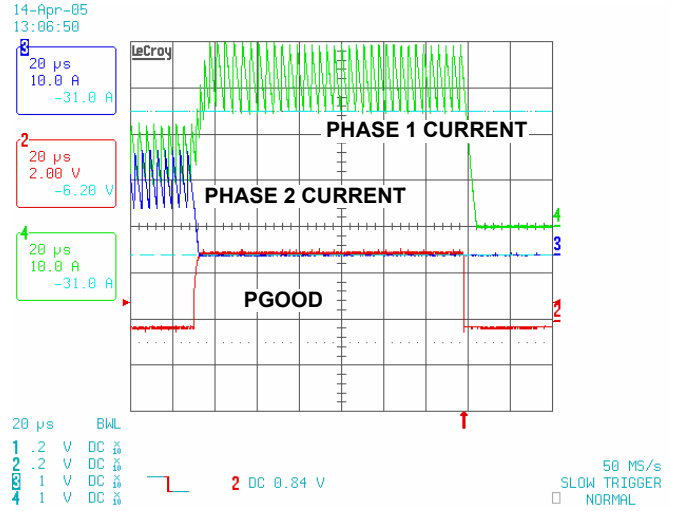

FIGURE 34. ISL9506, OVERCURRENT DUE TO PHASE DROPPING

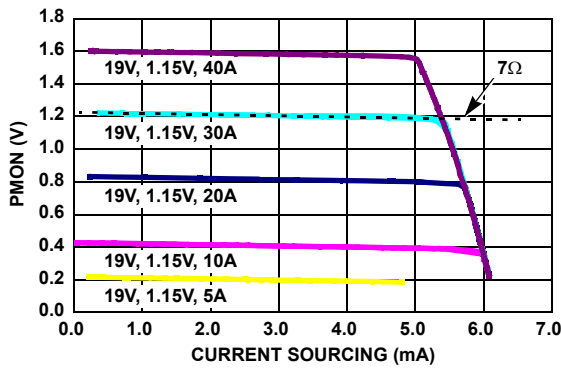

FIGURE 35. POWER MONITOR CURRENT SOURCING CAPABILITY

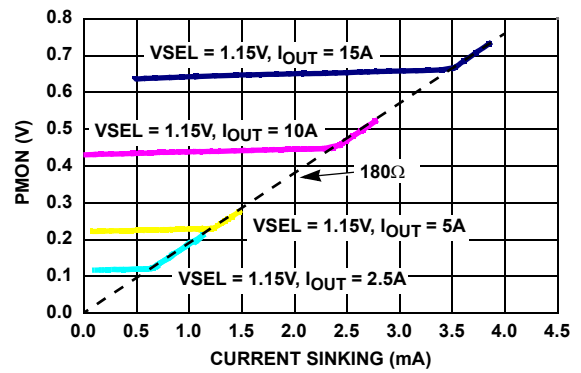

FIGURE 36. POWER MONITOR CURRENT SINKING CAPABILITY

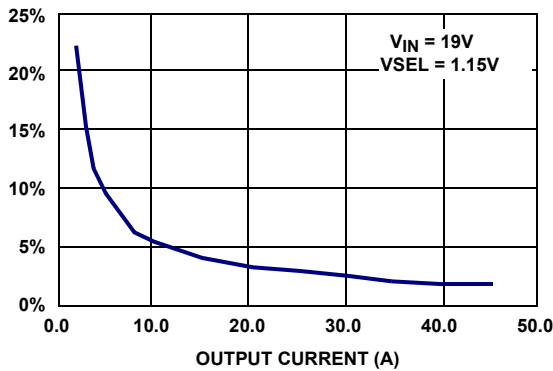

FIGURE 37. POWER MONITOR ACCURACY

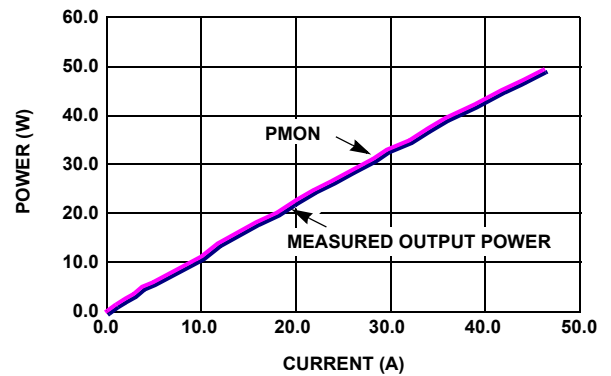

FIGURE 38. POWER MONITOR vs OUTPUT CURRENT

Simplified Application Circuit for DCR Current Sensing

Figure 39 shows a simplified application circuit for the ISL9506 converter with inductor DCR current sensing. The ISL6208 MOSFET gate driver has a force-continuous-conduction-mode (FCCM) input, that when disabled, allows the regulator to operate in Diode Emulation for improved light load efficiency. As shown in the circuit diagram, the FCCM pin is connected to ISL9506, which programs the CCM or DCM mode.

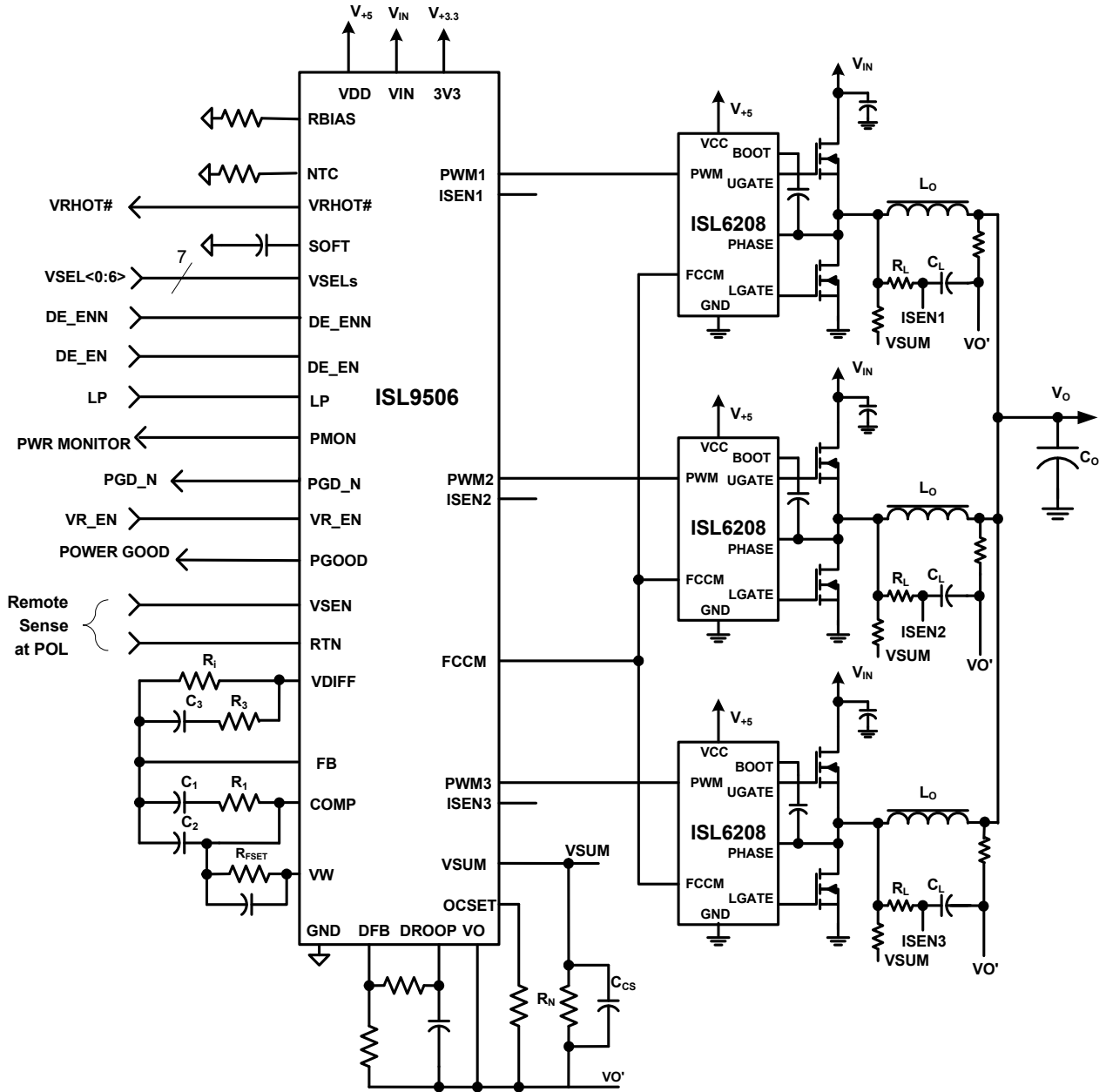

FIGURE 39. TYPICAL APPLICATION CIRCUIT FOR DCR SENSING

Simplified Application Circuit for Resistive Current Sensing

Figure 40 shows a simplified application circuit for the ISL9506 converter with external resistor current sensing. A capacitor is added in parallel with R_L in order to improve the stability margin of the channel current balance loop. No NTC thermistor is needed and the droop circuit is simplified.

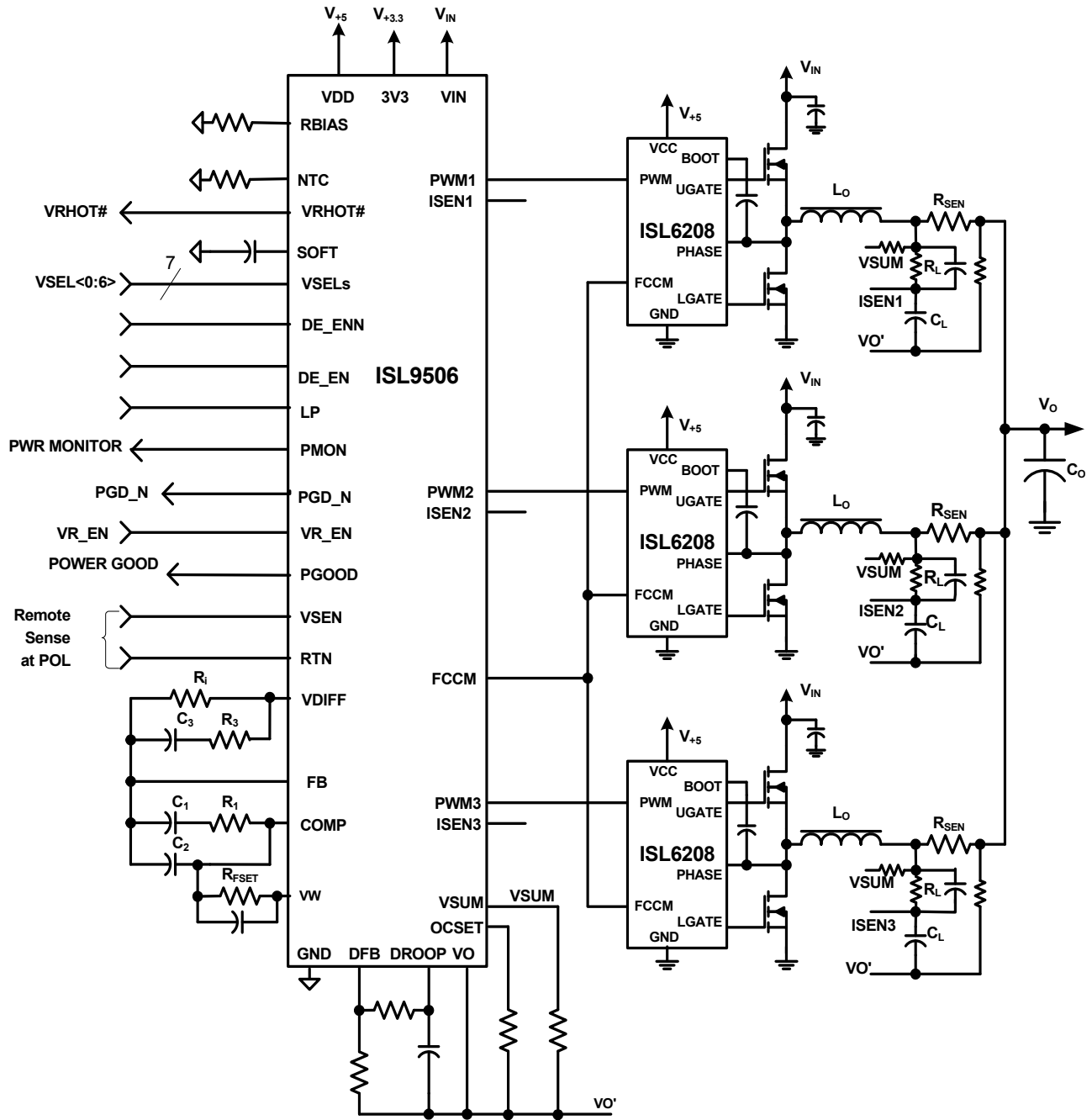

FIGURE 40. TYPICAL APPLICATION CIRCUIT FOR DISCRETE RESISTOR CURRENT SENSING

Functional Block Diagram

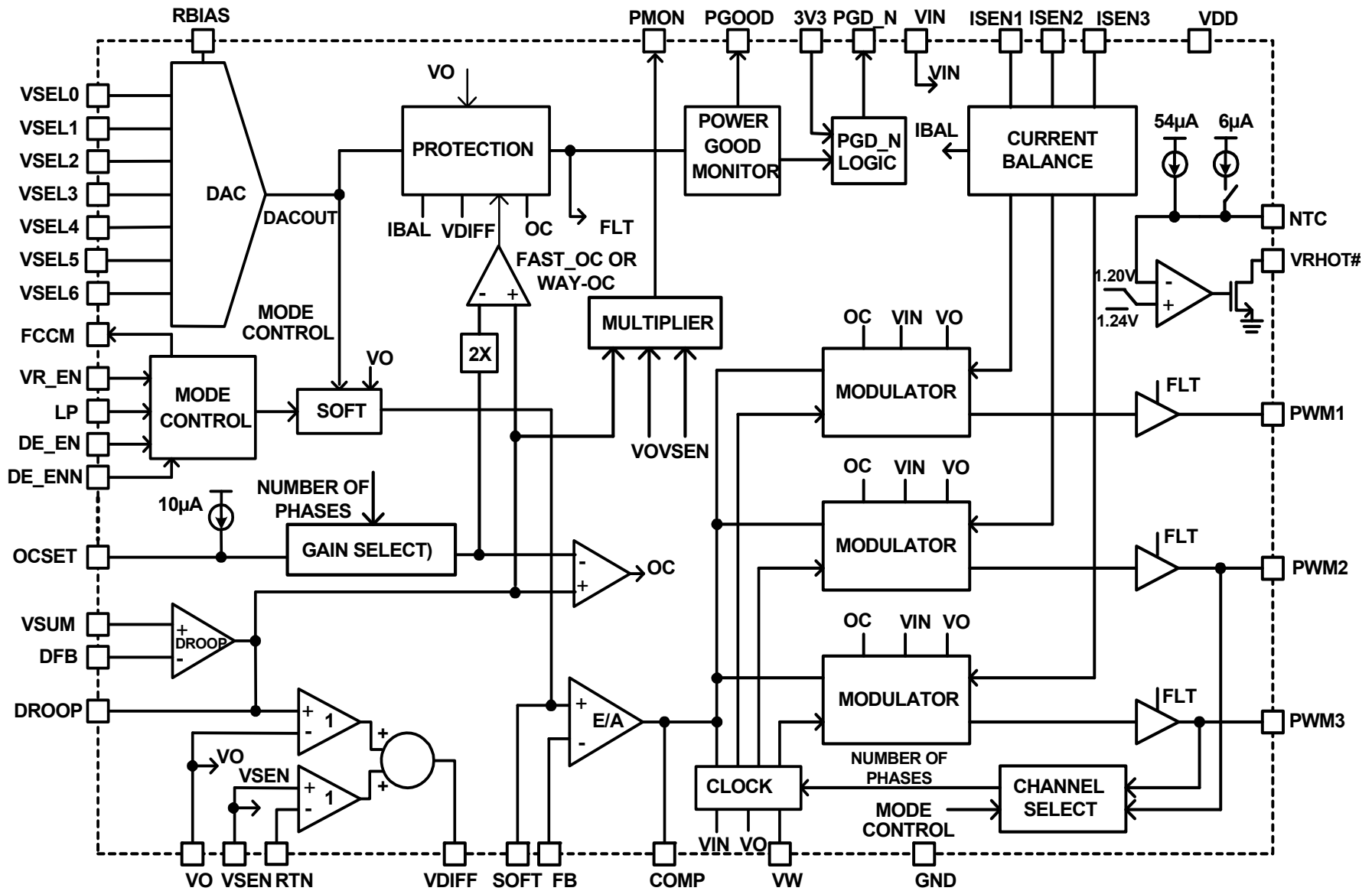

FIGURE 41. SIMPLIFIED BLOCK DIAGRAM

Theory of Operation

Operational Description

The ISL9506 is a multiphase regulator for digital processor core power application. It can be programmed for 1-, 2- or 3-channel operation. With ISL6208 gate driver capable of diode emulation, the ISL9506 provides optimum efficiency in both heavy and light load conditions.

ISL9506 uses Intersil patented R³ (Robust Ripple Regulator®) modulator. The R³® modulator combines the best features of fixed frequency PWM and hysteretic PWM while eliminating many of their shortcomings. The ISL9506 modulator internally synthesizes analog signals inside the IC emulating the inductor ripple currents and use hysteretic comparators on those signals to determine switching pulse widths. Operating on these large-amplitude, noise-free synthesized signals allows the ISL9506 to achieve lower output ripple and lower phase jitter than conventional hysteretic and fixed PWM mode controllers. Unlike conventional hysteretic converters, the ISL9506 has an error amplifier that allows the controller to maintain a 0.5% output voltage accuracy. At heavy load conditions, the ISL9506 is switching at a relatively constant switching frequency similar to fixed frequency PWM controller. At light load conditions, the ISL9506 is switching at a frequency proportional to load current similar to hysteretic mode controller.

The hysteresis window voltage rides on the error amplifier output such that a load current transient results in an increase in switching frequency to give the R³ regulator a faster response than conventional fixed frequency PWM controllers. The sharing of the hysteretic window voltage also inherently shares the transient load current between the phases. The individual average phase voltages are monitored and controlled to equally share the static current among the phases.

The ISL9506 disables PWM2 when LP is asserted low, and the power monitor pin provides an analog signal representing the output power of the converter.

Start-up Timing

With the controller's +5V V_{DD} voltage above the POR threshold, the start-up sequence begins when VR_EN exceeds the 3.3V logic HIGH threshold. Approximately 120μs later SOFT and V_{OUT} start ramping up to the start voltage of 1.2V. During this interval, the SOFT capacitor is charged with approximately 40μA. Therefore, if the SOFT capacitor is selected to be 20nF, the SOFT ramp will be at about 2mV/μs for a soft-start time of 600μs. Once V_{OUT} is within 10% of the start voltage for 13 PWM cycles (43μs for frequency = 300kHz), then PGD_N is pulled LOW and the SOFT capacitor is charged up with approximately 200μA. Therefore, V_{OUT} slews at +10mV/μs to the voltage set by the VSEL pins. Approximately 7ms later, PGOOD is asserted HIGH. A typical start-up timing is shown in Figure 42. Similar results occur if VR_EN is tied to V_{DD}, with

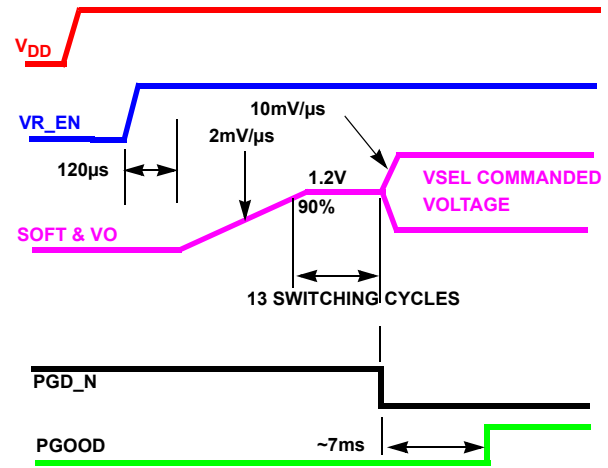

FIGURE 42. SOFT-START WAVEFORMS USING A 20nF SOFT CAPACITOR

the soft-start sequence starting 120μs after V_{DD} crosses the POR threshold.

Static Operation

VOLTAGE REGULATION AT ZERO LOAD CURRENT

After the start sequence, the output voltage will be regulated to the value set by the VSEL inputs per Table 1. The ISL9506 will control the no-load output voltage to an accuracy of ±0.5% over the range of 0.75V to 1.5V.

TABLE 1. VOLTAGE SELECTION TABLE

VSEL5	VSEL4	VSEL3	VSEL2	VSEL1	VSEL0	VSEL6=0	VSEL6=1
0	0	0	0	0	0	1.5000	0.7000
0	0	0	0	0	1	1.4875	0.6875
0	0	0	0	1	0	1.4750	0.6750
0	0	0	0	1	1	1.4625	0.6625
0	0	0	1	0	0	1.4500	0.6500
0	0	0	1	0	1	1.4375	0.6375
0	0	0	1	1	0	1.4250	0.6250
0	0	0	1	1	1	1.4125	0.6125
0	0	1	0	0	0	1.4000	0.6000
0	0	1	0	0	1	1.3875	0.5875
0	0	1	0	1	0	1.3750	0.5750
0	0	1	0	1	1	1.3625	0.5625
0	0	1	1	0	0	1.3500	0.5500
0	0	1	1	0	1	1.3375	0.5375
0	0	1	1	1	0	1.3250	0.5250
0	0	1	1	1	1	1.3125	0.5125
0	1	0	0	0	0	1.3000	0.5000
0	1	0	0	0	1	1.2875	0.4875
0	1	0	0	1	0	1.2750	0.4750

TABLE 1. VOLTAGE SELECTION TABLE (Continued)

VSEL5	VSEL4	VSEL3	VSEL2	VSEL1	VSEL0	VSEL6=0	VSEL6=1
0	1	0	0	1	1	1.2625	0.4625
0	1	0	1	0	0	1.2500	0.4500
0	1	0	1	0	1	1.2375	0.4375
0	1	0	1	1	0	1.2250	0.4250
0	1	0	1	1	1	1.2125	0.4125
0	1	1	0	0	0	1.2000	0.4000
0	1	1	0	0	1	1.1875	0.3875
0	1	1	0	1	0	1.1750	0.3750
0	1	1	0	1	1	1.1625	0.3625
0	1	1	1	0	0	1.1500	0.3500
0	1	1	1	0	1	1.1375	0.3375
0	1	1	1	1	0	1.1250	0.3250
0	1	1	1	1	1	1.1125	0.3125
1	0	0	0	0	0	1.1000	0.3000
1	0	0	0	0	1	1.0875	OFF
1	0	0	0	1	0	1.0750	OFF
1	0	0	0	1	1	1.0625	OFF
1	0	0	1	0	0	1.0500	OFF
1	0	0	1	0	1	1.0375	OFF
1	0	0	1	1	0	1.0250	OFF
1	0	0	1	1	1	1.0125	OFF
1	0	1	0	0	0	1.0000	OFF
1	0	1	0	0	1	0.9875	OFF
1	0	1	0	1	0	0.9750	OFF
1	0	1	0	1	1	0.9625	OFF
1	0	1	1	0	0	0.9500	OFF
1	0	1	1	0	1	0.9375	OFF
1	0	1	1	1	0	0.9250	OFF
1	0	1	1	1	1	0.9125	OFF
1	1	0	0	0	0	0.9000	OFF
1	1	0	0	0	1	0.8875	OFF
1	1	0	0	1	0	0.8750	OFF
1	1	0	0	1	1	0.8625	OFF
1	1	0	1	0	0	0.8500	OFF
1	1	0	1	0	1	0.8375	OFF
1	1	0	1	1	0	0.8250	OFF
1	1	0	1	1	1	0.8125	OFF
1	1	1	0	0	0	0.8000	OFF
1	1	1	0	0	1	0.7875	OFF
1	1	1	0	1	0	0.7750	OFF

TABLE 1. VOLTAGE SELECTION TABLE (Continued)

VSEL5	VSEL4	VSEL3	VSEL2	VSEL1	VSEL0	VSEL6=0	VSEL6=1
1	1	1	0	1	1	0.7625	OFF
1	1	1	1	0	0	0.7500	OFF
1	1	1	1	0	1	0.7375	OFF
1	1	1	1	1	0	0.7250	OFF
1	1	1	1	1	1	0.7125	OFF

A differential amplifier allows voltage sensing for precise voltage regulation at the point of load. The inputs to the amplifier are the VSEN and RTN pins.

DROOP IMPEDANCE OR DROOP ACCOMPLISHMENT

As the load current increases from zero, the output voltage will drop from the VSEL table value by an amount proportional to load current to achieve certain droop characteristics or droop impedance. The ISL9506 provides for current to be sensed using resistors in series with the channel inductors as shown in the application circuit of Figure 40 or using the intrinsic series resistance of the inductors as shown in the application circuit of Figure 39. In both cases, signals representing the inductor currents are summed at VSUM which is the non-inverting input to the DROOP amplifier shown in the block diagram of Figure 41. The voltage at the DROOP pin minus the output voltage at VO pin is the total load current multiplied by a gain factor. This value is used as an input to the differential amplifier to achieve the desired droop impedance as well as the input of the overcurrent circuit.

When using inductor DCR current sensing, a single NTC element is used to compensate the positive temperature coefficient of the copper winding thus sustaining the load-line accuracy with reduced cost.

PHASE CURRENT BALANCE

In addition to the total current which is used for DROOP and OCP, the individual channel average currents are also monitored by the phase node voltage. Channel current differences are sensed by comparing ISEN1, ISEN2, and ISEN3 voltage. The IBAL circuit will adjust the channel pulse-widths up or down relative to the other channels to cause the voltages presented to the ISEN pins to be equal.

ENABLE AND DISABLE PHASES

The ISL9506 controller can be configured for three-, two- or single-channel operation. To disable Channel 2 and/or Channel 3, its PWM output pin should be tied to +5V and the ISEN pins should be grounded. In three-channel operation, the three-channel PWM's are phase shifted by 120°, and in two-channel operation they are phase shifted by 180°.

SWITCHING FREQUENCY IN CCM/DCM MODE

The switching frequency is adjusted by the resistor between the error amplifier output and the VW pin. When ISL9506 is in continuous conduction mode (CCM), the switching frequency may not be as constant as that of a fixed frequency PWM controllers. However, the switching frequency variation will be kept small to maintain the output voltage ripple within specification. In general, the switching frequency will be very close to the set value at high input voltage and heavy load conditions.

When DE_EN is high and DE_ENN is low, the FCCM pin will become low, and discontinuous conduction mode (DCM) operation will be allowed in the ISL6208 gate drive. In DCM, ISL6208 turns off the lower FET after its channel current across zero. As load is further reduced, channel switching frequency will drop, providing optimized efficiency at light load. FCCM logic low is the signal to enable, or to allow the DCM operation. Only if the inductor current is really cross zero, does the true DCM occur.

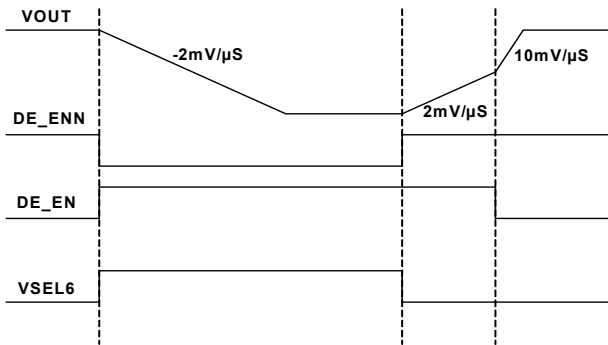

FIGURE 43. DIODE EMULATION TRANSITION SHOWING DE_EN's EFFECT ON EXIT SLEW RATE

Dynamic Operation

Refer to Figure 43. The ISL9506 responds to changes in VSEL command voltage by slewing to new voltages with a dV/dt set by the SOFT capacitor and by the state of DE_EN. With C_{SOFT} = 20nF and DE_EN is HIGH, the output voltage will move at ±2mV/μs for large changes in voltage. For DE_EN LOW, the large signal dV/dt will be ±10mV/μs. As the output approaches the VSEL command voltage, the dV/dt rate moderates to prevent overshoot. During Geyserville III transitions where there is one LSB VSEL step each 5μs, the controller will follow the VSEL command with its dV/dt rate of ±2.5mV/μs.

Keeping DE_EN HIGH during VSEL transitions will result in reduced dV/dt slew rate and lesser audio noise. For fastest recovery from Diode Emulation to Nominal mode, DE_EN LOW achieves higher dV/dt.

Intersil's R³ intrinsically has voltage-feed-forward. The output voltage is insensitive to a fast slew input voltage change. Refer to Figure 15 in the "Typical Operating Performance" on page 8" section of this document for Input Transient Performance.

The hysteresis window voltage is constructed with a resistor on the VW pin to the error amplifier outputs. The synthesized inductor current ripple signal compares with the window voltage and generates PWM signal. At load current step-up, the switching frequency is increased resulting in a faster response than conventional fixed frequency PWM controllers. As all the phases shares the same hysteretic window voltage, it also ensures excellent dynamic current balance between phases. The individual average phase voltages are monitored and controlled to achieve steady state current balance among the phases with current balance loop.

Modes of Operation Programmed by Logic Signals

The operational modes of ISL9506 are programmed by the control signals of DE_EN, DE_ENN, and LP. ISL9506 responds LP signal by adding or dropping PWM2 and adjusting the overcurrent protection level accordingly. For example, if the ISL9506 is initially used as 3-phase controller, the LP signal will add or drop PWM2 and leave PWM1 and PWM3 always in operation. Meanwhile, after PWM2 is dropped, the phase shift between the PWM1 and PWM3 is adjusted from 120° to 180° and the overcurrent and the way-overcurrent protection level will be adjusted to 2/3 of the initial value. If the ISL9506 is initially used as 2-phase operation, it is suggested that PWM1 and PWM2 pair, not PWM1 and PWM3 pair, should be used such that the LP signal will enable or disable PWM2 with PWM1 in operation always. The overcurrent and way-overcurrent protection level in two-to-one phase mode operation will be adjusted as two-to-one as well.

The DCM mode operation is independent of LP for ISL9506. It responds to the DE_EN and DE_ENN. Table 2 shows the operation modes of ISL9506 with combinations of control logic.

When LP is de-asserted low, ISEN2 pin is connected to the ISEN pins of the operational phases internally to keep proper current balance and minimize the inductor current overshoot and undershoot when the disabled phase is enabled again.

TABLE 2. ISL9506 MODE OF OPERATIONS

DE_EN	DE_ENN	LP	MODE OF OPERATION	MODE
0	1	1	N phase CCM	Nominal
0	1	0	N-1 phase CCM	Low Power
1	0	1	N phase DCM	Diode Emulation
1	0	0	N-1 phase DCM	Diode Emulation
0	0	1	N phase CCM	
0	0	0	N-1 phase CCM	
1	1	1	N phase CCM	
1	1	0	N-1phase CCM	

TABLE 3. THE FAULT PROTECTION AND RESET OPERATION OF ISL9506

	FAULT DURATION PRIOR TO PROTECTION	PROTECTION ACTIONS	FAULT RESET
Overcurrent	120µs	PWMs tri-state, PGOOD latched low	VR_EN toggle or VDD toggle
Way-Overcurrent (2.5 X OC)	<2µs	PWMs tri-state, PGOOD latched low	VR_EN toggle or VDD toggle
Overvoltage 1.7V	Immediately	Low side MOSFET on until Vcore <0.85V, then PWM tri-state, PGOOD latched low.	VDD toggle
Overvoltage +200mV	1ms	PWMs tri-state, PGOOD latched low	VR_EN toggle or VDD toggle
Undervoltage -300mV	1ms	PWMs tri-state, PGOOD latched low	VR_EN toggle or VDD toggle
Phase-Current Unbalance	1ms	PWMs tri-state, PGOOD latched low	VR_EN toggle or VDD toggle
Over-Temperature	Immediately	VRHOT# goes low	N/A

Protection

The ISL9506 provides overcurrent, overvoltage, and undervoltage protection. Overcurrent protection is related to the voltage droop which is determined by the droop impedance requirement. After the load-line is set, the OCSET resistor can be selected to detect overcurrent at any level of droop voltage. For overcurrent less than 2.5x the OCSET level, the overload condition must exist for 120µs in order to trip the OC fault latch. This is shown in Figure 28.

For overload exceeding 2.5x the OCSET level, the PWM outputs will immediately shut off and PGOOD will go low to maximize protection due to hard short circuit. This protection was referred to as way-overcurrent or fast over current, for short-circuit protections.

In addition, excessive phase unbalance due to gate driver failure will be detected and will shut down the controller. The phase unbalance is detected by the voltage on the ISEN pin. If the ISEN pin voltage difference is greater than 9mV for 1ms, the controller will latch off.

Undervoltage protection is independent of the overcurrent limit. If the output voltage is less than the VSEL set value by 300mV or more, a fault will latch after 1ms in that condition. The PWM outputs will turn off and PGOOD will go low. This is shown in Figure 27. Note that most practical core voltage regulators will have the overcurrent set to trip before the -300mV undervoltage limit.

There are two levels of overvoltage protection with different responses. The first level of overvoltage protection is referred to as PGOOD overvoltage protection. Basically, for output voltage exceeding the set value by +200mV for 1ms, a fault will be declared with PGOOD latched low.

All of the above faults have the same action taken: PGOOD is latched low and the upper and lower power FETs are turned off so that inductor current will decay through the FET body diodes. This condition can be reset by bringing VR_EN low or by bringing V_{DD} below POR threshold. When

these inputs are returned to their high operating levels, a soft-start will occur.

The second level of overvoltage protection behaves differently. If the output exceeds 1.7V, an OV fault is immediately declared, PGOOD is latched low and the low-side FETs are turned on. The low-side FETs will remain on until the output voltage is pulled down below 0.85V at which time all FETs are turned off. If the output again rises above 1.7V, the process is repeated. This affords the maximum amount of protection against a shorted high-side FET while preventing output ringing below ground. The 1.7V OVP cannot be reset with VR_EN, but requires that V_{DD} be lowered to reset. The 1.7V OV detector is nominal at all times when the controller is enabled including after one of the other faults occurs. This ensures the load is protected against high-side FET leakage while the FETs are commanded off. The ISL9506 has a thermal throttling feature. If the voltage on the NTC pin goes below the 1.18V OT threshold, the VRHOT# pin is pulled low indicating the need for thermal throttling to the system oversight load. No other action is taken within the ISL9506 in response to NTC pin voltage.

Fault protection is summarized in Table 3.

Power Monitor

The power monitor signal is an analog output. Its magnitude is proportional to the product of V_{SEN} and the voltage difference between V_{DROOP} and V_O, which is the programmed droop impedance multiplied by load current. The output voltage of the PMON pin is given by:

$$V_{PMON} = V_{SEN} * (V_{DROOP} - V_O) * 17.5 \text{ (Volt)} \quad (\text{EQ. 1})$$

The power consumed by the load can be calculated by:

$$P_{LOAD} = V_{PMON} / (17.5 * 0.0021) \text{ (Watt)} \quad (\text{EQ. 2})$$

where the 0.0021 is the droop impedance. The power monitor load regulation is about 7Ω. Basically, within its

sourcing/sinking current capability range, when the power monitor loading changes 1mA, the output of the power monitor will change 7mV. The 7Ω impedance is associated with the layout and packaging resistance of PMON pin inside the IC. Compared to the load resistance on the power monitor pin in practical applications, 7Ω output impedance contributes no significance of error.

Component Selection and Application

Soft-Start and Mode Change Slew Rates

The ISL9506 uses 2 slew rates for various modes of operation. The first is a slow slew rate, used to reduce inrush current on start-up. It is also used to reduce audible noise when entering or exiting Diode Emulation Mode. A faster slew rate is used to exit out of Diode Emulation and to increase system performance by achieving nominal mode regulation more quickly. Note that the SOFT capacitor current is bidirectional and is flowing into the SOFT capacitor when the output voltage is commanded to rise, and out of the SOFT capacitor when the output voltage is commanded to fall.

The two slew rates are determined by the currents into the SOFT pin. As can be seen in Figure 44, the SOFT pin has a capacitance to ground. Also, the SOFT pin is the input to the error amplifier and is, therefore, the commanded system voltage. Depending on the state of the system, i.e. Start-Up or Nominal mode, and the state of the DE_EN pin, one of the two currents shown in Figure 44 will be used to charge or discharge this capacitor, thereby controlling the slew rate of the commanded voltage. These currents can be found under the Soft Current section of the Electrical Specifications Table on page 4.

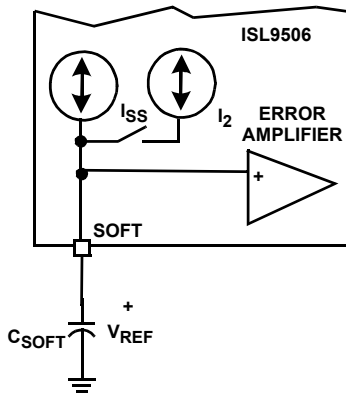

FIGURE 44. SOFT PIN CURRENT SOURCES FOR FAST AND SLOW SLEW RATES

The first current, labeled I_{SS} , is given in the specification table as 42μA. This current is used during Soft-Start. The second current, I_2 sums with I_{SS} to get the large current labeled I_{GV} in the Electrical Specifications Table on page 4. This total current is typically 205μA with a minimum of 180μA.

The desired V_{OUT} slew rate will determine the choice of the SOFT capacitor, C_{SOFT} , by Equation 3:

$$C_{SOFT} = \frac{I_{GV}}{SLEWRATE} \quad (\text{EQ. 3})$$

Using a SLEWRATE of 10mV/μs, and the typical I_{GV} value, given in the Electrical Specification Table of 205μA, C_{SOFT} is calculated by using Equation 4:

$$C_{SOFT} = \frac{205\mu A}{\frac{10\text{mV}}{1\mu s}} = 0.0205\mu F \quad (\text{EQ. 4})$$

A choice of 0.015μF would guarantee a SLEWRATE of 10mV/μs is met for minimum I_{GV} value, given in the Electrical Specifications Table on page 4

Now this choice of C_{SOFT} will then control the start-up slewrate as well. One should expect the output voltage to slew to the start value of 1.2V at a rate given by Equation 5:

$$\frac{dV}{dt} = \frac{I_{SS}}{C_{SOFT}} = \frac{42\mu A}{0.015\mu F} = 2.8\frac{\text{mV}}{\mu s} \quad (\text{EQ. 5})$$

Generally, when output voltage is approaching its steady state, its dv/dt will slow down to prevent overshoot. In order to compensate the slow-down effect, faster initial dv/dt slew rates can be used with small soft capacitors such as 10nF to achieve the desired overall dv/dt in the allocated time interval.

Selecting R_{BIAS}

To properly bias the ISL9506, a reference current is established by placing a 147kΩ, 1% tolerance resistor from the R_{BIAS} pin to ground. This will provide a highly accurate, 10μA current source from which OCSET reference current can be derived.

Care should be taken in layout that the resistor is placed very close to the R_{BIAS} pin and that a good quality signal ground is connected to the opposite side of the R_{BIAS} resistor. Do not connect any other components to this pin. Capacitance on this pin would create instabilities and should be avoided.

Start-up Operation - PGD_N and PGOOD

The ISL9506 provides a 3.3V logic output pin for PGD_N. The 3V3 pin allows for a system 3.3V source to be connected to separated circuitry inside the ISL9506, solely devoted to the PGD_N function. The output is a 3.3V CMOS signal with 4mA of source and sinking capability. This implementation removes the need for an external pull-up resistor on this pin, and due to the normal level of this signal being a low, removes the leakage path from the 3.3V supply to ground through the pull-up resistor. This reduces 3.3V supply current, that would occur under normal operation with a pull-up resistor, and prolongs battery life. The 3.3V supply should be decoupled to digital ground, not to analog ground for noise immunity.

As mentioned in the “Theory of Operation” on page 16 section of this data sheet, PGD_N is logic level high at start-up. When the output voltage reaches 90% of start voltage, a counter is enabled, it counts 13 switching cycles (about 43μs for 300kHz operation) then PGD_N goes low. This in turn triggers an internal timer for the PGOOD signal. This timer allows PGOOD to go high approximately 7ms after PGD_N goes low.

Static Mode of Operation - Remote Voltage Sensing

Remote Voltage sensing allows the Voltage Regulator to compensate for various resistive drops in the power path and insure that the voltage seen at the point of load is the correct level independent of load current.

The VSEN and RTN of the ISL9506 are the Kelvin connection pins to the point of load. This allows the Voltage Regulator to tightly control the output voltage at the point of load, independent of layout inconsistencies and drops. This Kelvin sense technique provides for extremely tight droop impedance regulation.

These traces should be laid out as noise sensitive traces. For optimum droop impedance regulation performance, the traces connecting these two pins to the Kelvin sense point of the load must be laid out in parallel and away from rapidly rising voltage nodes (switching nodes) and other noisy traces. To achieve optimum performance, place common mode and differential mode RC filters to analog ground on VSEN and RTN as shown in Figure 46. However, the filter resistors should be in order of 10Ω so that they do not interact with the 50kΩ input resistance of the differential amplifier.

Due to the fact that the voltage feedback to the switching regulator is sensed at the point of load, there exists the potential of an overvoltage due to an open circuit feedback signal, should the regulator be operated without the load installed. Due to this fact, we recommend the use of the R_{OPN1} and R_{OPN2} connected to V_{OUT} and ground as shown in Figure 46. These resistors will provide voltage feedback in the event that the system is powered up without the load installed. These resistors are typically 100Ω.

Setting the Switching Frequency - FSET

The R₃ modulator scheme is not a fixed frequency PWM architecture. The switching frequency can increase during the application of a load to improve transient performance. However, it also varies slightly due changes in input and output voltage and output current, but this variation is normally less than 10% in continuous conduction mode.

Refer to Figure 39. A resistor connected between the VW and COMP pins of the ISL9506 adjusts the switching window, and therefore adjusts the switching frequency. The R_{FSET} resistor that sets the switching frequency of the converter operating in CCM can be determined using the

following relationship, where R_{FSET} is in kΩ and the switching period is in μs.

$$R_{fset}(k\Omega) = (\text{Period}(\mu\text{s}) - 0.29) \times 2.33 \quad (\text{EQ. 6})$$

In discontinuous conduction mode, (DCM), the ISL9506 runs in period stretching mode. It should be noted that the switching frequency in the Electrical Specification Table is tested with the error amplifier output or Comp pin voltage at 2V. When Comp pin voltage is lower, the switching frequency will not be at the tested value but can still maintain the output voltage ripple within specification.

Voltage Regulator Thermal Throttling

The ISL9506 features a thermal monitor which senses the voltage change across an externally placed negative temperature coefficient (NTC) thermistor, see Figure 45. Proper selection and placement of the NTC thermistor allows for detection of a designated temperature rise by the system.

Figure 45 shows the thermal throttling feature with hysteresis. At low temperature, SW1 is on and SW2 connects to the 1.20V side. The total current going from NTC pin is 60μA. The voltage on NTC pin is higher than threshold voltage of 1.20V and the comparator output is low. VRHOT# is pulling up high by the external resistor.

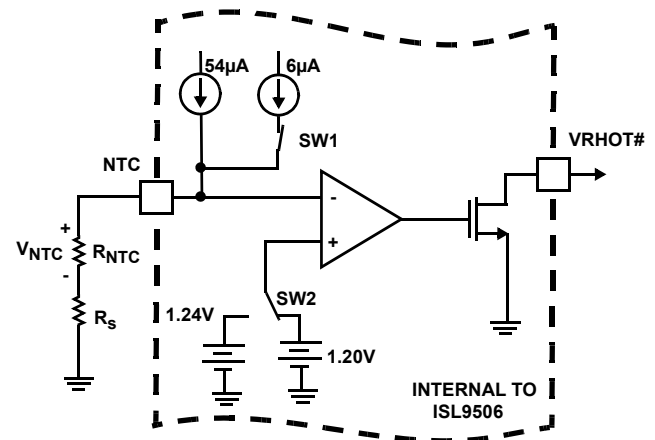

FIGURE 45. CIRCUITRY ASSOCIATED WITH THE THERMAL THROTTLING FEATURE OF THE ISL9506

When temperature increases, the NTC thermistor resistance on NTC pin decreases. The voltage on NTC pin decreases to a level lower than 1.20V. The comparator changes polarity and turns SW1 off and throws SW2 to 1.24V. This pulls VRHOT# low and sends the signal to start thermal throttle. There is a 6μA current reduction on NTC pin and 40mV voltage increase on threshold voltage of the comparator in this state. The VRHOT# signal will be used to change the load operation and decrease the power consumption. When the temperature goes down, the NTC thermistor voltage will eventually go up. If NTC voltage increases to 1.24V, the comparator will then be able to flip back. The external

resistance difference in these two conditions as shown in Equation 7:

$$\frac{1.24V}{54\mu A} - \frac{1.20V}{60\mu A} = 2.96k \quad (\text{EQ. 7})$$

Therefore, proper NTC thermistor has to be chosen such that 2.96k resistor change will be corresponding to required temperature hysteresis. Regular external resistor may need to be in series with NTC resistors to meet the threshold voltage values.

The following is an example.

For Panasonic NTC thermistor with B = 4700, its resistance will drop to 0.03322 of its nominal at 105°C, and drop to 0.03956 of its nominal at 100 °C. If the requirement for the temperature hysteresis is (105-100) °C, the required resistance of NTC will be:

$$\frac{2.96k\Omega}{(0.03956 - 0.03322)} = 467k\Omega \quad (\text{EQ. 8})$$

Therefore a larger value thermistor, such as 470k NTC should be used.

At 105°C, 470k NTC resistance becomes: (0.03322*470k) = 15.6k. With 60µA on NTC pin, the voltage is only (15.6k*60µA) = 0.937V. This value is much lower than the threshold voltage of 1.20V. Therefore, a resistor is needed to be in series with the NTC. The required resistance can be calculated by using Equation 9:

$$\frac{1.20V}{60\mu A} - 15.6k\Omega = 4.4k\Omega \quad (\text{EQ. 9})$$

4.42k is a standard resistor value. Therefore, the NTC branch should have a 470k NTC and 4.42k resistor in series. The part number for the NTC thermistor is ERTJ0EV474J. It is a 0402 package. NTC thermistor will be placed in the hot spot of the board.

Static Mode of Operation - Static Droop using DCR Sensing

As previously mentioned, the ISL9506 has an internal differential amplifier which provides for extremely accurate voltage regulation at the point of load. The droop impedance regulation is also very accurate, and the process of selecting the components for the appropriate droop impedance is explained here.

For DCR sensing, the process of compensation for DCR resistance variation to achieve the desired droop impedance has several steps and is somewhat iterative.

In Figure 46 we show a 3 phase solution using DCR sensing. There are two resistors around the inductor of each phase. These are labeled RS and RO. These resistors are used to sense the DC voltage drop across each inductor. Each inductor will have a certain level of DC current flowing through it, this current when multiplied by the DCR of the

inductor creates a small DC level of voltage. When this voltage is summed with the other channels DC voltages, the total DC load current can be derived.

RO is typically 5 to 10Ω. This resistor is used to tie the outputs of all channels together and thus create a summed average of the local CORE voltage output. RS is determined through an understanding of both the DC and transient load currents. This value will be covered in the next section.

However, it is important to keep in mind that the output of each of these RS resistors are tied together to create the VSUM voltage node. With both the outputs of RO and RS tied together, the simplified model for the droop circuit can be derived. This is presented in Figure 47.

Figure 47 shows the simplified model of the droop circuitry. Essentially one resistor can replace the RO resistors of each phase and one RS resistor can replace the RS resistors of each phase. The total DCR drop due to load current can be replaced by a DC source, the value of which is given by Equation 10.

$$V_{dcr_{EQV}} = \frac{I_{OUT} \times DCR}{N} \quad (\text{EQ. 10})$$

where N is the number of channels designed for nominal operation. Another simplification was done by reducing the NTC network comprised of R_{NTC}, R_{SERIES} and R_{PARALLEL}, given in Figure 46, to a single resistor given as R_n as shown in Figure 47.

The first step in droop impedance compensation is to adjust R_n, R_{O_{EQV}} and R_{S_{EQV}} such that sufficient droop voltage exists even at light loads between the VSUM and VO' nodes. We recognize that these components form a voltage divider. As a rule of thumb we start with the voltage drop across the R_n network, V_N, to be 0.57 x V_{DCR}. This ratio provides for a fairly reasonable amount of light load signal from which to arrive at droop.

First we calculate the equivalent NTC network resistance, R_n. Typical values that provide good performance are, R_{series} = 3.57k_1%, R_{PAR} = 4.53k_1% and R_{NTC} = 10kΩ NTC, ERT-J1VR103J from Panasonic. R_n is then given by Equation 11.

$$R_n = \frac{(R_{series} + R_{ntc}) \times R_{par}}{R_{series} + R_{ntc} + R_{par}} = 3.4k\Omega \quad (\text{EQ. 11})$$

In our second step, we calculate the series resistance from each phase to the V_{SUM} node, labeled RS1, RS2 and RS3 in Figure 46.

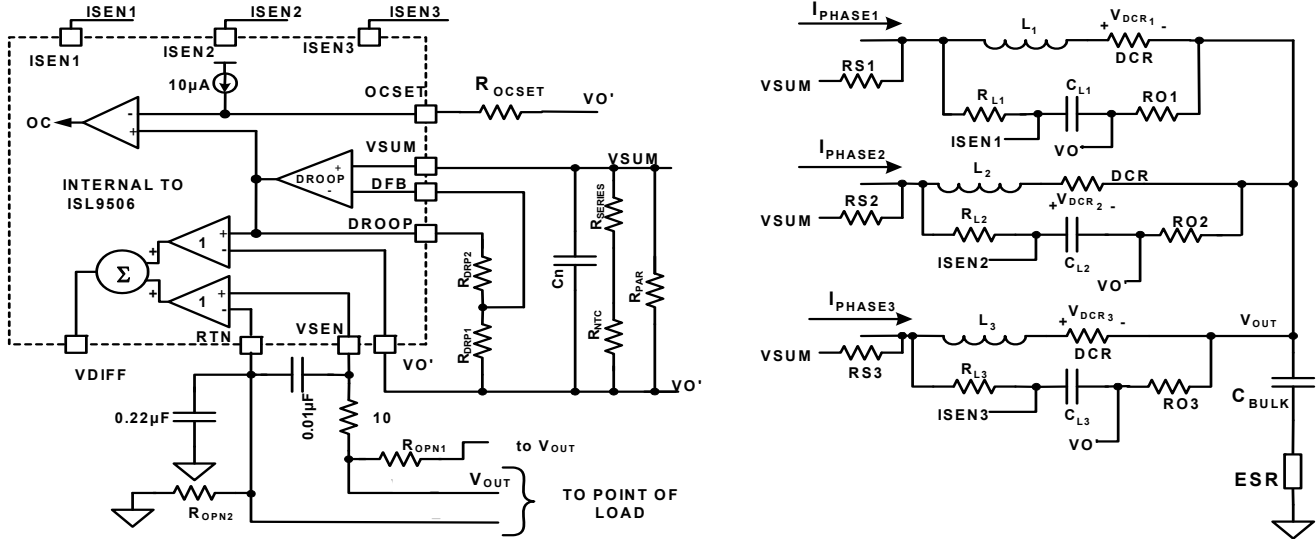

FIGURE 46. EQUIVALENT MODEL FOR DROOP AND REMOTE SENSING USING DCR SENSING

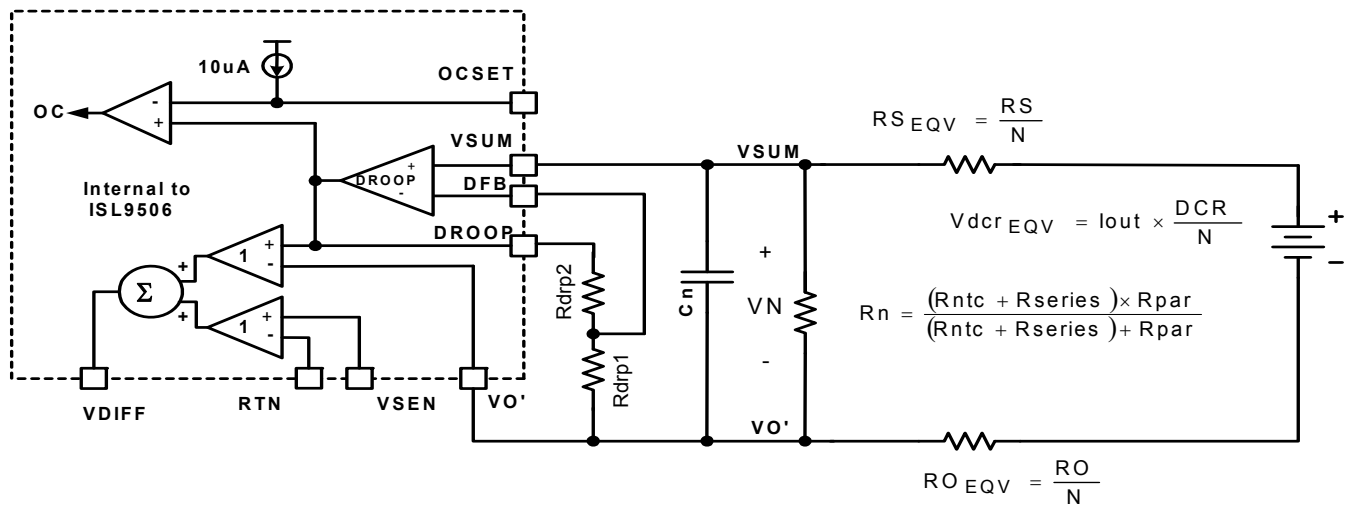

FIGURE 47. EQUIVALENT MODEL FOR DROOP AND REMOTE SENSING USING DCR SENSING

We do this using the assumption that we desire approximately a 0.57 gain from the DCR voltage, V_{DCR} , to the R_n network. We call this gain, G_1 .

$$G_1 = 0.57 \tag{EQ. 12}$$

After simplification, then RS_{EQV} is given by Equation 13:

$$RS_{EQV} = \left(\frac{1}{G_1} - 1\right) R_n = 2.56k\Omega \tag{EQ. 13}$$

The individual resistors from each phase to the VSUM node, labeled RS_1 , RS_2 and RS_3 in Figure 46, are then given by

Equation 14, where N is 3, for the number of channels in nominal operation.

$$RS = N \times RS_{EQV} = 7.69k\Omega \tag{EQ. 14}$$

Choosing $RS = 7.68k_{-1\%}$ is a good choice. Once we know the attenuation of the RS and RN network, we can then determine the Droop amplifier Gain required to achieve the droop impedance. Setting $R_{drp1} = 1k_{-1\%}$, then R_{drp2} is can be found using Equation 15.

$$R_{drp2} = \left(\frac{N \times R_{droop}}{DCR \times G_1} - 1\right) \times R_{drp1} \tag{EQ. 15}$$

Setting $N = 3$ for 3 channel operation, Droop Impedance (R_{droop}) = 0.0021 (V/A) as per the desired specification. DCR

= 0.0012Ω typical, Rdrp1 = 1kΩ and the attenuation gain (G1) = 0.57, Rdrp2 is then:

$$R_{drp2} = \left(\frac{3 \times 0.0021}{0.0012 \times 0.57} - 1 \right) \times 1K = 8.21k\Omega \quad (\text{EQ. 16})$$

Rdrp2 is selected to be a 8.25k_1% resistor. Note, we choose to ignore the RO resistors because they do not add significant error.

These values are extremely sensitive to layout and coupling factor of the NTC to the inductor. As only one NTC is required in this application, this NTC should be placed as close to the Channel 1 inductor as possible. And very importantly, the PCB traces sensing the inductor voltage should be go directly to the inductor pads.

Once the board has been laid out, some adjustments may be required to adjust the full load droop voltage. This can be accomplished by allowing the system to achieve thermal equilibrium at full load, and then adjusting Rdrp2 to obtain the appropriate droop impedance.

To see whether the NTC has compensated the temperature change of the DCR, the user can apply full load current and wait for the thermal steady state and see how much the output voltage will deviate from the initial voltage reading. A good NTC thermistor compensation can limit the output voltage drift to 2mV. If the output voltage is decreasing with temperature increase, that ratio between the NTC thermistor value and the rest of the resistor divider network has to be increased. Users should use the ISL9506 evaluation board component values and follow the evaluation board layout of NTC as much as possible to minimize engineering time.

The desired droop impedance should be adjusted by Rdrp2 based on maximum current steps, not based on small current steps. Basically, if the max current is 40A, the required droop voltage is 84mV with 2.1mΩ droop impedance. The user should have 40A load current on the converter and look for 84mV droop. If the droop voltage is less than 84mV, for example, 80mV. The new value will be calculated by Equation 17:

$$R_{drp2_new} = \frac{84 \text{ mV}}{80 \text{ mV}} (R_{drp1} + R_{drp2}) - R_{drp1} \quad (\text{EQ. 17})$$

For the best accuracy, the equivalent resistance on the DFB and VSUM pins should be identical so that the bias current of the droop amplifier does not cause an offset voltage. In the example above, the resistance on the DFB pin is Rdrp1 in parallel with Rdrop2, that is, 1k in parallel with 8.21k or 890Ω. The resistance on the VSUM pin is Rn in parallel with RSeqv or 3.4k in parallel with 2.56k or 1460Ω. The mismatch in the effective resistances is 1460 - 890 = 570Ω. To reduce the mismatch, multiply both Rdrp1 and Rdrp2 by the appropriate factor. The appropriate factor in the example is 1460/890 = 1.64.

Dynamic Mode of Operation - Dynamic Droop using DCR Sensing

Droop is very important for load transient performance. If the system is not compensated correctly, the output voltage could sag excessively upon load application and potentially create a system failure. The output voltage could also take a long period of time to settle to its final value.

The L/DCR time constant of the inductor must be matched to the Rn*Cn time constant as shown in Equation 18:

$$\frac{L}{DCR} = \left(\frac{R_n \times R_{S_{EQV}}}{R_n + R_{S_{EQV}}} \right) \times C_n \quad (\text{EQ. 18})$$

Solving for Cn we now have Equation 19:

$$C_n = \frac{\frac{L}{DCR}}{\left(\frac{R_n \times R_{S_{EQV}}}{R_n + R_{S_{EQV}}} \right)} \quad (\text{EQ. 19})$$

Note, RO was neglected. As long as the inductor time constant matches the droop circuit RC time constants as given above, the transient performance will be optimum. The selection of Cn may require a slight adjustment to correct for layout inconsistencies and component tolerance. For the example of L = 0.5μH, Cn is calculated in Equation 20:

$$C_n = \frac{\frac{0.5\mu\text{H}}{0.0012}}{\left(\frac{3.4k\Omega \times 2.56k\Omega}{3.4k\Omega + 2.56k\Omega} \right)} = 28.5\text{nF} \quad (\text{EQ. 20})$$

The value of this capacitor is selected to be 27nF. As the inductors tend to have 20% to 30% tolerances, this cap generally will be tuned on the board by examining the transient voltage. If the output voltage transient has an initial dip, lower than the voltage required by the droop impedance, and is slowly increasing back to the steady state, the capacitor should be increased and vice versa. It is better to have the capacitor value a little bigger to cover the tolerance of the inductor to prevent the output voltage from going lower than the spec. This capacitor needs to be a high grade capacitor like X7R with low tolerance. There is another consideration in order to achieve better time constant match mentioned above. The NPO/COG (class-I) capacitors have only 5% tolerance and a very good thermal characteristics. But those capacitors are only available in small capacitance values. In order to use such capacitors, the resistors and thermistors surrounding the droop voltage sensing and droop amplifier has to be resized up to 10x to reduce the capacitance by 10x. But attention has to be paid in balancing the impedance of droop amplifier in this case.

Dynamic Mode of Operation - Compensation Parameters

Considering the voltage regulator as a black box with a voltage source controlled by VSEL and a series impedance, in order to achieve certain droop impedance, the series impedance inside the black box needs to be this desired value. The compensation design has to ensure the output impedance of

the converter be lower than this desired value. There is a mathematical calculation file available to the user. The power stage parameters such as L and Cs are needed as the input to calculate the compensation component values. Attention has been paid to the input resistor to the FB pin. Too high of a resistor will cause an error to the output voltage regulation because of bias current flowing in the FB pin. It is better to keep this resistor below 3k when using this file.

Static Mode of Operation - Current Balance using DCR or Discrete Resistor Current Sensing

Current Balance is achieved in the ISL9506 through the matching of the voltages present on the ISEN pins. The ISL9506 adjusts the duty cycles of each phase to maintain equal potentials on the ISEN pins. RL and CL around each inductor, or around each discrete current resistor, are used to create a rather large time constant such that the ISEN voltages have minimal ripple voltage and represent the DC current flowing through each channel's inductor. For optimum performance, RL is chosen to be 10kΩ and CL is selected to be 0.22μF. When discrete resistor sensing is used, a capacitor of 10nF should be placed in parallel with RL to properly compensate the current balance circuit.

1. ISL9506 uses RC filter to sense the average voltage on phase node and forces the average voltage on the phase node to be equal for current balance. Even though the ISL9506 forces the ISEN voltages to be almost equal, the inductor currents will not be exactly the same. Take DCR current sensing as example, two errors have to be added to find the total current imbalance. 1) Mismatch of DCR: If the DCR has a 5% tolerance, then the resistors could mismatch by 10% worst case. If each phase is carrying 20A then the phase currents mismatch by $20A \times 10\% = 2A$. 2) Mismatch of phase voltages/offset voltage of ISEN pins. The phase voltages are within 2mV of each other by current balance circuit. The error current that results is given by $2mV/DCR$. If $DCR = 1m\Omega$ then the error is 2A.

In the above example, the two errors add to 4A. For a two phase DC/DC, the currents would be 22A in one phase and 18A in the other phase. In the above analysis, the current balance can be calculated with $2A/20A = 10\%$. This is the worst case calculation, for example, the actual tolerance of two 10% DCRs is $10\% \times \sqrt{2} = 7\%$.

There are provisions to correct the current imbalance due to layout or to purposely divert current to certain phase for better thermal management. Customer can put a resistor in parallel with the current sensing capacitor on the phase of interest in order to purposely increase the current in that phase. It is highly recommended to use symmetrical layout in order to achieve natural current balance.

In the case the PCB board trace resistance from the inductor to the point of load are not the same on all three phases, the current will not be balanced. On the phases that have too much trace resistance a resistor can be added in parallel with the ISEN capacitor that will correct for the poor layout.

An estimate of the value of the resistor is:

$$R_{tweak} = R_{isen} * [2 * R_{dcr} - (R_{trace} - R_{min})] / [2 * (R_{trace} - R_{min})] \quad (EQ. 21)$$

where R_{isen} is the resistance from the phase node to the ISEN pin; usually 10kΩ. R_{dcr} is the DCR resistance of the inductor. R_{trace} is the trace resistance from the inductor to the point of load on the phase that needs to be tweaked. It should be measured with a good microΩ meter. R_{MIN} is the trace resistance from the inductor to the load on the phase with the least resistance.

For example, if the PC board trace on one phase is 0.5mΩ and on another trace is 0.3mΩ; and if the DCR is 1.2mΩ; then the tweaking resistor is

$$R_{tweak} = 10k\Omega * [2 * 1.2 - (0.5 - 0.3)] / [2 * (0.5 - 0.3)] = 55k\Omega \quad (EQ. 22)$$

For extremely unsymmetrical layout causing phase current unbalance, ISL9506 applications schematics can be modified to correct the problem.

Droop using Discrete Resistor Sensing - Static/ Dynamic Mode of Operation

When choosing current sense resistor, not only the tolerance of the resistance is important, but also the TCR. Thus, its combined tolerance at a wide temperature range should be calculated.

Figure 48 shows the equivalent circuit of a discrete current sense approach. Figure 40 shows the simplified schematic of this approach.

For discrete resistor current sensing circuit, the droop circuit parameters can be solved the same way as the DCR sensing approach with a few slight modifications.

First, there is no NTC required for thermal compensation, therefore, the R_n resistor network in the previous section is not required. Secondly, there is no time constant matching required, therefore, the C_n component is not needed to match the L/DCR time constant, but this component does indeed provide noise immunity, especially to noise voltage caused by the ESL of the current sensing resistors. A 47pF capacitor can be used for such purposes.

The R_s values in the previous section, $R_s = 7.68k_{\pm 1\%}$ are sufficient for this approach.

Now, the input to the Droop amplifier is the V_{RSENSE} voltage. This voltage is given by Equation 23:

$$V_{rsense} = \frac{R_{sense}}{N} \times I_{OUT} \quad (EQ. 23)$$

The gain of the Droop amplifier, G_2 , must be adjusted equal to the droop impedance. See Equation 24:

$$G_2 = \frac{R_{droop}}{R_{sense}} \times N \quad (EQ. 24)$$

Assuming $N = 3$, $R_{droop} = 0.0021(V/A)$ as per the desired specification, $R_{sense} = 0.001\Omega$, we obtain $G_2 = 6.3$.

The values of Rdrp1 and Rdrp2 are selected to satisfy two requirements. First, the ratio of Rdrp2 and Rdrp1 determine the gain $G2 = (Rdrp2/Rdrp1)+1$. Second, the parallel combination of Rdrp1 and Rdrp2 should equal the parallel combination of the Rs resistors. Combining these requirements gives:

$$Rdrp1 = G2/(G2-1) * Rs/N$$

$$Rdrp2 = (G2-1) * Rdrp1$$

In the example above, Rs = 7.68k, N = 3, and G2 = 6.3 so Rdrp1 is 3k and Rdrp2 is 15.8kΩ.

These values are extremely sensitive to layout. Once the board has been laid out, some tweaking may be required to adjust the full load droop. This is fairly easy and can be accomplished by allowing the system to achieve thermal equilibrium at full load, and then adjusting Rdrp2 to obtain the desired droop value.

Power Monitor

The power monitor signal tracks the inductor current. Due to the dynamic operation of the load, the inductor current is pulsating and the power monitor signal needs to be filtered. If the RC filter is followed by an A/D converter, the input impedance of the A/D converter needs to be much larger than the resistor used for the RC filter. Otherwise, the input impedance of the A/D converter and the RC filter resistor will construct a resistor divider causing the A/D converter reading incorrect information. It is desirable to choose a small RC filter resistor in order to reduce the resistor divider effect. The ISL9506 comes with a very strong current sinking capability, users can use kΩ resistors for the RC filter. Some A/D converters might have 100kΩ input impedance, 1kΩ resistor

will cause 1% error. As shown in Figure 36, when the load is at 2.5A, PMON can still sink 0.6mA current. This allows the RC filter capacitor to discharge when the load is at low current, thus providing correct average power information on the capacitor.

Fault Protection - Overcurrent Fault Setting

As previously described, the overcurrent protection of the ISL9506 is related to the droop voltage. Previously we have calculated that the Droop Voltage = $I_{LOAD} * R_{droop}$, where Rdroop is the droop impedance. Knowing this relationship, the overcurrent protection threshold can be set up as a voltage droop level. Knowing this voltage droop level, one can program in the appropriate drop across the Roc resistor. This voltage drop will be referred to as Voc.

Once the droop voltage is greater than Voc, the PWM drives will turn off and PGOOD will go low. The selection of Roc is given in Equation 25. Assuming we desire an overcurrent trip level, loc, of 55A, and knowing from the desired specification that the droop impedance, Rdroop is 0.0021 (V/A), we can then calculate for Roc as shown in Equation 25:

$$R_{oc} = \frac{I_{oc} \times R_{droop}}{10\mu A} = \frac{55 \times 0.0021}{10 \times 10^{-6}} = 11.5k\Omega \quad (EQ. 25)$$

Note, if the droop impedance is not -0.0021 (V/A) in the application, the overcurrent setpoint will differ from predicted.

A capacitor may be added in parallel with Roc to improve noise rejection but the Roc*capacitor time constant cannot exceed 20μs. Do not remove Roc if overcurrent protection is not desired. The maximum Roc is 30k.

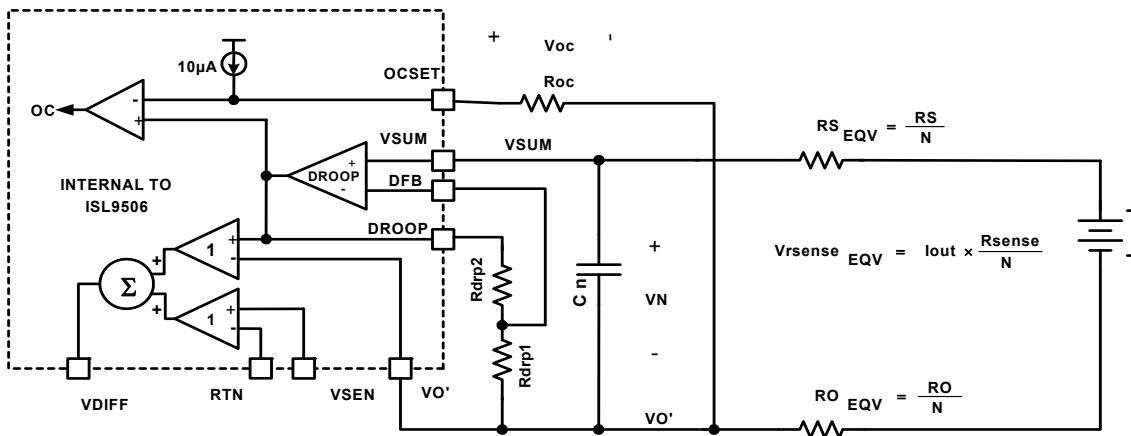

FIGURE 48. EQUIVALENT MODEL FOR DROOP AND REMOTE SENSING USING DISCRETE RESISTOR SENSING

**© Copyright Intersil Americas LLC 2005-2017. All Rights Reserved.
All trademarks and registered trademarks are the property of their respective owners.**

For additional products, see www.intersil.com/en/products.html

Intersil products are manufactured, assembled and tested utilizing ISO9001 quality systems as noted in the quality certifications found at www.intersil.com/en/support/qualandreliability.html

Intersil products are sold by description only. Intersil may modify the circuit design and/or specifications of products at any time without notice, provided that such modification does not, in Intersil's sole judgment, affect the form, fit or function of the product. Accordingly, the reader is cautioned to verify that datasheets are current before placing orders. Information furnished by Intersil is believed to be accurate and reliable. However, no responsibility is assumed by Intersil or its subsidiaries for its use; nor for any infringements of patents or other rights of third parties which may result from its use. No license is granted by implication or otherwise under any patent or patent rights of Intersil or its subsidiaries.

For information regarding Intersil Corporation and its products, see www.intersil.com

Package Outline Drawing

L40.6x6

40 LEAD QUAD FLAT NO-LEAD PLASTIC PACKAGE

Rev 3, 10/06

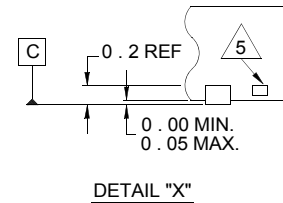
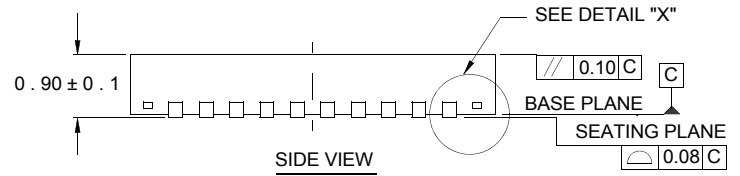
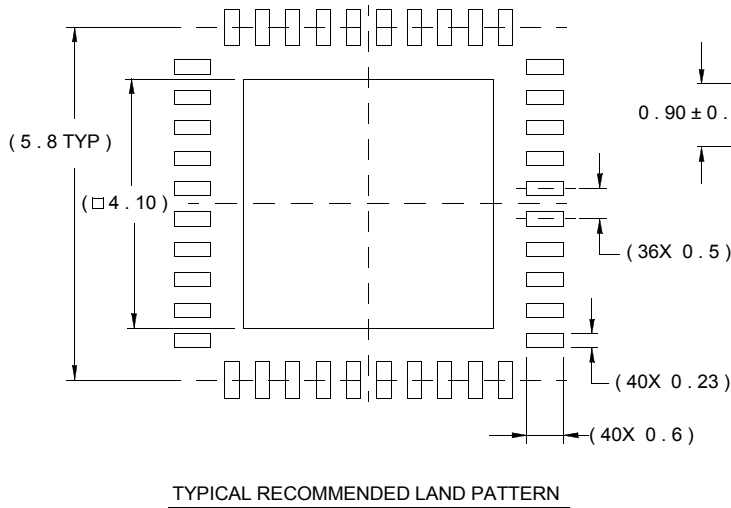
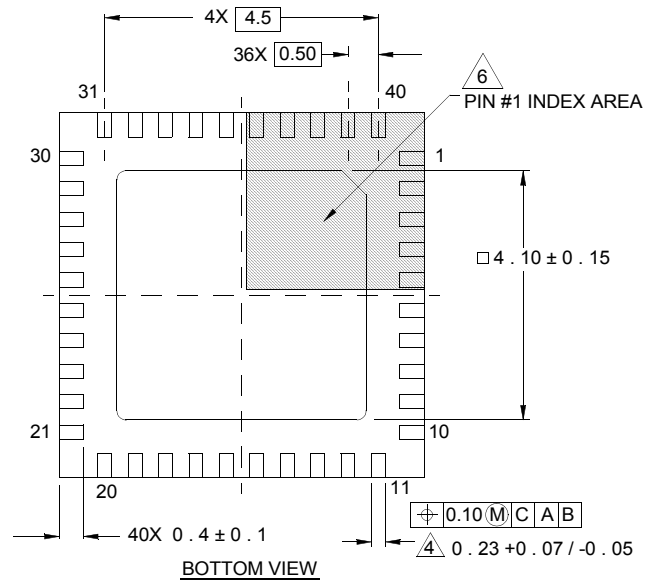
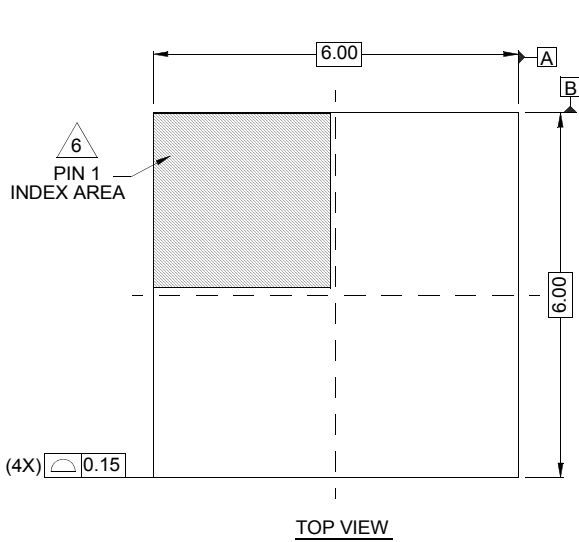

NOTES:

1. Dimensions are in millimeters.
Dimensions in () for Reference Only.
2. Dimensioning and tolerancing conform to AMSE Y14.5m-1994.
3. Unless otherwise specified, tolerance : Decimal ± 0.05
4. Dimension b applies to the metallized terminal and is measured between 0.15mm and 0.30mm from the terminal tip.
5. Tiebar shown (if present) is a non-functional feature.
6. The configuration of the pin #1 identifier is optional, but must be located within the zone indicated. The pin #1 identifier may be either a mold or mark feature.