



3.2 mm x 2.5 mm Ceramic Package SMD Oscillator,
LVCMOS / LVPECL / LVDS



ISM67 Series

Product Features

Small Surface Mount Package
Fast Sample Delivery
Fast Sample Delivery
Pb Free/ RoHS Compliant
Leadfree Processing

Applications

xDSL
Broadcast Video
Wireless Base Stations
Sonet /SDH
WiMAX/WLAN
Server and Storage
Ethernet/LAN/WAN
Optical modules
Clock and data recovery
FPGA/ASIC
Backplanes
GPON

Frequency LVCMOS LVPECL LVDS	10.000MHz to 250.000MHz 10.000MHz to 1500.000MHz 10.000MHz to 1500.000MHz
Output Level LVCMOS LVPECL LVDS	Logic "0" = 10% of Vcc max, Logic "1" = 90% of Vcc min Logic "0"= Vcc-1.62V max., Logic "1" = 1.02 V min VOD=(Diff. Output) 350mV Typ.
Duty Cycle LVCMOS LVPECL LVDS	50% ±5% @ 50% of Vcc 50% ±5% @ 50%* 50% ±5% @ 50%*
Rise / Fall Time LVCMOS LVPECL LVDS	2.0 ns max. (10% to 90%)* 0.8 ns max. (20% to 80%)* 0.8 ns max. (20% to 80%)*
Output Load LVCMOS LVPECL LVDS	15pF 50 Ω to Vcc - 2.0 VDC RL=100 Ω/CL= 5pF
Frequency Stability	See Table Below
Supply Voltage (Vcc)	+3.30 VDC ± 5%, +2.50 VDC ± 5%
Aging	±3.0 ppm max per year
Current	HCMOS = 45 mA max LVPECL = 90 mA max LVDS = 35 mA max
Phase Jitter (RMS) (12kHz to 20MHz)	0.9 ps typical
Operating Temp. Range	See Table Below
Storage Temp. Range	-40° C to +85° C

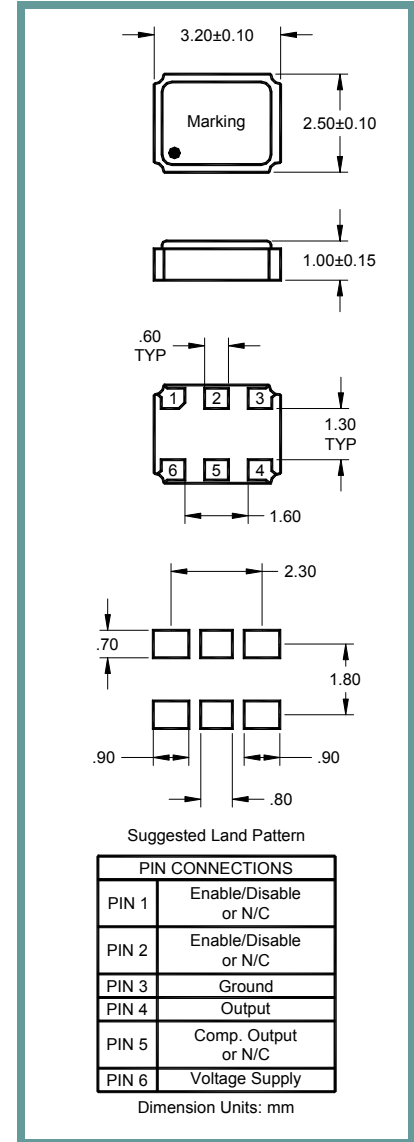

Part Number Guide		Sample Part Number: ISM67-31A9H2-155.520					
Package	Input Voltage	Operating Temperature	Stability (in ppm)	Output	Enable / Disable	Complimentary Ouput (Pin 5) **	Frequency
ISM67	3 = 3.3V	1 = 0° C to +70° C	F = ±20	3 = LVCMOS	H = Enable (Pin 1)	1 = N.C.	-155.520 MHz
	6 = 2.5V	2 = -40° C to +85° C	A = ±25	8 = LVDS	K = Enable (Pin 2)	2 = Output	
		3 = -20° C to +70° C	B = ±50	9 = LVPECL			

NOTE: A 0.01 μF bypass capacitor is recommended between V_{DD} (pin 6) and GND (pin 3) to minimize power supply noise. * Measured as percent of waveform. ** Available on LVDS and LVPECL ouput only.

**QUALITY SYSTEM
CERTIFIED
= ISO 9001 =**

ILSI America Phone 775-851-8880 • Fax 775-851-8882 •email: e-mail@ilsiamerica.com •
www.ilsiamerica.com
Specifications subject to change without notice

Rev: 03/10/15_A



3.2 mm x 2.5 mm Ceramic Package SMD Oscillator,
LVCMOS / LVPECL / LVDS



ISM67 Series

Typical Application:

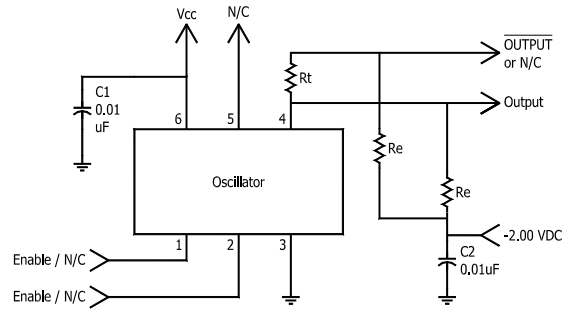
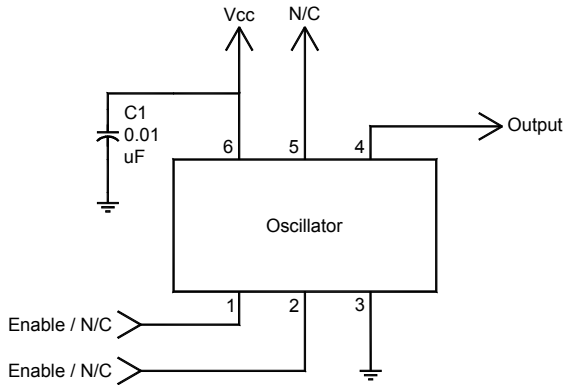

- Notes;
 1. LVPECL Load = Use Re and -2.0 VDC Source.
 2. LVDS Load = Omit Re and use Rt.

Pb Free Solder Reflow Profile:

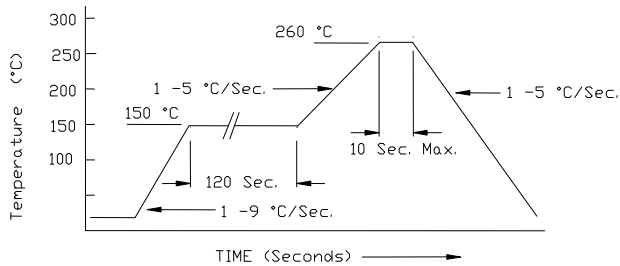

*Units are backward compatible with 240C reflow processes

Package Information:

MSL = N.A. (package does not contain plastic, storage life is unlimited under normal room conditions).
 Termination = e4 (Au over Ni over W base metallization).



3.2 mm x 2.5 mm Ceramic Package SMD Oscillator,
LVMOS / LVPECL / LVDS



ISM67 Series

Tape and Reel Information:

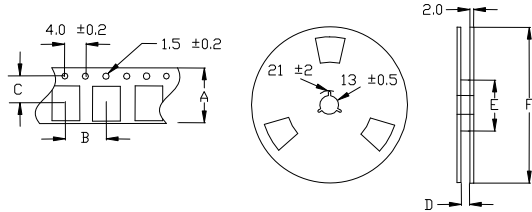

Quantity per Reel	1000
A	16 +/- .3
B	8 +/- .2
C	7.5 +/- .2
D	17.5 +/- .1
E	50 / 60 / 80
F	180 / 250

Environmental Specifications

Thermal Shock	MIL-STD-883, Method 1011, Condition A
Moisture Resistance	MIL-STD-883, Method 1004
Mechanical Shock	MIL-STD-883, Method 2002, Condition B
Mechanical Vibration	MIL-STD-883, Method 2007, Condition A
Resistance to Soldering Heat	J-STD-020C, Table 5-2 Pb-free devices (except 2 cycles max)
Hazardous Substance	Pb-Free / RoHS / Green Compliant
Solderability	JESD22-B102-D Method 2 (Preconditioning E)
Terminal Strength	MIL-STD-883, Method 2004, Test Condition D
Gross Leak	MIL-STD-883, Method 1014, Condition C
Fine Leak	MIL-STD-883, Method 1014, Condition A2, R1=2x10 ⁻⁸ atm cc/s
Solvent Resistance	MIL-STD-202, Method 215

Marking

Line 1: ILSI and Date Code (YWW)
Line 2: Frequency

PROPRIETARY AND CONFIDENTIAL

THIS DOCUMENT CONTAINS PROPRIETARY INFORMATION, AND SUCH INFORMATION MAY NOT BE DISCLOSED TO OTHERS FOR ANY PURPOSE NOR USED FOR MANUFACTURING PURPOSES WITHOUT WRITTEN PERMISSION FROM ILSI America.