

## ISO 4011 Series Multirange,High Accuracy Analog Input, Data Acquisition Modules

### Features

- Single-channel analog signal-conditioning modules,isolated RS-485/232 output
- Testing accuracy>0.05%
- Can be remotely reconfigured for modules accuracy and input ranges
- Three-port isolation(input/output/assistant power supply): 3000VDC
- Power supply:24VDC/15VDC/12VDC/5VDC
- High reliability,easy programme,installation.
- Temperature sensors for offsetting thermocouple cold port
- J/ K/ T/ E/ R/ S/ B thermocouple input
- $\pm 15$  mV/  $\pm 50$  mV/  $\pm 100$  mV/  $\pm 500$  mV millivolt small signal input
- $\pm 1$  V /  $\pm 2.5$  V voltage signals or  $\pm 20$  mA current signals input

### Applications

- Temperature signal testing/monitoring/cintrol
- RS-232/485 industrial automation control system
- Industial field signal isolation
- Process Monitoring & Control
- Test sensors signal
- Laboratory Data Acquisition
- Medical machine monitoring
- 4-20mA/0-20mA signal acquisition

### Product Overview

ISO40xx series realizes sensor-to-host signal acquisition for testing analog signal or remote applications. Software-configurable for a wide variety of sensor types, including: analog input, analog output, and digital I/O,ISO40xx series are widely used in RS-232/485 automation control system,temperature signal testing,small signal testing, Monitoring & Control, remote data acquisition applications.

Including power supply isolation, signal isolation, linearization, A/d conversion and RS-232C/RS-485 serial communication. for up to 256 channels per serial port, ISO40xx Series modules,adopts ASCII format and MODBUS,its injunction fully encapsulated to ADAM modules,baud rate can be intercalated by code,can be used in the same RS-485 lines with other manufacturers modules,convenient for computer-programme.

ISO40xx series modules is SCM-based intelligent monitoring and control system, with all calibration,High and Low alarm, address,input ranges,baud rate,data format and linearizing parameters stored in EEPROM non-volatile memory. ISO 40xx series modules can test variety of sensor types,including thermocouple and RTD ,and other a wide variety of input ranges,different modules that need to be used in a given application and carried in inventory.

ISO40xx series modules are designed as industrial standard,three-port isolation (input/output/power supply),3000VDC isolated.Temperature range is - 45°C to +85°C.

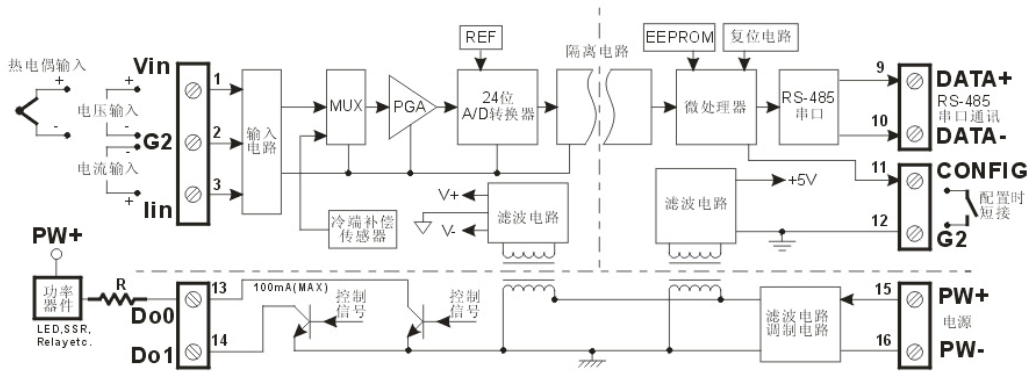

Figure 1 FUNCTIONAL BLOCK DIAGRAM

### ISO 4011 Function Description

ISO 4011 is single-channel isolated signal-conditioning modules. Accepts outputs from Thermocouple, millivolt, volt and current signals.

#### Analog Input Module:

24-bit accuracy, have been calibrated all signal input before ex-factor. Also, Users can programme himself when modules working. Thermocouple input break line testing, linearity compensation and cold port temperature compensation.

#### Communication software:

Communication Interface: Module has one standard RS-485 interface

Communication agreement: Standard ASCII, MODBUS, can make network communicate with PLC, RTU or watch software.

Data format: 10-bit, 1 start bit, 8 data bits, 1 stop bit, no parity. (N, 8, 1)

Communication address (0~255) and baud rate (300、600、1200、2400、4800、9600、19200、38400bps), Max. communication distance: 1200m, connect by both twists shielded cable.  $\pm 15KV$  ESD protection, communication response time is less than 70mS.

#### (2-wire) Alarm signaling output:

When choose products with alarm function, output two channels switching alarm signal, they are used to high&low control and alarm.

#### Anti-jamming:

Set checksum according to need. Its inside contains MOMENTARY bate diode.

## Products Choose

## ISO 4011 - P□ - □

Assistant power supply

P1: DC24V P2: DC12V  
 P3: DC5V P4: DC15V  
 P5: user-defined

Additional code

Default: one channel RS-485 interface  
**A**:with alarm funcion  
 one channel RS-485 interface  
**B**:one channel RS-485 interface or  
 RS-232 interface(Key-press Choice)  
**AB**: with alarm funcion one channel  
 RS-485or RS-232 interface(Key-press Choice)

## ISO4011 General Parameters

(typical @ +25°C, Vs is rated value)

**Inputs, Software Selectable**

Millivolt Inputs: ±50 mV, ±100 mV, ±500 mV

Volt/current Inputs: ±1 V, ±2.5 V, ±20 mA

Thermocouples: J(0°C ~ 760°C), K(0°C ~ 1000°C), T(-100°C ~ 400°C), E(0°C ~ 1000°C),  
 R(500°C ~ 1750°C), S(500°C ~ 1750°C), B(500°C ~ 1800°C)

Accuracy: @ +25°C refer to figure 1

Input Maladjustment: ±0.02 uV/°C

Temperature Drift: ±1 ppm/°C (±3 ppm/°C, max)

Input Resistance: 100 MΩ

Bandwidth: Thermocouple, ±15 mV, ±15 mV -3 dB 3.27 Hz  
 ±100 mV, ±500 mV, ±1 V, ±2.5 V, ±20 mA -3 dB 12.7 Hz

Conversion Speed: Thermocouple, ±15 mV, ±15 mV 3.76 Sps  
 ±100 mV, ±500 mV, ±1 V, ±2.5 V, ±20 mA 15.0 Sps

Common-Mode Rejection(CMR): 120 dB (1kΩ Source Imbalance @ 50/60 Hz)

Normal Mode Rejection (NMR): 60 dB (1kΩ Source Imbalance @ 50/60 Hz)

Input port protection: 240Vrms, continuous

ANSI/IEEE C37.90.1-1989 Momentary protection

**Cold Junction Compensation Sensor**

Accuracy: @+25°C ±0.25°C (±0.75°C, max)

Accuracy: +5°C ~ +45°C ±0.5°C (non-linearity ±0.0125°C/°C)

**Communications**

Protocol RS-485 ASCII format, MODBUS

Baud Rates Software Selectable (300, 600, 1200, 2400, 4800, 9600, 19200, 38400bps)

Address (0~255) Software Selectable

Synchronized Sampling Command: Yes

Response Time: 70 ms, max

Digital output: Two channels on-off, each current is 100mA(Max.)

Operation Power: DC5V/12V/ 15V/24V(±10%)

Power Lost: ≤1W

Operation Temperature: - 45 ~ +85°C

Operation Humidity: 10 ~ 90% (non-condensing)  
 Storage Temperature: - 45 ~ +85°C  
 Storage Humidity: 10 ~ 95% (non-condensing)  
 Isolation: 3KVDC,1 minute,leak current:1mA  
 Endure Impact Voltage: 3KVAC,1.2/50us(peak value)  
 Mechanical Dimensions: 101 mm x 23 mm x 116.5 mm

**ISO 4011 Specifications: typical @+25°C Vs(rated value)**

Input Range Description	Accuracy (Typical)	Accuracy (Maximum)	Noise (Peak-to-Peak)
±15 mV	±0.02 % FS	±0.05 % FS	±0.02 % FS
±50 mV	±0.015 % FS	±0.04 % FS	±0.01 % FS
±100 mV	±0.01 % FS	±0.03 % FS	±0.005 % FS
±500 mV	±0.01 % FS	±0.03 % FS	±0.005 % FS
±1 V	±0.005 % FS	±0.02 % FS	±0.002 % FS
±2.5 V	±0.005 % FS	±0.02 % FS	±0.002 % FS
±20 mA	±0.005 % FS	±0.02 % FS	±0.002 % FS
Type J thermocouple,0°C~760°C	±0.2°C	±0.4°C	±0.12°C
Type K thermocouple,0°C~1000°C	±0.25°C	±0.5°C	±0.2°C
Type T thermocouple,-100°C~400°C	±0.2°C	±0.35°C	±0.15°C
Type E thermocouple,0°C~1000°C	±0.18°C	±0.4°C	±0.1°C
Type R thermocouple,500°C~1750°C	±0.3°C	±0.8°C	±0.22°C
Type S thermocouple,500°C~1750°C	±0.3°C	±0.75°C	±0.2°C
Type B thermocouple,500°C~1800°C	±0.4°C	±0.9°C	±0.3°C

**Table 1** ISO 4011 test accuracy

Note: thermocouple accuracy error does not include the sensor temperature error

**Footprint Function and Dimension:**

**Table 1**

Footprint	Name	
1	Vin	+ voltage input
2	G1	Input port ground
3	Iin	+ current input
4	NC	NO Pin
5	NC	NO Pin
6	NC	NO Pin
7	NC	NO Pin
8	NC	NO Pin
9	DATA+	RS-485signal in series, + (note1)
10	DATA-	RS-485 signal in series,- (note 1)
11	CONFIG	Initializte state set
12	G2	Output port ground
13	Do0	Low alarm output (note 2)
14	Do1	High alarm output (note2)
15	PW+	Power +



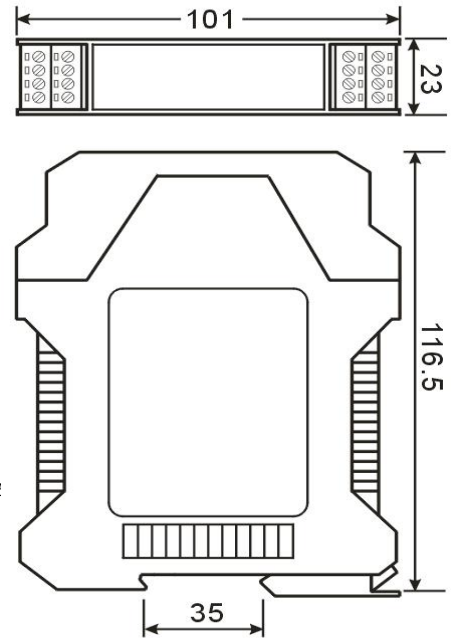
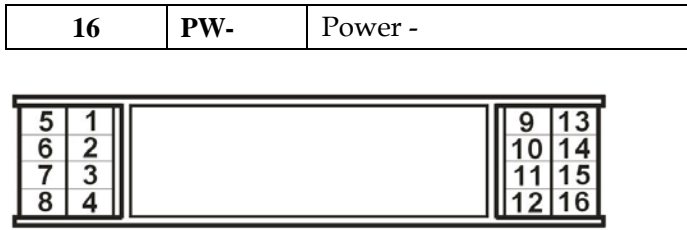

**Note 1:**when output is RS-232, output connection refer to Figure 2

**Note 2:**when output without alarm,13,14 are NO Pin.

Do0, Do1 is switching output port,wiring diagram refer to Figure 1.when alarm, Do0, Do1 audion pass.

**Wiring Diagram:**

Module connecting refer to Figure 1.Broken line divides module Into three isolated parts:Signal input,RS-485/RS-232 interface /assistant power supply and alarm output.Power supply and Alarm output are been connected into interiorly,when products With alarm function.Limit resistance R is used to limit current. Max.:100mA,suggest current value:5~10mA

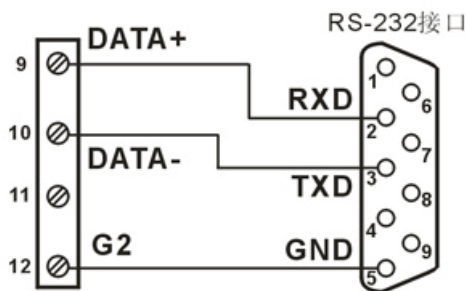

Figure 2 ISO 4011-P-A and RS-232 Wiring Diagram

**RS-232 Interface**

When part No. is ISO 4011-P-B(or AB), user can choose RS-485 output or RS-232 output by internal keyswitch.Open product’s coping,may see two button switching in the board,all aren’t pressed is RS-485 output,two pressed is RS-232 output.When choose RS-232 output,please refer to Figure 2,9,10,12 separately connects to RS-232 interface RXD,TXD,GND.

**Alarm Signaling**

ISO 4011-P-A(or AB) analog input modules include High and Low alarm functions. High and Low alarm limits may be downloaded into the module’s EEPROM by the host computer.

The alarm functions can be enabled or disabled remotely. When the alarm function is enabled, both Digital Output channels are used to indicate the High and Low alarm state. Digital Output channel 1 (DO1) equals to High alarm state, and Digital Output channel 0 (DO0) equals to Low alarm state. The High and Low alarm states can be read at any time by the host computer.

Every A/D conversion will be followed by a comparison with the High and Low limit.

When the input value exceeds one of these limits, the High or Low alarm state is set to ON.

There are two alarm mode options, Momentary and Latching.

If the alarm is in Latching mode, the alarm will stay on even if the input value returns within the limits. An alarm in Latching mode can be turned OFF by giving a Clear Alarm command from the host computer. A Latching alarm is cleared by the module when the opposite alarm is set. When the module receives a value that is lower than the Low alarm limit, it will clear the High alarm and turn the Low alarm ON.

When the alarm is in Momentary mode, the alarm will be turned OFF as soon as the input value returns within the limits.

### Initialization ISO 40xx Module

All ISO 40xx modules use RS-485 network, must distribute a only one address, between 00 and FF(hexadecimal), but, all new ISO 40xx modules use a factory initialization set. As follows:

Address: 00 (hexadecimal)

Baud rate: 9600 bps

Checksum: disabled

Because address codes of new module are the same, their address will conflict to other modules, you must reconfigured every analog input address when you configure system. You can amend ISO40xx address by set command, after connecting ISO40xx power line and RS485.

Baud rate, checksum state also need been adjusted according to users' need. You must install leap line before you amend baud rate, checksum state. All ISO40xx modules have a Pin mark with CONFIG. connect CONFIG Pin to ground (G2 pin), then connect power supply, this time they are in listening mode. Its set is as follows:

Address :00

Baud rate 9600 bps

Checksum: disabled

### Command

Every command is used of a series characters, such as leading code, address ID, command, checksum, carriage return cr. Host computer is with “\*” synchronous command, only command a ISO40xx module once.

Command format: **(delimiter character)(Addr)(Command)[data][checksum](cr)**

**(delimiter character)** is the first letter of command. All commands need a leading code. such

as: %, \$, #, @, ...

**1-Character**

**(Addr)** is module address code, if the following does not appoint, value range is 00~FF

(hexadecimal)

**2-Character**

**(Command)** represents command code or variable value

**Variable Length**

**[data]** some output command need data

**Variable Length**

**[checksum]** represents optional parameters, only need it when checksum is enabled.

**2-Character**

**(cr)** a control code as identify, is a terminating character, value is 0x0D

**1-character**

When checksum is enabled, need [Checksum]. The delimiter character is followed by a two-character address (hexadecimal) that specifies the target module. Command and response must append checksum characteristic. Checksum is used to check all input

command, to help you find the errors between host computer and module command  
Checksum characters are followed by command or response character, but ahead carriage return character.

Method: two-character (hexadecimal), is the sum of all sending characters ASCII, then AND 0xFF.

Example: Disable checksum

command: **\$002(cr)**

response: **!00020600 (cr)**

Enable checksum

command: **\$002B6 (cr)**

response: **!00020600 A9 (cr)**

'\$' = 0x24    '0' = 0x30    '2' = 0x32

$B6 = (0x24 + 0x30 + 0x30 + 0x32) \text{ AND } 0xFF$

'!' = 0x21    '0' = 0x30    '2' = 0x32    '6' = 0x36

$A9 = (0x21 + 0x30 + 0x30 + 0x30 + 0x32 + 0x30 + 0x36 + 0x30 + 0x30) \text{ AND } 0xFF$

Generally analog input module command table:

- 1、 Read Analog Input Module Data
- 2、 CJC State Command
- 3、 CJC Offset Calibration
- 4、 Set Module
- 5、 Read Set State
- 6、 Offset Calibration
- 7、 Span Calibration
- 8、 Synchronized Sampling
- 9、 Read Synchronized Data Command
- 10、 Open Thermocouple Detection Command
- 11、 Read Module Name
- 12、 Set Digital I/O State And Alarm State command
- 13、 Read Digital I/O State And Alarm State command
- 14、 Enable Alarm command
- 15、 Disable Alarm command
- 16、 Clear Latch Alarm Command
- 17、 Set High Alarm Limit Command
- 18、 Set Low Alarm Limit Command
- 19、 Read High Alarm Limit Command
- 20、 Read Low Alarm Limit Command

Response :

Response depends on all kinds of command. It is formed some characters, such as delimiter character, variable and carriage return sign. Its leading codes has '!' or '>', represents command is valid, '?' is invalid. So that can watch command whether is valid by testing response information.

**Note: 1、 ALL COMMANDS SHOULD BE ISSUED IN UPPERCASE CHARACTERS!**

**3、 Command 12~20 is only valid to ISO 4011-P□-A(or AB).**

## 1、 Read Analog Input Data command

**Describe:** Returns the input value from a specified analog input module in the currently configured data format

**Syntax:** #AA(cr)

# delimiter character

AA is (range 00-FF) represents the 2-character hexadecimal address of the module.

(cr) is the terminating character, carriage return (0Dh)

**Response :** >(data)(cr) command is valid.。

?AA(cr) invalid command or nonlicet operation

> delimiter character

(data) Returns data.The data format is in Engineering Units, Percent of FSR, Two's complement hexadecimal,or ohms. Refer to Chapter 4 Command Set.

(cr) terminating character, carriage return (0Dh)

There is no response if the module detects a syntax error or communication error or if the specified address does not exists.

**NOTICE:** When modules measure Thermocouple or RTD input values that are outside their Span Value if thermocouple implies input out of bounds. It can send out testing command \$AAB(cr) for testing.( Refer to Chapter 10 Command Set. )

**Example:** command #23(cr)

Response >+4.7653(cr)

The analog input module value is +4.7653V at adres 23H (Data formats is engineer units)

## 2、 CJC State Command

**Description:** Returns the value of the CJC sensor for a specified analog input module

**Command Syntax:** \$AA3(cr)

\$ delimiter character

AA module address, (range 00-FF) represents the 2-character hexadecimal

3 indicates CJC state command

(cr) terminating character, carriage return (0Dh)

**Response:** >(data)(cr) command is valid

?AA(cr) command is invalid.

> delimiter character which indicates a valid command.

? delimiter character which indicates a invalid command.

(data) is sensor value,unit is °C.data formats:plus (+) or minus (-) sign, followed by five algorism digits and a decimal point, the resolution of the data is 0.1)

AA represents input module address

(cr) terminating character, carriage return (0Dh)

There is no response if the module detects a syntax error or communication error or if the specified address does not exists.

**Example:** command \$233(cr)

Response >+0024.9(cr)

CJC sensor temperature responds with: 24.9°C at address 23H.



### 3、CJC Offset Calibration Command

**Description:** Calibrates an analog input module to adjust for offset errors of its CJC (Cold Junction Compensation) sensors.

**Command Syntax:** \$AA9(Counts)(cr)

\$ delimiter character

AA module address, (range 00-FF) represents the 2-character hexadecimal

(Counts) CJC offset value, Windows default is 0000, it is a four character hexadecimal, sign, + or -, The value can range from 0000 to FFFF. Each count equals approximately 0.009°C

Example: +006F = 6 \* 16 + 15 = 111

111 \* 0.009°C = 0.999°C

(cr) terminating character, carriage return (0Dh)

**Response:** !AA(cr) command is valid

?AA(cr) command is invalid.

**Example:** command %239+006F(cr)

Response !23(cr)

Compensate to the CJC offset of address 23H, offset temperature is +006F = 6 \* 16 + 15 = 111, 111 \* 0.009°C = 0.999°C.

### 4、Set Analog Input Module Command

**Description:** Set address, input ranges, baud rate, data formats, checksum and state for an analog input module, counter data are stored in an EEPROM.

**Syntax:** %AANN TTCCFF(cr)

% delimiter character

AA module address, (range 00-FF) represents the 2-character hexadecimal

NN indicates new module hexadecimal address, value NN range is 00~FF

TT hexadecimal indicates type code. Type code indicates input range, input module type code is in Table 5.

**Table 5** Analog Input Module Type Code

**CC** Baud Rate code (hexadecimal)

Baud rate code	Baud rate
01	300 baud
02	600 baud
03	1200 baud
04	2400 baud
05	4800 baud
06	9600 baud
07	19200 baud
08	38400 baud

**Table 3** Baud rate code

**FF** (8-bit parameter) hexadecimalre presents data formats,checksum.

Bit7	Bit 6	Bit 5	Bit 4	Bit 3	Bit2	Bit 1	Bit 0
------	-------	-------	-------	-------	------	-------	-------

**Table 4** Data format,checksum

**Bit7:** Not used(set to 0)

**Bit6:** checksum states,if 0: Disabled,if 1: Enabled

**Bit5-bit2:** Not used(set to 0)

**Bit1-bit0:** Data Format Bit

00: Engineering Units

01: % of FSR

10: Twos complement hexadecimal

11: ohms

(**cr**) terminating character, carriage return (0Dh)

**Response: !AA(cr)** command is valid

**?AA(cr)** command is invalid or nonlicet operation, or do not set up line before changing baud rate or checksum

Model No.	Type Code (TT)	Input Range
<b>ISO 4011</b>	00	±15mV
	01	±50mV
	02	±100mV
	03	±500mV
	04	±1V
	05	±2.5 V
	06	±20mA
	0E	Type J thermocouple,0°C ~760°C
	0F	Type K thermocouple,0°C ~1000°C
	10	Type T thermocouple,-100°C ~400°C
	11	Type E thermocouple,0°C ~1000°C
	12	Type R thermocouple,500°C ~1750°C
	13	Type S thermocouple,500°C ~1750°C
	14	Type B thermocouple,500°C ~1800°C

- ! delimiter character which indicates a valid command.
- ? delimiter character which indicates a invalid command.
- AA represents input module address
- (cr) terminating character, carriage return (0Dh)

If you configure module for the first time, AA=00、 NN equals to new address.If reconfigure module changing address,input range,data formats,AA equals to present or new address.If reconfigure module changing baud rate or checksum state, must install command string,make them in listening mode,module address is 00H,also AA=00H,NN=present or new address.

There is no response if the module detects a syntax error or communication error or if the specified address does not exists.

**Example: command %0011050600(cr)**  
**Response !11(cr)**

**Description:** % delimiter character  
 00 indicates analog input module initial address that you want to set is 00H  
 11 indicates new module hexadecimal address is 11H  
 05 indicates input range:±2.5 V  
 06 indicates baud rate:9600 baud  
 00 indicates data format is Engineering Units, checksum is disabled

## 5、 Read Set State Command

**Description:** Read set for the specified a analog input module.

**Syntax: \$AA2(cr)**  
 \$ delimiter character  
 AA module address, (range 00-FF) represents the 2-character hexadecimal  
 2 indicates read set state command  
 (cr) terminating character, carriage return (0Dh)

**Response:** !AATTCCFF(cr) command is valid  
 ?AA(cr) command is invalid or nonlicet operation  
 ! delimiter character  
 AA represents input module address  
 TT Type Code,Table 5  
 CC Baud rate code,Table 3  
 FF Table 4  
 (cr) terminating character, carriage return (0Dh)

There is no response if the module detects a syntax error or communication error or if the specified address does not exists.

**Example: command \$302(cr)**  
**Response !300F0600(cr)**

- ! delimiter character
- 30 indicates analog input module address is 30H
- 0F indicates that input is K,testing range is 0°C ~ 1000°C
- 06 represents that baud rate is 9600 baud
- 00 represents that data format is Engineering Units,disable checksum

## 6、 Offset Calibration Command

**Description:** Calibrates an analog input module to correct for offset errors

**Syntax:** \$AA1(cr)

\$ delimiter character

AA module address, (range 00-FF) represents the 2-character hexadecimal

1 represents offset calibration command

(cr) terminating character, carriage return (0Dh)

**Response:** !AA (cr) command is valid

?AA(cr) command is invalid or nonlicet operation

! delimiter character which indicates a valid command.

? delimiter character which indicates a invalid command.

AA represents input module address

(cr) terminating character, carriage return (0Dh)

Products have been calibrated,user can use them directly.After calibrating offset command,then calibrate gain errors.

In order to successfully calibrate an analog input module's input range, a proper calibration input signal should be connected to the analog input module before and during the calibration. (See following Calibration information)

There is no response if the module detects a syntax error or communication error or if the specified address does not exist.

**Example:** command \$231(cr)

Response !23 (cr)

Calibrate offset for address 23H module.

## 7、 Span Calibration Command

**Description:** Calibrates an analog input module to correct for gain errors

**Syntax:** \$AA0(cr)

\$ delimiter character

AA module address, (range 00-FF) represents the 2-character hexadecimal

0 represents gain calibration commandre

(cr) terminating character, carriage return (0Dh)

**Response:** !AA(cr) command is valid

?AA(cr) command is invalid or nonlicet operation

! delimiter character which indicates a valid command.

? delimiter character which indicates a invalid command.

AA represents input module address

(cr) terminating character, carriage return (0Dh)

Products have been calibrated,user can use them directly.After calibrating offset command,then calibrate gain errors.

In order to successfully calibrate an analog input module's input range, a proper calibration input signal should be connected to the analog input module before and during the calibration. (See following Calibration information)

There is no response if the module detects a syntax error or communication error or if the specified address does not exists.

**Example:**    **command**    **\$230(cr)**  
                   **Response**    **!23 (cr)**

Calibrate gain errors for address 23H module.

## 8、 Synchronized Sampling command

**Description:** Orders all analog input modules to sample their input values and store them in special registers.Returns synchronized testing data by carrying out synchronized data command.

**Syntax:**    **##\***

**#**        delimiter character

**\*\***       represents Synchronized Sampling command

The analog input modules will send no response after executing the synchronized sampling command. In order to retrieve the data, Read Synchronized Data command has to be issued for every analog input module. It need some time for carrying out converter,so between carrying out Synchronized Sampling command and carrying out read Synchronized Data command,need delay 70ms.The module returns a wrong response if converter previous Synchronized Data.

## 9、 Read Synchronized Data Command

**Description:** Returns the value that was stored in the specified module's register after the **##\*** command.

**Syntax:**    **\$AA4(cr)**

**\$**        delimiter character

**AA**     module address, (range 00-FF) represents the 2-character hexadecimal

**4**       read Synchronized Data Command

**(cr)**    terminating character, carriage return (0Dh)

**Response:** **!AA(status)(data) (cr)**    command was valid

**?AA(cr)**    the command was invalid

**!**        delimiter character which indicates a valid command.

**?**        delimiter character which indicates a invalid command.

**AA**     represents input module address

**(status)** will tell you if the data (data) from the last Synchronized Sampling command (**##\***) has already been sent.

        If status = 1, then the data has been sent for the first time since a Synchronized Sampling command was issued.

        If status = 0, then the data has been sent at least once

**before.** Represents whether Synchronized Sampling data in the register are been sent,after sending out the last Synchronized Sampling command.

        If status=1, Synchronized Sampling datas in a register are been sent for the first time.

        If status = 0, then the data has been sent at least once

**(data)** a value stored in a special register of the interrogated module in the configured data format. It has been sampled by the module after the last Synchronized Sampling command has been sent.

(cr) terminating character, carriage return (0Dh)

It need some time for carrying out converter,so between carrying out Synchronized Sampling command and carrying out read Synchronized Data command,need delay 70ms.The module returns a wrong response if converter before Synchronized Data.

There is no response if the module detects a syntax error or communication error or if the specified address does not exists.

**Example: command \$064(cr)**  
**Response !060+12.001 (cr)**

Read Synchronized Data at address 06h.Analog input module send its analog input data +12.001(units).State=0,which means that it has sent the same data at least once before,(Configured data format of the analog input module in this case is engineering units.)

**Example: command \$064(cr)**  
**Response !061+15.999 (cr)**

Read Synchronized Data at address 06h.Analog input module send its analog input data +15.999(units).State=1,which means that this is the first time that the data has been sent.(Configured data format of the analog input module in this case is engineering units.)

## 10、 Open Thermocouple Detection Command

**Description:**Detect whether thermocouple is opened or closed.

**Syntax: \$AAB(cr)**

\$ delimiter character

AA module address, (range 00-FF) represents the 2-character hexadecimal

B is open thermocouple Detection Command

(cr) terminating character, carriage return (0Dh)

**Response: !AA0(cr)** If thermocouple is closed

**!AA1(cr)** If thermocouple is opened.

**?AA(cr)** command is invalid or nonlicet operation,or no thermocouple signal input

! delimiter character which indicates a valid command.

? delimiter character which indicates a invalid command.

AA represents input module address

(cr) terminating character, carriage return (0Dh)

There is no response if the module detects a syntax error or communication error or if the specified address does not exists.

**Example: command \$06B(cr)**  
**Response !060 (cr)**

Thermocouple is closed at address 06H.

## 11、 Read Module Name Command

**Description:** Return the module name from the specified analog input module

**Syntax: \$AAM(cr)**

\$ delimiter character

AA module address, (range 00-FF) represents the 2-character hexadecimal

M represents Read module name command

(cr) terminating character, carriage return (0Dh)

**Response:!**AA(ModuleName)(cr) command is valid

?AA(cr) command is invalid or nonlicet operation

! delimiter character which indicates a valid command.

? delimiter character which indicates a invalid command.

AA represents input module address

(ModuleName) is ISO4011or ISO4012and so on, represents your module type

(cr) terminating character, carriage return (0Dh)

There is no response if the module detects a syntax error or communication error or if the specified address does not exists.

**Example: command \$08M(cr)**

**Response !08ISO4011 (cr)**

Counter Module is ISO4011 at adress 08H

## 12、 Set Digital I/O State And Alarm State command

**Description: Set a analog input alarm state, counter data are stored in a EEPROM.**

**Syntax: @AADO(data)(cr)**

@ delimiter character

AA module address, (range 00-FF) represents the 2-character hexadecimal

DO is the Set Digital Input/Output State Alarm State command

(data) represents alarm status mode(two hexadecimal numbers)

00 all digital input/output function are OFF

01 DO0 is ON, DO1 is OFF

02 DO0 is OFF, DO1 is ON

03 all digital input/output function are ON

(cr) terminating character, carriage return (0Dh)

**Response:!**AA (cr) command is valid

?AA(cr) command is invalid or nonlicet operation

! delimiter character which indicates a valid command.

? delimiter character which indicates a invalid command.

AA indicates input module address

(cr) terminating character, carriage return (0Dh)

There is no response if the module detects a syntax error or communication error or if the specified address does not exists.

**Example: command @15DO01 (cr)**

**Response !15 (cr)**

Set analog input module digital input/output DO0 is ON,DO1 is OFF at address 15H

## 13、 Read Digital I/O State And Alarm State command

**Description: Read dagital I/O state and alarm state for the specified a analog module.**

**Syntax: @AADI(cr)**

@ delimiter character

AA module address, (range 00-FF) represents the 2-character hexadecimal

DI is the Read Digital Input/Output State Alarm State command

(cr) terminating character, carriage return (0Dh)

**Response: ! AA**(cr) command is valid

?AA(cr) command is invalid or nonlicet operation

! delimiter character which indicates a valid command.

? delimiter character which indicates a invalid command.

AA indicates module address

S represents alarm status mode(a hexadecimal number)

0 alarm is disabled

1 MOMENTARY mode enabled

2 LATCH mode enabled

**OO Represents the Digital Output status and Alarm State command(two hexadecimal numbers)**

00 all digital input/output function are OFF

01 DO0 is ON, DO1 is OFF

02 DO0 is OFF, DO1 is ON

03 all digital input/output function are ON

**II Digital Input port's channel status (two hexadecimal numbers)**

00 represents digital input port's channel is low level

01 represents digital input port's channel is high level

(cr) terminating character, carriage return (0Dh)

There is no response if the module detects a syntax error or communication error or if the specified address does not exists.

**Example: command @12DI (cr)**

**Response !1210100 (cr)**

At address 12H,module momentary alarm function is ON,digital output DO0 is ON, DO1 is OFF,digital input port's channel is low level.

#### 14、 Enable Alarm command

**Description: Enables the alarm in either Momentary or Latching mode**

**Command Syntax: @AAEAT(cr)**

@ delimiter character

AA module address, (range 00-FF) represents the 2-character hexadecimal

EA is the Enable Alarm command.

T alarm types:M or L.

M: MOMENTARY

L: LATCH

(cr) terminating character, carriage return (0Dh)

**Response: ! AA (cr)** command is valid

?AA(cr) command is invalid or nonlicet operation

! delimiter character which indicates a valid command.

? delimiter character which indicates a invalid command.

AA indicates module address

(cr) terminating character, carriage return (0Dh)

There is no response if the module detects a syntax or communication



error, or even if the specified address does not exist.

**Example: command: @02EAM (cr)**  
**response: !02 (cr)**

Module enable the momentary Alarm Function at address 02h.

## 15、 Disable Alarm command

**Description: Disable Alarm for the specified a analog module.**

**Syntax:: @AADA(cr)**

**@** delimiter character  
**AA** module address, (range 00-FF) represents the 2-character hexadecimal  
**DA** is the Disable Alarm command  
**(cr)** terminating character, carriage return (0Dh).

**Response: ! AA (cr)** command is valid

**?AA(cr)** command is invalid or nonlicet operation  
**!** delimiter character, indicates a valid command  
**?** delimiter character, indicates a invalid command  
**AA** is input module adress  
**(cr)** terminating character, carriage return (0Dh)

There is no response if the module detects a syntax or communication error, or even if the specified address does not exist.

**Example: command @07DA (cr)**  
**Response !07 (cr)**

Alarm functions have been disabled at address 07H.

## 16、 Clear Latch Alarm Command

**Description: Both alarm states (High and Low) of the addressed analog input module are set to OFF, no alarm.**

**Command :@AACA(cr)**

**@** command is valid  
**AA** module address, (range 00-FF) represents the 2-character hexadecimal  
**CA** is the Clear Latch Alarm command.  
**(cr)** terminating character, carriage return (0Dh)

**Response: ! AA (cr)** command is valid

**?AA(cr)** command is invalid or nonlicet operation  
**!** delimiter character indicates a valid command was received.  
**?** delimiter character, indicates a invalid command  
**AA** is input module adress  
**(cr)** terminating character, carriage return (0Dh)

There is no response if the module detects a syntax or communication error, or even if the specified address does not exist.

**Example: command @02CA (cr)**  
**Response !02 (cr)**

The analog input module at address 02H is instructed to set both alarm states (High and Low) to OFF.

## 17、 Set High Alarm Limit Command

**Description: Set a analog input high-alarm count value, counter data are stored in a nonvolatile EEPROM.**

**Command: @AAHI(data)(cr)**

@ delimiter character

AA module address, (range 00-FF) hexadecimal

HI is set high-alarm command

(data) is high-alarm value,data formats is Engineering Units(plus (+) or minus (-) sign, followed by five decimal digits and a decimal point.)

(cr) terminating character, carriage return (0Dh)

**Response:!AA (cr)** command is valid

?AA(cr) command is invalid or nonlicet operation

! delimiter character, indicates a valid command

? delimiter character, indicates a invalid command

AA is input module address

(cr) terminating character, carriage return (0Dh)

There is no response if the module detects a syntax or communication error, or even if the specified address does not exist.

**Example: command @15HI+0700.0 (cr)**

**Response !15 (cr)**

Set analog input module J type thermocouple input high-alarm is 700°C at address 15H.

## 18、 Set Low Alarm Limit Command

**Description: Downloads Low alarm limit value into the addressed module: EEPROM**

**Command: @AALO(data)(cr)**

@ delimiter character

AA module address, (range 00-FF) hexadecimal

LO is set low-alarm command

(data) is low-alarm value,data formats is Engineering Units(plus (+) or minus (-) sign, followed by five decimal digits and a decimal point.)

(cr) terminating character, carriage return (0Dh)

**Response:!AA (cr)** command is valid

?AA(cr) command is invalid or nonlicet operation

! delimiter character, indicates a valid command

? delimiter character, indicates a valid command

AA is input module address

(cr) terminating character, carriage return (0Dh)

There is no response if the module detects a syntax or communication error, or even if the specified address does not exist.

**Example: command @15LO+0200.0 (cr)**

**Response !15 (cr)**

Module Type J thermocouple input low-alarm is 200°C at adress 15H

**19、 Read High Alarm Command****Description:** Read a analog input module high-alarm limit value**Command:** @AARH(cr)

@ delimiter character  
 AA module address, (range 00-FF) hexadecimal  
 RH represents read high-alarm command  
 (cr) terminating character, carriage return (0Dh)

**Response:** ! AA(data) (cr) command is valid

?AA(cr) command is invalid or nonlicet operation  
 ! delimiter character, indicates a valid command  
 ? delimiter character, indicates a invalid command  
 AA is input module address  
 (data) is high-alarm value,data formats is Engineering Units  
 (cr) terminating character, carriage return (0Dh)

There is no response if the module detects a syntax or communication error, or even if the specified address does not exist.

**Example:** command @12RH (cr)  
 Response !12+0700.0 (cr)

Module Type J thermocouple input high-alarm is 700°C at adress 12H

**20、 Read Low Alarm Command****Description:**Read a analog input module low-alarm limit value**Command:** @AARL(cr)

@ delimiter character  
 AA module address, (range 00-FF) hexadecimal  
 RL represents read low-alarm command  
 (cr) terminating character, carriage return (0Dh)

**Response:** ! AA(data) (cr) command is valid

?AA(cr) command is invalid or nonlicet operation  
 ! delimiter character, indicates a valid command  
 ? delimiter character, indicates a invalid command  
 AA is input module address  
 (data) is low-alarm value,data formats is Engineering Units  
 (cr) terminating character, carriage return (0Dh)

There is no response if the module detects a syntax or communication error, or even if the specified address does not exist.

**Example:** command @12RL (cr)  
 Response !12+0200.0 (cr)

Module Type J thermocouple input low-alarm is 200°C at adress 12H

**Input Ranges& Data Formats**

Analog Input four data formats: 00: Engineering Units  
 01: % of FSR  
 10: Twos complement hexadecimal  
 11: ohms

Code	Input Range	Data Formats	+F.S.	ZERO	-F.S	Displayed Resolution
00	±15mV	Engineering Units	+15.000	±00.000	-15.000	1uV
		% of FSR	+100.00	±000.00	-100.00	0.01%
		Twos complement hexadecimal	7FFFFFFF	000000	800000	1LSB
01	±50mV	Engineering Units	+50.000	±00.000	-50.000	1uV
		% of FSR	+100.00	±000.00	-100.00	0.01%
		Twos complement hexadecimal	7FFFFFFF	000000	800000	1LSB
02	±100mV	Engineering Units	+100.00	±000.00	-100.00	10uV
		% of FSR	+100.00	±000.00	-100.00	0.01%
		Twos complement hexadecimal	7FFFFFFF	000000	800000	1LSB
03	±500mV	Engineering Units	+500.00	±000.00	-500.00	10uV
		% of FSR	+100.00	±000.00	-100.00	0.01%
		Twos complement hexadecimal	7FFFFFFF	000000	800000	1LSB
04	±1V	Engineering Units	+1.0000	±00.000	-1.0000	100uV
		% of FSR	+100.00	±000.00	-100.00	0.01%
		Twos complement hexadecimal	7FFFFFFF	000000	800000	1LSB
05	±2.5 V	Engineering Units	+2.5000	±0.0000	-2.5000	100uV
		% of FSR	+100.00	±000.00	-100.00	0.01%
		Twos complement hexadecimal	7FFFFFFF	000000	800000	1LSB
06	±20mA	Engineering Units	+20.000	±00.000	-20.000	1uA
		% of FSR	+100.00	±000.00	-100.00	0.01%
		Twos complement hexadecimal	7FFFFFFF	000000	800000	1LSB

Code	Thermocouple Input Range	Data Formats	Max.	Min.	Displayed Resolution
0E	J(0°C~760°C)	Engineering Units	+760.00	+000.00	0.01°C
		% of FSR	+100.00	+000.00	0.01%
		Twos complement hexadecimal	7FFFFFFF	000000	1LSB
0F	K(0°C~1000°C)	Engineering Units	+1000.0	+0000.0	0.1°C
		% of FSR	+100.00	+000.00	0.01%
		Twos complement hexadecimal	7FFFFFFF	000000	1LSB
10	T(-100°C~400°C)	Engineering Units	+400.00	-100.00	0.01°C
		% of FSR	+100.00	-025.00	0.01%
		Twos complement hexadecimal	7FFFFFFF	DFFFFFFF	1LSB
11	E(0°C~1000°C)	Engineering Units	+1000.0	+0000.0	0.1°C
		% of FSR	+100.00	+000.00	0.01%
		Twos complement hexadecimal	7FFFFFFF	000000	1LSB
12	R(500°C~1750°C)	Engineering Units	+1750.0	+0500.0	0.1°C
		% of FSR	+100.00	+028.57	0.01%
		Twos complement hexadecimal	7FFFFFFF	24924A	1LSB
13	S(500°C~1750°C)	Engineering Units	+1750.0	+0500.0	0.1°C
		% of FSR	+100.00	+028.57	0.01%
		Twos complement hexadecimal	7FFFFFFF	24924A	1LSB
14	B(500°C~1800°C)	Engineering Units	+1800.0	+0500.0	0.1°C
		% of FSR	+100.00	+027.77	0.01%
		Twos complement hexadecimal	7FFFFFFF	238E39	1LSB

**Example:**

1、 Input Range:±20mA,Output:4 mA

	<b>command</b>	<b>#01(cr)</b>
Engineering Units	<b>Response</b>	<b>&gt;+04.000(cr)</b>
Percent of FSR	<b>Response</b>	<b>&gt;+020.00(cr)</b>
Twos complement hexadecimal	<b>Response</b>	<b>&gt;199999(cr)</b>

2、 Input Range:K Type Thermocouple(0°C ~1000°C),Output:600°C

	<b>command</b>	<b>#01(cr)</b>
Engineering Units	<b>Response</b>	<b>&gt;+0600.0(cr)</b>
Percent of FSR	<b>Response</b>	<b>&gt;+060.00(cr)</b>
Twos complement hexadecimal	<b>Response</b>	<b>&gt;4CCCC(cr)</b>

**Module Calibration**

In order to improve calibration precision,suggest to do as the following meters:

- 1、 Stable output,low noise DC voltage/current signal source
- 2、 High precision meter

**Calibration Process:**

1. Choose right input range,different input ranges need different calibration voltage
2. Connect right offset voltage to analoge input,thermocouple signal calibration voltage value,refer to Table 5-1
3. Send out offset calibration \$AA1 command to analog input module,after signal stable
4. Connect right gain voltage to analoge input module,thermocouple signal calibration voltage value,refer to Table 5-1
5. Send out offset calibration \$AA0 commandto analog input module,after signal stable
6. Finished

**Thermocouple signal calibration voltage**

Code	Thermocouple Input Range	Offset Calibration Voltage	Gain Calibration Voltage
0E	J(0°C ~760°C)	0mV	+50mV
0F	K(0°C ~1000°C)	0mV	+45mV
10	T(-100°C ~400°C)	0mV	+25mV
11	E(0°C ~1000°C)	0mV	+78mV
12	R(500°C ~1750°C)	0mV	+22mV
13	S(500°C ~1750°C)	0mV	+20mV
14	B(500°C ~1800°C)	0mV	+15mV

**Table 5-1**