

**SCHOTTKY BARRIER RECTIFIER**

**VOLTAGE RANGE 20 to 60 Volts CURRENT 10 Amperes**

**FEATURES**

- \* Low switching noise
- \* Low forward voltage drop
- \* Low thermal resistance
- \* High current capability
- \* High switching capability
- \* High surge capability
- \* High reliability

**MECHANICAL DATA**

- \* Case: ITO-220 molded plastic
- \* Epoxy: Device has UL flammability classification 94V-O
- \* Lead: MIL-STD-202E method 208C guaranteed
- \* Mounting position: Any
- \* Weight: 2.24 grams

**MAXIMUM RATINGS AND ELECTRICAL CHARACTERISTICS**

Ratings at 25 °C ambient temperature unless otherwise specified.  
Single phase, half wave, 60 Hz, resistive or inductive load.  
For capacitive load, derate current by 20%.

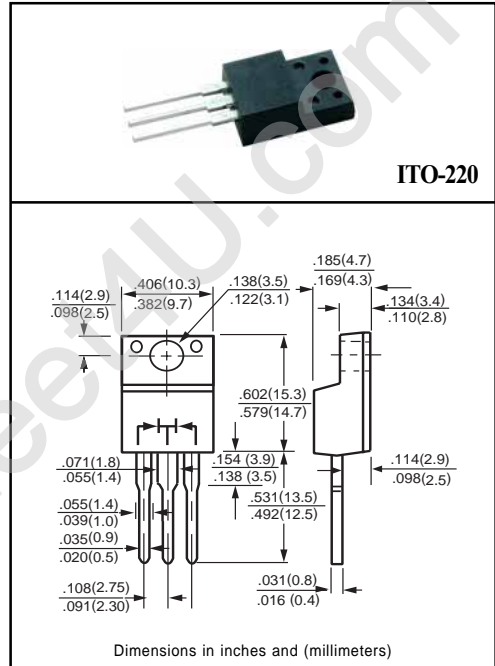

**MAXIMUM RATINGS** (At TA = 25°C unless otherwise noted)

RATINGS		SYMBOL	ISR1020C	ISR1030C	ISR1035C	ISR1040C	ISR1045C	ISR1050C	ISR1060C	UNITS	
Maximum Recurrent Peak Reverse Voltage		VRRM	20	30	35	40	45	50	60	Volts	
Maximum RMS Voltage		VRMS	14	21	25	28	32	35	42	Volts	
Maximum DC Blocking Voltage		VDC	20	30	35	40	45	50	60	Volts	
Maximum Average Forward Rectified Current at Derating Case Temperature		IO	10								Amps
Peak Forward Surge Current 8.3 ms single half sine-wave superimposed on rated load (JEDEC method)		IFSM	150								Amps
Typical Thermal Resistance (Note 1)		RθJC	3								°C/W
Typical Junction Capacitance (Note 3)		CJ	700				500				pF
Operating Temperature Range		TJ	-55 to + 150								°C
Storage Temperature Range		TSTG	-55 to + 150								°C

**ELECTRICAL CHARACTERISTICS** (At TA = 25°C unless otherwise noted)

CHARACTERISTICS		SYMBOL	ISR1020C	ISR1030C	ISR1035C	ISR1040C	ISR1045C	ISR1050C	ISR1060C	UNITS	
Maximum Instantaneous Forward Voltage at 8.0A DC		VF	.65				.75				Volts
Maximum Average Reverse Current at Rated DC Blocking Voltage	@ Tc = 25°C	IR	10								mAmps
	@ Tc = 100°C		100								mAmps

- NOTES : 1. Thermal Resistance Junction to Case.  
2. Suffix "A" = Common Anode.  
3. Measured at 1 MHz and applied reverse voltage of 4.0 volts.

# RATING AND CHARACTERISTIC CURVES ( ISR1020C THRU ISR1060C )

FIG. 1 - TYPICAL FORWARD CURRENT DERATING CURVE

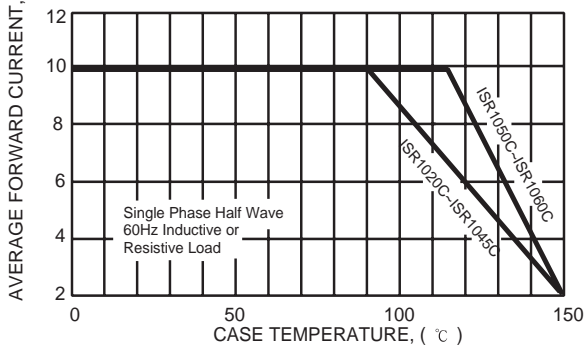

FIG. 2 - TYPICAL REVERSE CHARACTERISTICS

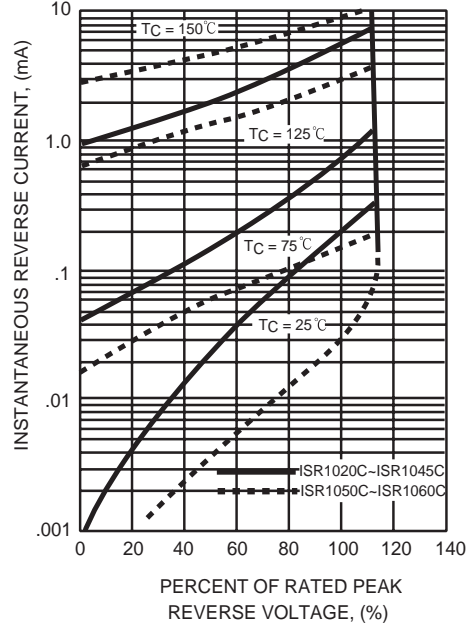

FIG. 3 - MAXIMUM NON-REPETITIVE FORWARD SURGE CURRENT

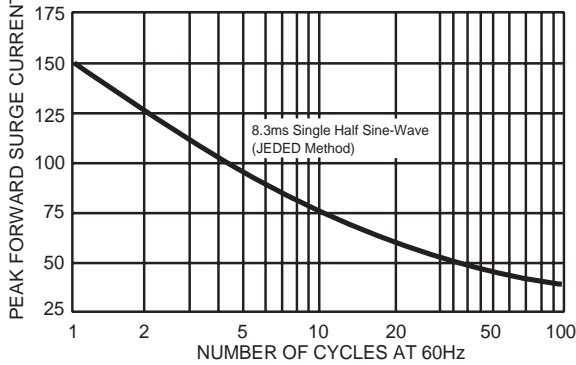

FIG. 4 - TYPICAL JUNCTION CAPACITANCE

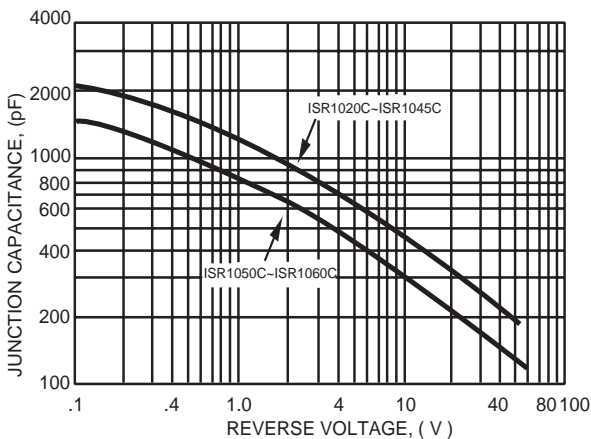

FIG. 5 - TYPICAL INSTANTANEOUS FORWARD CHARACTERISTICS

