

# **IT7652**

**2A/18V High Efficiency Synchronous Rectified  
Step-Down DC/DC Converter**

**Preliminary Specification V0.1.2**

**ITE TECH. INC.**

*This specification is subject to Change without notice. It is provided "AS IS" and for reference only. For purchasing information, please contact the nearest ITE TECH sales representatives.*

Copyright © 2010 ITE Tech. Inc.

**Confidentiality Statement:**

This Data Sheet (including any attachments) is for the sole use of the intended recipient(s) and contains confidential, proprietary and privileged information. Any unauthorized review, use, disclosure or distribution is prohibited. If you are not the intended recipient, please immediately destroy all copies of the original message.

This is a Preliminary document release. All specifications are subject to change without notice. The material contained in this document supersedes all previous material issued for the products herein referenced. Please contact ITE Tech. Inc. for the latest document(s).

All sales are subject to ITE's Standard Terms and Conditions, a copy of which is included in the back of this document.

ITE, IT7652M is a trademark of ITE Tech. Inc.  
All other trademarks are claimed by their respective owners.  
All specifications are subject to change without notice.

Additional copies of this manual or other ITE literature may be obtained from:

ITE Tech. Inc.	Tel:	886-2-29126889
Marketing Department	Fax:	886-2-2910-2551, 886-2-2910-2552
7F, No.233-1, Baociao Rd., Sindian City, Taipei County 23145, Taiwan, ROC		

You may also find the local sales representative nearest you on the ITE web site.

To find out more about ITE, visit our World Wide Web at:  
<http://www.ite.com.tw>

Or e-mail [itesupport@ite.com.tw](mailto:itesupport@ite.com.tw) for more product information/services

**Revision History**

Revision
<ul style="list-style-type: none"><li>Modified the format in accordance with ITE's.</li></ul>



## General Description

The IT7652 is a high efficiency synchronous step-down DC/DC converter series with 1.5A continuous output current supplied and peak current up to 2A. Included on the substrate with the features listed is a high performance trans-conductance error amplifier that provides tight voltage regulation and accuracy under transient conditions. A built-in under voltage lockout circuit is provided to prevent start-up until the input voltage reaches to 4.5V. In addition, it features over-current protection and thermal shutdown. The IT7652 is available in SOP8 package.

## Application

- Data comm. xDSL CPE Graphics Cards
- Set-Top-Box, DVD
- Servers/Networking
- DSP and FPGA Power Supply
- Telecomm Equipments
- DC-DC Regulator Modules
- LCD Monitor and LCD TV

## Pin Configuration

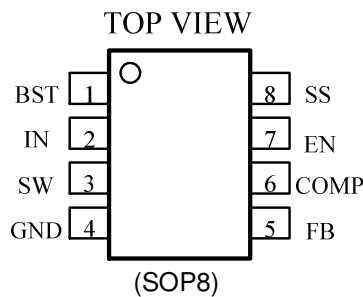

## Features

- Input Voltage Supply Range from 4.5V to 18V
- High Efficiency up to 92%
- Adjustable Output Voltage from 0.92V to 12V
- 1.5A Continuous Output Current; 2A Peak Output Current
- 380kHz Constant Frequency Operation
- Current Mode Operation
- Programmable Soft-start
- Over-temperature Protection
- Over-current Protection
- Input Under Voltage Lockout
- 15  $\mu$  A Shutdown Current
- SOP8 Package
- RoHS Compliant (100% Green Available)

## Ordering Information

Part No.	Package	Shipment
IT7652M	SOP8	2500/Tape & Reel

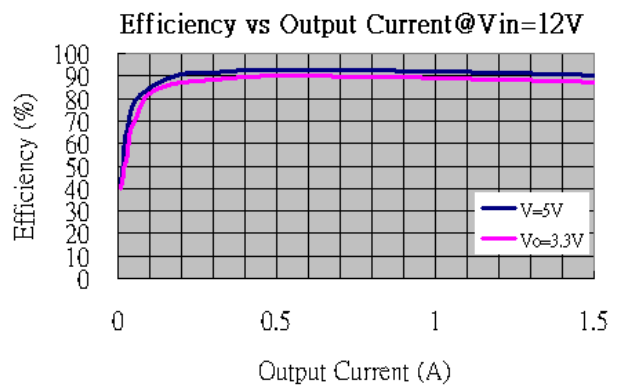

## Typical Application

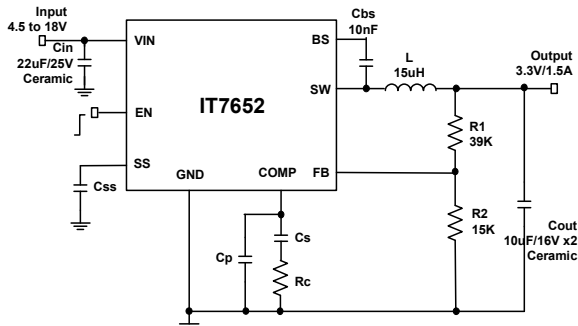

**Block Diagram**

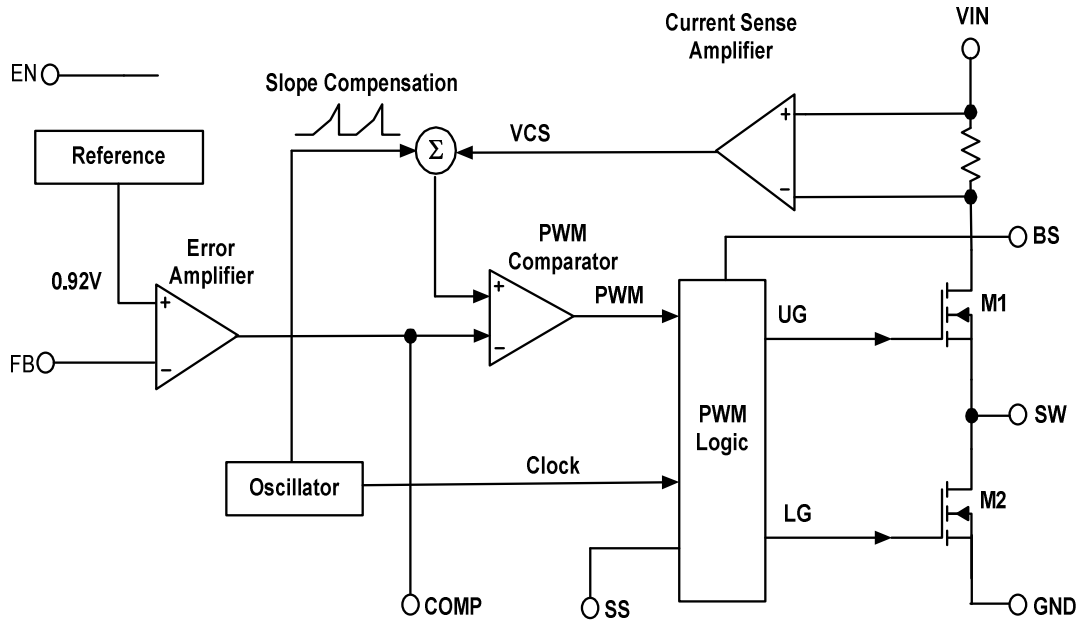

**Pin Description**

Pin(s) No.	Symbol	Description
1	BS	<b>High Side Gate Drive Boost Input</b> It is required to connect SW and BS by a capacitor, which is able to boost the gate drive to the internal NMOS above VIN to fully turn it ON.
2	VIN	<b>Power Supply</b> The input voltage for the power supply is connected to this pin.
3	SW	<b>Power Switch Output</b> This is the output of a power MOSFET switch.
4	GND	<b>Ground</b> This is the reference of the ground connection for all components in the power supply.
5	FB	<b>Voltage Feedback</b> This is the input to an error amplifier, which drives the PWM controller. It is necessary to connect this pin to the actual output of power supply to set the DC output voltage.
6	COMP	<b>Compensation</b> This pin is to compensate the regulation control loop by connecting a series of RC network from COMP pin to GND pin.
7	EN	<b>Enable</b> This input provides an electrical ON/OFF control of the power supply. If the EN pin is open, it will be pulled to high by internal circuit.
8	SS	<b>Soft-start</b> This pin is connected to an external capacitor to control soft-start timing. If it is activated, around 100µS internal soft-start will be used.

**Absolute Maximum Ratings**

Input Supply Voltage.....GND - 0.3V to +21V  
 SW Voltage.....- 1 to VIN+0.3V  
 EN Voltage.....- 0.3 to VIN+0.3V  
 Other Pins.....- 0.3V to +6V  
 Boost Voltage .....Vsw+6V (<24V)  
 ESD Classification.....Class 2  
 Junction Temperature Range..... -40°C to 150°C  
 Storage Temperature Range.....-65°C to 150°C  
 Lead Temperature (Soldering 10s).....260°C

**Recommended Operating Conditions**

Supply Voltage (VIN).....4.5V to 18V  
 Operating Temperature.....-30°C to +85°C

<b>Thermal Resistance</b>	<b>θJA</b>	<b>θJC</b>
SOP8	91	43 °C/W

Note 1: Stresses beyond above listed under absolute maximum ratings may cause permanent damage to the device. These are stress ratings only and functional operation of the device at these or any other conditions beyond those indicated in the operational sections of the specifications are not implied. Exposure to absolute maximum rating conditions for extended periods may remain possibility to affect device reliability.

Note 2: Guaranteed by design, not production tested.

**DC Electrical Characteristics**

(Recommended Operating Conditions, Unless Otherwise Noted; VIN = 12V; TA = 25 °C)

Parameter	Conditions	Min.	Typ.	Max.	Unit
Supply Voltage		4.5		18	V
Shutdown Supply Current	VEN = 0V		15		µA
Regulated Feedback Voltage	4.5V ≤ VIN ≤ 18V		0.92		V
Error Amplifier Transconductance	△ICOMP = ±10µA		830		µA/V
Current Sense to COMP Transconductance			2.2		A/V
Current Limit			2.5		A
SW Leakage Current	VEN = 0V, VSW = 0V			10	µA
High Side On Resistance			0.25		Ω
Low Side On Resistance			0.20		Ω
Oscillation Frequency			380		kHz
Short Circuit Oscillation Frequency	VFB=0V		100		kHz
Maximum Duty Cycle	VFB=0.7V		90		%
Minimum On Time			200		ns
Under Voltage Lockout Threshold	VIN Rising	3.9	4.2	4.3	V
Under Voltage Lockout Threshold Hysteresis			400		mV
Thermal Shutdown Threshold			150		°C
EN High Level			2.5		V
EN Low Level			2.4		V
EN Input Current	VEN = 0V	1.1	1.8	2.5	µA
Soft Start	Pin activated		100		µs

Note: Fully production test at +25°C. Specifications over the temperature range are guaranteed by design and characterization.

## Function Description

The IT7652 is a current mode PWM synchronous step-down converter with a constant switching frequency. It regulates the input voltage from 4.5V to 18V and a low output voltage of 0.92V. The supplied load current is up to 2A.

## Oscillator Frequency

Slope compensated current mode PWM control provides not only stable switching and cycle-by-cycle current limit for superior load and line response but also protection of the internal main switch and synchronous rectifier. The IT7652 switches at a constant frequency (380 kHz) and regulates the output voltage. The PWM comparator modulates the power transferred to the load by changing the inductor's peak current based on the feedback error voltage during each cycle. The main switch is turned on for a certain period to ramp the inductor's current at each rising edge of the internal oscillator under normal operation whereas off when the inductor's peak current is above the error voltage. After the main switch is turned off, the low side MOS will be turned on immediately and stay on until the next cycle starts.

## Short Circuit Protection

The IT7652 provides short circuit protection. When the output is shorted to ground, the oscillator's frequency is reduced to prevent the inductor's current from increasing beyond the NMOS current limit. The NMOS current limit is also reduced to lower the short circuit current. The frequency and current limit will return to the normal values once the short circuit condition is removed and the feedback voltage reaches 0.92V.

## Maximum Load current

The IT7652 can operate down to 4.5V input voltage; however the maximum load current decreases at lower input due to large IR voltage drop on the main switch and low side switch. The slope compensation signal reduces the inductor's peak current as a function of the duty cycle to prevent sub-harmonic oscillations at duty cycles greater than 50%.

## Enable

The EN pin provides electrical on/off control of the regulator. Once the voltage of the EN pin exceeds

the threshold voltage, the regulator starts operation and the internal slow start begins to ramp. If the voltage of the EN pin is pulled below the threshold, the regulator will stop switching and the internal slow start reset. If the EN pin is open, it will be pulled to high by internal circuit.

## Under Voltage Lockout

The IT7652 incorporates an under voltage lockout circuit to keep the device disabled when VIN is below the UVLO start threshold. During power-up, the internal circuit is held inactive until VIN exceeds the UVLO start threshold voltage. Once this threshold voltage is reached, device start-up begins. The device operates until VIN falls below the UVLO stop threshold voltage. The typical hysteresis in the UVLO comparator is 400mV.

## Soft-start

The built-in soft-start function is provided by IT7652 to reduce the input inrush current after power-on. If the SS pin is activated, it will provide about 100μs to make the duty transferred from small to specific duty during the power-on period. Thus this function can lower the current stress on input power, MOSFET, and freewheeling diode. The soft start time can be programmed by connecting this pin with a capacitor, which is defined as the following.

$$T_{SS} = \frac{C_{SS} \times V_{ref}}{I_{SS}}$$

## Boost Capacitor

The BS pin and SW pin can be connected by a 10nF low ESR ceramic capacitor, providing the gate drive voltage for the high side MOSFET.

## Thermal Shutdown

The IT7652 protects itself from overheating with an internal thermal shutdown circuit. If the junction temperature exceeds the thermal shutdown threshold, the voltage reference will be grounded and high side MOSFET turned off.

## Compensation

The system stability is controlled through COMP pin. It will present a general design procedure to ensure a stable and operational circuit. The design in this data sheet is optimized for particular requirements. Some components may need to be changed to ensure



stability if there are different requirements. First of all, the power components and their corresponding effects need to be determined. Following are the compensation components, which are to produce stability.

The compensation steps for the converter are listed below:

- (1). Choose an appropriate inductor and output capacitance based on the allowed output voltage ripple and load transient.
- (2). Place  $F_C$  sufficiently below  $F_S$ . Typically,  $F_C$  is approximately below 1/10 ~ 1/20 of  $F_S$ .
- (3). Set the compensation  $R_C$  to zero to cancel the  $R_{LOAD} C_{OUT}$  pole.

$$R_C = \frac{2\pi \times F_C \times C_{OUT} \times V_{OUT}}{G_M \times G_{CS} \times V_{REF}}$$

$$C_C = \frac{C_{OUT} \times R_{LOAD}}{R_C}$$

$G_M$ : error amp transconductance

$G_{CS}$ : current sense transconductance

- (4). Determine  $C_P$  if required.

If  $Z_{ESR}$  (zero occurs by output capacitor ESR) is less than  $F_C$ , it should be cancelled with a pole set by capacitor  $C_P$  connected between  $C_C$  to GND.

$$C_P = C_{OUT} \times \frac{R_{ESR}}{R_C}$$

## Application Information

### Input Capacitor Selection

It is necessary for the input capacitor to sustain the ripple current produced during the period of "on" state of the upper MOSFET, so a low ESR is required to minimize the loss. The RMS value of this ripple can be obtained by the following:

$$I_{IN\ RMS} = I_{OUT} \sqrt{D \times (1 - D)}$$

where  $D$  is the duty cycle,  $I_{inRMS}$  is the input RMS

current, and  $I_{OUT}$  is the load current. The equation reaches its maximum value with  $D = 0.5$ . The loss of the input capacitor can be calculated by the following equation:

$$P_{CIN} = ESR_{CIN} \times I_{IN\ RMS}^2$$

where  $P_{CIN}$  is the power loss of the input capacitor and  $ESR_{CIN}$  is the effective series resistance of the input capacitance. Due to large  $di/dt$  through the input capacitor, electrolytic or ceramics should be used. If a tantalum must be used, it must be surge-protected. Otherwise, capacitor failure could occur.

### Output Inductor Selection

The output inductor selection is to meet the requirements of the output voltage ripple and affects the load transient response. The higher inductance can reduce the inductor's ripple current and induce the lower output ripple voltage. The ripple voltage and current can be approximately calculated approximated by the following equations:

$$\Delta I = \frac{V_{in} - V_{out}}{F_s \times L} \bullet \frac{V_{out}}{V_{in}}$$

$$\Delta V_{out} = \Delta I \times ESR$$

Although the increase of the inductance reduces the ripple current and voltage, it contributes to the decrease of the response time for the regulator to load transient as well. Increasing the switching frequency ( $F_s$ ) for a given inductor also can reduce the ripple current and voltage but it will increase the switching loss of the power MOS.

The way to set a proper inductor value is to have the ripple current ( $\Delta I$ ) be approximately 10%~50% of the maximum output current. Once the value has been determined, select an inductor capable of carrying the required peak current without going into saturation. It is also important to have the inductance tolerance specified to keep the accuracy of the system controlled. Using 20% for the inductance (at room temperature) is reasonable tolerance able to be met by most manufacturers. For some types of inductors, especially those with core made of ferrite, the ripple current will increase abruptly when it saturates, resulting in a larger output ripple voltage.

**Output Capacitors Selection**

An output capacitor is required to filter the output and supply the load transient current. The high capacitor value and low ESR will reduce the output ripple and the load transient drop. These requirements can be met by a mix of capacitors and careful layout.

In typical switching regulator design, the ESR of the output capacitor bank dominates the transient response. The number of output capacitors can be determined by the following equations:

$$ESR_{MAX} = \frac{\Delta V_{ESR}}{\Delta I_{OUT}}$$

$$\text{Number Of Capacitors} = \frac{ESR_{CAP}}{ESR_{MAX}}$$

- △V<sub>ESR</sub> = change in output voltage due to ESR (assigned by the designer)
- △I<sub>OUT</sub> = load transient.
- ESR<sub>CAP</sub> = maximum ESR per capacitor (specified in manufacturer's data sheet).
- ESR<sub>MAX</sub> = maximum allowable ESR.

High frequency decoupling capacitors should be placed as close to the power pins of the load as physically possible. For the decoupling requirements, please consult the capacitor manufacturers for confirmation.

**Output Voltage**

The output voltage is set using the FB pin and a resistor divider connected to the output as shown in the following AP Circuit. The output voltage (V<sub>out</sub>) can be calculated according to the voltage of the FB pin (V<sub>FB</sub>) and ratio of the feedback resistors by the following equation, where (V<sub>FB</sub>) is 0.92:

$$V_{FB} = V_{out} \times \frac{R_2}{(R_1 + R_2)}$$

Thus the output voltage is:

$$V_{out} = 0.92 \times \frac{(R_1 + R_2)}{R_2}$$

**External Bootstrap Diode**

It is strongly recommended that an external

bootstrap diode be added when there is a 5V fixed input for the system or the power supply generates a 5V output in order to improve the efficiency of the IT7652 regulator. The boost diode can be the one with lost cost such as IN4148 or BAT54.

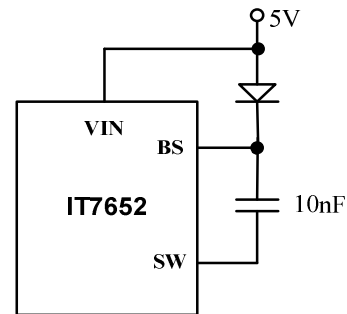

This diode is also recommended for high duty cycle operation when Duty Cycle>65% (Example: VIN=5V & Vout=3.3V; Duty Cycle=66%) and high output voltage (VOUT>12V) applications.

**Layout Consideration**

For proper operation of the converter, some layout rules should be followed. It is necessary to understand which pin of IT7652 is sensitive and which is insensitive. Please refer the following for the location where noise comes from on the circuit and where the clear ground is for the small signal ground.

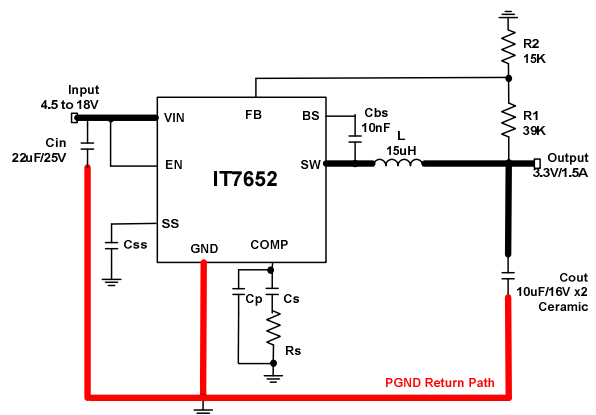

- 1.) First, put the input capacitor (C<sub>IN</sub>) as close as possible to the VIN pin.
- 2.) Secondly, place the Cs, Rs, Cp, C<sub>SS</sub> and R2 as

close as IT7652 and connect these analog grounds (Clear AGND) to IT7652's GND pin. It is recommended to use a dot short for these AGND pins or connect the GND pin via contact.

- 3.) The large current loop shown in bold lines in the above figure circuit should be routed as short and wide as possible and the switch node is a high dv/dt. It easily couples noise to other traces by the capacitive path. Therefore the sensitive signals like FB, COMP and AGND should be routed away with this noise source.
  
- 4.) The feedback network resistors (R1 & R2)

should be routed away from the inductor and switch node to minimize noise and EMI issue. And the R1 resistor should be sensed the output capacitor or device loading, not the inductor's output node.

**Top Layer**

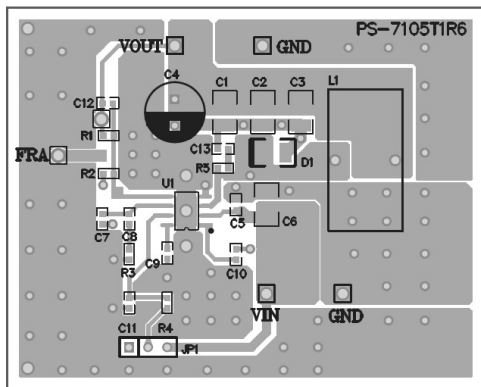

**Bottom Layer (Top view)**

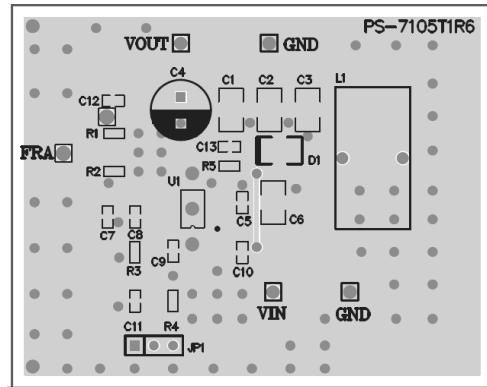

## IT7652 EVB Schematic

### Application 1

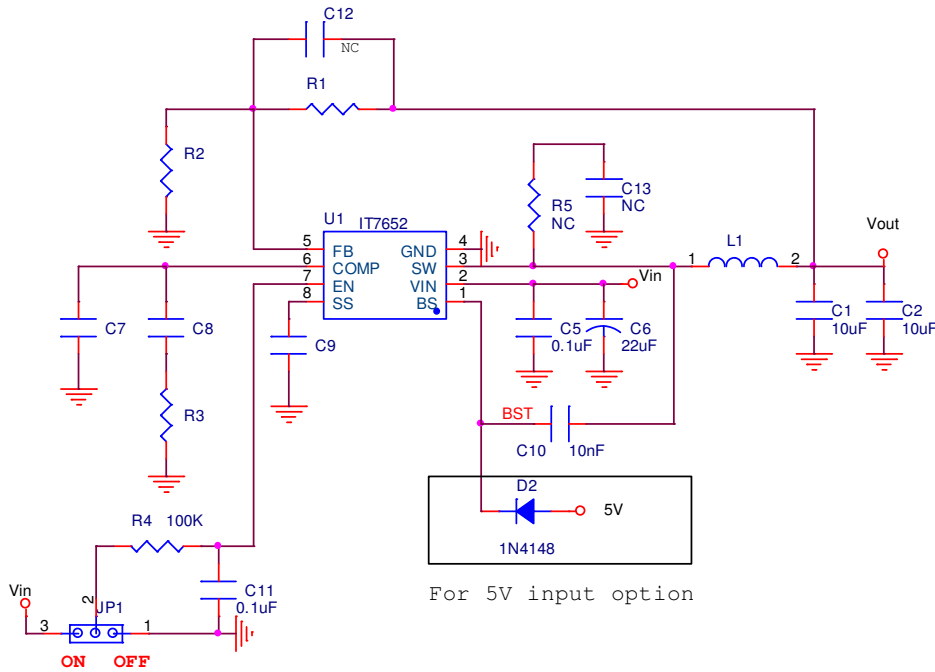

### Application 2

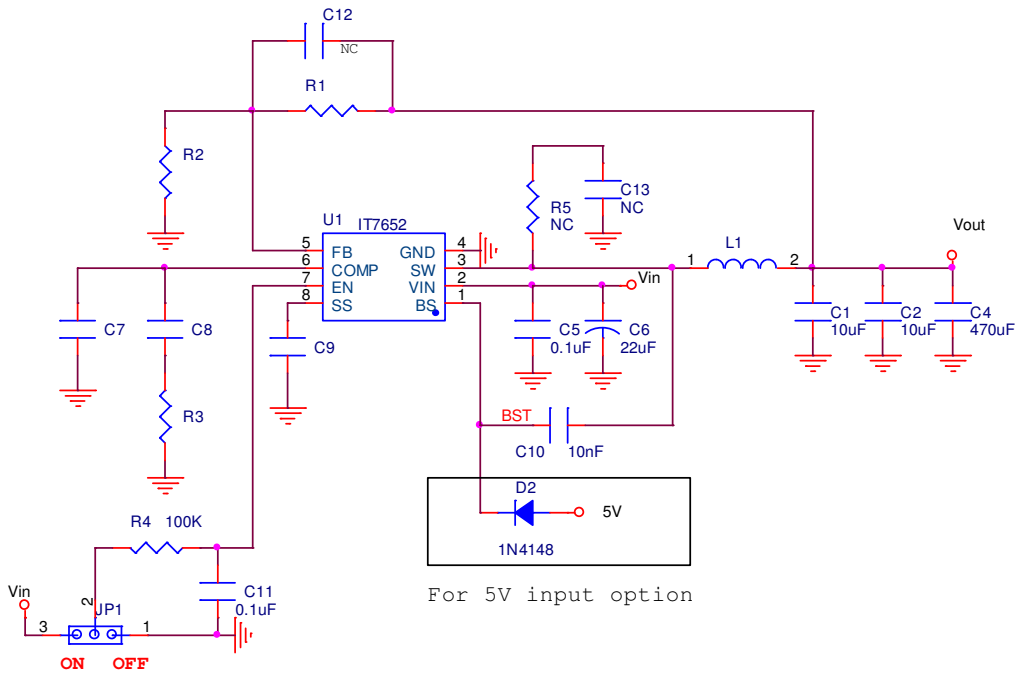

## Application 1 EVB BOM List

Qty	Ref	Value		Description	Package
2	C1, C2,	10 $\mu$ F		Ceramic Capacitor	1206
1	C6	22 $\mu$ F		Ceramic Capacitor	1206
3	C5,C11	0.1 $\mu$ F		Ceramic Capacitor	0603
1	L1	15 $\mu$ H		Inductor, Rated Current 3A	SMD
1	R4	100K $\Omega$		Resistor, $\pm$ 1%	0603
1	R1	Vout=5V	68 K $\Omega$	Resistor, $\pm$ 1%	0603
		Vout=3.3V	39 K $\Omega$		
		Vout=1.8V	15 K $\Omega$		
		Vout=1V	820 $\Omega$		
1	R2	Vout=5V	15 K $\Omega$	Resistor, $\pm$ 1%	0603
		Vout=3.3V	15 K $\Omega$		
		Vout=1.8V	15.4 K $\Omega$		
		Vout=1V	10 K $\Omega$		
1	R3	Vout=5V	4.7 K $\Omega$	Resistor, $\pm$ 1%	0603
		Vout=3.3V	3 K $\Omega$		
		Vout=1.8V	2.2 K $\Omega$		
		Vout=1V	1.2 K $\Omega$		
1	C10	10nF		Ceramic Capacitor	0603
1	C7	Vout=5V	NC	Ceramic Capacitor	0603
		Vout=3.3V	NC		
		Vout=1.8V	NC		
		Vout=1V	NC		
1	C8	Vout=5V	4.7 nF	Ceramic Capacitor	0603
		Vout=3.3V	8.2 nF		
		Vout=1.8V	15 nF		
		Vout=1V	47 nF		
1	C12,C13,R5	NC			
1	U1	IT7652M		Step-Down DC/DC Converter	SOP8-EP

## Application 2 EVB BOM List

Qty	Ref	Value		Description	Package
2	C1, C2,	10 $\mu$ F		Ceramic Capacitor	1206
1	C6	22 $\mu$ F		Ceramic Capacitor	1206
1	C4	470 $\mu$ F		Electrolytic Capacitor	6.3X11
3	C5,C11	0.1 $\mu$ F		Ceramic Capacitor	0603
1	L1	15 $\mu$ H		Inductor, Rated Current 3A	SMD
1	R4	100K $\Omega$		Resistor, $\pm$ 1%	0603
1	R1	Vout=5V	68 K $\Omega$	Resistor, $\pm$ 1%	0603
		Vout=3.3V	39 K $\Omega$		
		Vout=1.8V	15 K $\Omega$		
		Vout=1V	820 $\Omega$		
1	R2	Vout=5V	15 K $\Omega$	Resistor, $\pm$ 1%	0603
		Vout=3.3V	15 K $\Omega$		
		Vout=1.8V	15.4 K $\Omega$		
		Vout=1V	10 K $\Omega$		
1	R3	Vout=5V	300 K $\Omega$	Resistor, $\pm$ 1%	0603
		Vout=3.3V	180 K $\Omega$		
		Vout=1.8V	100 K $\Omega$		
		Vout=1V	51 K $\Omega$		
1	C10	10nF		Ceramic Capacitor	0603
1	C7	Vout=5V	390 pF	Ceramic Capacitor	0603
		Vout=3.3V	560 pF		
		Vout=1.8V	2200 pF		
		Vout=1V	1820 pF		
1	C8	Vout=5V	4.7 nF	Ceramic Capacitor	0603
		Vout=3.3V	4.7 nF		
		Vout=1.8V	10 nF		
		Vout=1V	4.7 nF		
1	C12,C13,R5	NC			
1	U1	IT7652M		Step-Down DC/DC Converter	SOP8-EP

Package Information

SOP8 Outline Dimensions

unit: inches/mm

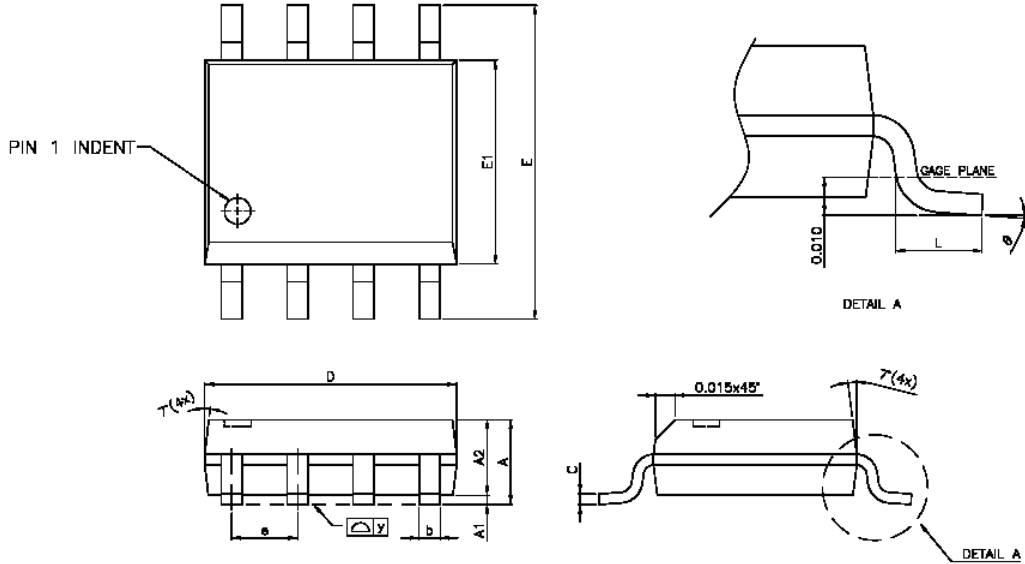

Symbol	Dimension in inches			Dimension in mm		
	Min	Nom	Max	Min	Nom	Max
A	0.058	0.063	0.068	1.47	1.60	1.73
A <sub>1</sub>	0.004	—	0.010	0.10	—	0.25
A <sub>2</sub>	—	0.057	—	—	1.45	—
b	0.013	0.016	0.020	0.33	0.41	0.51
C	0.0075	0.008	0.0098	0.19	0.20	0.25
D	0.189	0.191	0.195	4.80	4.85	4.95
E	0.228	0.236	0.244	5.80	6.00	6.20
E <sub>1</sub>	0.150	0.154	0.157	3.80	3.90	4.00
e	—	0.050	—	—	1.27	—
L	0.015	0.028	0.050	0.38	0.71	1.27
y	—	—	0.004	—	—	0.1
θ	0°	—	8°	0°	—	8°

Notes:

1. Controlling dimension : INCH
2. Dimension "D" does not include mold flash, Tie bar burrs and gate burrs.
3. Dimension "b" does not include dambar protrusion.
4. Reference document : JEDEC SPEC MS-012

DI-SOP8(150mil Body)v0

IR Re-flow Profiles

Reflow Profile	Green Assembly
Average Ramp-Up Rate ( $T_{s_{max}}$ to $T_p$ )	3°C/second max.
Preheat -Temperature -Temperature -Time( $t_{s_{min}}$ to $t_{s_{max}}$ )	Min( $T_{s_{min}}$ ) 200°C Max( $T_{s_{max}}$ ) 60-120 seconds
Time maintained above: -Temperature( $T_L$ ) -Time( $t_L$ )	217°C 60-150 seconds
Peak Temperature( $T_p$ )	260 +0/-5 °C
Time within 5 °C of actual Peak Temperature( $t_p$ )	10-30 seconds
Ramp-Down Rate	6°C/second max.
Time 25°C to Peak Temperature	8 minutes max.

**Note:** For all temperature information, please refer to topside of the package, measured on the package body surface.

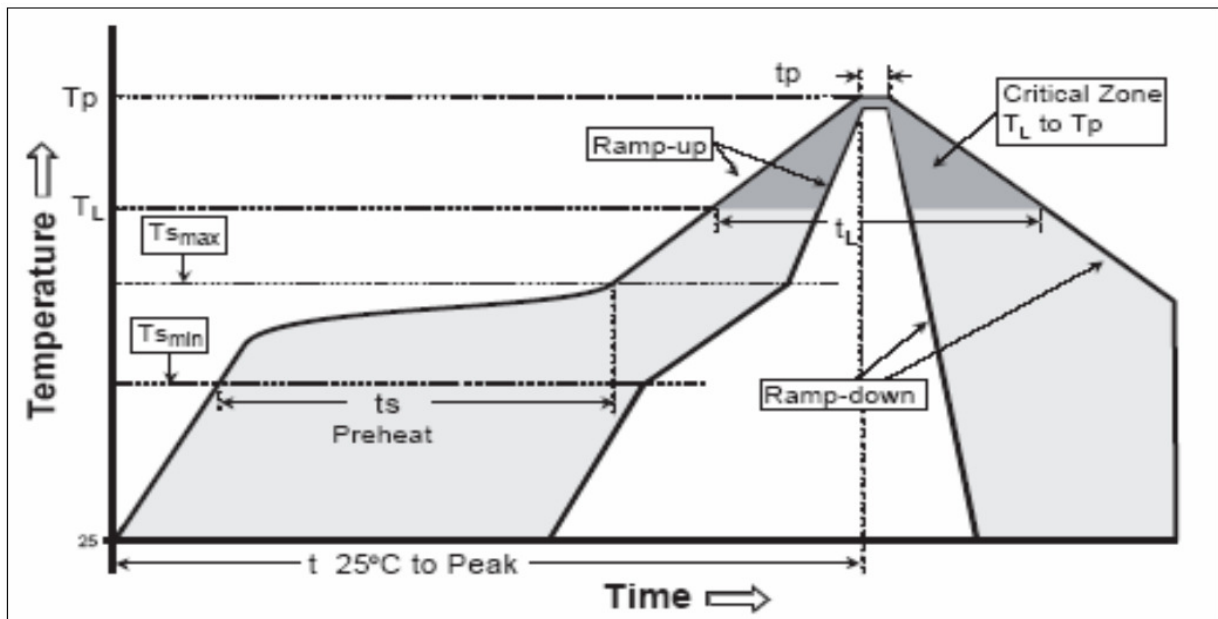



Tape & Reel Carrier Dimensions

SOP8 Package

Carrier Tape

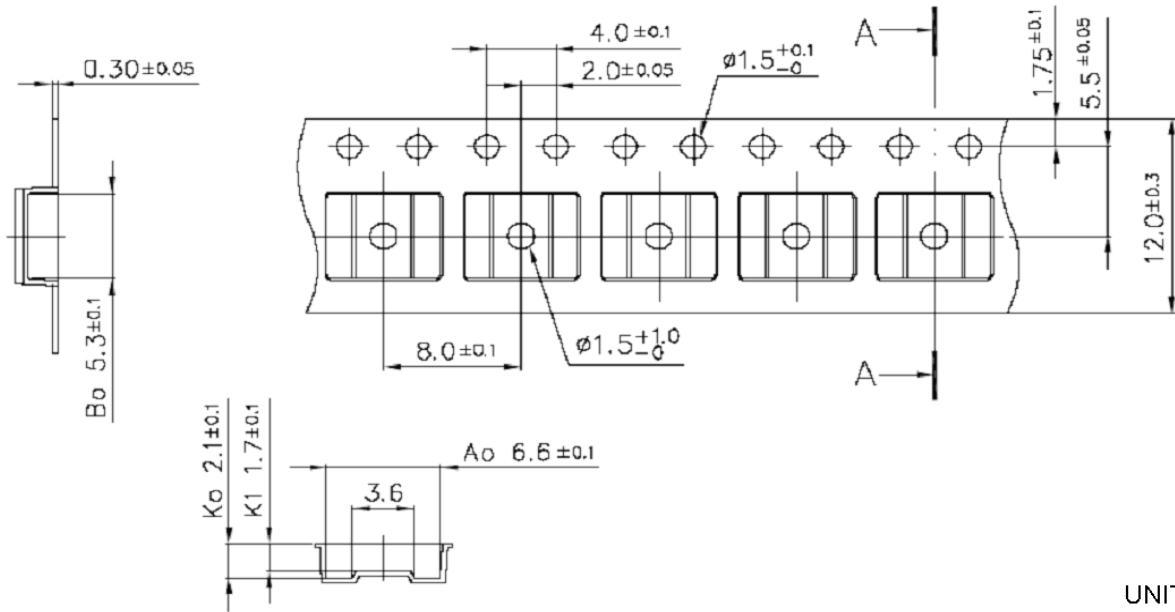

UNIT: mm.

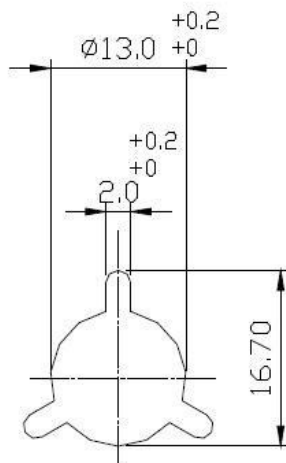
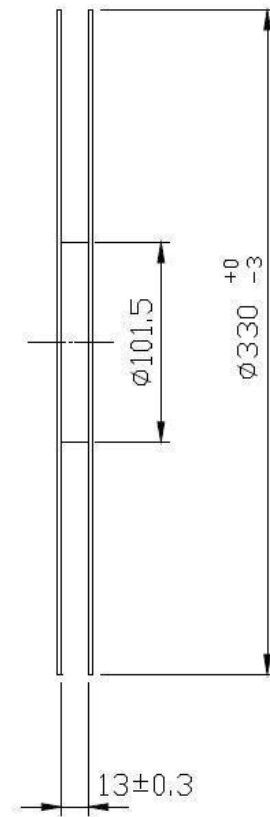
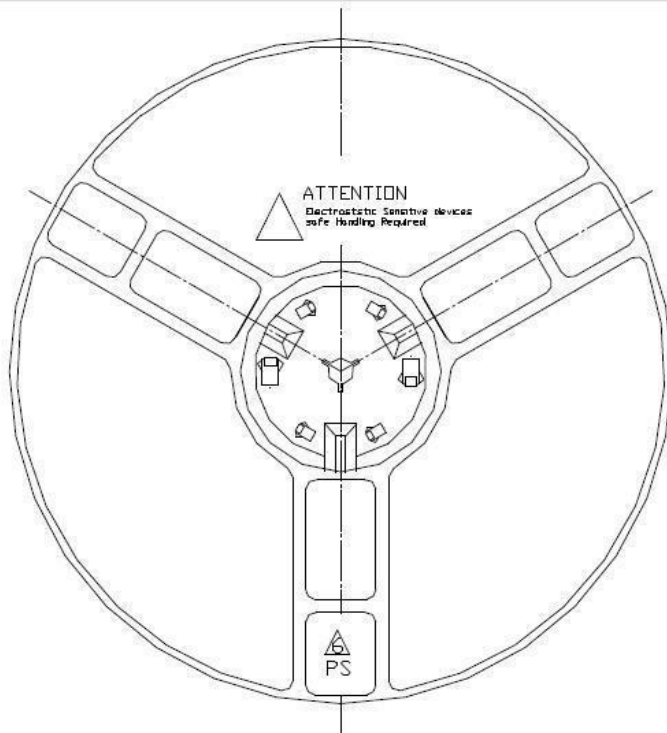

DETAIL "A"  
SCALE 2:1

13" Reel  
W=12 mm

MATERIAL:

PS  
Anti-static

## Top Marking Information

SOP8 Package

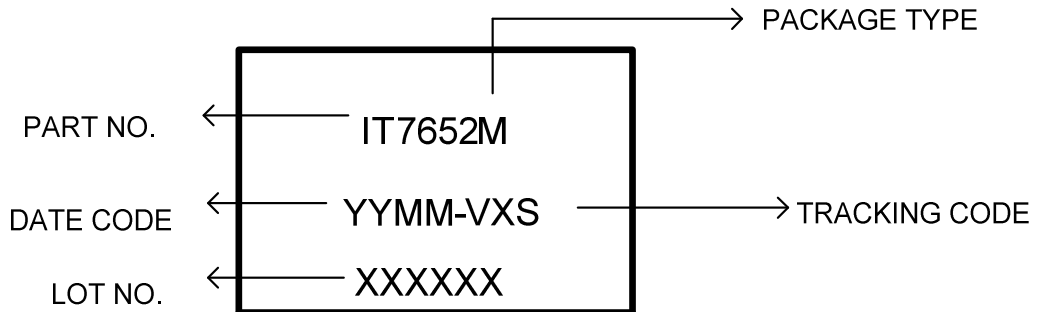

YYMM: Datecode

YY: Year

MM: Week

Year	Code
2008	08
2009	09
2010	10
...	...

## ITE TECH. INC. TERMS AND CONDITIONS OF SALE (Rev: 2005)

### 0. PARTIES

ITE Tech. Inc. ("Seller") is a company headquartered in Taiwan, Republic of China, and incorporated under laws of Republic of China, Buyer is a company or an entity, purchasing product from ITE Tech. Inc..

### 1. ACCEPTANCE OF TERMS

BUYER ACCEPTS THESE TERMS (i) BY WRITTEN ACCEPTANCE (BY PURCHASE ORDER OR OTHERWISE), OR (ii) BY FAILURE TO RETURN GOODS DESCRIBED ON THE FACE OF THE PACKING LIST WITHIN FIVE DAYS OF THEIR DELIVERY.

### 2. DELIVERY

- Delivery will be made Free Carrier (Incoterms), Seller's warehouse, Science-Based Industrial Park, Hsinchu, Taiwan.
- Title to the goods and the entire risk will pass to Buyer upon delivery to carrier.
- Shipments are subject to availability. Seller shall make every reasonable effort to meet the date(s) quoted or acknowledged; and if Seller makes such effort, Seller will not be liable for any delays.

### 3. TERMS OF PAYMENT

- Terms are as stated on Seller's quotation, or if none are stated, net thirty (30) days. Accounts past due will incur a monthly charge at the rate of one percent (1%) per month (or, if less, the maximum allowed by applicable law) to cover servicing costs.
- Seller reserves the right to change credit terms at any time in its sole discretion.

### 4. LIMITED WARRANTY

- Seller warrants that the goods sold will be free from defects in material and workmanship and comply with Seller's applicable published specifications for a period of ninety (90) days from the date of Seller's delivery. Within the warranty period and by obtaining a return number from Seller, Buyer may request replacement or repair for defective goods.
- Goods or parts which have been subject to abuse (including without limitation repeated or extended exposure to conditions at or near the limits of applicable absolute ratings) misuse, accident, alteration, neglect, or unauthorized repair or improper application are not covered by any warranty. No warranty is made with respect to custom products or goods produced to Buyer's specifications (unless specifically stated in a writing signed by Seller).
- No warranty is made with respect to goods used in devices intended for use in applications where failure to perform when properly used can reasonably be expected to result in significant injury (including, without limitation, navigation, aviation or nuclear equipment, or for surgical implant or to support or sustain life) and Buyer agrees to indemnify, defend, and hold harmless Seller from all claims, damages and liabilities arising out of any such uses.
- This Paragraph 4 is the only warranty by Seller with respect to goods and may not be modified or amended except in writing signed by an authorized officer of Seller.
- Buyer acknowledges and agrees that it is not relying on any applications, diagrams or circuits contained in any literature, and Buyer will test all parts and applications under extended field and laboratory conditions. Notwithstanding any cross-reference or any statements of compatibility, functionality, interchangeability, and the like, the goods may differ from similar goods from other vendors in performance, function or operation, and in areas not contained in the written specifications, or as to ranges and conditions outside such specifications; and Buyer agrees that there are no warranties and that Seller is not responsible for such things.
- EXCEPT AS PROVIDED ABOVE, SELLER MAKES NO WARRANTIES OR CONDITIONS, EXPRESS, IMPLIED, OR STATUTORY; AND SELLER EXPRESSLY EXCLUDES AND DISCLAIMS ANY WARRANTY OR CONDITION OF MERCHANTABILITY OR FITNESS FOR PARTICULAR PURPOSE OR APPLICATION.

### 5. LIMITATION OF LIABILITY

- Seller will not be liable for any loss, damage or penalty resulting from causes beyond its reasonable control, including but not limited to delay by others, force majeure, acts of God, or labor conditions. In any such event, the date(s) for Seller's performance will be deemed extended for a period equal to any delay resulting.
- THE LIABILITY OF SELLER ARISING OUT OF THE CONTRACT OR ANY GOODS SOLD WILL BE LIMITED TO REFUND OF THE PURCHASE PRICE OR REPLACEMENT OF PURCHASED GOODS (RETURNED TO SELLER FREIGHT PRE-PAID) OR, WITH SELLER'S PRIOR WRITTEN CONSENT, REPAIR OF PURCHASED GOODS.
- Buyer will not return any goods without first obtaining a customer return order number.
- AS A SEPARATE LIMITATION, IN NO EVENT WILL SELLER BE LIABLE FOR COSTS OF SUBSTITUTE GOODS; FOR ANY SPECIAL, CONSEQUENTIAL, INCIDENTAL OR INDIRECT DAMAGES; OR LOSS OF USE, OPPORTUNITY, MARKET POTENTIAL, AND/OR PROFIT ON ANY THEORY (CONTRACT, TORT, FROM THIRD PARTY CLAIMS OR OTHERWISE). THESE LIMITATIONS SHALL APPLY NOTWITHSTANDING ANY FAILURE OF ESSENTIAL PURPOSE OF ANY REMEDY.
- No action against Seller, whether for breach, indemnification, contribution or otherwise, shall be commenced more than one year after the cause of action has accrued, or more than one year after either the Buyer, user or other person knew or with reasonable diligence should have known of the matter or of any claim of dissatisfaction or defect involved; and no such claim may be brought unless Seller has first been given commercially reasonable notice, a full written explanation of all pertinent details, and a good faith opportunity to resolve the matter.
- BUYER EXPRESSLY AGREES TO THE LIMITATIONS OF THIS PARAGRAPH 5 AND TO THEIR REASONABLENESS.

### 6. SUBSTITUTIONS AND MODIFICATIONS

Seller may at any time make substitutions for product ordered which do not materially and adversely affect overall performance with the then current specifications in the typical and intended use. Seller reserves the right to halt deliveries and shipments and alter specifications and prices without notice. Buyer shall verify that the literature and information is current before purchasing.

### 7. CANCELLATION

The purchase contract may not be canceled by Buyer except with written consent by Seller and Buyer's payment of reasonable cancellation charges (including but not be limited to expenses already incurred for labor and material, overhead, commitments made by Seller, and a reasonable profit).

### 8. INDEMNIFICATION

Seller will, at its own expense, assist Buyer with technical support and information in connection with any claim that any parts as shipped by Seller under the purchase order infringe any valid and enforceable copyright, or trademark, provided however, that Buyer (i) gives immediate written notice to Seller, (ii) permits Seller to participate and to defend if Seller requests to do so, and (iii) gives Seller all needed information, assistance and authority. However, Seller will not be responsible for infringements resulting from anything not entirely manufactured by Seller, or from any combination with products, equipment, or materials not furnished by Seller. Seller will have no liability with respect to intellectual property matters arising out of products made to Buyer's specifications, code, or designs.

Except as expressly stated in this Paragraph 8 or in another writing signed by an authorized officer, Seller makes no representations and/or warranties with respect to intellectual and/or industrial property and/or with respect to claims of infringement. Except as to claims Seller agrees in writing to defend, BUYER WILL INDEMNIFY, DEFEND AND HOLD HARMLESS SELLER FROM ALL CLAIMS, COSTS, LOSSES AND DAMAGES (INCLUDING ATTORNEYS FEES) AGAINST AND/OR ARISING OUT OF GOODS SOLD AND/OR SHIPPED HEREUNDER.

### 9. NO CONFIDENTIAL INFORMATION

Seller shall have no obligation to hold any information in confidence except as provided in a separate non-disclosure agreement signed by both parties.

### 10. ENTIRE AGREEMENT

- These terms and conditions are the entire agreement and the only representations and understandings between Seller and Buyer, and no addition, deletion or modification shall be binding on Seller unless expressly agreed to in writing and signed by an officer of Seller.
- Buyer is not relying upon any warranty or representation except for those specifically stated here.

### 11. APPLICABLE LAW

The contract and all performance and disputes arising out of or relating to goods involved will be governed by the laws of R.O.C. (Taiwan, Republic of China), without reference to the U.N. Convention on Contracts for the International Sale of Goods or to conflict of laws principles. Buyer agrees at its sole expense to comply with all applicable laws in connection with the purchase, use or sale of the goods provided hereunder and to indemnify Seller from any failure by Buyer to so comply. Without limiting the foregoing, Buyer certifies that no technical data or direct products thereof will be made available or re-exported, directly or indirectly, to any country to which such export or access is prohibited or restricted under R.O.C. laws or U.S. laws or regulations, unless prior authorization is obtained from the appropriate officials and agencies of the government as required under R.O.C. or U.S. laws or regulations.

### 12. JURISDICTION AND VENUE

The courts located in Hsinchu, Taiwan, Republic of China, will have the sole and exclusive jurisdiction and venue over any dispute arising out of or relating to the contract or any sale of goods hereunder. Buyer hereby consents to the jurisdiction of such courts.

### 13. ATTORNEYS' FEES

Reasonable attorneys' fees and costs will be awarded to the prevailing party in the event of litigation involving and/or relating to the enforcement or interpretation of the contract and/or any goods sold under it.