

N-Channel MOSFET

Lead Free Package and Finish

Applications:

- Adaptor
- Charger
- SMPS

V_{DSS}	$R_{DS(ON)}(Typ.)$	I_D
650V	2.4Ω	4A

Features:

- RoHS Compliant
- Low ON Resistance
- Low Gate Charge
- Peak Current vs Pulse Width Curve
- Inductive Switching Curves

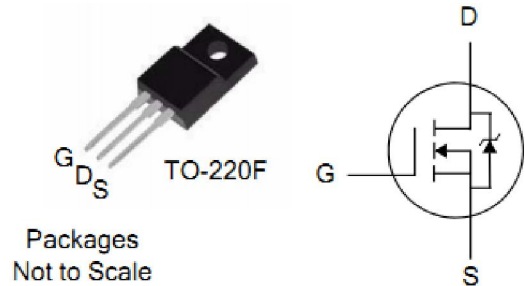

Ordering Information

PART NUMBER	PACKAGE	BRAND
ITA04N65R	TO-220F	IPS

Absolute Maximum Ratings $T_C=25^\circ\text{C}$ unless otherwise specified

Symbol	Parameter	ITA04N65R	Units
V_{DSS}	Drain-to-Source Voltage	650	V
I_D	Continuous Drain Current	4	A
I_{DM}	Pulsed Drain Current, $V_{GS}@10\text{V}$ (NOTE *1)	16	A
P_D	Power Dissipation	30	W
	Derating Factor above 25°C	0.24	W/ $^\circ\text{C}$
V_{GS}	Gate-to-Source Voltage	± 30	V
E_{AS}	Single Pulse Avalanche Energy (NOTE *2)	200	mJ
T_L	Maximum Temperature for Soldering	300	$^\circ\text{C}$
T_J and T_{STG}	Operating Junction and Storage Temperature Range	150, -55 to 150	

Thermal Resistance

Symbol	Parameter	Max.	Units	Test Conditions
$R_{\theta JC}$	Junction-to-Case	4.17	$^\circ\text{C}/\text{W}$	Water cooled heatsink, P_D adjusted for a peak junction temperature of $+150^\circ\text{C}$.
$R_{\theta JA}$	Junction-to-Ambient	62.5		1 cubic foot chamber, free air.



ITA04N65R

OFF Characteristics $T_C=25^\circ\text{C}$ unless otherwise specified

Symbol	Parameter	Min.	Typ.	Max.	Units	Test Conditions
BV_{DSS}	Drain-to-Source Breakdown Voltage	650	--	--	V	$V_{GS}=0V, I_D=250\mu A$
I_{DSS}	Drain-to-Source Leakage Current	--	--	1	μA	$V_{DS}=650V, V_{GS}=0V$ $T_J=25^\circ\text{C}$
		--	--	100		$V_{DS}=520V, V_{GS}=0V$ $T_J=125^\circ\text{C}$
I_{GSS}	Gate-to-Source Forward Leakage	--	--	+100	nA	$V_{GS}=+30V$
	Gate-to-Source Reverse Leakage	--	--	-100		$V_{GS}=-30V$

ON Characteristics $T_J=25^\circ\text{C}$ unless otherwise specified

Symbol	Parameter	Min.	Typ.	Max.	Units	Test Conditions
$R_{DS(ON)}$	Static Drain-to-Source On-Resistance	--	2.4	2.8	Ω	$V_{GS}=10V, I_D=2A$
$V_{GS(TH)}$	Gate Threshold Voltage	2	--	4	V	$V_{DS}=V_{GS}, I_D=250\mu A$
g_{fs}	Forward Transconductance	--	3.5	--	S	$V_{DS}=15V, I_D=2A$

Dynamic Characteristics Essentially independent of operating temperature

Symbol	Parameter	Min.	Typ.	Max.	Units	Test Conditions
C_{iss}	Input Capacitance	--	610	--	μF	$V_{GS}=0V, V_{DS}=25V$ $f=1.0\text{MHz}$
C_{oss}	Output Capacitance	--	53	--		
C_{riss}	Reverse Transfer Capacitance	--	3.5	--		
Q_g	Total Gate Charge	--	14.5	--	nC	$I_D=4A, V_{DD}=520V$ $V_{GS}=10V$
Q_{gs}	Gate-to-Source Charge	--	3	--		
Q_{gd}	Gate-to-Drain ("Miller") Charge	--	6.5	--		

Resistive Switching Characteristics Essentially independent of operating temperature

Symbol	Parameter	Min.	Typ.	Max.	Units	Test Conditions
$t_{d(ON)}$	Turn-on Delay Time	--	14		ns	$V_{DD}=325V, I_D=4A,$ $V_{GS}=10V, R_G=10\Omega$
t_{rise}	Rise Time	--	16			
$t_{d(OFF)}$	Turn-Off Delay Time	--	32			
t_{fall}	Fall Time	--	11			



ITA04N65R

Source-Drain Diode Characteristics

T_c=25°C unless otherwise specified

Symbol	Parameter	Min.	Typ.	Max.	Units	Test Conditions
I _S	Continuous Source Current (Body Diode)	--	--	4	A	T _C =25°C
I _{SM}	Maximum Pulsed Current (Body Diode)	--	--	16	A	
V _{SD}	Diode Forward Voltage	--	--	1.5	V	I _{SD} =4A, V _{GS} =0V
t _{rr}	Reverse Recovery Time	--	256	--	ns	I _F = I _S di/dt=100A/us
Q _{rr}	Reverse Recovery Charge	--	1200	--	nC	

Notes:

*1. Repetitive rating; pulse width limited by maximum junction temperature.

*2. L=10mH, I_D=6.3A, Start T_J=25°C

Characteristics Curve

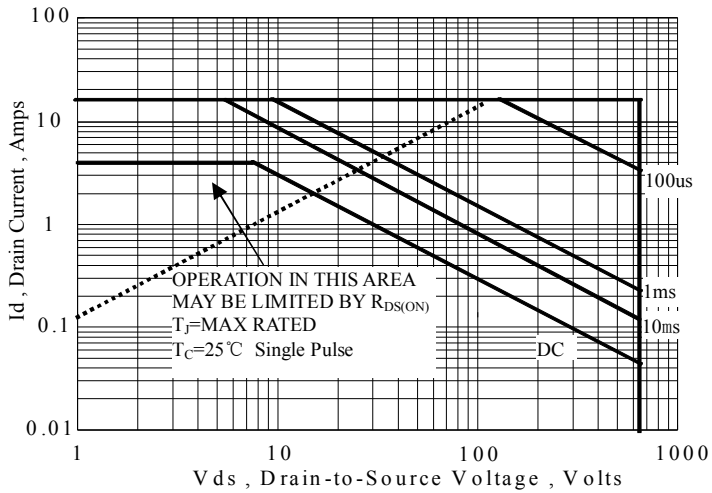

Figure 1 Maximum Forward Bias Safe Operating Area

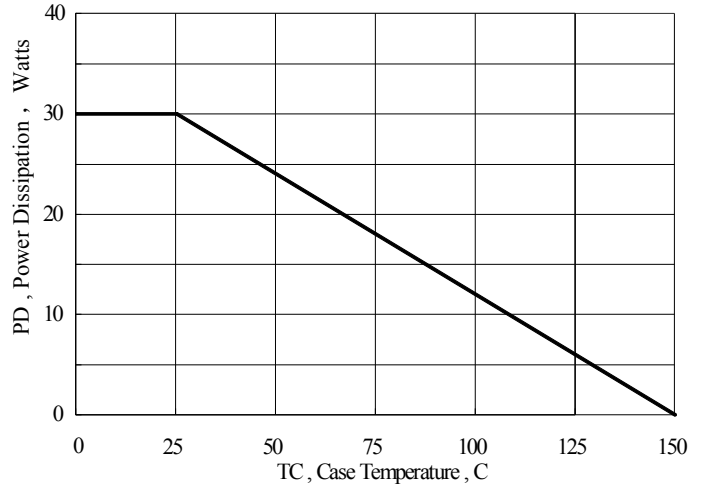

Figure 2 Maximum Power Dissipation vs Case Temperature

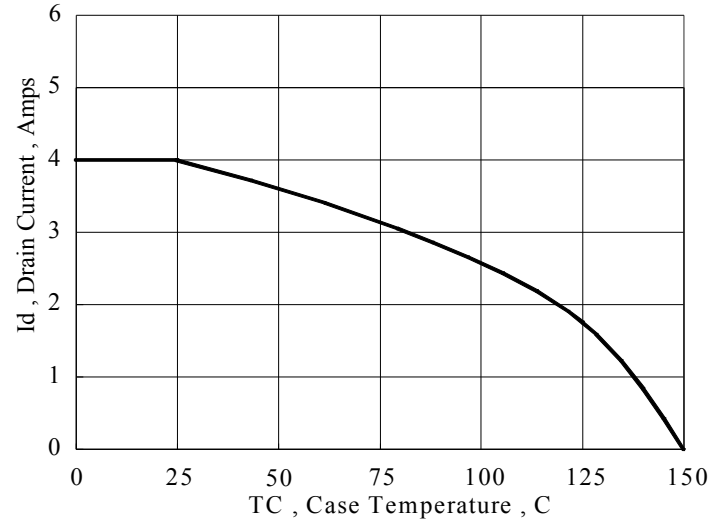

Figure 3 Maximum Continuous Drain Current vs Case Temperature

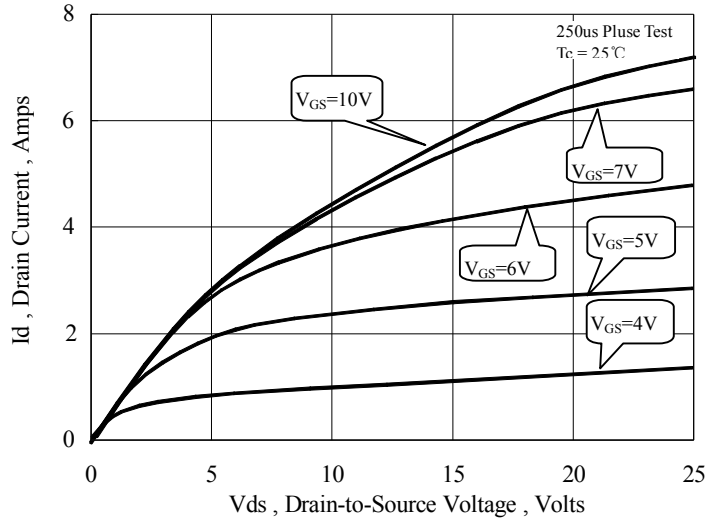

Figure 4 Typical Output Characteristics

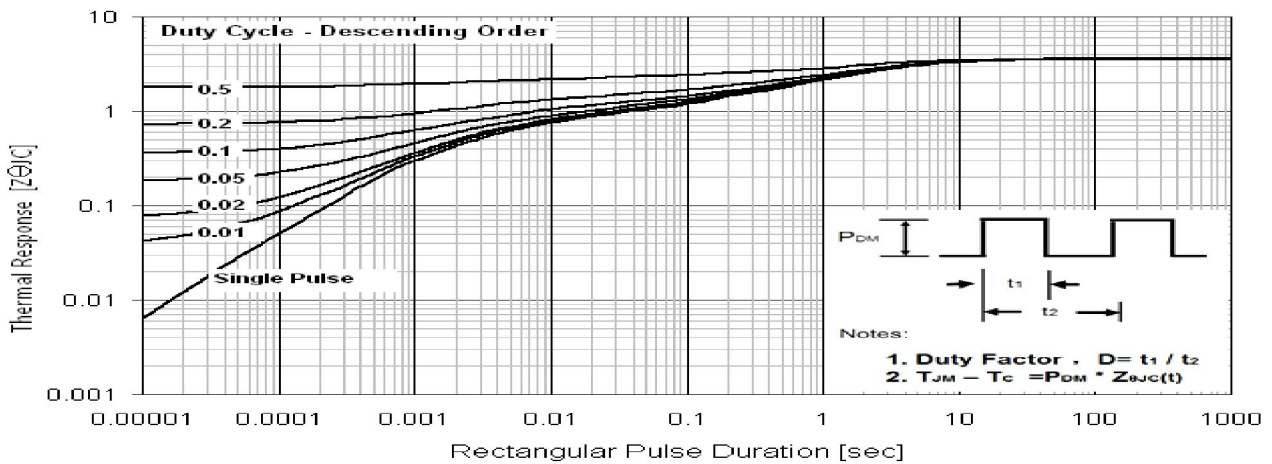

Figure 5 Maximum Effective Thermal Impedance , Junction to Case

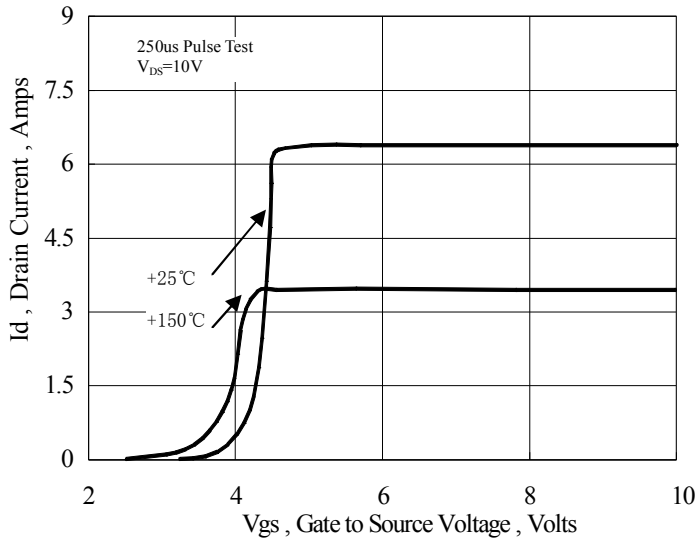

Figure 6 Typical Transfer Characteristics

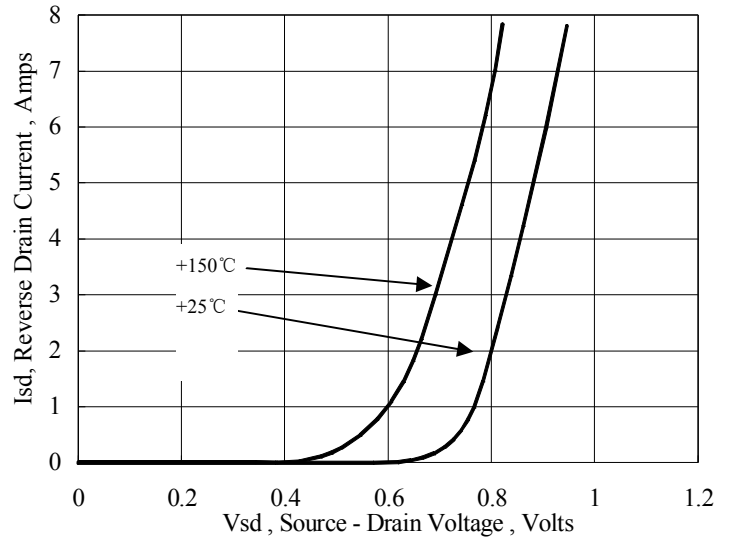

Figure 7 Typical Body Diode Transfer Characteristics

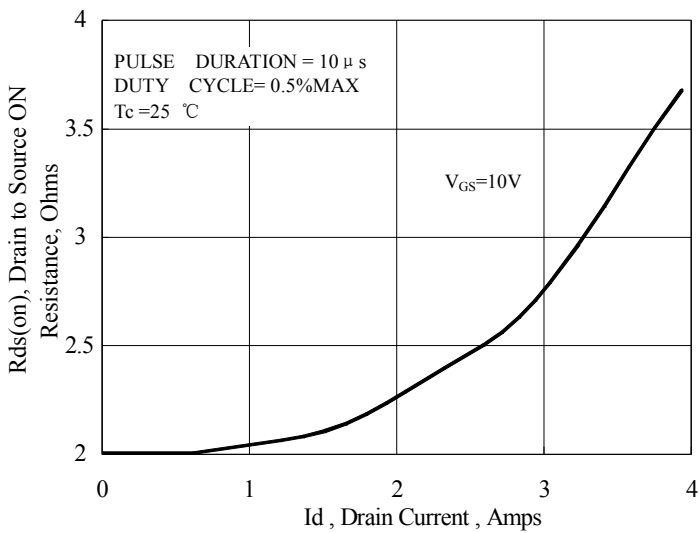

Figure 8 Typical Drain to Source ON Resistance vs Drain Current

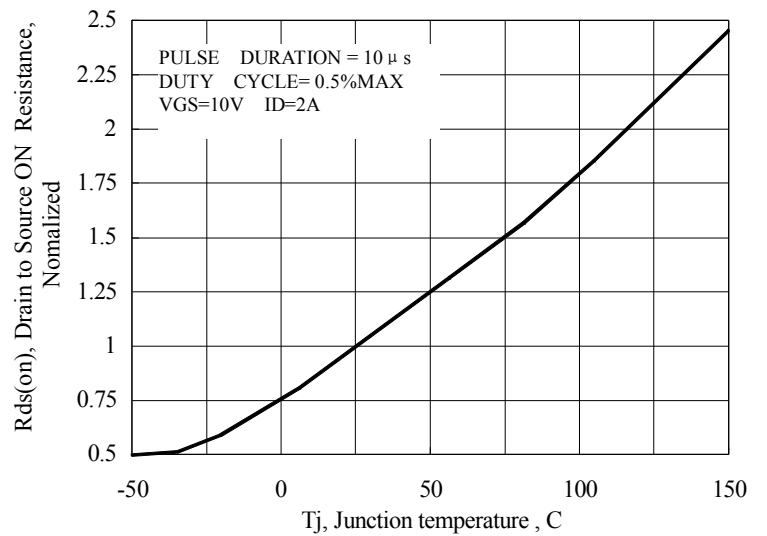

Figure 9 Typical Drain to Source on Resistance vs Junction Temperature

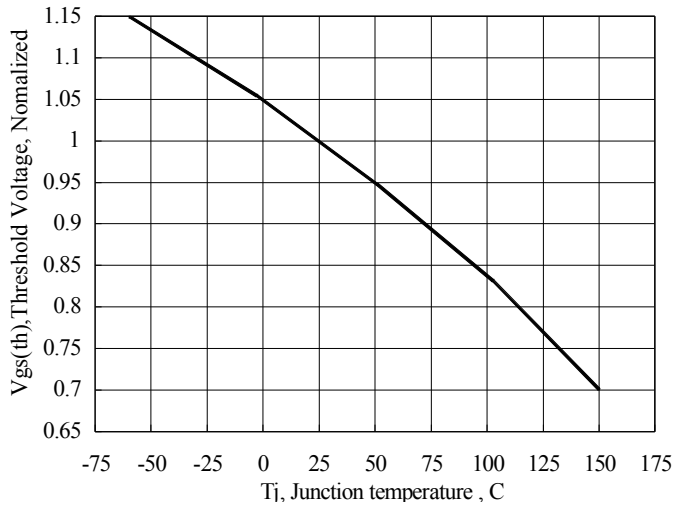

Figure 10 Typical Theshold Voltage vs Junction Temperature

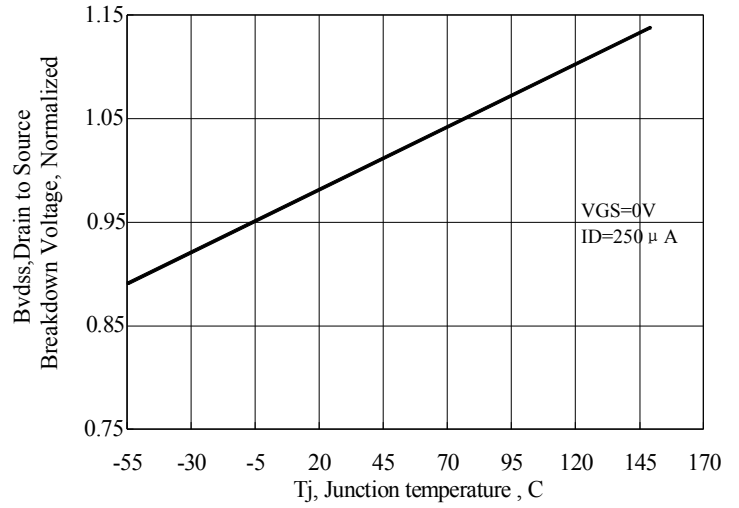

Figure 11 Typical Breakdown Voltage vs Junction Temperature

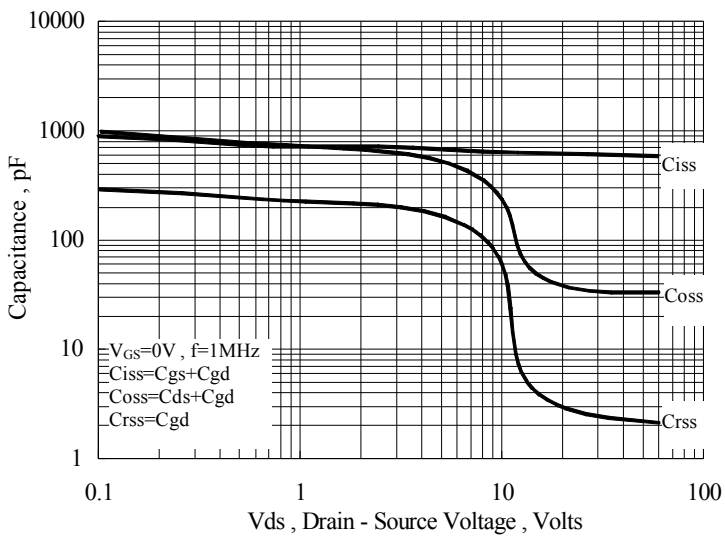

Figure 12 Typical Capacitance vs Drain to Source Voltage

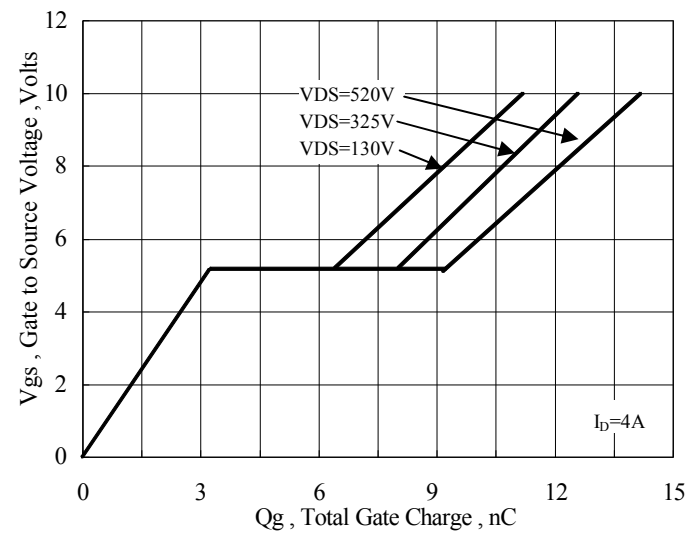

Figure 13 Typical Gate Charge vs Gate to Source Voltage

Test Circuits and Waveforms

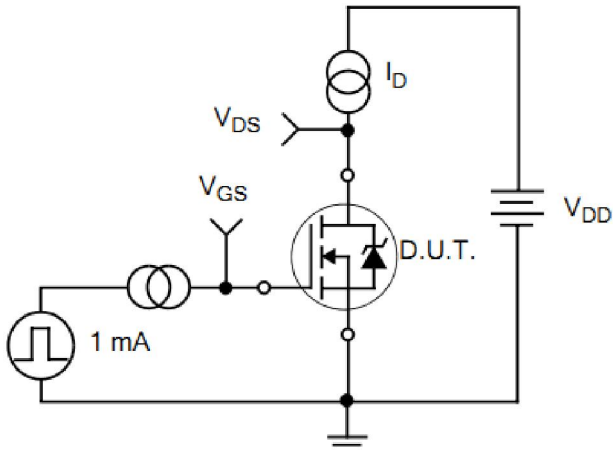

Figure 14. Gate Charge Test Circuit

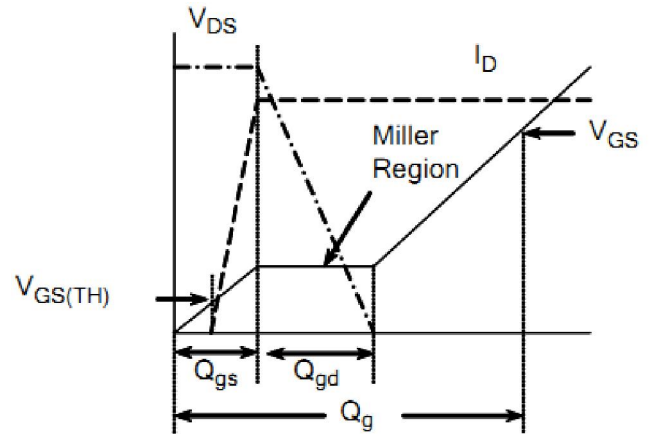

Figure 15. Gate Charge Waveforms

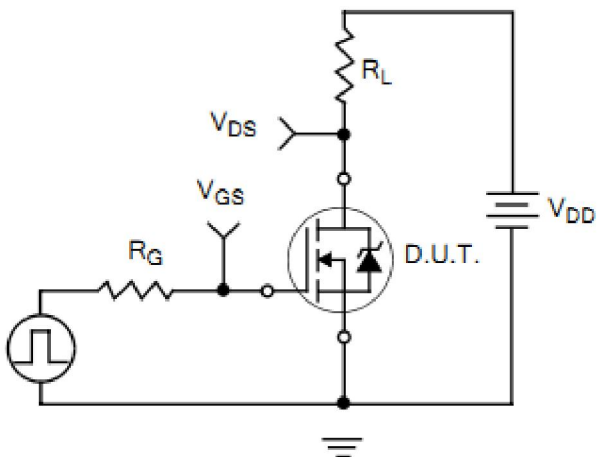

Figure 16. Resistive Switching Test Circuit

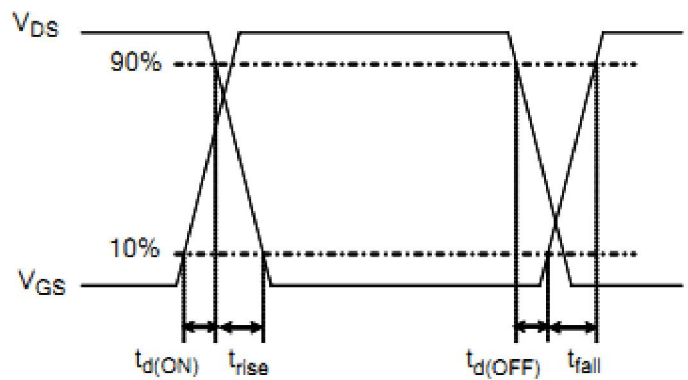

Figure 17. Resistive Switching Waveforms

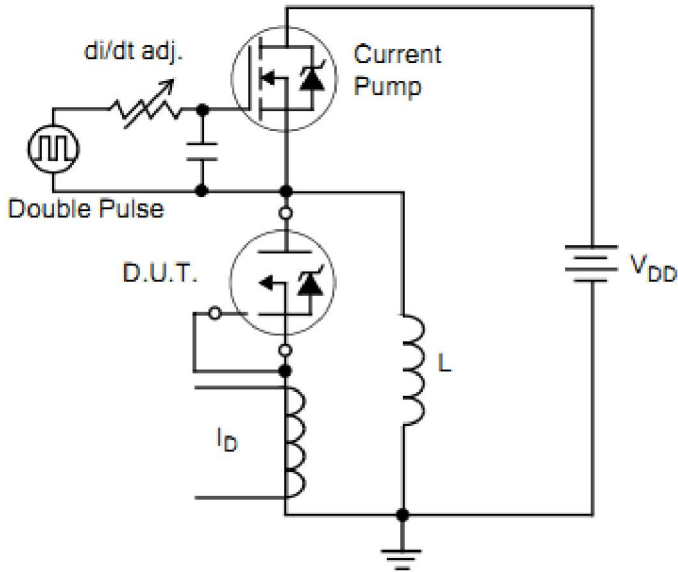

Figure 18. Diode Reverse Recovery Test Circuit

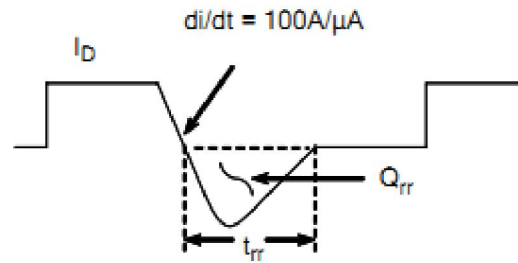

Figure 19. Diode Reverse Recovery Waveform

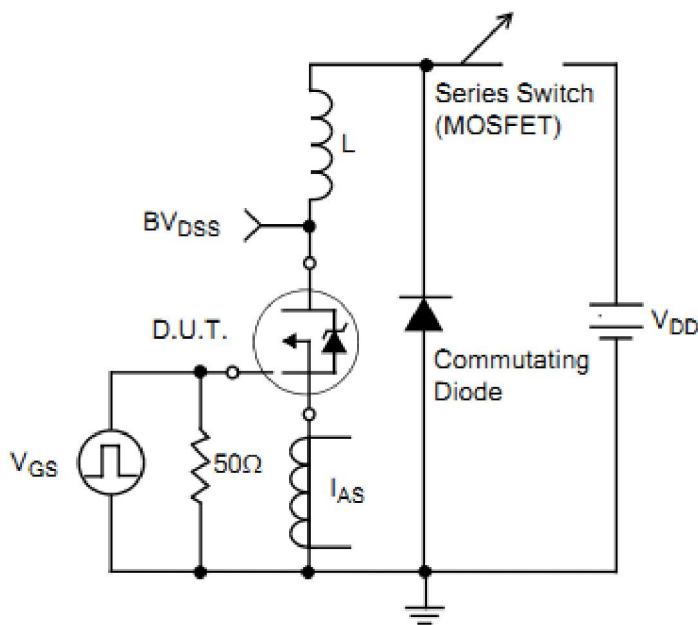

Figure 20. Unclamped Inductive Switching Test Circuit

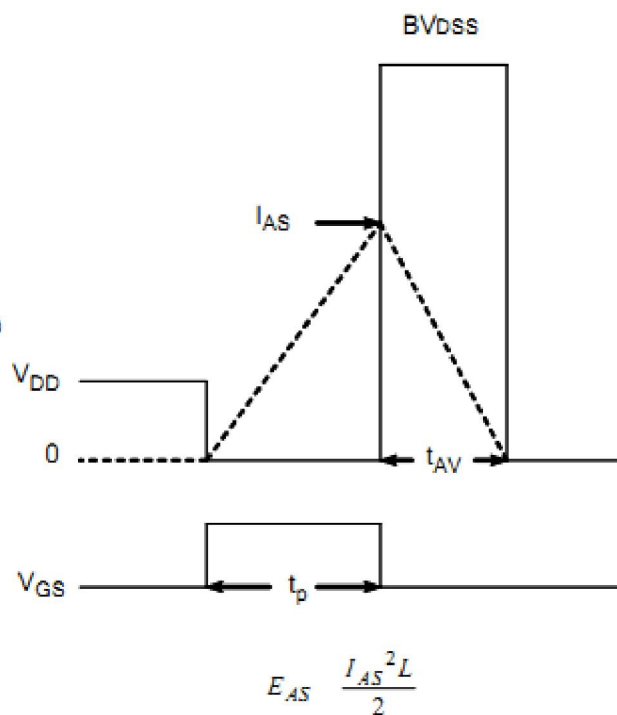

Figure 21. Unclamped Inductive Switching Waveform



Disclaimers:

InPower Semiconductor Co., Ltd (IPS) reserves the right to make changes without notice in order to improve reliability, function or design and to discontinue any product or service without notice. Customers should obtain the latest relevant information before orders and should verify that such information is current and complete. All products are sold subject to IPS's terms and conditions supplied at the time of order acknowledgement.

InPower Semiconductor Co., Ltd warrants performance of its hardware products to the specifications at the time of sale, Testing reliability and quality control are used to the extent IPS deems necessary to support this warrantee. Except where agreed upon by contractual agreement, testing of all parameters of each product is not necessarily performed.

InPower Semiconductor Co., Ltd does not assume any liability arising from the use of any product or circuit designs described herein. Customers are responsible for their products and applications using IPS's components. To minimize risk, customers must provide adequate design and operating safeguards.

InPower Semiconductor Co., Ltd does not warrant or convey any license either expressed or implied under its patent rights, nor the rights of others. Reproduction of information in IPS's data sheets or data books is permissible only if reproduction is without modification or alteration. Reproduction of this information with any alteration is an unfair and deceptive business practice. InPower Semiconductor Co., Ltd is not responsible or liable for such altered documentation.

Resale of IPS's products with statements different from or beyond the parameters stated by InPower Semiconductor Co., Ltd for that product or service voids all express or implied warranties for the associated IPS's product or service and is unfair and deceptive business practice. InPower Semiconductor Co., Ltd is not responsible or liable for any such statements.

Life Support Policy:

InPower Semiconductor Co., Ltd's products are not authorized for use as critical components in life support devices or systems without the expressed written approval of InPower Semiconductor Co., Ltd.

As used herein:

1. Life support devices or systems are devices or systems which:
 - a. are intended for surgical implant into the human body,
 - b. support or sustain life,
 - c. whose failure to perform when properly used in accordance with instructions for used provided in the labeling, can be reasonably expected to result in significant injury to the user.
2. A critical component is any component of a life support device or system whose failure to perform can be reasonably expected to cause the failure of the life support device or system, or to affect its safety or effectiveness.