

**TECHNICAL TRAINING**

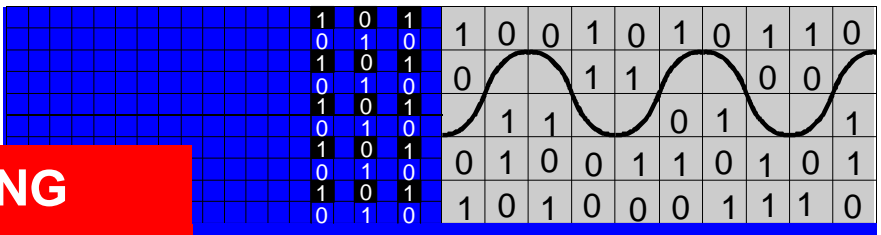

# ITC008 Technical Training Manual

The screenshot shows a menu interface for 'ALERT GUARD'. The menu items are: 'ALERT GUARD', 'Go back', 'Alert options', 'Locations', 'News weather', and 'NWR channel'. The 'Alert options' item is highlighted with an orange bar. Below the menu items, there is a dark blue box containing the text: 'Set how Alert Guard will respond to different levels of alert.'



# THOMSON



## FOREWORD

The ITC008 training course is an objective based training course designed to provide the service technician with information key to the servicing of the chassis. This training course is to be used in conjunction with the service data and additional information found in the ESI Service Data. Upon completion of this training course the service technician will:

- Have a basic understanding of features and menu's
- Gain a block diagram understanding of major systems and their function
- Identify key circuits and use troubleshooting procedures to service those circuits
- Isolate a dead set condition to a defective circuit or component area.

## SAFETY INFORMATION CAUTION

Safety information is contained in the appropriate Thomson Service Data. All product safety requirements must be complied with prior to returning the instrument to the consumer. Servicers who defeat safety features or fail to perform safety checks may be liable for any resulting damages and may expose themselves and others to possible injury.



All integrated circuits, all surface mounted devices, and many other semiconductors are electrostatically sensitive and therefore require special handling techniques.

First Edition - First Printing  
Copyright 2003 Thomson  
Trademark(s)<sup>®</sup> Registered Marca(s) Registrada(s)  
Printed in U.S.A.

Prepared by  
Thomson  
Technical Training Department, INH905  
PO Box 1976  
Indianapolis, Indiana 46206 U.S.A.



**THOMSON**

**RCA SCENIUM**

# Contents

<b>FOREWORD .....</b>	<b>3</b>
<b>SAFETY INFORMATION CAUTION .....</b>	<b>3</b>
<b>INTRODUCTION .....</b>	<b>6</b>
<b>ALERT GUARD OVERVIEW .....</b>	<b>7</b>
<b>CUSTOMER MENUS .....</b>	<b>11</b>
<b>OVERVIEW .....</b>	<b>13</b>
<b>CIRCUIT OVERVIEW .....</b>	<b>16</b>
<b>AUDIO VIDEO PROCESSING .....</b>	<b>16</b>
<b>MAV CBA SWITCHING .....</b>	<b>17</b>
<b>MAIN CBA PROCESSING .....</b>	<b>18</b>
<b>SYSTEM CONTROL .....</b>	<b>20</b>

# Contents

<b>POWER SUPPLY .....</b>	<b>22</b>
<b>SWITCHED POWER SUPPLY .....</b>	<b>24</b>
<b>HORIZONTAL DEFLECTION .....</b>	<b>25</b>
<b>E/W CORRECTION.....</b>	<b>26</b>
<b>VERTICAL DEFLECTION .....</b>	<b>28</b>
<b>SHUTDOWN .....</b>	<b>30</b>
<b>TROUBLESHOOTING .....</b>	<b>32</b>
<b>DEAD SET TROUBLESHOOTING .....</b>	<b>32</b>
<b>SHUTDOWN TROUBLESHOOTING .....</b>	<b>34</b>
<b>HORIZONTAL TROUBLESHOOTING .....</b>	<b>36</b>
<b>SYSTEM CONTROL TROUBLESHOOTING .....</b>	<b>37</b>

## Introduction

New for 2003 is the ITC008 chassis. The **ITC** in **ITC008** stands for International Television Chassis. Designed after the TX809, the ITC008 will be used in other countries and the US. This chassis will replace the TX series and CTC203 core line chassis. Screen sizes for the ITC008 include 13 " to 36". An E/W module is used for pincushion correction on the larger screen sizes. A new Ultimate One Chip (UOC) system control and single audio / video switch IC is used in the ITC008. Other additions to the ITC008 are YPrPb input and the US version will incorporate the Alert Guard module.

Other features of the set include:

- Universal Remote with Alert Guard buttons
- Chipper Check connection "TECI Bus" (Thomson Equipment Communications Interface)
- Shared inputs S-Video / Composite / Y
- Audio Output
- Kid Pass

The ITC008 training course will cover:

- **Overview of Alert Guard and how it works**
- **Basic understanding of features and menu's:** This includes new menu items associated with Alert Guard.
- **Overview of chassis**
- **Key circuits:** Key circuits being power supplies, deflection, shutdown, and system control.
- **Dead set troubleshooting**

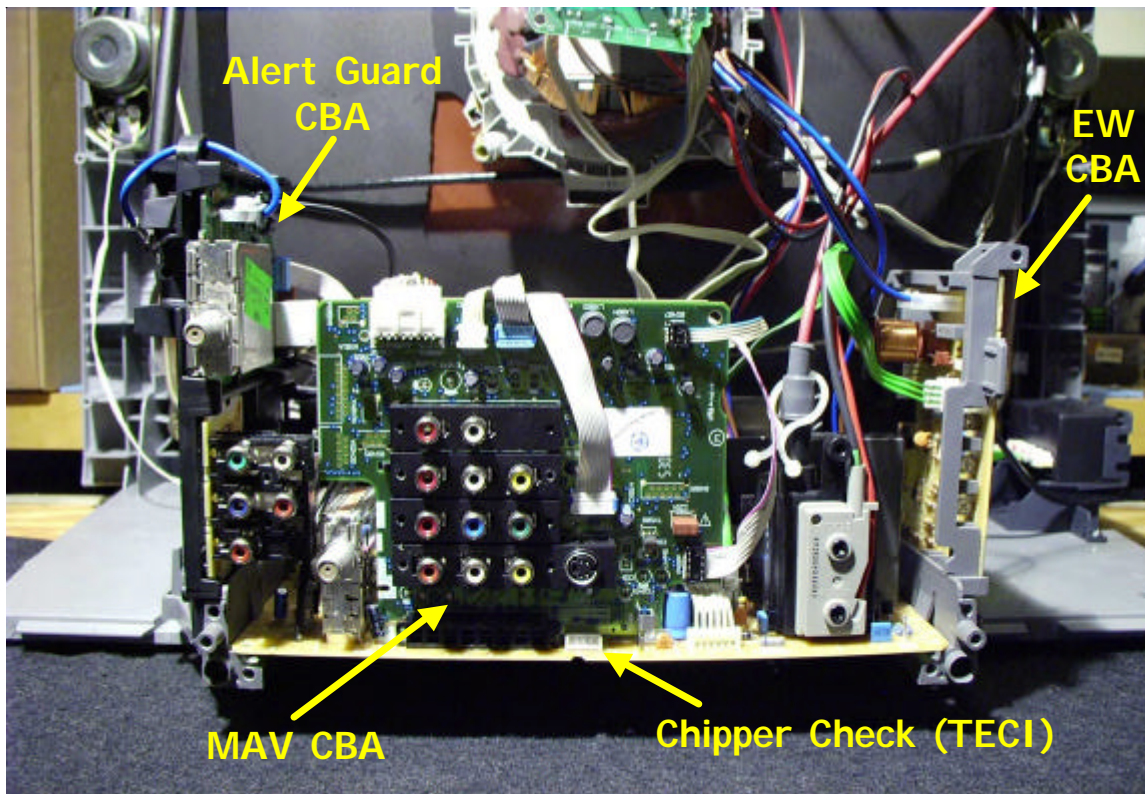

**Chassis Layout**

## **Alert Guard Overview**

Alert Guard is designed to detect alerts that include 30-plus natural disasters such as avalanches, blizzards, forest fires, tsunamis, hurricanes, tornados, volcanoes, flash floods, and earthquakes. Local and state emergency alerts cover chemical spills, nuclear power plant emergencies, gas line breaks, chemical storage center mishaps, train derailments and refinery fires, among others. The system also provides for high-level state or federal emergencies such as terrorist alerts, bio-warfare alerts, bombing threats and immediate life-threatening emergencies relayed by FEMA and NOAA over the all hazard NWR (NOAA Weather Radio) network from several federal agencies. In the event of an emergency, the decoded data is displayed as text on the TV and or the audio alert is announced via the TV's speakers.

The Alert Guard module in the ITC008 allows the set to receive alert information from NOAA (National Oceanic and Atmospheric Administration). This information can be displayed as text or audio from the National Weather Radio service. Alert Guard receives digital data known as SAME (Specific Area Message Encoding) combined with audio information provided by NOAA Weather Radio (NWR) and alerts the consumer to various levels of emergency.

NOAA has numerous transmitter towers across the US transmitting on any one of seven frequencies. This level of coverage allows NOAA to cover just about every household in the US. **Note:** For more information about NOAA, visit [www.noaa.gov](http://www.noaa.gov).

162.400 MHz	162.425 MHz	162.450 MHz	162.475 MHz	162.500 MHz	162.525 MHz	162.550 MHz
----------------	----------------	----------------	----------------	----------------	----------------	----------------

***NWR Frequencies***

There are four status levels for Alert Guard:

1. System Ready (Green LED)
2. Advisory (Yellow LED)
3. Watch (Orange LED)
4. Warning (Red LED)

System Ready indicates that a NWR signal is being received from one of the seven frequencies setup by NOAA and decoded. The LED will be lit only when the NWR signal is strong enough to decode the SAME data. This is not an indication that the NWR signal being received is correct for a particular area only that a signal is being received.

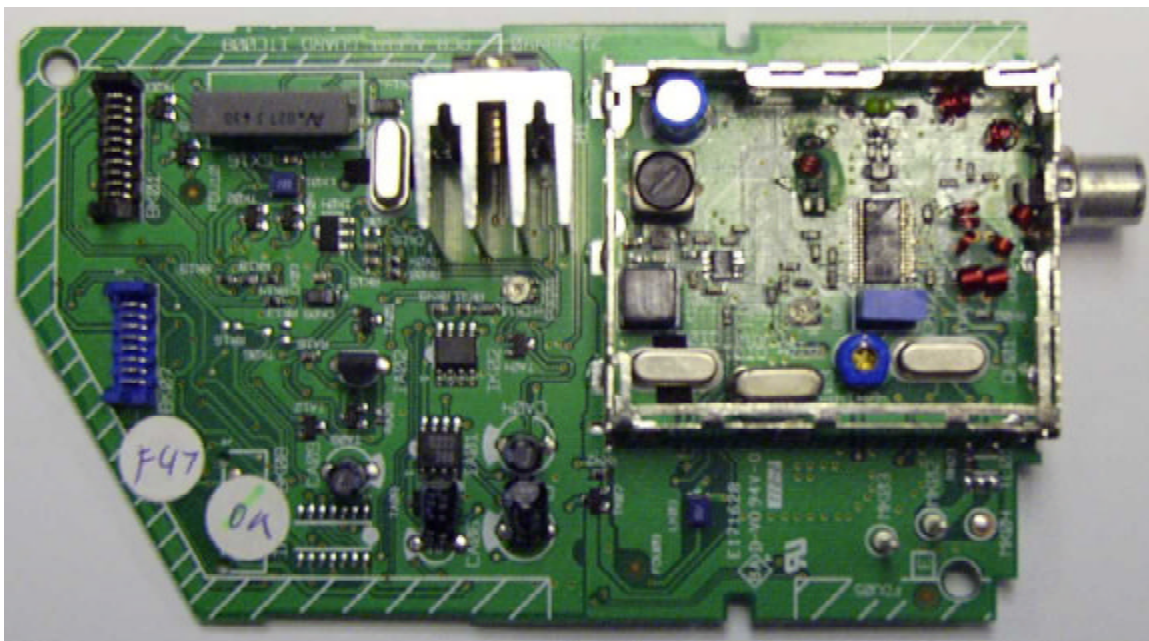

***Alert Guard CBA***



**Advisory** indicates conditions when the area setup by the user is listed in a advisory condition. The Advisory conditions are: *Administrative Message Child Abduction Emergency (AMBER alerts), Emergency Action Termination, Flash Flood Statement, Flood Statement, Hurricane Statement, Local Area Emergency, National Information Center Message, Network Message Notification, 911 Telephone Outage Emergency, Severe Weather Statement, and Special Weather Statement.*

NOAA conducts a weekly test for the all hazards broadcast system. The test is once a week on Wednesday between 10 a.m. and 12 noon for approximately 15 minutes. The yellow ADVISORY light blinks during the test. If there is ongoing severe weather or a threat of severe weather, the test is postponed until the next available good-weather day. Alert Guard uses this test to ensure proper setup of channel and location. If Alert Guard detects a problem, on-screen messages appear to provide help.

**Watch** indicates conditions when the area setup by the user is listed in a Watch condition. The Watch conditions are: *Avalanche Watch, Coastal Flood Watch, Flash Flood Watch, Flood Watch, High Wind Watch, Hurricane Watch, Severe Thunderstorm Watch, Tornado Watch, Tropical Storm Watch, Tsunami Watch, and Winter Storm Watch*

**Warning** indicates conditions when the area setup by the user is listed in a warning condition. The warning conditions are: *Avalanche Warning, Blizzard Warning, Civil Danger Warning, Civil Emergency Message, Coastal Flood Warning, Dust Storm Warning, Earthquake Warning, Emergency Action Notification, Fire Warning, Flash Flood Warning, Flood Warning, Hazardous Materials Warning, High Wind Warning, Hurricane Warning, Immediate Evacuation, Law Enforcement Warning, Nuclear Power Plant Warning, Practice/Demo Warning, Radiological Hazard Warning, Severe Thunderstorm Warning, Shelter in Place Warning, Special Marine Warning, Tornado Warning, Tropical Storm Warning, Tsunami Warning, Volcano Warning, and Winter Storm Warning.*

The Alert Guard system broadcasts alerts for the U.S. U.S. territories, possessions and associated states. The TV can't receive any alerts for locations outside these areas. Also, if alerts are issued for areas other than those that are set in the *Location* menu, Alert Guard won't notify the user of these alerts.

There are several Alert Guard menus that the user can use to setup and customize Alert options.

#### Alert Guard Menus:

- Alert Options
- Locations
- News Weather
- NWR Channel

Alert Options have to do with how the alert is sounded, type of alarm, and or text display. These options are customized for each of the three alert types. Different types of alarms can be set for each alert. This allows the user hear a different alarm for each of the alert types. The alarm volume is also set independent for each alert.

Locations menu provides up to four area locations starting with My Area. My Area is the location of the set. Areas 1-3 are used for the surrounding areas. Only areas listed in the NWR broadcast will remain in area setup. In other words if the user lives in Texas and selects a location in Florida, the Florida area will be removed when the next NWR test is conducted. This is also true for adjoining counties that are covered by different transmitters.

News Weather allows the user to select the local news weather channel to go to when the news weather button is pressed. There are four locations the user can setup. When the user pushes the news weather button the set will toggle through each of the four choices, similar to a favorite channel list with only four channels.

NWR Channel sets the strongest NWR radio station received. If more then one station is heard in the area, the strongest station will be stored. The user has the option to manually set this to the proper station for their location.

## Customer Menu

There are five main menu items for the standard ITC008. The Alert Guard version has an additional setup menu for Alert Guard. The five standard menu items cover the typical customer menu options found in most TV's. These menu options are:

- Sound
- Picture
- Setup
- Parental Control
- Time
- Alert Guard (Alert Guard equipped sets)

### Sound Menu

The sound menu allows the user to customize the audio by adjusting base, treble, and balance. Stereo mode selection includes mono, stereo, and enhanced. SAP (secondary audio programming), internal speakers and auto volume level can be turned on or off in the sound menu. Audio out can be set to fixed or variable.

### Picture Menu

The picture menu provides the user with options to customize picture settings. These setting include:

- Brightness
- Contrast
- Color
- Tint
- Tilt (on some sets)

Picture preset option allows the user to select from bright, natural, personal, and soft. These settings are preset at the factory and only the personal setting can be customized by the above adjustments. Auto color and Color warmth settings are also included in the picture menu.

## Setup Menu

- Auto Channel Search
- List and Labels
- Closed Caption
- Auto Tuning
- Language

## Parental Control

New parental controls, which work with a simple password, include a wide variety of options including setting the maximum hours viewed per day before automatically shutting down. The Kid Pass allows the parent to set how long the viewing time of the set is for each day of the week. The times are set in 30 min increments and after the set has been on for the preset length of time it will shutdown. The password will need to be entered for set operation after the Kid Pass time has expired. Kid Pass is only available after the time is set.

**NOTE:** The password can be reset if it is unknown. First make sure the TV is off. Then simultaneously press and hold VOL< on the TV's front panel and CLEAR on the remote for approximately 5 seconds.

## Time Menu

The time menu is used to set the correct time. This is critical for Kid Pass operation and will be blocked by password when Kid Pass is set.

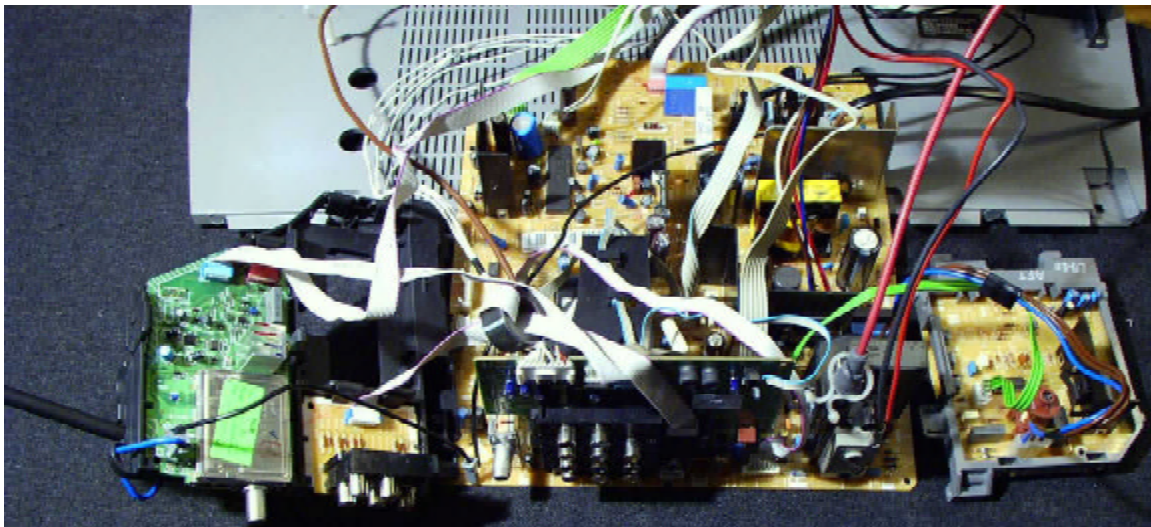

***ITC008 Chassis Layout***

## Overview

The ITC008 is a conventional NTSC analog color television chassis that uses the latest integration technology to improve performance and reliability. This can be seen with the use of an I<sup>2</sup>C-bus-controlled Ultimate One Chip (IV001) and dual audio video switch IC IX401.

The main functions and features of IV001 are:

- System control and user interface
- Horizontal and vertical geometry processing
- Horizontal synchronization with two control loops and alignment free oscillator
- Vertical count-down circuit
- Vertical driver for DC-coupled vertical output stages
- I<sup>2</sup>C Bus control of all geometry functions
- X-ray protection
- Tuner PIF and SIF processing
- Final RGB processing and CRT pre-drive
- Alignment and setup settings for IV001 are stored in EEPROM IR01

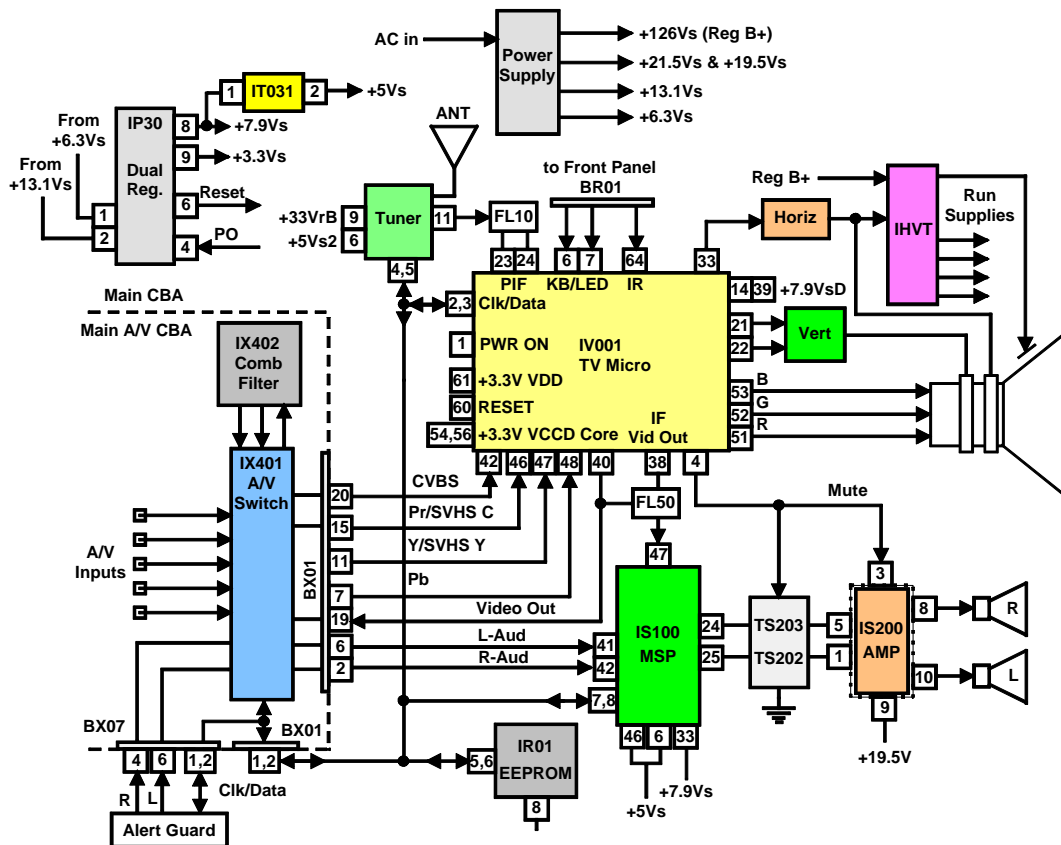

**System Block**

The integration technology can be seen in the ITC008 block diagram. The block diagram is centered on IV001 and IR01 EEPROM. Inputs from tuner, main AV CBA, and the front panel go to IV001. Outputs from IV001 are used to drive horizontal, vertical, and the picture tube.

All audio and video signals enter the chassis via the Main A/V CBA. The main A/V CBA is home to two IC's, IX402 comb filter and IX401 audio and video switch. The video signals passing through this board are processed and converted to RGB by IX401. The RGB signals are passed to IV001 for further processing before being sent to the CRT.

Switched and IF audio is processed by IS100 multi-sound processor (MSP) before being sent to the speakers. Volume control, Stereo, balance, and tone features are performed by IS100. Switching from tuner IF to external R/L input is also performed by IS100. Output from IS100 (R/L) passes through mute transistors, TS202 and TS203, on it's way to the final amp IS200. IS200 is a 5-Watt single chip stereo amp used to drive the internal speakers.

Alert Guard audio enters the Main A/V In CBA via BX07. IX401 routes the signal to the speakers when selected by the user or when an alert is broadcast. Because Alert Guard functions when the set is turned off, the audio circuit and switching are powered by the main power supply.

The main power supply is on whenever AC power is applied to the set generating the +126Vs (Reg B+), +21.5Vs, 19.5Vs, and +13.1Vs. The +13.1Vs is used for IP30 Dual Reg. that is switched by IV001 pin 1. This turns on the +7.9Vs providing power to the deflection and video processing sections of IV001. The +3.3Vs is not switched by IP30 only regulated.

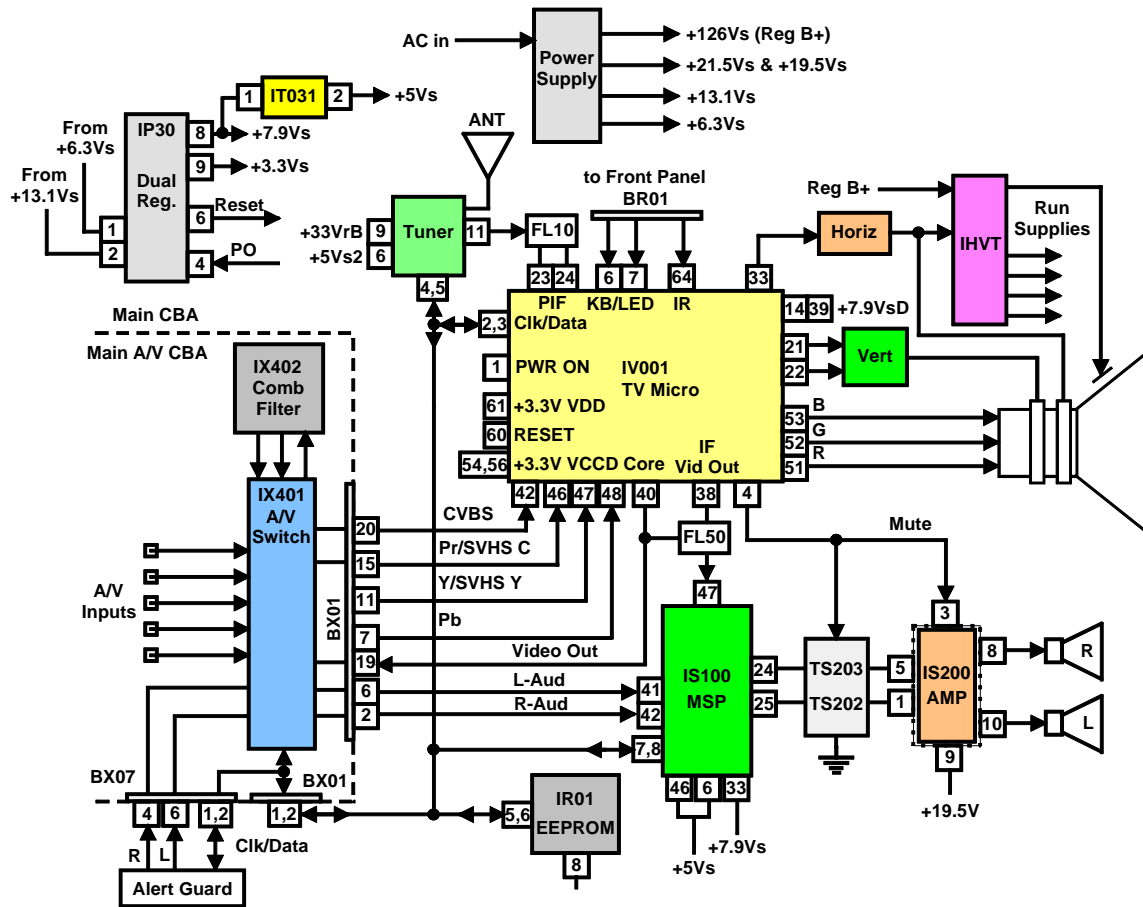

**System Block**

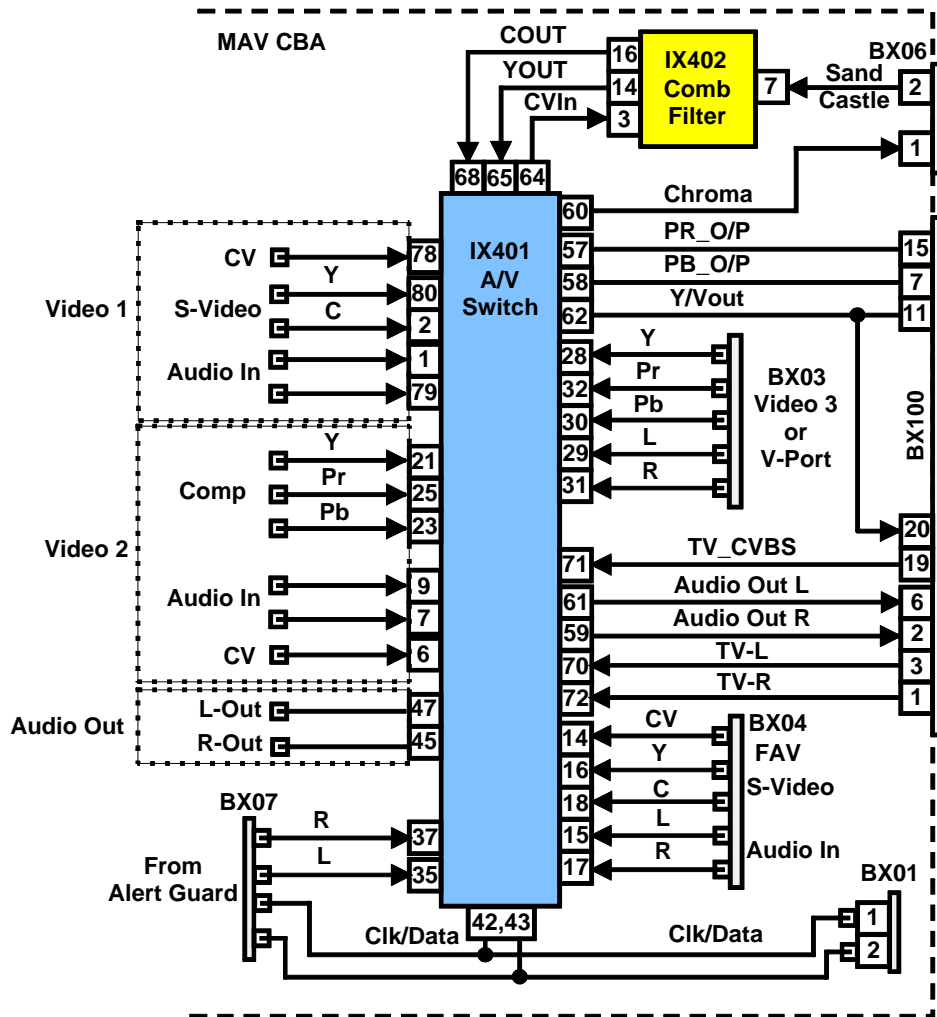

## MAV Switching Block

### Circuit Overview

#### Audio Video Processing

The A/V Processing on the ITC008 can be divided into two parts, MAV CBA (**switching**) and Main Chassis (**processing**). The MAV CBA provides switching of all external signals via IX401 audio video switch IC. IX401 is I2C bus controlled and is capable of up to four switched inputs. IX402, Comb Filter, separates out the Y and C components of the composite signal for switching by IX401. The main chassis process the Y Pr Pb signal from IX401 using the Ultimate One Chip (IV001). The processed RGB signal is then fed to the CRT driver.



There are up to four external inputs connected to the main AV in CBA. These inputs are:

- Video 1 (VID1)
- Video 2 (VID2)
- Front (FRNT)
- Component or V-Port (CVID3)

NOTE: () = OSD name for selected input. Video 1,2 and Front will display type of video detected. i.e. Video 1 detects S-Video the display will show SVID1.

### **MAV CBA Switching**

Video 1 and 2 are composite video (CV) with input 1 sharing S-Video. Front input also shares S-Video with the CV input. Video 2 is shared by composite and component video. In addition, the ITC008 can be setup for V-Port or a second component input.

Tuner video or TV\_CVBS comes from the main CBA to pin 19 of BX100 to IX401 pin 71. This CV signal is output to IX402 at pin 64 of IX401 where it is Y / C separated. IX402 comb filter outputs the Y / C to pins 65 and 68 of IX401. The now Y / C signal is switched and returned to the main CBA for further processing via BX06-1 (C) and BX100-20 (Y). Corresponding audio comes from the main CBA to IX401 pins 70 and 72 via BX100 connector. The switched audio returns to the main CBA from pins 59 and 61 of IX401 for further processing and amplification. Video 1, video 2, and front CV are also processed through IX402 while S-Video bypasses IX402.

Component video (Y Pr Pb) is switched by IX401 and output from pins 57, 58, and 62. Pin 62 of IX401 has Y signal for both component and Y / C signal. This Y/Vout signal is sent to two pins on BX100. Pin 11 is seen by the main CBA as the Y signal from component and pin 20 is seen by the main CBA as the Y signal from Y / C. The selection between component and Y / C is done by IV001 on the main CBA. See *Processing for further details*.

A sand castle pulse is used by IX402 for processing and timing. The signal comes from the main CBA via connector BX06 pin 2. Connector BX01 carries the clock and data signal from IV001 on the main CBA to IX401 pins 42 and 43. The clock and data signal also goes to the Alert Guard module via BX07. Audio from Alert Guard is switched by IX401 at pins 37 and 35.

### **Main CBA Processing**

The Y Pr Pb signals from BX100 (pins 7, 11 and 15) are connected to the RGB input of IV001 pins 46, 47, and 48 respectively. This input becomes active when the fast blanking signal at pin 45 is  $\geq 0.8V$ . RGB is converted to YUV in the internal matrix, so color saturation alignment, black stretching and de-matrix coefficient switching can be done. Fast blanking insertion bit IN2 is high when a fast blanking signal is detected before the end of vertical blanking (1 line). Due to this concept full-page detection is done in an easy way.

The RGB input of the Ultimate One Chip IC can be configured as a component input. This mode is used for models with component inputs. In component input mode, G becomes Y input, R becomes Pr input and B become Pb input. Y input has to be present at the external CVBS video input (pin 42) for synchronization. Component input becomes active when pin 45 is  $\geq 0.8V_{dc}$ .

The Ultimate One Chip IC decodes PAL, NTSC and SECAM signals. The PAL/NTSC decoder needs no external reference crystals but has an internal clock generator, which is stabilized to the required frequency by using the 12MHz clock-signal from the reference oscillator of the micro section of IV001.

Internal to IV001 video processing is a base-band delay line. The delay line is active during NTSC to obtain a good suppression of cross color effects. The demodulated color difference signals are internally supplied to the delay lines.

In the video section of the Ultimate One Chip, all signals are converted to YUV and then to R-Y, G-Y, and B-Y. The R-Y, G-Y, and B-Y signal is further processed by user controls such as contrast, brightness, and tint. Luminance delay, peaking and Black Stretch functions are also internal.

The black stretch circuit extends the grey signal level towards the actual black level, which is measured during burst key. The amount of extension depends on the difference between actual black level and the darkest part of the incoming video signal; it is thus dependent on the IRE value of the video signal.

The external CVBS video inputs are connected to IV001-42 (CVBS/Y), the internal CVBS signal coming from tuner is coming out of IV001-38, passes the sound trap circuit and is transmitted to pin40 via coupling capacitor. For models with SCI or MAV board, the internal CVBS signal is connected to SCI or MAV board for switching via pin 19 of BV001. The selected signal could be a CVBS or S-video signal. The CVBS or Y signal is connected back to UOC via pin 20 of BV001.

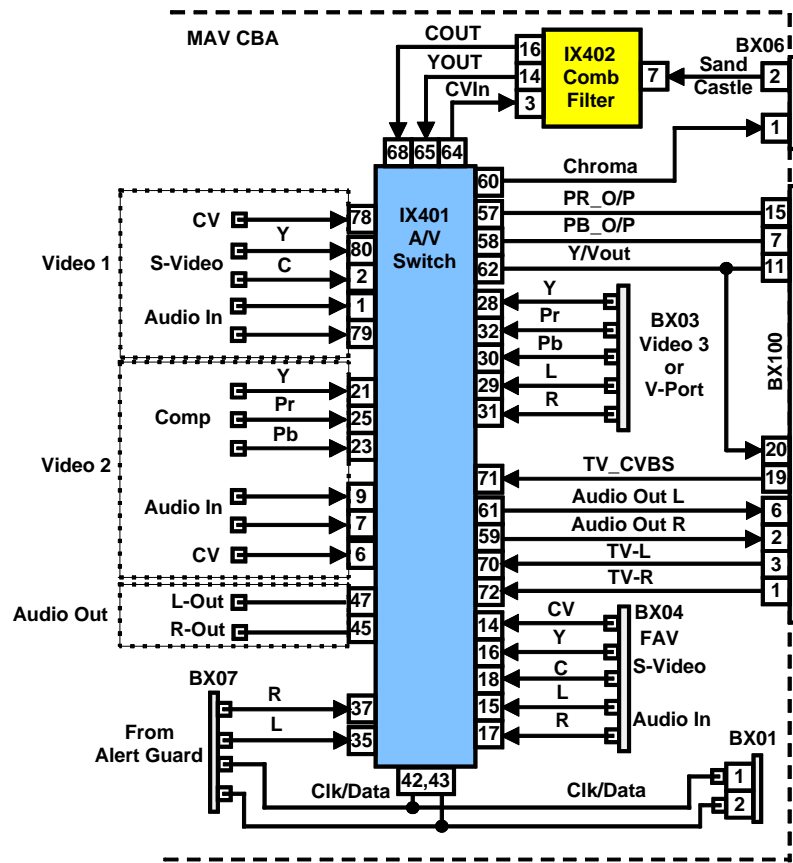

**MAV Switching Block**

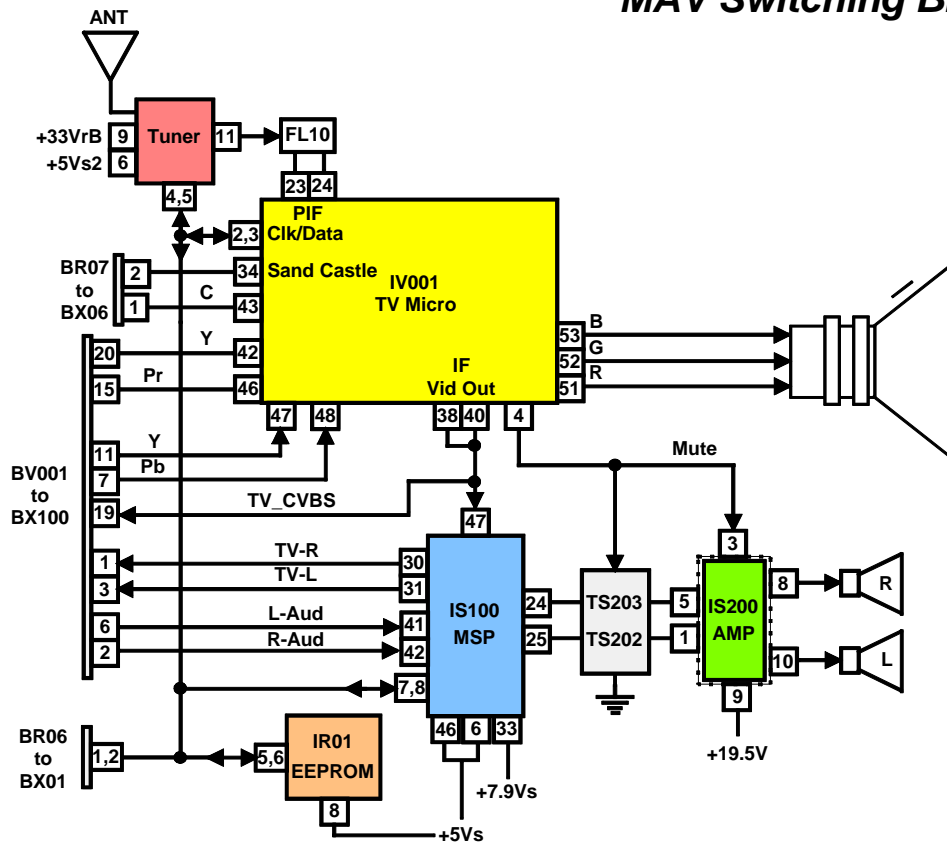

**Main AV Processing Block**

## System Control

System control for the ITC008 is housed in the Ultimate One Chip IV001. User interface is via IR at pin 64 and key scan at pins 6 and 7 of IV001. The UOC operates on +3.3Vdc for system control half and 12Mhz system clock. An external EEPROM (IR001) is used to store alignment and user setup data.

Communication with the rest of the chassis and Alert Guard is via I2C. Besides Alert Guard, there are three devices that communicate with IV001:

- Multi-Sound Processor (IS100)
- Video IC (IX401)
- Tuner

If communication is not established with these devices, IV001 will try three times to start and then will shutdown throwing an error code. This type of shutdown is considered a soft shutdown and can be disabled by accessing the service mode. When entering the service mode, acknowledgment checking is disabled allowing the set to start in the service mode.

Because IV001 performs all major functions of the set, it is suggested great care be taken when determining a failure with IV001. All supply voltages and pin voltages should be checked prior to replacing IV001.

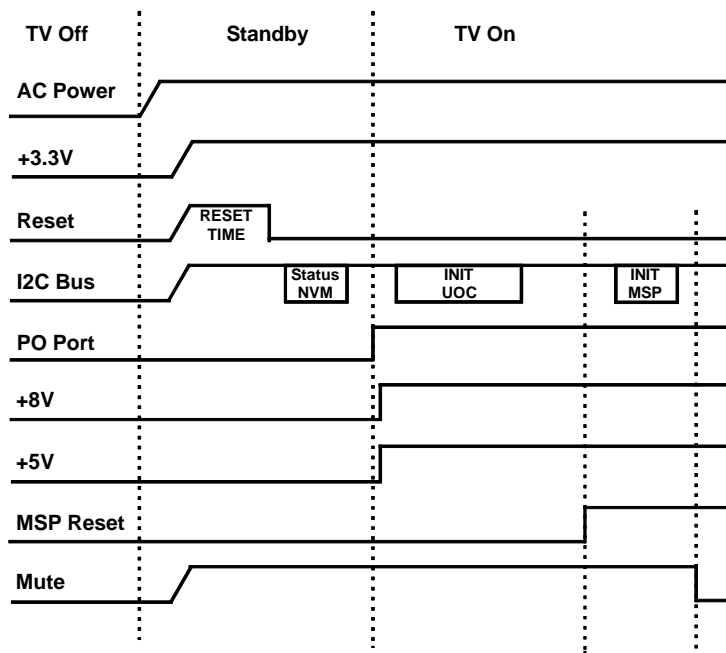

**Power On Timing**

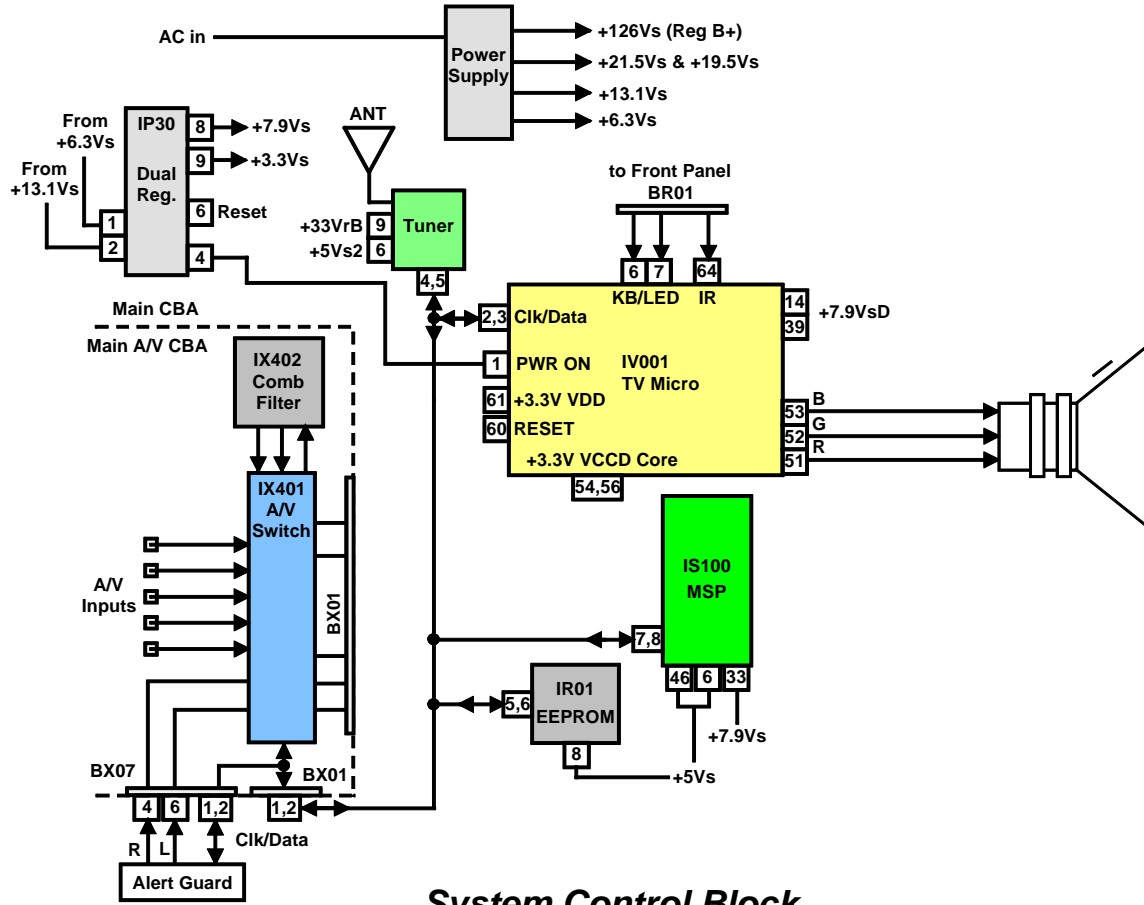

**System Control Block**

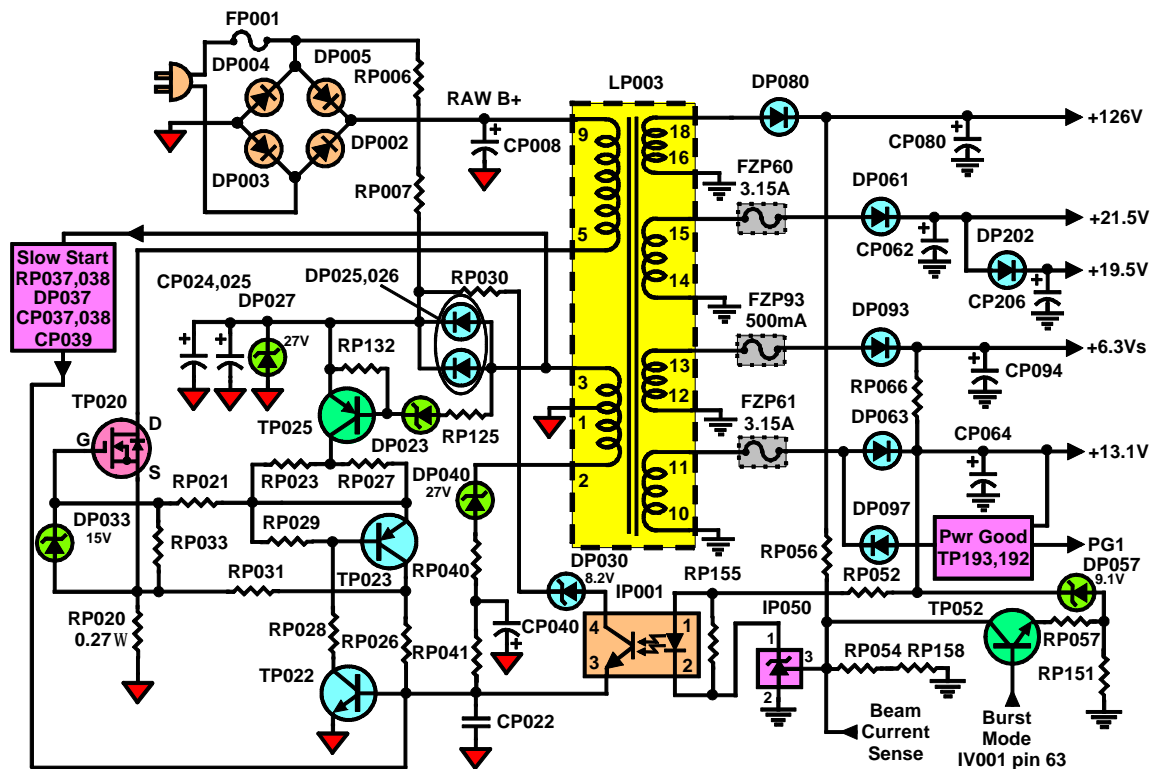

**Power Supply Block**

## Power Supply

The ITC008 power supply is similar to the one used in the TX809 chassis. One major difference is the ITC008 has five (5) major power supplies developed off the secondary of LP003, 126VDC, 21.5Vdc, 13.1Vdc, 19.5Vdc and the 6.3Vdc. Secondary regulation of the 13.1Vdc comes from IP30 dual voltage regulator producing the standby +3.3Vs for system control. See run supply for additional information about the +3.3Vs.

Raw B+ (150VDC) is generated by a full wave bridge rectifier (DP002/3/4/5) and is applied to LP003, pin 9 that serves as the B+ source for the output transistor TP020. Output transistor TP020 provides the drive to transformer LP003. The oscillator driver circuit consists of transistors TP022, TP023 and TP025. The output of the oscillator driver is applied to the gate of TP020 and turns on and off the output transistor. Opto Isolator (IP001) provides the regulation feedback from the secondary side of the supply. IP001 also provides electrical isolation between the primary and secondary side of the supply, isolating the HOT ground from Cold ground.

By tapping a voltage from the bridge rectifier and applying it to the oscillator driver via RP006 and RP007 initial startup is generated. The re-supply or run voltage for the oscillator driver comes from rectifying the pulse at pin 3 of LP003 via DP025 & DP026. The re-supply voltage is coupled back to IP001-4 via Zener DP030 and

serves as B+ for the phototransistor in IP001. The pulse from LP003, pin 3 is also applied to DP023 and is used to trigger the oscillator driver.

Turn off of TP020 occurs when the current through RP020 increases to the trigger point of TP022. Once the voltage drop across RP020 rises to the predetermined trigger point, the oscillator driver turns off, removing drive from TP020. Diode DP040 (27V zener) is used as a protective device to prevent runaway in the event of a failure in the regulation feedback path.

IP050 (precision shunt regulator) controls or regulates IP001 (opto isolator). The voltage applied to pin 3 determines the resistance of IP050. As the voltage on pin 3 of IP50 drops, the resistance decreases. This effectively pulls pin 2 of IP001 closer to ground turning on the photo diode harder. This generates more light and turns on the phototransistor harder. When the phototransistor is turned on harder, this pulls current away from the oscillator driver circuit causing the duty cycle of the power supply to increase (the output device stays on longer). With an increase in duty cycle, the supply outputs more power thus raising the secondary voltages.

There are three inputs to the regulator feedback circuit (IP050, pin 3). First, the 126Vdc is monitored to regulate the standby supply whenever the television is turned on. Second, when the set is turned off but still plugged in, +13.1Vdc is monitored to regulate the power supply via zener DP057 and TP052. During standby (set off) the system control microcomputer (IV001-63) outputs a Burst signal that turns on TP052. The impedance of the standby switch circuit (TP052) is much lower than the run regulation circuit (126Vdc). This allows the standby feedback voltage (+13.1V) to over ride any effect the run feedback voltage (126V) might have. Third, during operation (set on), a beam current sense voltage is applied to pin 3 of IP050. During a high beam current situation, pin 3 of IP050 is pulled down causing pin 1 to fall. This turns on the opto coupler harder which causes the oscillator driver to increase the duty cycle thus pulling up the power supply. This is done to reduce the “breathing” effect during high beam current conditions.

The standby supply has two safety shutdowns. These are over voltage and over current shutdown. Over voltage shutdown occurs if the voltage developed at pin 3 of LP003 rises above 27 volts. Zener DP027 breaks over and shorts removing re-supply and start voltages. Over current protection is provided by RP020 in the source of TP020. Excessive current causes the voltage developed across RP020 to rise hi enough to turn on TP022, again turning TP023 shorting gate drive of TP020 to ground.

The ITC008 also uses circuit protectors (fuses) in the power circuits. The chart on page 30 shows the location and power supply associated with the device.

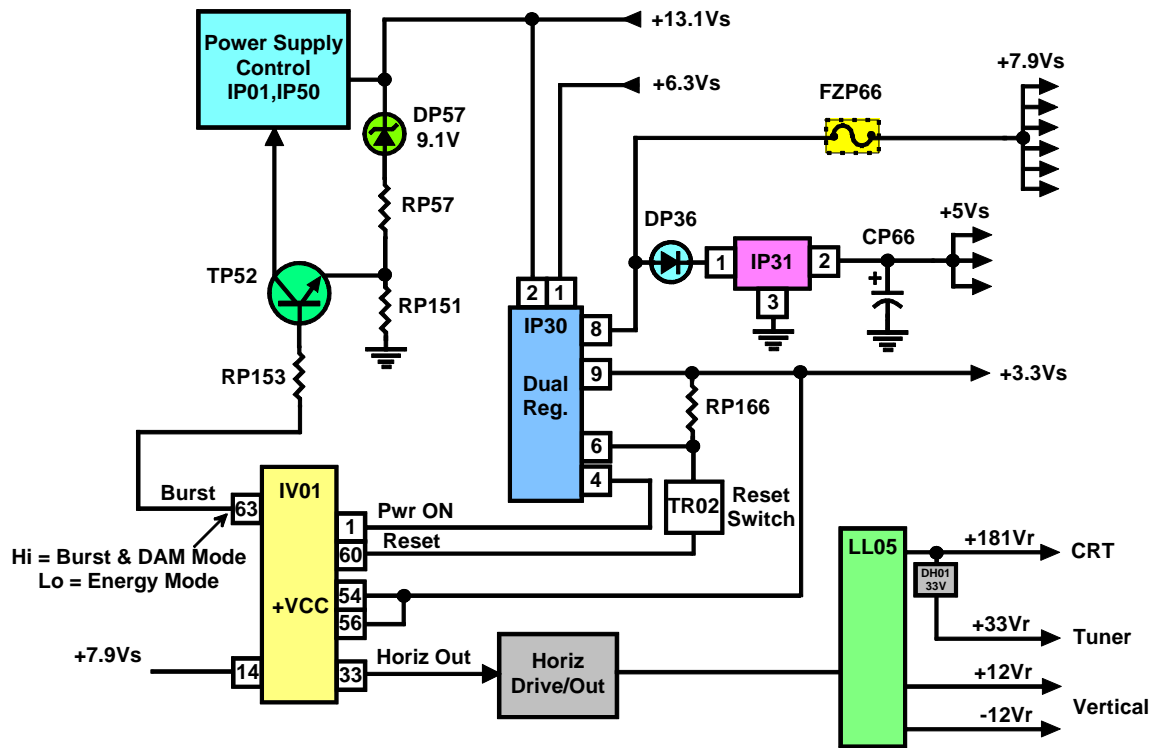

## Switched Power Supply Block

### Switched Power Supply

The switched supply consists of two (2) regulated supplies and four (4) scan derived supplies. The regulated supplies are +7.9Vs and +5Vs. IP30 (dual voltage regulator) produces the +7.9Vs and the +3.3Vs. The +5Vs is derived from IP31 (5V Reg) that is fed by the switched +7.9Vs. The non-switched +3.3Vs from pin 9 of IP30 is active as long as the +6.3Vs is present at pin 1. The +3.3Vs is used for IV01 (System Control) reset (IP30-6) and VCC pin 54,56.

The switched voltage from IP30 pin 8 (+7.9Vs) is activated when pin 4 goes high from the power on (IV01 pin 1). The Burst (High) from IV01-63 turns on TP52 increasing the stand-by supply current to compensate for the additional load during power up.

When IP30 gets the power on signal, +7.9Vs from pin 8 gets applied to pin 14 of IV01 supplying B+ for Horizontal drive. Horizontal drive from IV01 pin 33 drives the driver / Output stage of horizontal. The output stage drives LL05 producing four (4) scan derived supplies. The +181Vr is used for CRT drive and supplying DH001 (33V Zener). DH001 and it's associated circuit produce the tuner voltage +33Vr. Vertical + and - 12Vr are also developed by LL05.



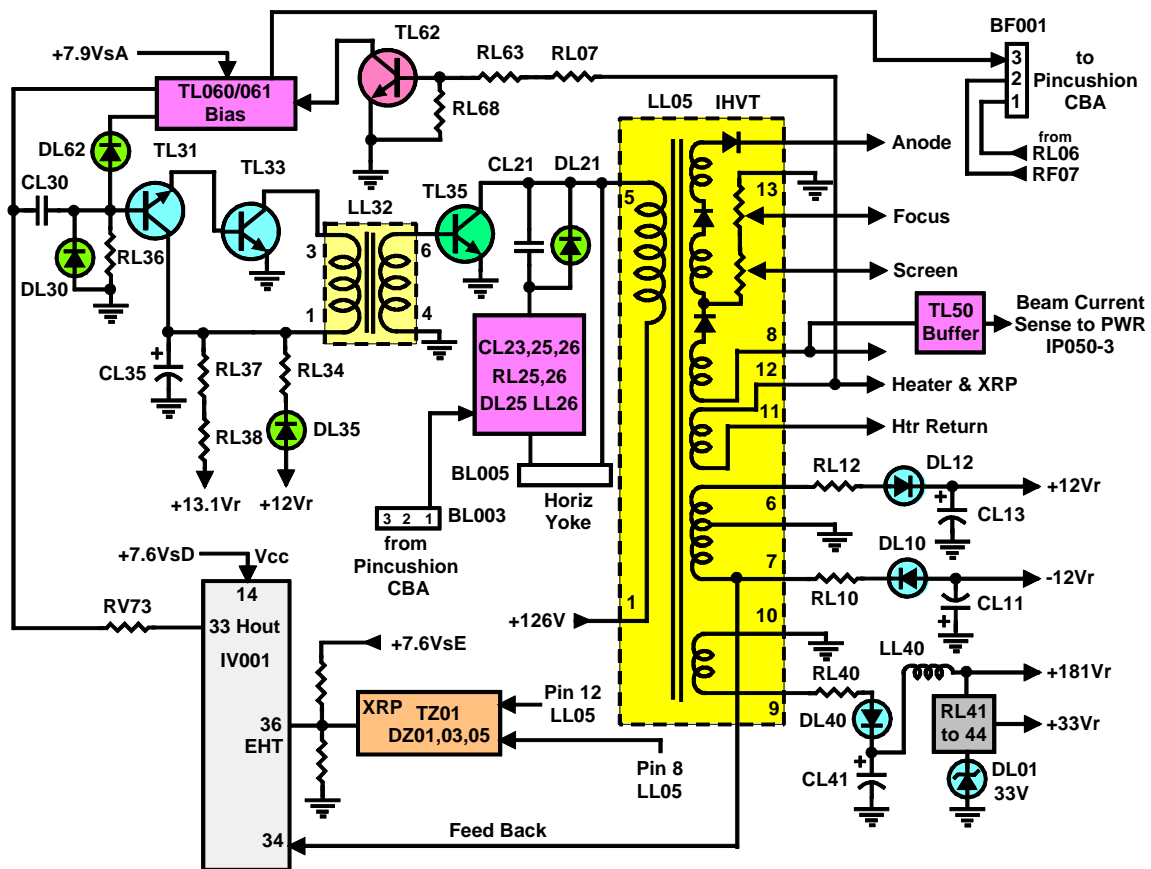

## Horizontal Block

### Horizontal Deflection

Horizontal deflection starts with drive from IV001 pin 33. Drive is produced when the +7.6Vsd is present at pin 14 of IV001. The drive signal is coupled to TL31 via RV73 and CL30. The +13.1Vr provides B+ to TL31 and TL33 until the +12Vr comes up and re-supplies the B+. LL32 couples the drive signal to the output TL35. TL35 drives the fly-back transformer LL05, producing the scan-derived voltages. Feed back from pin 12 of LL05 is used as a slow start bias for TL31 and TL33.

The horizontal output signal is generated by means of an oscillator that is running at 25Mhz and is stabilized with 12Mhz reference. A digital control circuit that is locked to the reference signal of the color decoder determines the free running frequency of the oscillator. When IV001 is switched-on the horizontal output signal is suppressed and the oscillator is calibrated. When all sub-address bytes have been sent via I<sup>2</sup>C bus to IV001 and the frequency of the oscillator is correct, the horizontal drive signal is switched on. To obtain a smooth switching on and switching off of the horizontal output stage, an internal soft start/stop function is used. To protect the horizontal output transistor, the horizontal drive is immediately switched off when a power on reset is detected.

IV001 has a second control loop to guarantee the drive pulse for the horizontal output stage. The horizontal output is gated with the fly-back reference pulse (LFB pin 34), so that the horizontal output transistor cannot be switched on during that time.

All geometry alignments are done via I<sup>2</sup>C bus commands except E/W alignment. X-ray protection is activated via EHT tracking (IV001 pin 36) when the level exceeds +3.9V. If the level exceeds +3.9V at pin 36, horizontal drive will be stopped at pin 33 shutting down horizontal drive and the set.

The horizontal drive output is an open collector configuration. Thus an AC coupled Darlington driver (TL31 and TL32) is used. Before startup, the capacitor CL35 is charged by +13.1Vr via RL37 and RL38. When the H drive signals are starting the T-on time is very short and the energy stored in CL35 is enough to supply the driver. Because the +12Vr supply is generated in forward mode the first pulses charge CL13. Once CL13 is charged the supply voltage for the driver is coming from the +12Vr via DL35 and RL 34.

### **E/W Correction**

An external E/W correction-driving signal is produced by making use of synchronized vertical feedback signal derived from RF07 off pin 2 of BF001. The saw tooth is amplified and inverted before being fed into an integrator (IL101) to generate a parabola signal. PL141 acts as an E/W amplitude control by controlling the parabola signal amplitude. PL140 is part of the voltage divider that determines the DC level used for horizontal size alignment. The horizontal breathing is controlled by the beam current information via RL150 to the DC level biasing at PL140. The trapezium alignment is achieved by introducing the inverted saw tooth waveform to the parabola output signal.

A safety circuit RL112, RL113, DL113 DL114, CL110, CL114, CL123, RL110, DL117, DL118, RL117, RL118, and DL119 is to inhibit the H-drive and shut down the deflection circuit in the case of TL101 failure.

A diode modulator (DL21, CL21 (main CBA), DL121, DL122 and CL122 (Pincushion CBA) is used to modulate the horizontal deflection current with vertical frequency in order to obtain higher amplitude of deflection current in the middle and smaller amplitude on the top and bottom of the raster.

The resonant frequency LC product of bridge coil LL122 and CL122 in series connected with CL123 is the same as the product of tuning capacitor CL21 together with the deflection yoke. The capacitive divider CL21 and CL122 produces a retrace voltage across CL122. The integrated value of this voltage is corresponded by the

voltage across CL123. A maximum voltage across CL123 means the deflection current is minimal and vice versa.

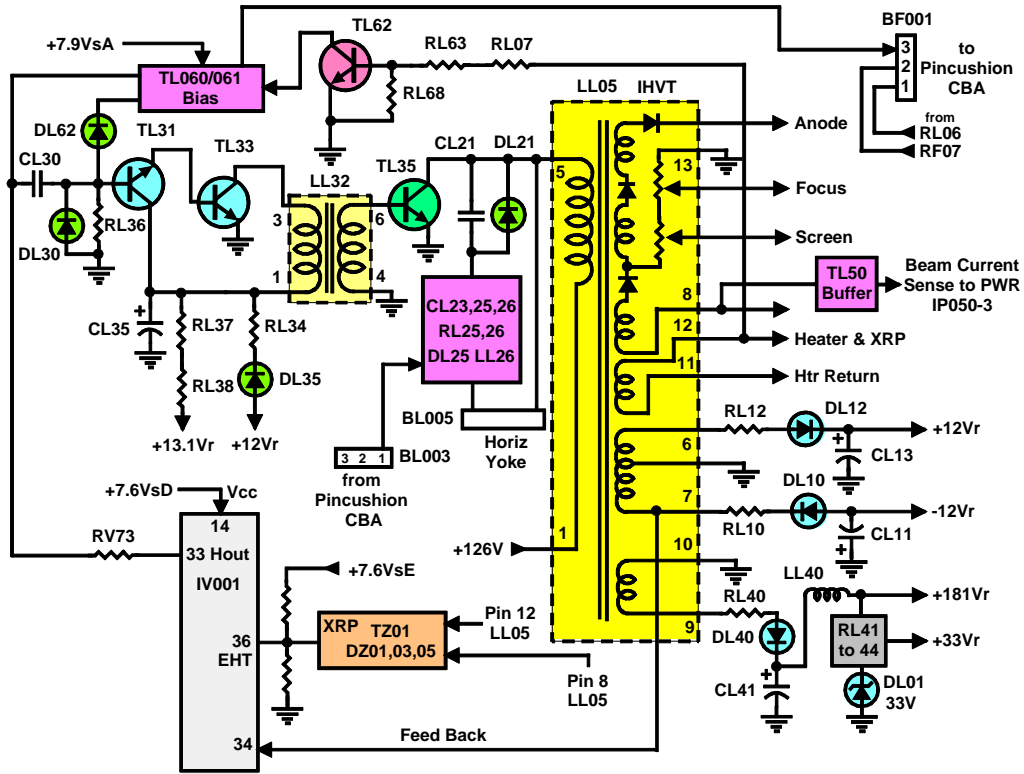

**Horizontal Block**

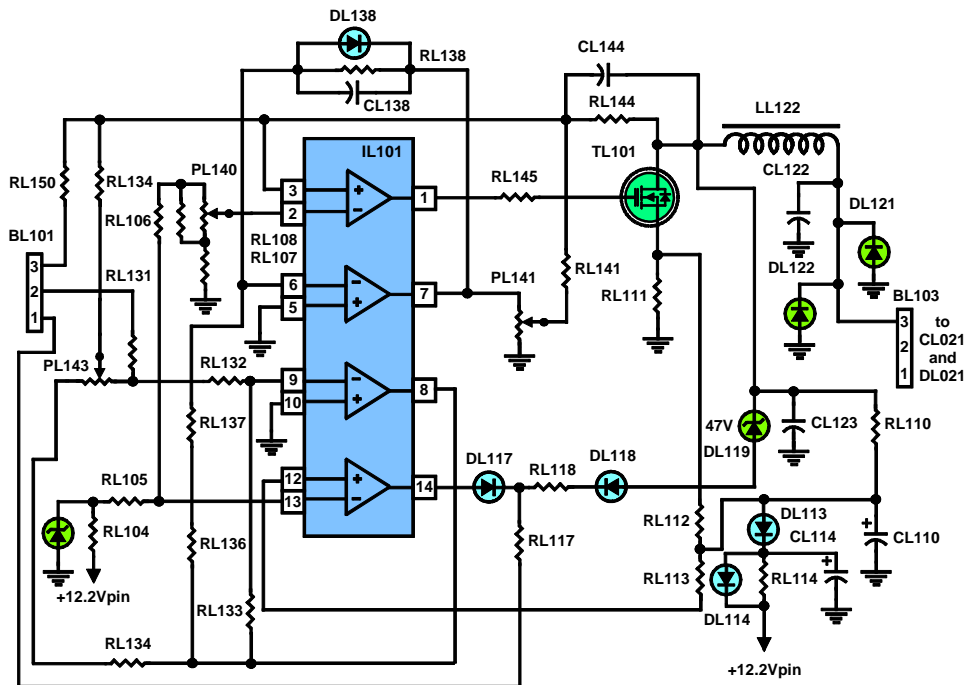

**E/W Correction Block**

## Vertical Deflection

The ITC008 vertical deflection circuit consists of vertical ramp generator in IV001 processor and a power stage IF001. The vertical ramp generator is in the TV processor IV001. The geometry parameters can be adjusted via the I<sup>2</sup>C bus to control TV processor IV001. Four parameters Vertical Slope, Vertical Amplitude, Vertical Shift and S Correction are all controlled by software.

The power stage, IF001, is configured as differential amplifier and driven by the ramp current delivered by IV001 pin 21 and pin 22. The vertical ramp current ( $I_r$ ) is imposed on the V-drive signals. So we have  $I+I_r$  and  $I-I_r$  from pin 21 and pin 22 respectively.

The fly-back supply voltage on pin 5 is  $2 \times V_{supply} + |-V_{supply}|$  and the maximum scanning supply voltage on pin 5 is  $V_{supply}$  or  $-V_{supply}$ . Pin 3 voltage is at  $-V_{supply}$  and CF10 is charged to  $V_{supply} + |-V_{supply}|$  during scanning period. The fly-back generator switches pin 3 to  $V_{supply}$ . Thus the total fly-back supply voltage is:  $2 \times V_{supply} + |-V_{supply}|$ .

CF08/09-RF08 is the zero-pole compensation to increase the phase margin of the amplifier while still maintaining expected bandwidth. RF08 is a fusible resistor to prevent overheating in the event of CF08/09 failure. This circuit also helps to protect the IC during picture tube arcing. DF01 also protects the vertical IC during picture tube arcing.

Resistor RF09 damps spurious oscillation in the VDC and reduces crosstalk from the HDC into the VDC.

RF07 is a current sensing resistor. The deflection current is proportional to the output voltage across RF07.

RF101, DF101, DF102, RF102 and CF101 act as a protection circuit to pull down the Beam Current Limit path as to suppress the video amplitude during vertical booster IC failure. This prevents CRT screen phosphor from burning by intense white line.

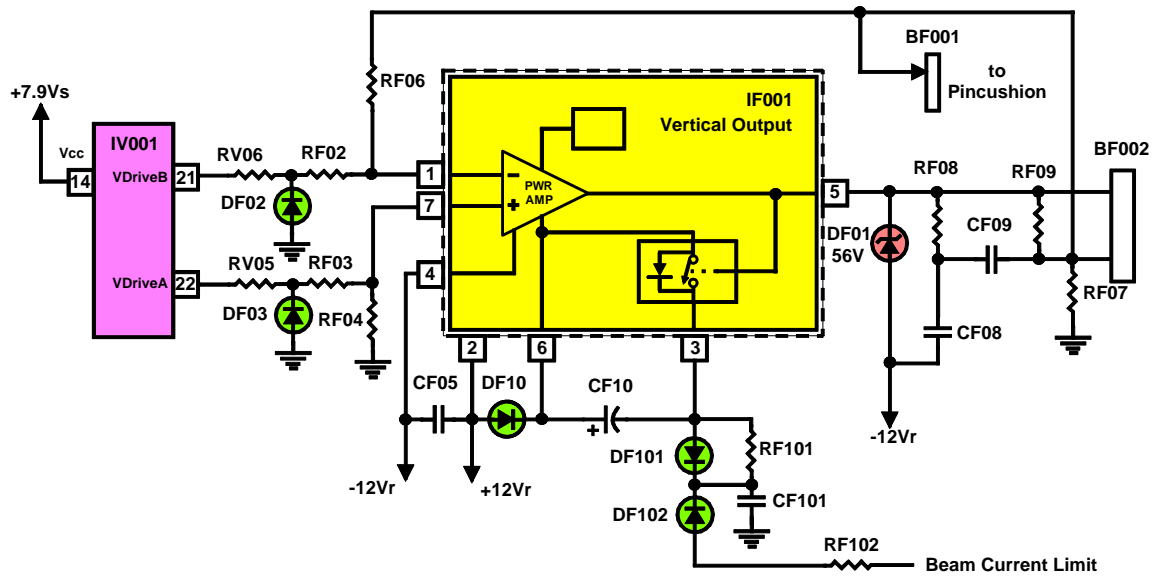

**Vertical Block**

## Shutdown

The ITC008 is a basic chassis with a few protection fuses and a shutdown circuit.

Shutdown consists of an XRP circuit that monitors the heater pulse from pin 12 of LL05. A detector circuit consisting of DZ01, DZ03, DZ05, and 1% resistors (RZ05 and RZ07) determine the trip point of TZ01. If the heater pulse is too high, TZ01 turns on increasing the voltage at pin 36 of IV001 (>3.9Vdc). IV001 in turn shuts down horizontal drive turning off the set.

Aside from the above listed shutdown the ITC008 also uses circuit protectors (fuses) in the power circuits. The below chart shows the location and power supply associated with the device.

Device (Open)	Reg B+	High Voltage	Video	Audio	Comments
<b>FP01 (AC Fuse)</b> Main CBA	0Vdc	NO	NO	NO	DEAD
<b>FZP60 (+21.5V)</b> Main CBA	132Vdc	YES	YES	NO	Set comes on with No Audio
<b>FZP61 (+13.1V)</b> Main CBA	0Vdc	NO	NO	NO	DP27 Shorts (Over Voltage protect)
<b>FZP66 (+7.9V)</b> Main CBA	132Vdc	NO	NO	NO	Cycles when Power is pushed
<b>FZP93 (+6.3V)</b> Main CBA	125Vdc	NO	NO	NO	Dead, Power supply working
<b>FZK001 (+13.1V)</b> Alert Guard	132Vdc	NO	NO	NO	Dead, Disconnect Alert Guard module and set powers on with video and audio.
<b>FZX001 (+12V)</b> MAV	128Vdc	YES	NO	Yes	OSD present on channel change

**Circuit Protection Chart**

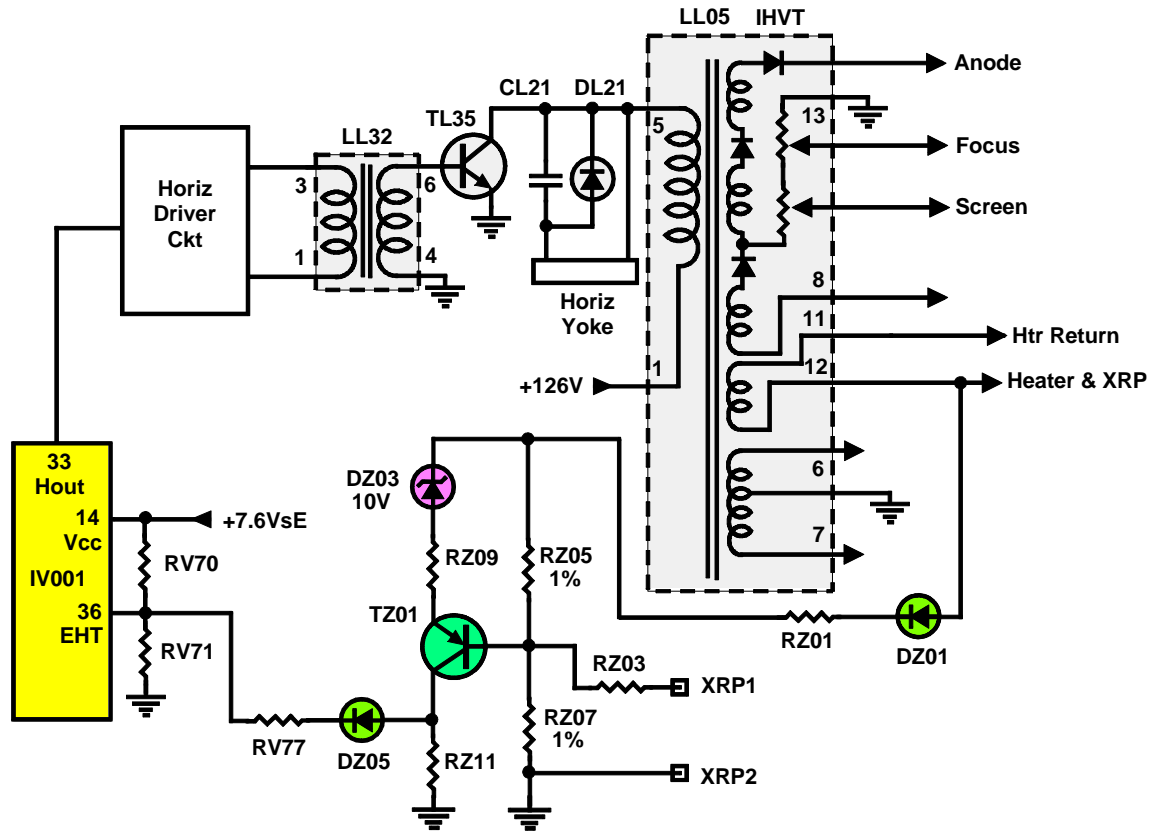

**XRP Block**

## Troubleshooting Section

### Dead Set Troubleshooting

**Symptom:** Nothing happens when power is pushed, set is dead.

**NOTE 1:** DP027 will short during over voltage, shutting down the power supply. IF DP027 is shorted, check FZP61. If FZP61 is open, check the +13V for excessive load. A loss of feedback will cause over voltage condition.

**NOTE 2: Disconnect Alert Guard CBA. A problem with alert guard can cause the set to appear dead!**

1. Check RAW B+, if not OK check the full wave bridge rectifier DP002/003/004/005 and it's associated components.
2. If RAW B+ OK, check the current sensing resistor RP020. If open, this indicates there has been a severe over current condition in the power supply and all active components on the primary side of LL003 should be checked and replaced (**See note 3 in step 6**).
3. Check DC voltage and waveform on the gate of TP020. This will indicate if the oscillator is running and the power supply is working.
4. If there is no waveform on the gate of TP020, unsolder the drain of TP020 and check for 7.9Vdc on the gate. 7.9Vdc on the gate of TP020 indicates start-up circuit is working go to step 6. If waveform present on the gate of TP020, the power supply is working, troubleshoot system control.
5. If DC on gate of TP020 is not 7.9Vdc, check TP025, DP027, DP023, RP006, and RP007 (start up circuit) and replace if suspect.
6. If no waveform on gate of TP20 (DC OK), check TP22, TP23 and their associated components. Replace all transistors if one has failed or is suspect.

**NOTE 3: If TP020 has failed more than likely the other transistors have been stressed and the circuit will self-destruct again when plugged into 120 AC unless all active components are replaced.**

7. If TP020 checks OK (with primary circuit pulsing), check IP01 (Ref Reg) and IP50 (Opto Coupler) and their associated components.





## Shutdown Troubleshooting

**Symptom:** Set is pulsing when power is pushed wont start.

**NOTE:** Using Chipper Check, check for error codes. This will indicate which device maybe causing the shutdown.

Remember to **ALWAYS** reset the error codes and allow the set to cycle again to obtain a current error code reading.

**Disconnect Alert Guard CBA. A problem with alert guard can cause the set to appear dead!**

1. With the set plugged into AC power check for +126Vdc on TL035-C horizontal output transistor. If missing see dead set troubleshooting, if present, power supply is working.
  2. Push the power switch, if set pulses then system control is working.
  3. With set pulsing, check for horizontal drive at pin 33 of IV001. If not present suspect IV001 and it's associated circuits.
  4. Waveform present at pin 33 of IV001 indicates IV001 and system control are working and problem is in the horizontal circuit. Troubleshoot horizontal circuit.
-

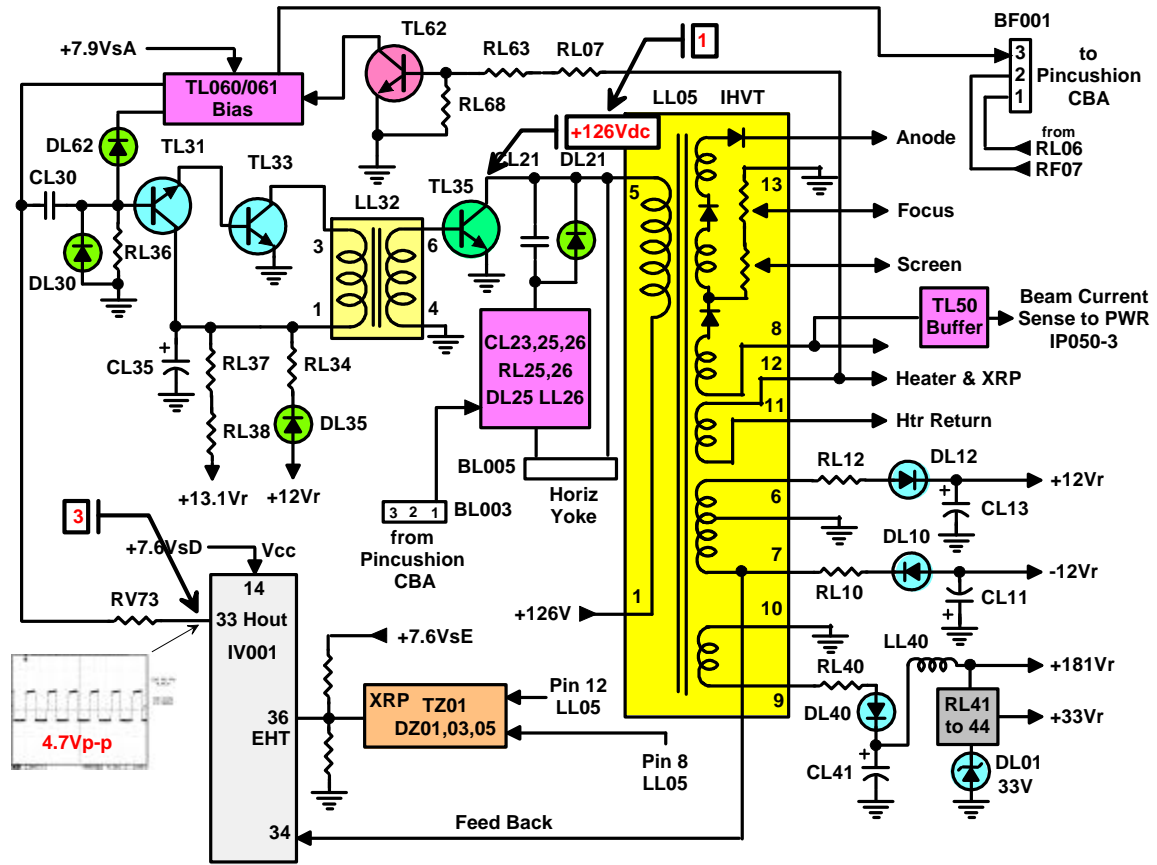

**Horizontal Block**

## Horizontal Troubleshooting

**Symptom:** No high voltage horizontal wont start

1. Unsolder collector of TL35 (HOT).
2. Monitor the base of TL35 and push the power switch. The set will cycle until power is pushed again and a horizontal pulse will be present at the base of TL35 while it is cycling.
3. If pulse is present on the base of TL35, IV001 and the driver circuit is working. The problem is off the collector of TL35. Suspect Yoke, Yoke return circuit, pincushion, LL05 and the secondary side of LL05.
4. If pulse is missing or set won't cycle suspect IV001, TL31, TL33, LL32 and their associated circuits.

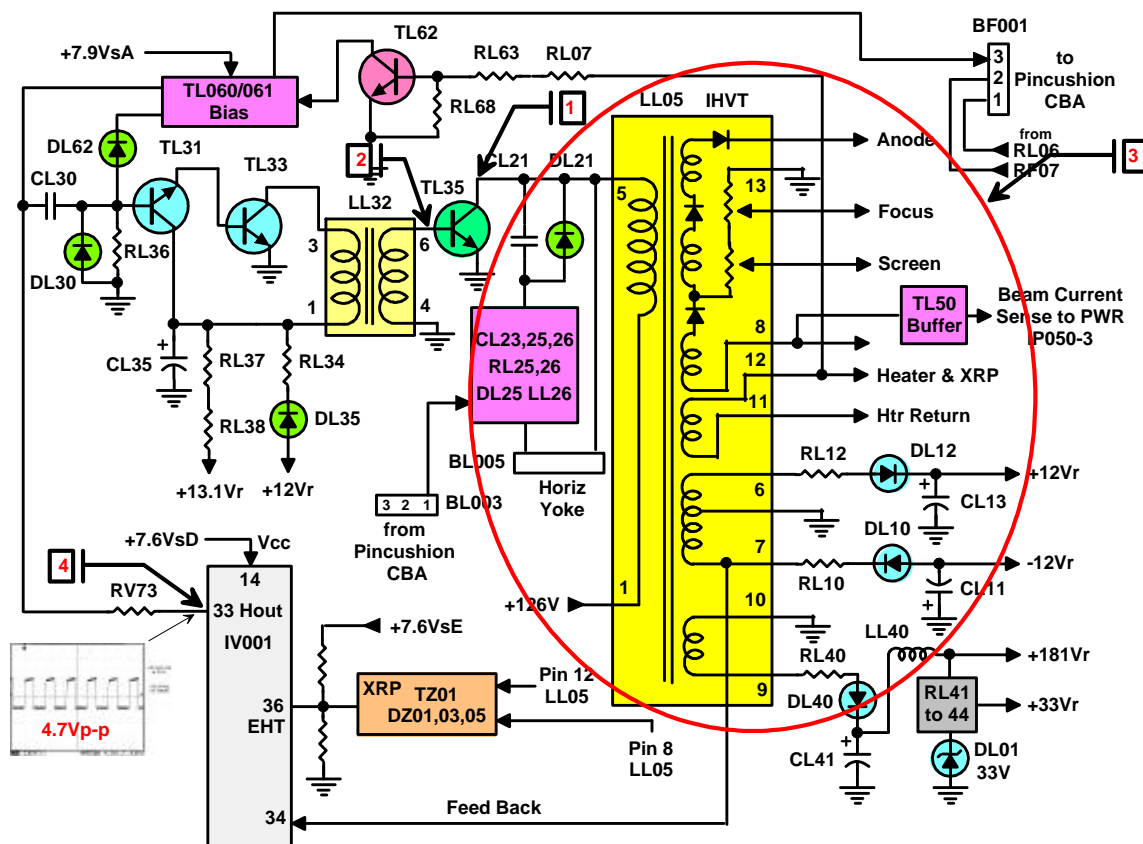

**Horizontal Block**

## System Control Troubleshooting

**Before replacing IV001 these series of checks need to be performed.**

1. Check DC voltage on pins 2, 3 (4.5Vdc), 54, 56, 58, 59, 61(3.3Vdc) and 61 (0Vdc). These pins are used for system control function. If missing troubleshoot the appropriate circuit area.
2. Check pins 6, 7, and 64 for 3.3Vdc. These pins are user interface inputs. If missing or low troubleshoot the appropriate circuit area.
3. Check pins 12, 18, 30, 41, and 57 for ground. Improper ground to IV001 can cause erratic operation.

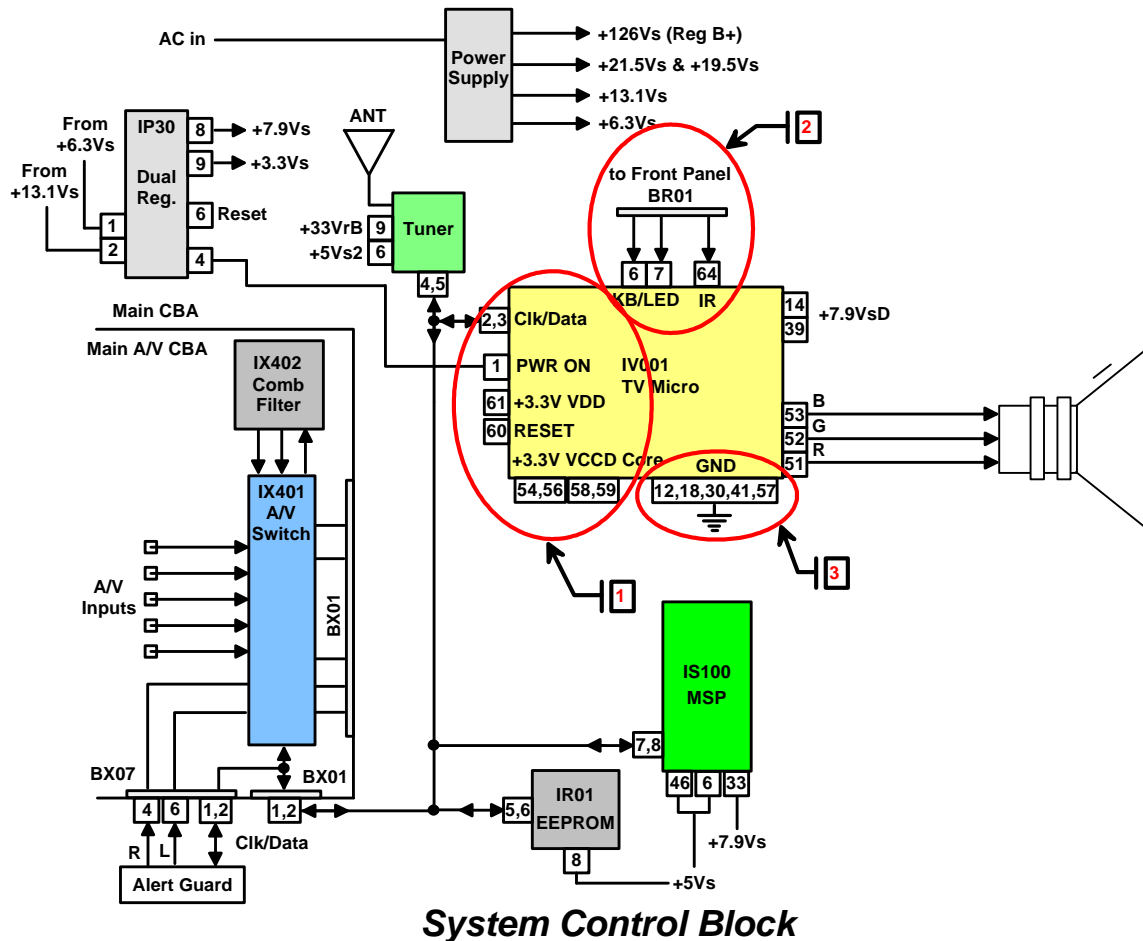

**System Control Block**



# THOMSON