

ITR-H-0111 PHOTOINTERRUPTER

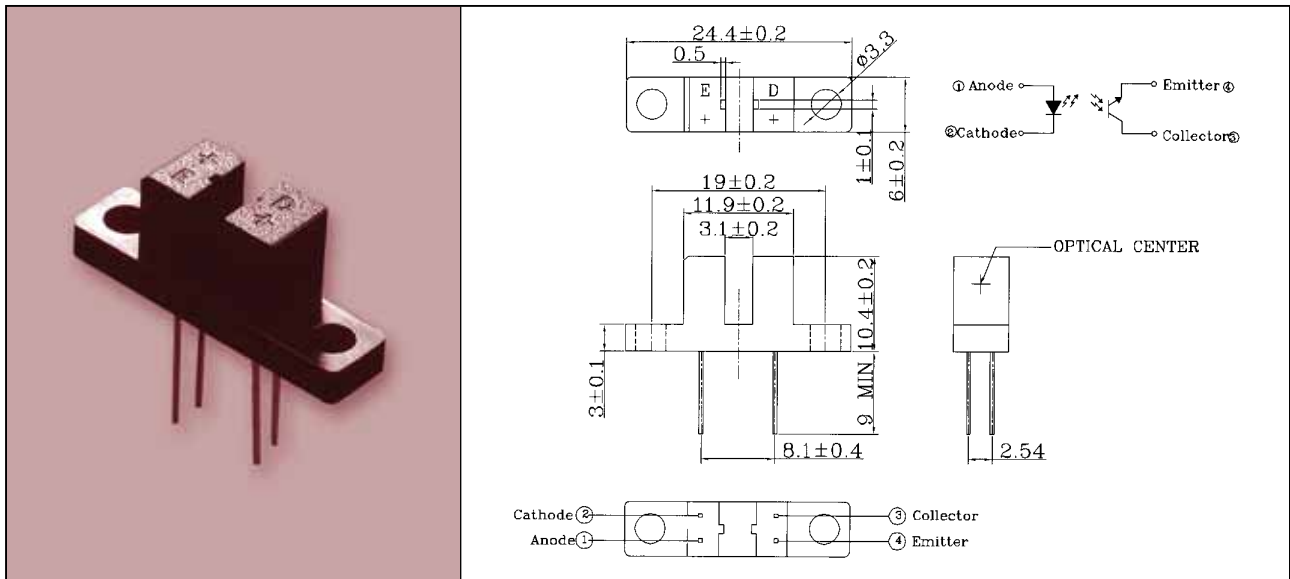

◆ABSOLUTE MAXIMUM RATING:(Ta=25°C)

	Symbol	Parameter	Max	Unit
Input	Pd	Power Dissipation	60	mW
	VR	Reverse Voltage	5	V
	IF	Forward Current	50	mA
Output	Pd	Power Dissipation	10	mW
	IC	Collector Current	20	mA
	VCEO	Collector-Emitter Voltage	30	V
Topr		Operating Temperature Range	-20°C to 85°C	
Topr		Emitter-Collector Voltage	-20°C to 85°C	

Lead Soldering Temperature {1.6mm(0.063 inch)From Body}250°C ±5°C For 3 Seconds

◆ELECTRO-OPTICAL CHARACTERISTICS:(Ta=25°C)

	Symbol	Parameter	Conditions	Min	Typ	Max	Unit
Input	VF	Forward Voltage	IF=20mA	-	1.2	1.6	V
	IR	Reverse Current	VR=5V	-	-	10	μ A
	λ P	Peak Wavelength	IF=20mA	-	940	-	nm
Output	ICEO	Collector Dark Current	VCE=20V Ee=0mW/cm ²	-	-	100	nA
	VCE(sat)	C-E Saturation Voltage	IC=5V IF=20mA	-	-	0.4	V
Ic (ON)		Collector Current	VCE=5V IF=20mA	1	4	-	mA
Speed	tR; tF	Rise/Fall Time	VCE=5V IC=1mA RL=1000 Ω	-	15/15	-	μ S

1.All dimension are in millimeters(inches).

2.Tolerance is ±0.25mm(0.01")unless otherwise specified.