

N-Channel MOSFET

Lead Free Package and Finish

Applications:

- Adaptor
- Charger
- SMPS

V_{DSS}	$R_{DS(ON)}(Typ.)$	I_D
700V	0.96Ω	7A

Features:

- RoHS Compliant
- Low ON Resistance
- Low Gate Charge
- Peak Current vs Pulse Width Curve
- Inductive Switching Curves

Ordering Information

PART NUMBER	PACKAGE	BRAND
ITU07N70R	TO-251	IPS

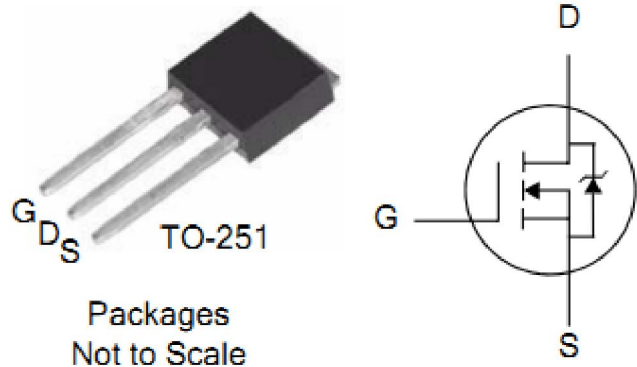

Absolute Maximum Ratings $T_C=25^\circ\text{C}$ unless otherwise specified

Symbol	Parameter	ITU07N70R	Units
V_{DSS}	Drain-to-Source Voltage	700	V
I_D	Continuous Drain Current	7	A
	Continuous Drain Current $T_C = 100^\circ\text{C}$	4.4	A
I_{DM}	Pulsed Drain Current (NOTE *1)	28	A
P_D	Power Dissipation	120	W
	Derating Factor above 25°C	0.96	W/ $^\circ\text{C}$
V_{GS}	Gate-to-Source Voltage	± 30	V
E_{AS}	Single Pulse Avalanche Energy(NOTE *2)	480	mJ
dv/dt	Peak Diode Recovery dv/dt(NOTE *3)	5	V/ns
T_L	Maximum Temperature for Soldering	300	$^\circ\text{C}$
T_J and T_{STG}	Operating Junction and Storage Temperature Range	150, -55 to 150	

Thermal Resistance

Symbol	Parameter	Typ.	Units	Test Conditions
$R_{\theta JC}$	Junction-to-Case	1.04	$^\circ\text{C/W}$	Water cooled heatsink, P_D adjusted for a peak junction temperature of $+150^\circ\text{C}$.
$R_{\theta JA}$	Junction-to-Ambient	100		1 cubic foot chamber, free air.



OFF Characteristics $T_C=25^\circ\text{C}$ unless otherwise specified

Symbol	Parameter	Min.	Typ.	Max.	Units	Test Conditions
BV_{DSS}	Drain-to-Source Breakdown Voltage	700	--	--	V	$V_{GS}=0V, I_D=250\mu A$
I_{DSS}	Drain-to-Source Leakage Current	--	--	10	μA	$V_{DS}=700V, V_{GS}=0V$ $T_J=25^\circ\text{C}$
		--	--	100		$V_{DS}=560V, V_{GS}=0V$ $T_J=125^\circ\text{C}$
I_{GSS}	Gate-to-Source Forward Leakage	--	--	+100	nA	$V_{GS}=+30V$
	Gate-to-Source Reverse Leakage	--	--	-100		$V_{GS}=-30V$

ON Characteristics $T_J=25^\circ\text{C}$ unless otherwise specified

Symbol	Parameter	Min.	Typ.	Max.	Units	Test Conditions
$R_{DS(ON)}$	Static Drain-to-Source On-Resistance	--	0.96	1.15	Ω	$V_{GS}=10V, I_D=3.5A$
$V_{GS(TH)}$	Gate Threshold Voltage	2	--	4	V	$V_{DS}=V_{GS}, I_D=250\mu A$
g_{fs}	Forward Transconductance	--	7.5	--	S	$V_{DS}=15V, I_D=3.5A$
Pulse width $\leq 300\mu s$; duty cycle $\leq 2\%$						

Dynamic Characteristics Essentially independent of operating temperature

Symbol	Parameter	Min.	Typ.	Max.	Units	Test Conditions
C_{iss}	Input Capacitance	--	1556	--	μF	$V_{GS}=0V, V_{DS}=25V$ $f=1.0\text{MHz}$
C_{oss}	Output Capacitance	--	115	--		
C_{rss}	Reverse Transfer Capacitance	--	4.7	--		
Q_g	Total Gate Charge	--	26.5	--	nC	$I_D=7A, V_{DD}=560V$ $V_{GS}=10V$
Q_{gs}	Gate-to-Source Charge	--	6.3	--		
Q_{gd}	Gate-to-Drain ("Miller") Charge	--	9.6	--		

Resistive Switching Characteristics Essentially independent of operating temperature

Symbol	Parameter	Min.	Typ.	Max.	Units	Test Conditions
$t_{d(ON)}$	Turn-on Delay Time	--	24	--	ns	$V_{DD}=350V, I_D=7A,$ $V_G=10V, R_G=10\Omega$
t_{rise}	Rise Time	--	17	--		
$t_{d(OFF)}$	Turn-Off Delay Time	--	47	--		
t_{fall}	Fall Time	--	18	--		

Source-Drain Diode Characteristics Tc=25°C unless otherwise specified

Symbol	Parameter	Min.	Typ.	Max.	Units	Test Conditions
I_S	Continuous Source Current (Body Diode)	--	--	7	A	$T_C=25^\circ\text{C}$
I_{SM}	Maximum Pulsed Current (Body Diode)	--	--	28	A	
V_{SD}	Diode Forward Voltage	--	--	1.5	V	$I_{SD}=7\text{A}, V_{GS}=0\text{V}$
t_{rr}	Reverse Recovery Time	--	382	--	ns	$I_F=I_S$ $di/dt=100\text{A/us}$
Q_{rr}	Reverse Recovery Charge	--	2360	--	nC	
Pulse width $\leq 300\mu\text{s}$; duty cycle $\leq 2\%$						

Notes:

- *1. Repetitive rating; pulse width limited by maximum junction temperature.
- *2. $L=10\text{mH}$, $I_D=9.8\text{A}$, Start $T_J=25^\circ\text{C}$
- *3. $I_{SD}=7\text{A}$, $di/dt \leq 100\text{A/us}$, $V_{DD} \leq BV_{DS}$, Start $T_J=25^\circ\text{C}$

Characteristics Curve:

Figure 1. Maximum Effective Thermal Impedance, Junction-to-Case

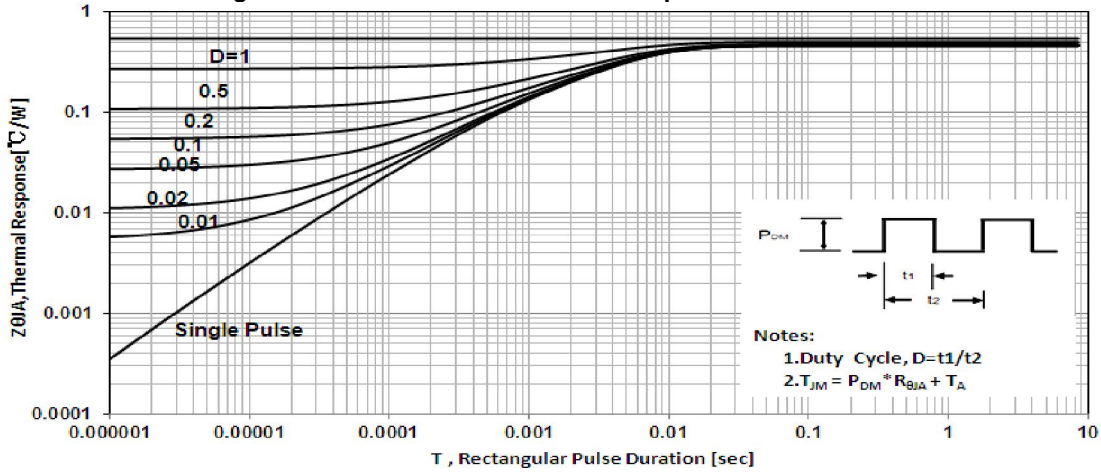

Figure 2. Max. Power Dissipation vs Case Temperature

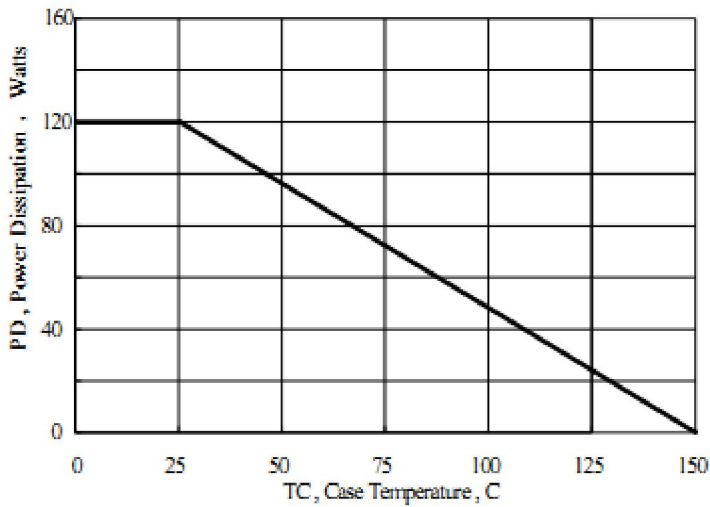

Figure 3. Max. Drain Current vs Case Temperature

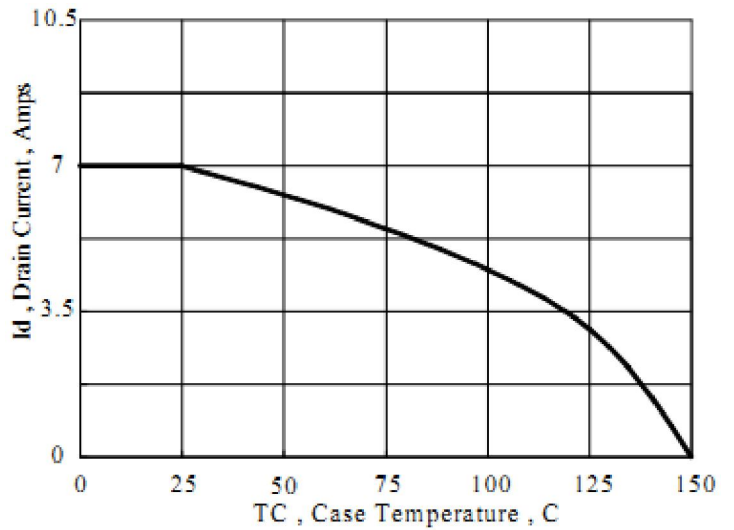

Figure 4. Typical Output Characteristics

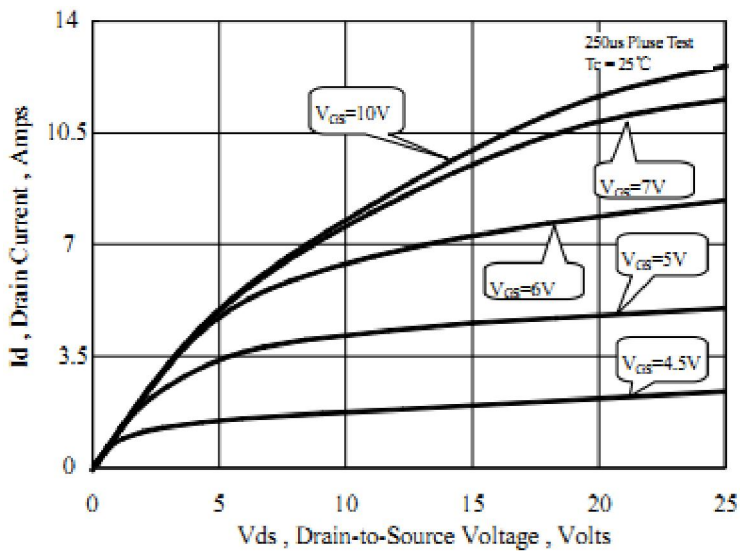

Figure 5. Typical Transfer Characteristics

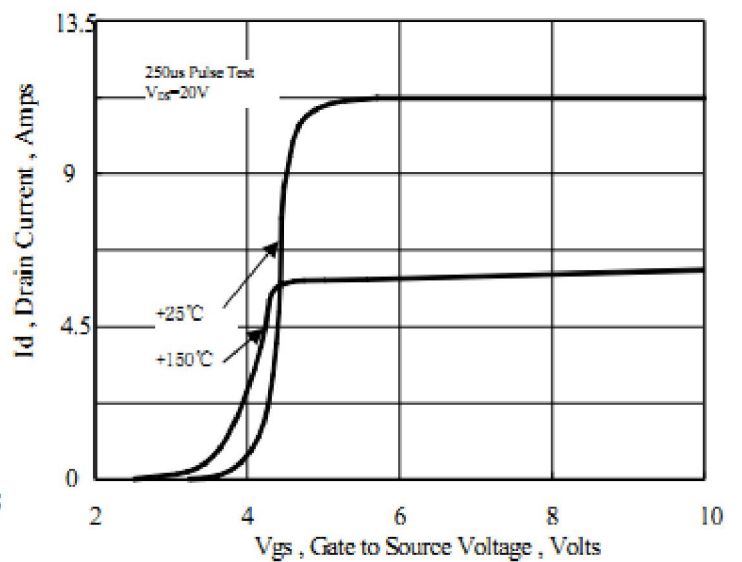

Figure 6. Typical Body Diode Transfer Characteristics

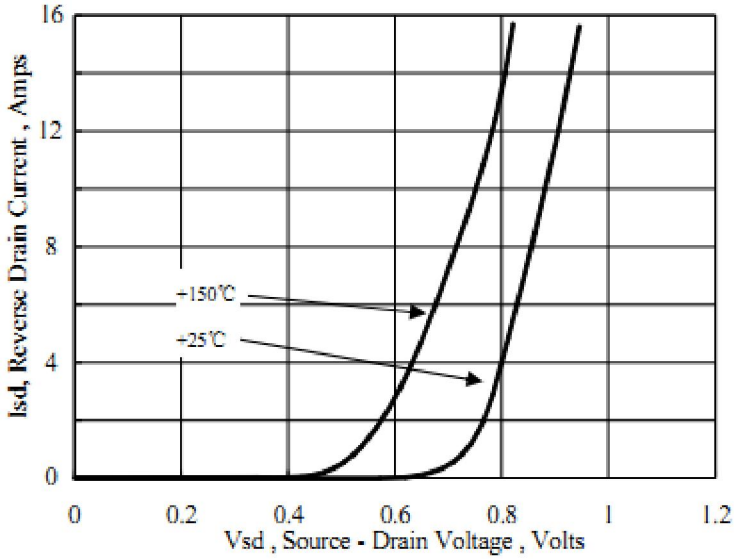

Figure 7. Typical on Resistance VS Drain Current

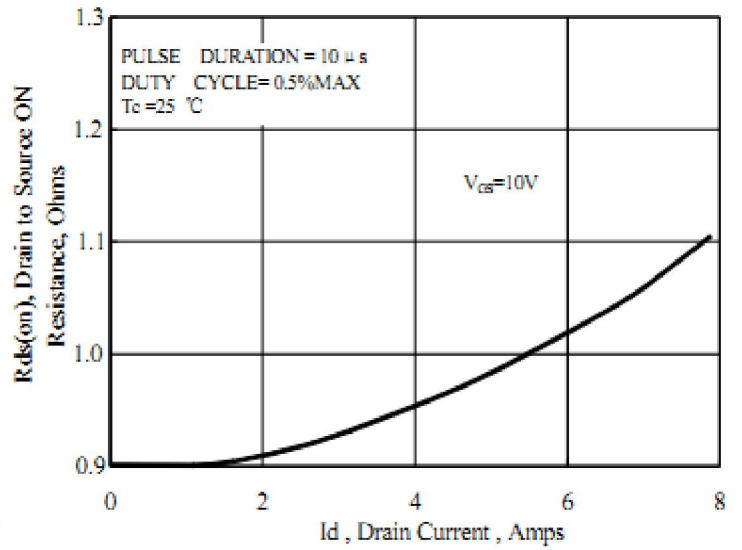

Figure 8. Capacitance VS Drain-to-Source Voltage

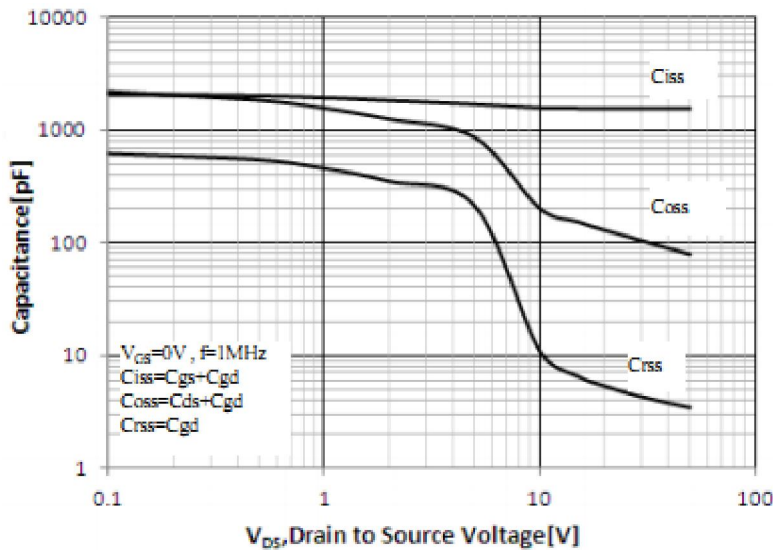

Figure 9. Gate Charge VS Gate-to-Source Voltage

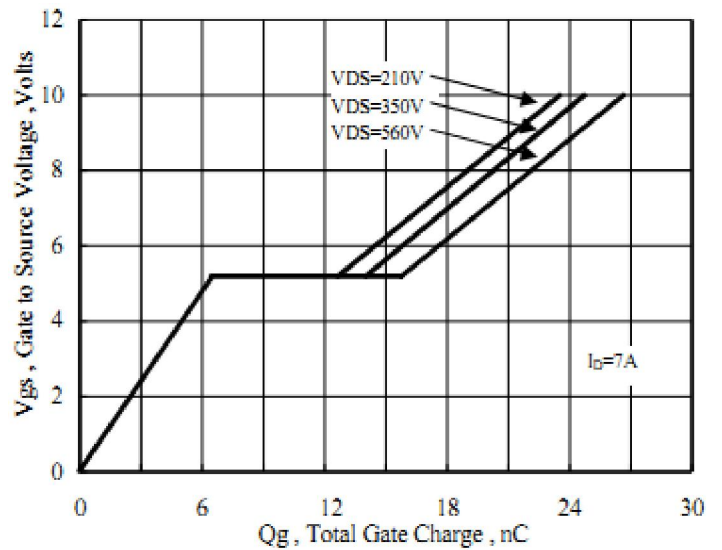

Figure 10. Breakdown Voltage VS Temperature

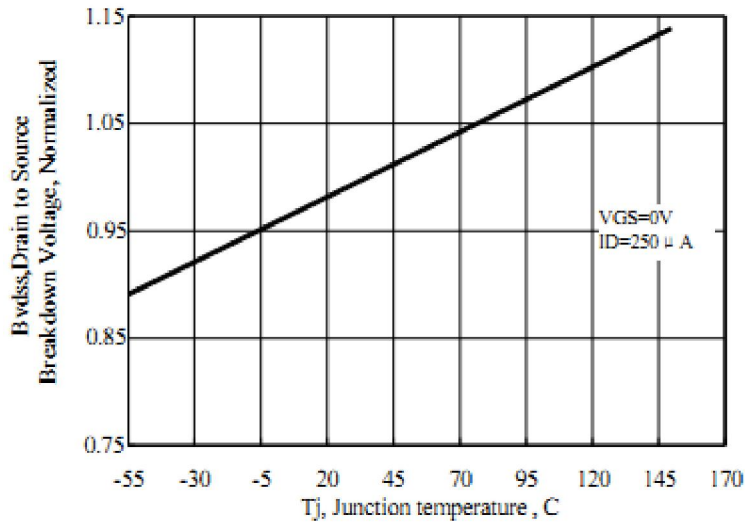

Figure 11. on-Resistance VS Temperature

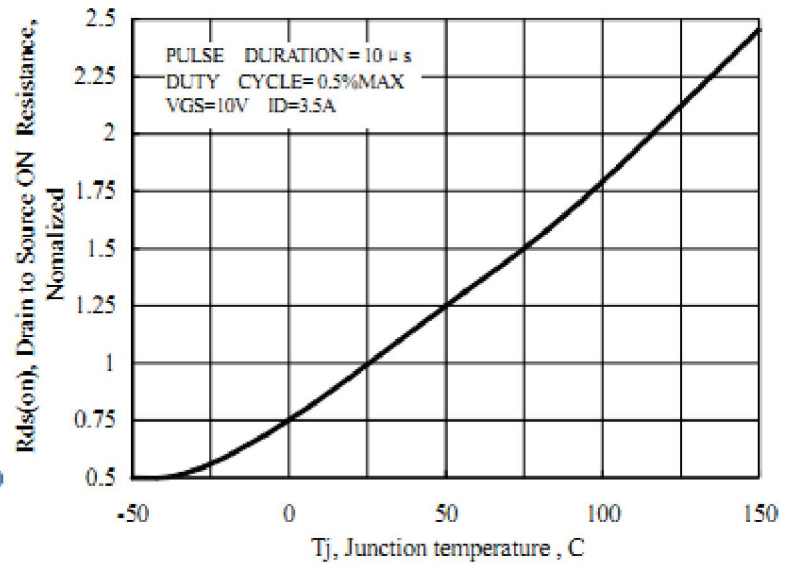

Figure 12 Theshold Voltage vs Junction Temperature

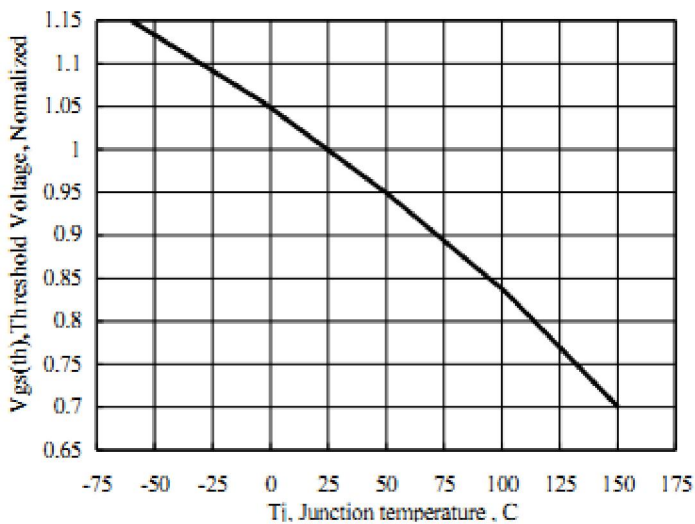
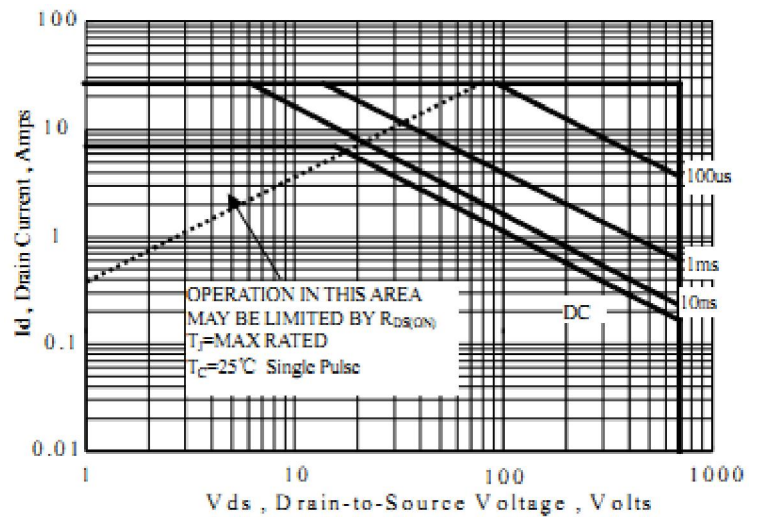

Figure 13. Safe Operating Area



Test Circuits and Waveforms

Figure 14. Gate Charge Test Circuit

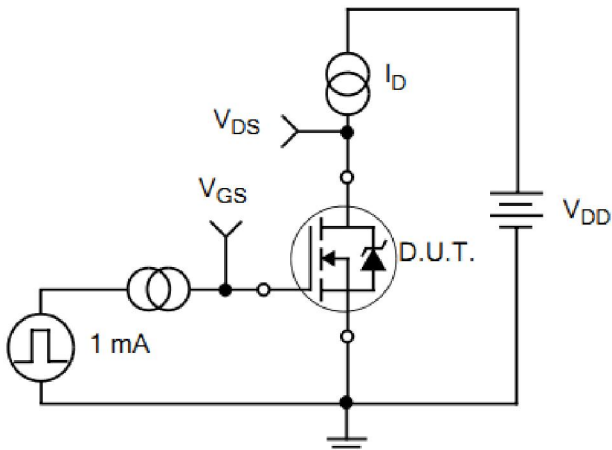

Figure 15. Gate Charge Waveforms

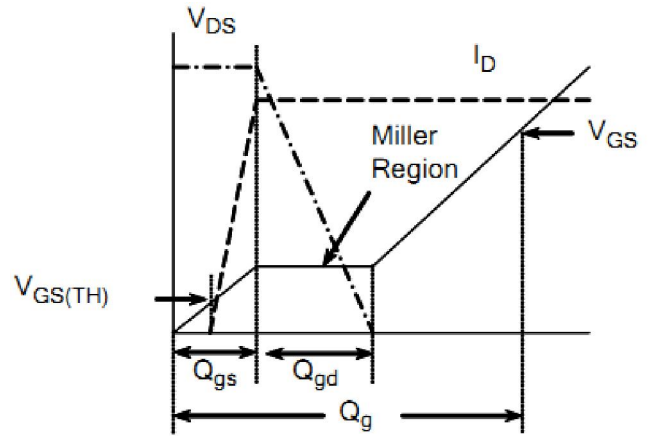

Figure 16. Resistive Switching Test Circuit

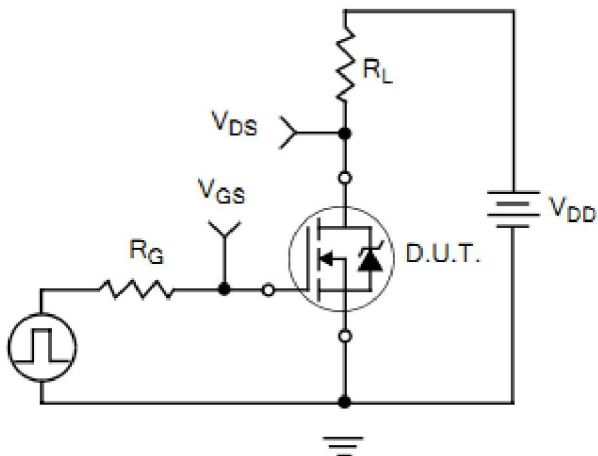

Figure 17. Resistive Switching Waveforms

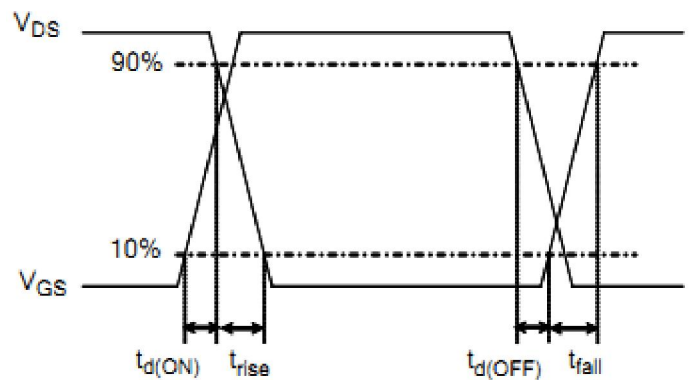

Figure 18. Diode Reverse Recovery Test Circuit

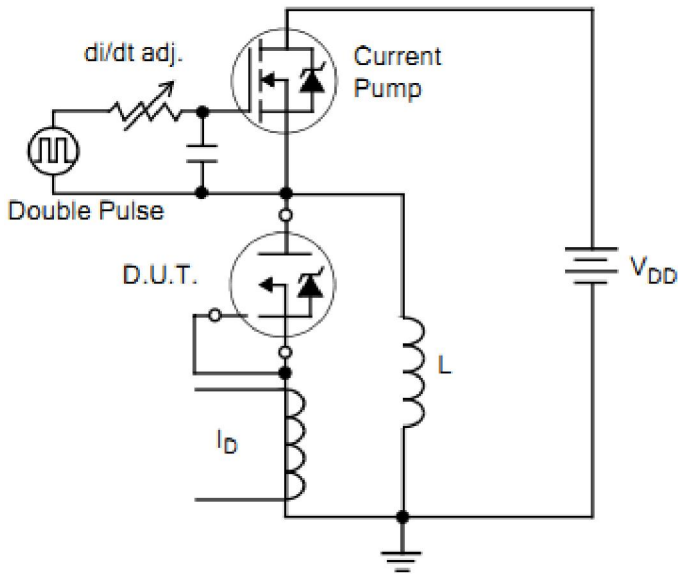

Figure 19. Diode Reverse Recovery Waveform

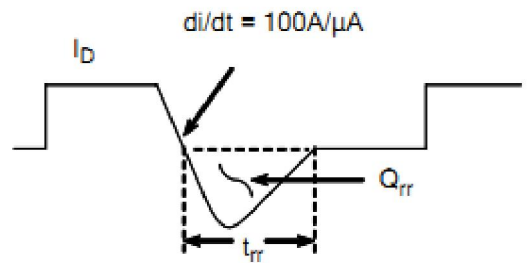

Figure20.Unclamped Inductive Switching Test Circuit

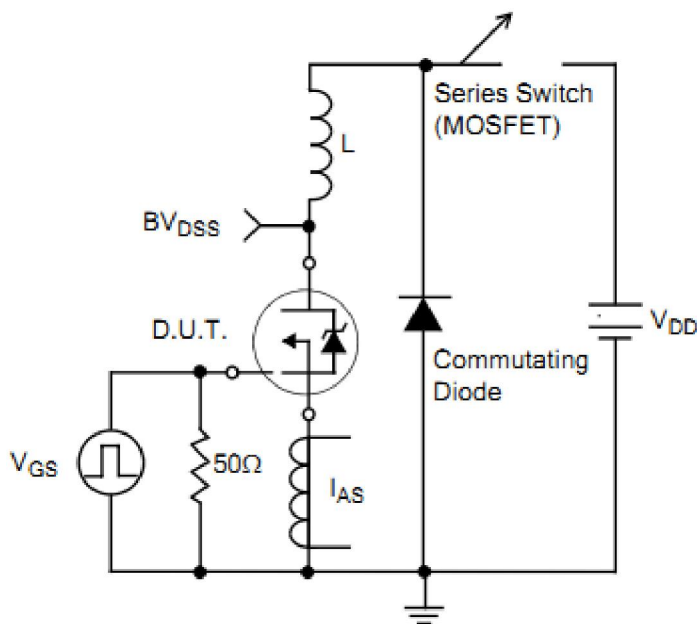
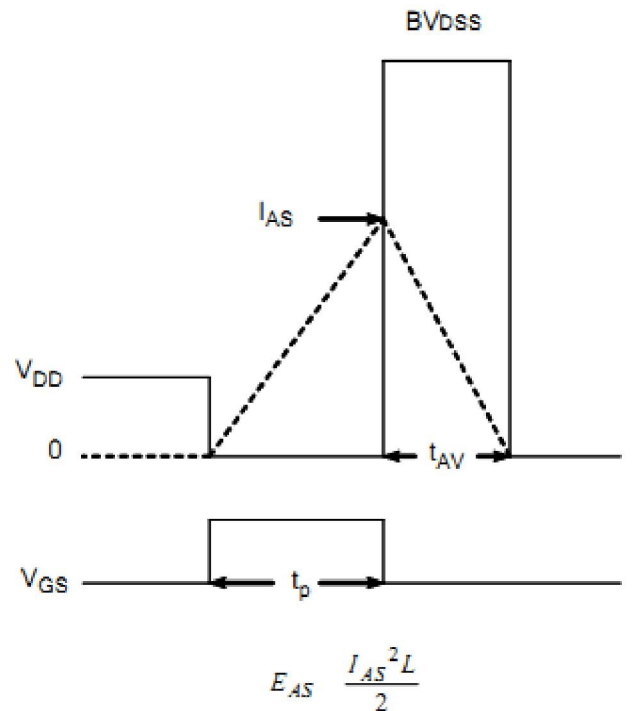

Figure21.Unclamped Inductive Switching Waveform



Disclaimers:

InPower Semiconductor Co., Ltd (IPS) reserves the right to make changes without notice in order to improve reliability, function or design and to discontinue any product or service without notice. Customers should obtain the latest relevant information before orders and should verify that such information is current and complete. All products are sold subject to IPS's terms and conditions supplied at the time of order acknowledgement.

InPower Semiconductor Co., Ltd warrants performance of its hardware products to the specifications at the time of sale, Testing reliability and quality control are used to the extent IPS deems necessary to support this warrantee. Except where agreed upon by contractual agreement, testing of all parameters of each product is not necessarily performed.

InPower Semiconductor Co., Ltd does not assume any liability arising from the use of any product or circuit designs described herein. Customers are responsible for their products and applications using IPS's components. To minimize risk, customers must provide adequate design and operating safeguards.

InPower Semiconductor Co., Ltd does not warrant or convey any license either expressed or implied under its patent rights, nor the rights of others. Reproduction of information in IPS's data sheets or data books is permissible only if reproduction is without modification or alteration. Reproduction of this information with any alteration is an unfair and deceptive business practice. InPower Semiconductor Co., Ltd is not responsible or liable for such altered documentation.

Resale of IPS's products with statements different from or beyond the parameters stated by InPower Semiconductor Co., Ltd for that product or service voids all express or implied warranties for the associated IPS's product or service and is unfair and deceptive business practice. InPower Semiconductor Co., Ltd is not responsible or liable for any such statements.

Life Support Policy:

InPower Semiconductor Co., Ltd's products are not authorized for use as critical components in life support devices or systems without the expressed written approval of InPower Semiconductor Co., Ltd.

As used herein:

1. Life support devices or systems are devices or systems which:
 - a. are intended for surgical implant into the human body,
 - b. support or sustain life,
 - c. whose failure to perform when properly used in accordance with instructions for use provided in the labeling, can be reasonably expected to result in significant injury to the user.
2. A critical component is any component of a life support device or system whose failure to perform can be reasonably expected to cause the failure of the life support device or system, or to affect its safety or effectiveness.