

IW4006B

**CMOS 18-Stage
Static Shift Register**

The RCA-4006B types are composed of 4 separate shift register sections: two sections of four stages and two sections of five stages with an output tar at the fourth stage. Each section has an independent single-rail data path.

- Standardized, symmetrical output characteristics
- Operating Voltage Range: 3.0 to 18 V
- 100% tested for guescent current at 20 V
- Maximum input current of 1 μ A at 18 V over full package-temperature range; 100 nA at 18 V and 25°C
- Noise margin (full package temperature range):
 - 1.0 V at $V_{DD}=5.0$ V
 - 2.0 V at $V_{DD}=10.0$ V
 - 2.5 V at $V_{DD}=15.0$ V

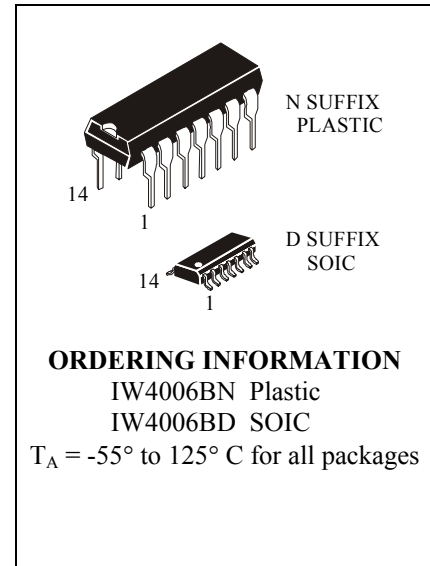

PIN ASSIGNMENT

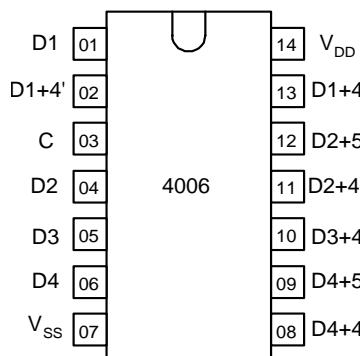

TERMINAL ASSIGNMENT

Pin.No	Symbol	Description
01	D1	Input Data
02	D1+4'	Output Data
03	C	Clock Data
04	D2	Input Data
05	D3	Input Data
06	D4	Input Data
07	V_{SS}	Ground
08	D4+4	Output Data
09	D4+5	Output Data
10	D3+4	Output Data
11	D2+4	Output Data
12	D2+5	Output Data
13	D1+4	Output Data
14	V_{DD}	Positive Power Supply

FUNCTION TABLE

Inputs			Outputs	
C	D1	D2-D4	D1+4...D4+4	D1+4'
\lceil	L	L	L	Storage
\lceil	H	H	H	Storage
\lceil	X	X	Storage	D1
\lceil	L	X	Storage	L
\lceil	H	X	Storage	H
\lceil	X	X	D1...D4	Storage

X = don't care

MAXIMUM RATINGS*

Symbol	Parameter	Value	Unit
V _{DD}	DC Supply Voltage (Referenced to GND)	-0.5 to +20	V
V _{IN}	DC Input Voltage (Referenced to GND)	-0.5 to V _{DD} +0.5	V
I _{IN}	DC Input Current, per Pin	±10	mA
P _D	Power Dissipation in Still Air, Plastic DIP, SOIC Package	500**	mW
P _{tot}	Power Dissipation per Output Transistor	100	mW
T _{stg}	Storage Temperature	-65 to +150	°C
T _L	Lead Temperature, 1 mm from Case for 10 Seconds (Plastic DIP or SOIC Package)	260	°C

*Maximum Ratings are those values beyond which damage to the device may occur. Functional operation should be restricted to the Recommended Operating Conditions.

**Derating: - Plastic DIP from -55 to +100°C
 - SOIC Package from -55 to +65°C
 - Plastic DIP: - 12 mW/°C from +100 to +125°C
 - SOIC Package: - 7 mW/°C from +65 to +125°C

RECOMMENDED OPERATING CONDITIONS

Symbol	Parameter	Min	Max	Unit
V _{CC}	DC Supply Voltage (Referenced to GND)	3.0	18	V
V _{IN}	DC Input Voltage (Referenced to GND)	0	V _{CC}	V
T _A	Operating Temperature, All Package Types	-55	+125	°C

This device contains protection circuitry to guard against damage due to high static voltages or electric fields. However, precautions must be taken to avoid applications of any voltage higher than maximum rated voltages to this high-impedance circuit. For proper operation V_{IN} should be constrained to the range GND ≤ V_{IN} ≤ V_{CC}.

Unused inputs must always be tied to an appropriate logic voltage level (e.g., either V_{SS} or V_{DD}). Unused outputs must be left open.

DC ELECTRICAL CHARACTERISTICS

Symbol	Parameter	Test Conditions	V _{DD} , V	Guaranteed Limit						Unit
				55°C		125°C		25°C		
				min	max	min	max	min	max	
V _{IH}	Minimum High-Level Input Voltage	V _O = 0.5 V or V _{DD} -0.5 V	5.0	3.5	-	3.5	-	3.5	-	V
		V _O = 1.0 V or V _{DD} -1.0 V	10	7.0	-	7.0	-	7.0	-	
		V _O = 1.5 V or V _{DD} -1.5 V	15	11	-	11	-	11	-	
V _{IL}	Maximum Low - Level Input Voltage	V _O = 0.5 V or V _{DD} -0.5 V	5.0	-	1.5	-	1.5	-	1.5	V
		V _O = 1.0 V or V _{DD} -1.0 V	10	-	3.0	-	3.0	-	3.0	
		V _O = 1.5 V or V _{DD} -1.5 V	15	-	4.0	-	4.0	-	4.0	
V _{OH}	Minimum High-Level Output Voltage	V _I = V _{SS} или V _{DD}	5.0	4.95	-	4.95	-	4.95	-	V
			10	9.95	-	9.95	-	9.95	-	
			15	14.95	-	14.95	-	14.95	-	
V _{OL}	Maximum Low-Level Output Voltage	V _I = V _{SS} или V _{DD}	5.0	-	0.05	-	0.05	-	0.05	V
			10	-	0.05	-	0.05	-	0.05	
			15	-	0.05	-	0.05	-	0.05	
I _{IL}	Maximum Input Current	V _I = V _{SS}	18	-	-0.1	-	-1.0	-	-0.1	μA
I _{IH}	Maximum Input Leakage Current	V _I = V _{DD}	18	-	+0.1	-	+1.0	-	+0.1	μA
I _{DD}	Maximum Quiescent Supply Current (per Package)	V _I = V _{SS} or V _{DD}	5.0	-	5.0	-	150	-	5.0	μA
			10	-	10.0	-	300	-	10	
			15	-	20.0	-	600	-	20	
			20	-	100	-	3000	-	100	
I _{OL}	Minimum Output Low (Sink) Current	V _I = V _{SS} or V _{DD} V _{OL} = 0.4 V V _{OL} = 0.5 V V _{OL} = 1.5 V	5.0	0.64	-	0.36	-	0.51	-	mA
			10	1.6	-	0.9	-	1.3	-	
			15	4.2	-	2.4	-	3.4	-	
I _{OH}	Minimum Output High (Source) Current	V _I = V _{SS} or V _{DD} V _{OH} = 2.5 V V _{OH} = 4.6 V V _{OH} = 9.5 V V _{OH} = 13.5 V	5.0	-2.0	-	-1.15	-	-1.6	-	mA
			5.0	-0.64	-	-0.36	-	-0.51	-	
			10	-1.6	-	-0.9	-	-1.3	-	
			15	-4.2	-	-2.4	-	-3.4	-	
C _{IN}	Maximum Input Capacitance		-	-	-	-	-	-	7.5	pF

TIMING REQUIREMENTS ($C_L=50$ пФ, $R_L = 200$ кОм, $t_{LH} = t_{HL} \leq 20$ нс)

Symbol	Parameter	U_{DD} , V	Guaranteed Limit						Unit
			55°C		125°C		25°C		
			min	max	min	max	min	max	
t_{PHL} , t_{PLH}	Propagation Delay Time	5.0 10 15	- 400 160	400 200 160	- 800 320	800 400 320	- 400 160	400 200 160	ns
t_{THL} , t_{TLH}	Transition Time	5.0 10 15	- 200 80	200 100 80	- 400 160	400 200 160	- 200 80	200 100 80	ns
t_{SU}	Minimum Data Setup Time	5.0 10 15	100 50 40	- 100 80	200 100 80	- 100 40	100 50 40	- - -	ns
t_H	Minimum Hold Time, Clock to Data	5.0 10 15	150 80 60	- 300 160 120	300 160 120	- 150 80 60	150 80 60	- - -	ns
t_w	Minimum Clock Pulse Width	5.0 10 15	200 90 60	- 400 180 120	400 180 120	- 200 90 60	200 90 60	- - -	nc
f_C	Maximum Clock Input Frequency	5.0 10 15		2.5 5.0 7.0		1.25 2.5 3.5		2.5 5.0 7.0	MHz
$t_{r(CL)}$, $t_{f(CL)}$	Maximum Clock Input Rise or Fall Time	5.0 10 15		15 15 15		15 15 15		15 15 15	μs

LOGIS DIAGRAM WITH DETAIL OF LATCH

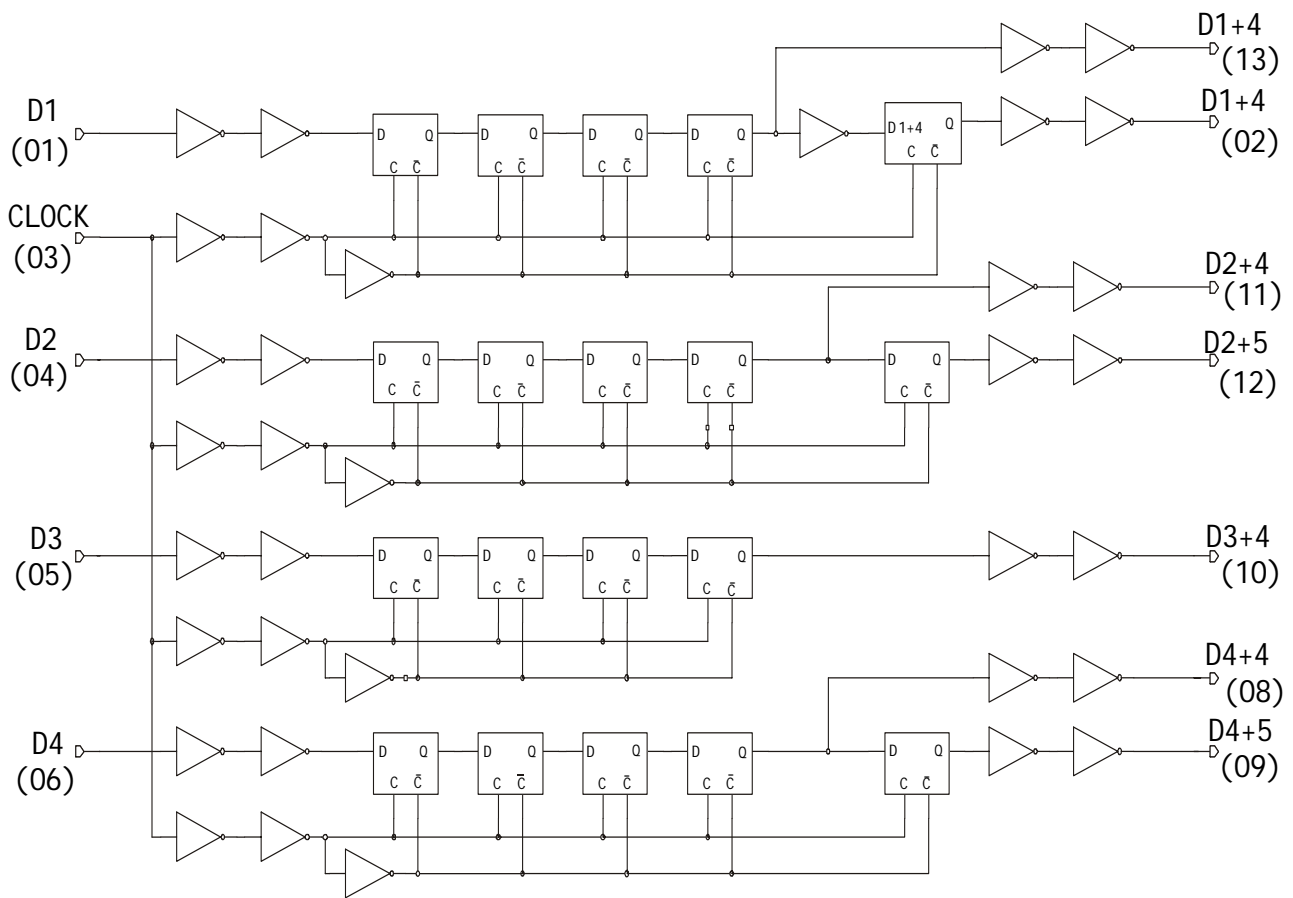

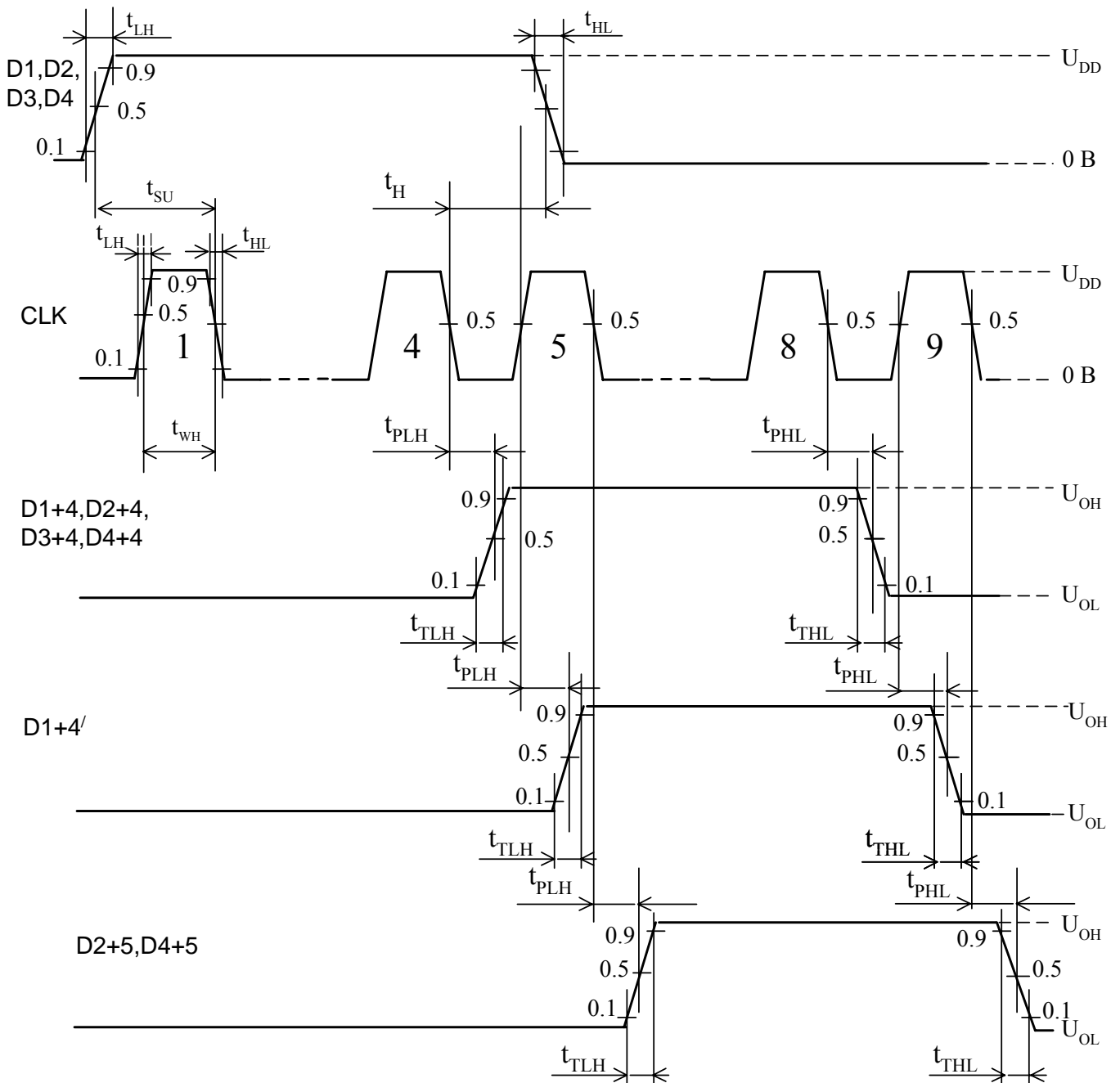

SWITCHING WAVEFORMS

**N SUFFIX PLASTIC DIP
(MS - 001AA)**

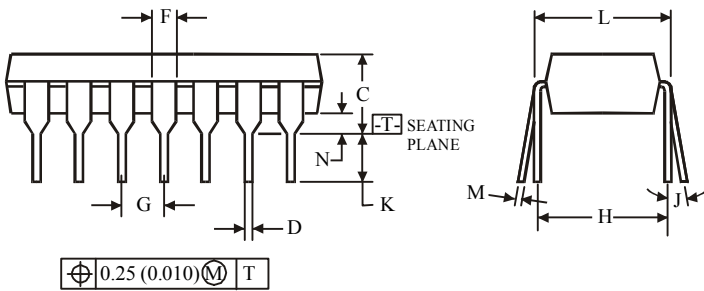
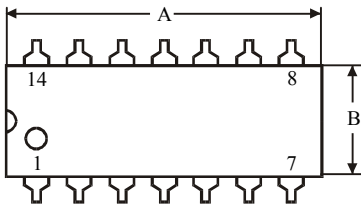
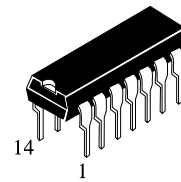

Symbol	Dimensions, mm	
	MIN	MAX
A	18.67	19.69
B	6.10	7.11
C		5.33
D	0.36	0.56
F	1.14	1.78
G	2.54	
H	7.62	
J	0°	10°
K	2.92	3.81
L	7.62	8.26
M	0.20	0.36
N	0.38	

NOTES:

- Dimensions "A", "B" do not include mold flash or protrusions. Maximum mold flash or protrusions 0.25 mm (0.010) per side.

**D SUFFIX SOIC
(MS - 012AB)**

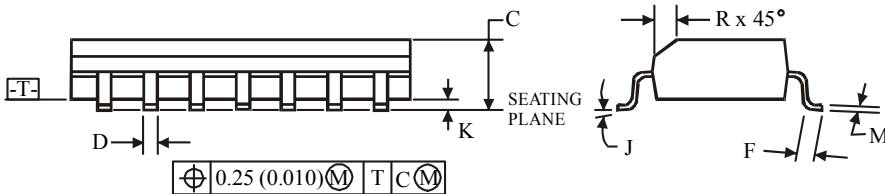
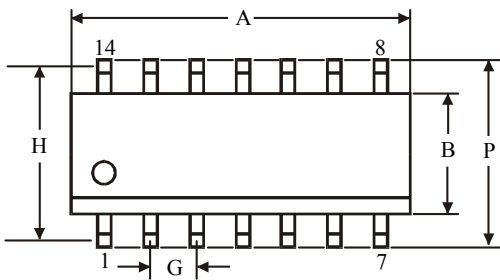
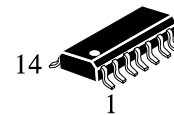

Symbol.	Dimensions, mm	
	MIN	MAX
A	8.55	8.75
B	3.80	4.00
C	1.35	1.75
D	0.33	0.51
F	0.40	1.27
G	1.27	
H	5.72	
J	0°	8°
K	0.10	0.25
M	0.19	0.25
P	5.80	6.20
R	0.25	0.50

NOTES:

- Dimensions A and B do not include mold flash or protrusion.
- Maximum mold flash or protrusion 0.15 mm (0.006) per side for A; for B - 0.25 mm (0.010) per side.