

**IW4017B**

**Counter/Divider**

The IW4017B is 5-stage Johnson counter having 10 decoded outputs. Inputs include a CLOCK, a RESET, and a CLOCK INHIBIT signal. Schmitt trigger action in the CLOCK input circuit provides pulse shaping that allows unlimited clock input pulse rise and fall times.

The counter is advanced one count at the positive clock signal transition if the CLOCK INHIBIT signal is low. Counter advancement via the clock line is inhibited when the CLOCK INHIBIT signal is high. A high RESET signal clears the counter to its zero count. Use of the Johnson counter configuration permits high-speed operation, 2-input decode-gating and spike-free decoded outputs. Anti-lock gating is provided, thus assuring proper counting sequence. The decoded outputs are normally low and go high only at their respective decoded time slot. Each decoded output remains high for one full clock cycle. A CARRY-OUT signal completes one cycle every 10 clock input cycles.

- Operating Voltage Range: 3.0 to 18 V
- Maximum input current of 1  $\mu$ A at 18 V over full package-temperature range; 100 nA at 18 V and 25°C
- Noise margin (over full package temperature range):
  - 1.0 V min @ 5.0 V supply
  - 2.0 V min @ 10.0 V supply
  - 2.5 V min @ 15.0 V supply

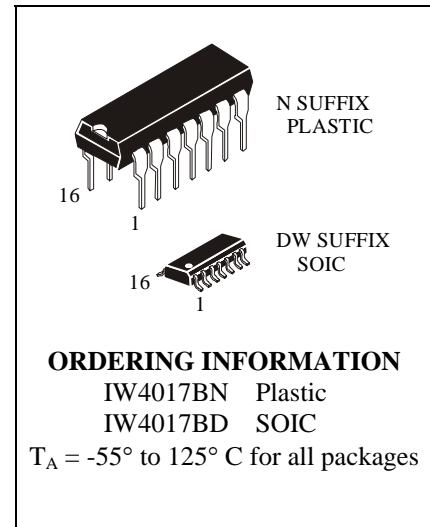

**PIN ASSIGNMENT**

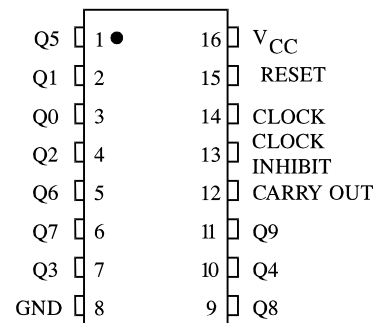

**LOGIC DIAGRAM**

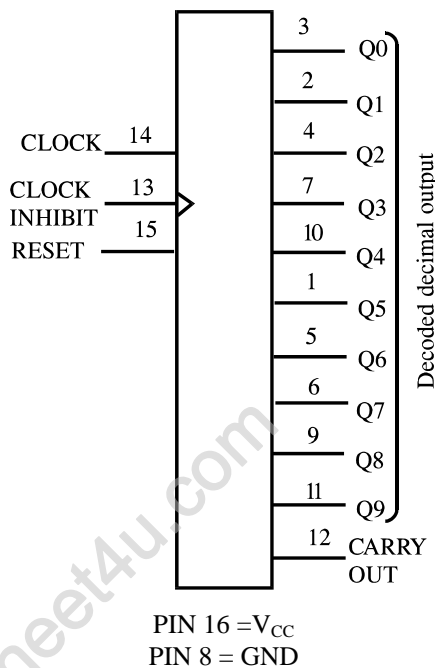

**FUNCTION TABLE**

Clock	Clock Enable	Reset	Output State
L	X	L	no change
X	H	L	no change
X	X	H	reset counter Q0=H, Q1-Q9=L, C0=H
	L	L	Advance to next state
	X	L	no change
X		L	no change
H		L	Advance to next state

Carry Out=H for Q0,Q1,Q2,Q3 or Q4=H  
 Carry Out = L otherwise, X=don't care

**MAXIMUM RATINGS\***

Symbol	Parameter	Value	Unit
V <sub>CC</sub>	DC Supply Voltage (Referenced to GND)	-0.5 to 20	V
V <sub>IN</sub>	DC Input Voltage (Referenced to GND)	-0.5 to V <sub>CC</sub> 0.5	V
V <sub>OUT</sub>	DC Output Voltage (Referenced to GND)	-0.5 to V <sub>CC</sub> 0.5	V
I <sub>IN</sub>	DC Input Current, per Pin	±10	mA
P <sub>D</sub>	Power Dissipation in Still Air, Plastic DIP**	750	mW
	SOIC Package**	500	
P <sub>D</sub>	Power Dissipation per Output Transistor	100	mW
T <sub>stg</sub>	Storage Temperature	-65 to 150	°C
T <sub>L</sub>	Lead Temperature, 1 mm from Case for 10 Seconds (Plastic DIP or SOIC Package)	260	°C

\*Maximum Ratings are those values beyond which damage to the device may occur. Functional operation should be restricted to the Recommended Operating Conditions.

\*\*Derating - Plastic DIP: - 10 mW/°C from 65° to 125°C  
SOIC Package: : - 7 mW/°C from 65° to 125°C

**RECOMMENDED OPERATING CONDITIONS**

Symbol	Parameter	Min	Max	Unit
V <sub>CC</sub>	DC Supply Voltage (Referenced to GND)	3.0	18	V
V <sub>IN</sub> , V <sub>OUT</sub>	DC Input Voltage, Output Voltage (Referenced to GND)	0	V <sub>CC</sub>	V
T <sub>A</sub>	Operating Temperature, All Package Types	-55	125	°C

This device contains protection circuitry to guard against damage due to high static voltages or electric fields. However, precautions must be taken to avoid applications of any voltage higher than maximum rated voltages to this high-impedance circuit. For proper operation, V<sub>IN</sub> and V<sub>OUT</sub> should be constrained to the range GND ≤ (V<sub>IN</sub> or V<sub>OUT</sub>) ≤ V<sub>CC</sub>.

Unused inputs must always be tied to an appropriate logic voltage level (e.g., either GND or V<sub>CC</sub>). Unused outputs must be left open.

**DC ELECTRICAL CHARACTERISTICS** (Voltages Referenced to GND)

Symbol	Parameter	Test Conditions	V <sub>CC</sub> V	Guaranteed Limit			Unit
				≥-55°C	25°C	≤125°C	
V <sub>IH</sub>	Minimum High-Level Input Voltage	V <sub>OUT</sub> =0.5 V or V <sub>CC</sub> - 0.5 V	5.0	3.5	3.5	3.5	V
		V <sub>OUT</sub> =1.0 V or V <sub>CC</sub> - 1.0 V	10	7	7	7	
		V <sub>OUT</sub> =1.5 V or V <sub>CC</sub> - 1.5 V	15	11	11	11	
V <sub>IL</sub>	Maximum Low - Level Input Voltage	V <sub>OUT</sub> =0.5 V or V <sub>CC</sub> - 0.5 V	5.0	1.5	1.5	1.5	V
		V <sub>OUT</sub> =1.0 V or V <sub>CC</sub> - 1.0 V	10	3	3	3	
		V <sub>OUT</sub> =1.5 V or V <sub>CC</sub> - 1.5 V	15	4	4	4	
V <sub>OH</sub>	Minimum High-Level Output Voltage	V <sub>IN</sub> =GND or V <sub>CC</sub>	5.0	4.95	4.95	4.95	V
			10	9.95	9.95	9.95	
			15	14.95	14.95	14.95	
		V <sub>IL</sub> =1.5V, V <sub>IH</sub> =3.5V, I <sub>O</sub> =-1μA	5.0	4.5	4.5	4.5	
		V <sub>IL</sub> =3.0V, V <sub>IH</sub> =7.0V, I <sub>O</sub> =-1μA	10	9.0	9.0	9.0	
		V <sub>IL</sub> =4.0V, V <sub>IH</sub> =11V, I <sub>O</sub> =-1μA	15	13.5	13.5	13.5	
V <sub>OL</sub>	Maximum Low-Level Output Voltage	V <sub>IN</sub> =GND or V <sub>CC</sub>	5.0	0.05	0.05	0.05	V
			10	0.05	0.05	0.05	
			15	0.05	0.05	0.05	
		V <sub>IL</sub> =1.5V, V <sub>IH</sub> =3.5V, I <sub>O</sub> =1μA	5.0	0.5	0.5	0.5	
		V <sub>IL</sub> =3.0V, V <sub>IH</sub> =7.0V, I <sub>O</sub> =1μA	10	1.0	1.0	1.0	
		V <sub>IL</sub> =4.0V, V <sub>IH</sub> =11V, I <sub>O</sub> =1μA	15	1.5	1.5	1.5	
I <sub>IN</sub>	Maximum Input Leakage Current	V <sub>IN</sub> = GND or V <sub>CC</sub>	18	±0.1	±0.1	±1.0	μA
I <sub>CC</sub>	Maximum Quiescent Supply Current (per Package)	V <sub>IN</sub> = GND or V <sub>CC</sub>	5.0	1.0	1.0	30	μA
			10	2.0	2.0	60	
			15	4.0	4.0	120	
			20	20	20	600	
I <sub>OL</sub>	Minimum Output Low (Sink) Current	V <sub>IN</sub> = GND or V <sub>CC</sub>					mA
		V <sub>OL</sub> =0.4 V	5.0	0.64	0.51	0.36	
		V <sub>OL</sub> =0.5 V	10	1.6	1.3	0.9	
		V <sub>OL</sub> =1.5 V	15	4.2	3.4	2.4	
I <sub>OH</sub>	Minimum Output High (Source) Current	V <sub>IN</sub> = GND or V <sub>CC</sub>					mA
		V <sub>OH</sub> =4.6 V	5.0	-0.64	-0.51	-0.36	
		V <sub>OH</sub> =2.5 V	5.0	-2.0	-1.6	-1.15	
		V <sub>OH</sub> =9.5 V	10	-1.8	-1.3	-0.9	
	V <sub>OH</sub> =13.5 V	15	-4.2	-3.4	-2.4		

**AC ELECTRICAL CHARACTERISTICS** ( $C_L=50\text{pF}$ ,  $R_L=200\text{k}\Omega$ , Input  $t_r=t_f=20\text{ ns}$ )

Symbol	Parameter	V <sub>CC</sub> V	Guaranteed Limit			Unit
			≥-55°C	25°C	≤125°C	
f <sub>max</sub>	Maximum Clock Frequency	5.0	2.5	2.5	2.0	MHz
		10	5	5	4.0	
		15	5.5	5.5	5.0	
t <sub>PLH</sub> , t <sub>PHL</sub>	Maximum Propagation Delay, Clock to Decode Output (Figure 1)	5.0	650	650	800	ns
		10	270	270	350	
		15	170	170	250	
t <sub>PLH</sub> , t <sub>PHL</sub>	Maximum Propagation Delay, Clock to Carry Output (Figure 1)	5.0	600	600	750	ns
		10	250	250	300	
		15	160	160	200	
t <sub>TLH</sub> , t <sub>THL</sub>	Maximum Output Transition Time, Carry Output or Decode Output (Figure 1)	5.0	200	200	300	ns
		10	100	100	150	
		15	80	80	120	
t <sub>PLH</sub> , t <sub>PHL</sub>	Maximum Propagation Delay, Reset to Carry Output or Decode Output (Figure 1)	5.0	530	530	700	ns
		10	230	230	300	
		15	170	170	250	
C <sub>IN</sub>	Maximum Input Capacitance	-		5		pF

**TIMING REQUIREMENTS** ( $V_{CC}=5.0\text{V}\pm 10\%$ ,  $C_L=50\text{pF}$ , Input  $t_r=t_f=20\text{ ns}$ ,  $R_L=200\text{k}\Omega$ )

Symbol	Parameter	V <sub>CC</sub> V	Guaranteed Limit			Unit
			≥-55°C	25°C	≤125°C	
t <sub>w</sub>	Minimum Pulse Width, Clock (Figure 1)	5.0	200	200	300	ns
		10	90	90	150	
		15	60	60	100	
t <sub>r</sub> , t <sub>f</sub>	Maximum Input Rise and Fall Times, Clock (Figure 1)	5.0	UNLIMITED			μs
		10				
		15				
t <sub>w</sub>	Minimum Pulse Width, Reset (Figure 1)	5.0	260	260	400	ns
		10	110	110	180	
		15	60	60	100	
t <sub>rem</sub>	Minimum Removal Time, Reset (Figure 1)	5.0	400	400	550	ns
		10	280	280	400	
		15	150	150	200	
t <sub>SU</sub>	Minimum Setup Time, Clock Inhibit to Clock (Figure 1)	5.0	230	230	300	ns
		10	100	100	150	
		15	70	70	100	

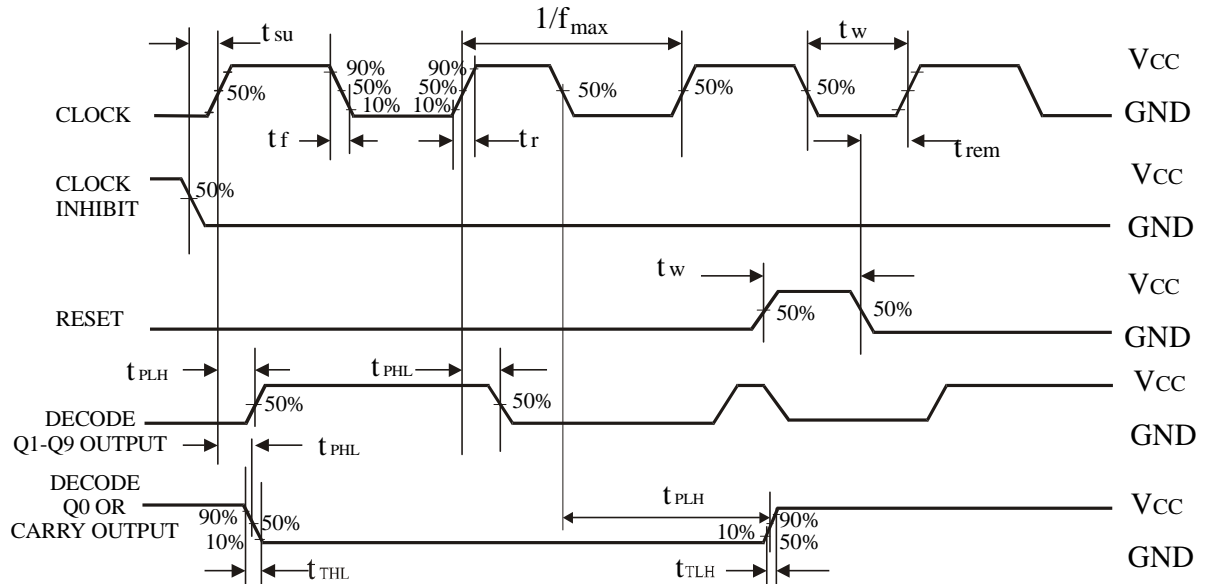
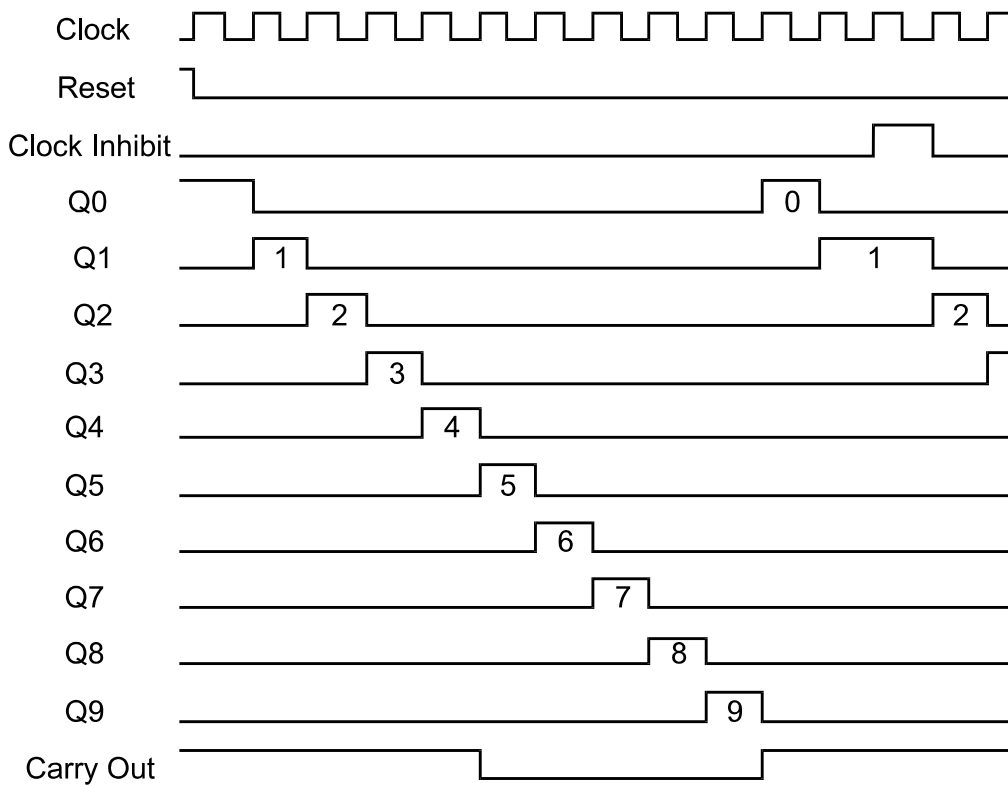
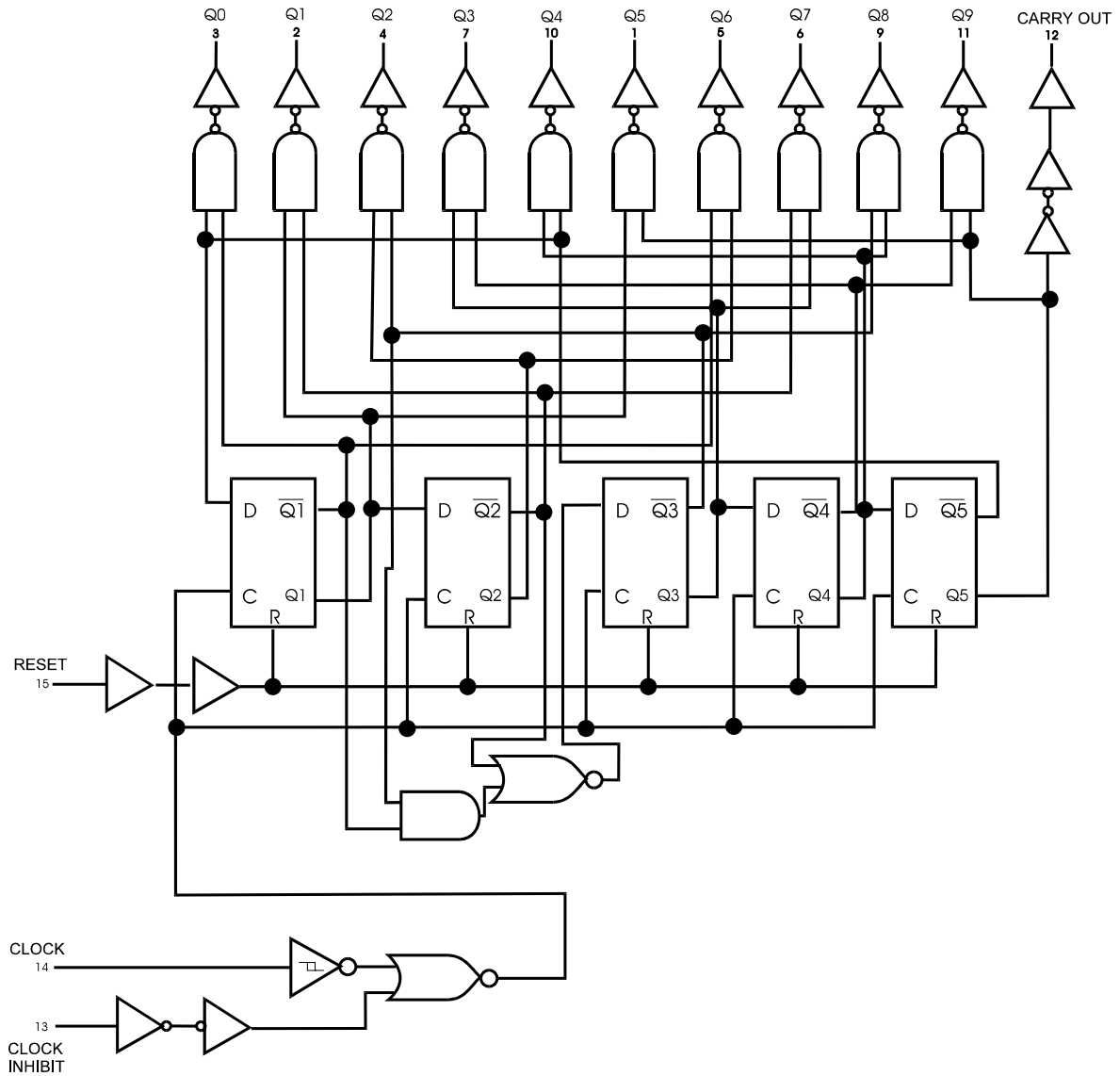

Figure 1. Switching Waveforms

Timing diagram



EXPANDED LOGIC DIAGRAM



**N SUFFIX PLASTIC  
(MS - 001BB)**

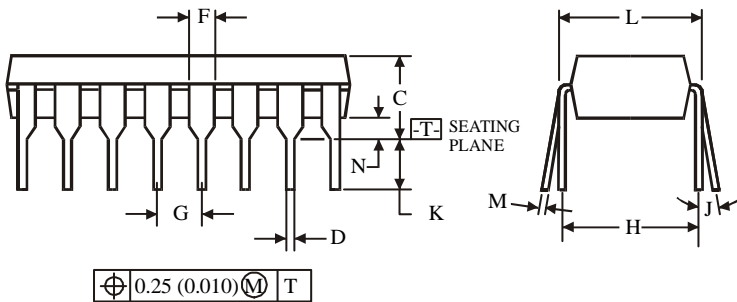
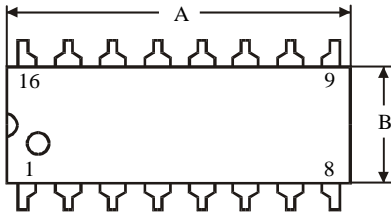
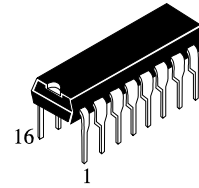

Symbol	Dimensions, mm	
	MIN	MAX
A	18.67	19.69
B	6.10	7.11
C		5.33
D	0.36	0.56
F	1.14	1.78
G	2.54	
H	7.62	
J	0°	10°
K	2.92	3.81
L	7.62	8.26
M	0.20	0.36
N	0.38	

**NOTES:**

- Dimensions "A", "B" do not include mold flash or protrusions. Maximum mold flash or protrusions 0.25 mm (0.010) per side.

**D SUFFIX SOIC  
(MS - 012AC)**

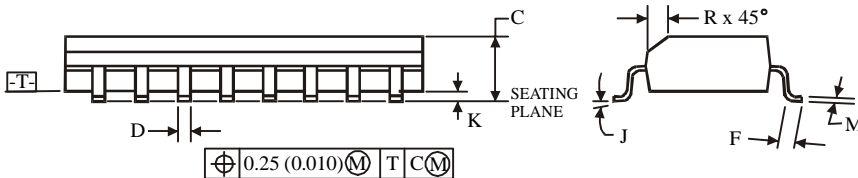
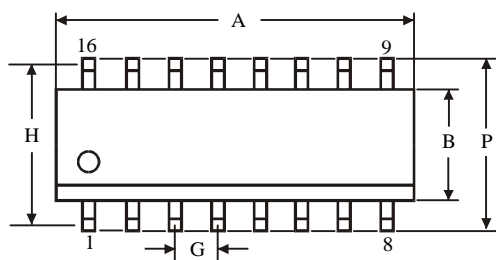
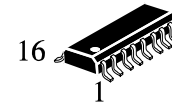

Symbol.	Dimensions, mm	
	MIN	MAX
A	9.80	10.0
B	3.80	4.00
C	1.35	1.75
D	0.33	0.51
F	0.40	1.27
G	1.27	
H	5.72	
J	0°	8°
K	0.10	0.25
M	0.19	0.25
P	5.80	6.20
R	0.25	0.50

**NOTES:**

- Dimensions A and B do not include mold flash or protrusion.
- Maximum mold flash or protrusion 0.15 mm (0.006) per side for A, for B - 0.25 mm (0.010) per side.