

IW4051B

**Analog Multiplexer Demultiplexer
High-Performance Silicon-Gate CMOS**

The IW4051B analog multiplexer/demultiplexer is digitally controlled analog switches having low ON impedance and very low OFF leakage current. Control of analog signals up to 20V peak-to-peak can be achieved by digital signal amplitudes of 4.5 to 20V (if $V_{CC} - GND = 3V$, a $V_{CC} - V_{EE}$ of up to 13 V can be controlled; for $V_{CC} - V_{EE}$ level differences above 13V a $V_{CC} - GND$ of at least 4.5V is required).

These multiplexer circuits dissipate extremely low quiescent power over the full $V_{CC} - GND$ and $V_{CC} - V_{EE}$ supply-voltage ranges, independent of the logic state of the control signals. When a logic "1" is present at the ENABLE input terminal all channels are off.

The IW4051B is a single 8-channel multiplexer having three binary control inputs, A, B and C, and an ENABLE input. The three binary signals select 1 of 8 channels to be turned on, and connect one of the 8 inputs to the output.

- Operating Voltage Range: 3.0 to 18 V
- Maximum input current of 1 μA at 18 V over full package-temperature range; 100 nA at 18 V and 25°C
- Noise margin (over full package temperature range):
 - 1.0 V min @ 5.0 V supply
 - 2.0 V min @ 10.0 V supply
 - 2.5 V min @ 15.0 V supply

N SUFFIX PLASTIC
D SUFFIX SOIC

ORDERING INFORMATION
IW4051BN Plastic DIP
IW4051BD SOIC
 $T_A = -55^\circ$ to 125° C for all packages

PIN ASSIGNMENT

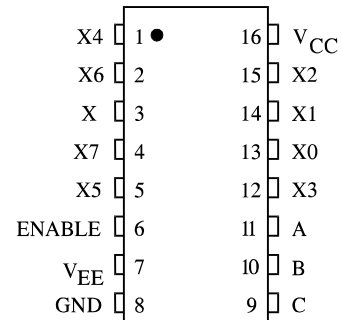

LOGIC DIAGRAM

Single-Pole, 8-Position Plus Common Off

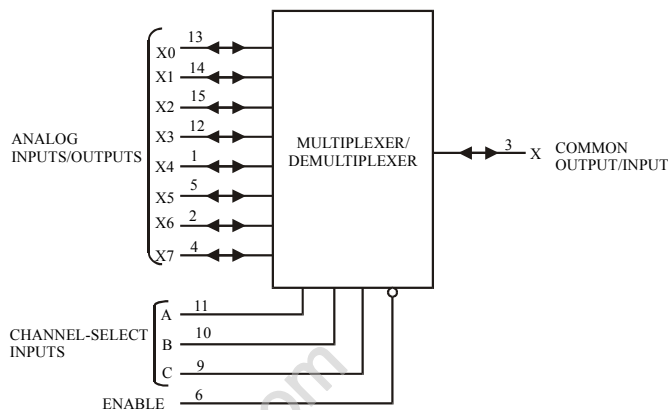

PIN 16 = V_{CC}
 PIN 7 = V_{EE}
 PIN 8 = GND

FUNCTION TABLE

Control Inputs				ON Channels
Enable	Select			
	C	B	A	
L	L	L	L	X0
L	L	L	H	X1
L	L	H	L	X2
L	L	H	H	X3
L	H	L	L	X4
L	H	L	H	X5
L	H	H	L	X6
L	H	H	H	X7
H	X	X	X	None

H = high level
 L = low level
 X = don't care

MAXIMUM RATINGS*

Symbol	Parameter	Value	Unit
V _{CC}	DC Supply Voltage (Referenced to GND)	-0.5 to +20	V
V _{IN}	DC Input Voltage (Referenced to GND)	-0.5 to V _{CC} +0.5	V
I _{IN}	DC Input Current, per Pin	±10	mA
P _D	Power Dissipation in Still Air	500* ¹	mW
P _{tot}	Power Dissipation per Output Transistor	100	mW
T _{stg}	Storage Temperature	-65 to +150	°C
T _L	Lead Temperature, 1 mm from Case for 10 Seconds (Plastic DIP or SO Package)	260	°C

*Maximum Ratings are those values beyond which damage to the device may occur. Functional operation should be restricted to the Recommended Operating Conditions.

*¹ - for Plastic DIP from -55° to +100°C, for SO Package from -55° to +65°C.

+Derating - Plastic DIP: - 12 mW/°C from 100° to 125°C

SO Package: - 7 mW/°C from 65° to 125°C

RECOMMENDED OPERATING CONDITIONS

Symbol	Parameter	Min	Max	Unit
V _{CC}	DC Supply Voltage (Referenced to GND)	3.0	18	V
V _{IN}	DC Input Voltage (Referenced to GND)	0	V _{CC}	V
T _A	Operating Temperature, All Package Types	-55	+125	°C

This device contains protection circuitry to guard against damage due to high static voltages or electric fields. However, precautions must be taken to avoid applications of any voltage higher than maximum rated voltages to this high-impedance circuit. For proper operation, V_{IN} and V_{OUT} should be constrained to the range GND ≤ (V_{IN} or V_{OUT}) ≤ V_{CC}.

Unused digital pins must be tied to an appropriate logic voltage level (e.g., either GND or V_{CC}). Unused Analog I/O pins may be left open or terminated.

DC ELECTRICAL CHARACTERISTICS Digital Section

Symbol	Parameter	Test Conditions	V _{CC} V	Guaranteed Limit			Unit
				≥ -55 °C	≤ 25 °C	≤ 125 °C	
V _{IH}	Minimum High-Level Input Voltage, Channel-Select or Enable Inputs	V _{IS} =V _{CC} thru 1kΩ V _{EE} =GND=0 I _{IS} <2μA on all OFF Channels R _L =1kΩ to GND	5	3.5	3.5	3.5	V
			10	7	7	7	
			15	11	11	11	
V _{IL}	Maximum Low -Level Input Voltage, Channel-Select or Enable Inputs	V _{IS} =V _{CC} thru 1kΩ V _{EE} =GND=0 I _{IS} <2μA on all OFF Channels R _L =1kΩ to GND	5	1.5	1.5	1.5	V
			10	3	3	3	
			15	4	4	4	
I _{IN}	Maximum Input Leakage Current, Channel-Select or Enable Inputs	V _{IN} =V _{CC} or GND V _{EE} =GND=0	18	±0.1	±0.1	±1.0	μA
I _{CC}	Maximum Quiescent Supply Current (per Package)	Channel Select = V _{CC} or GND V _{EE} =GND=0	5	5	5	150	μA
			10	10	10	300	
			15	20	20	600	
			20	100	100	3000	

DC ELECTRICAL CHARACTERISTICS Analog Section

Symbol	Parameter	Test Conditions	V _{CC} V	Guaranteed Limit			Unit
				≥ -55 °C	≤ 25 °C	≤ 125 °C	
R _{ON}	Maximum “ON” Resistance	V _{EE} =GND=0 V _{IS} = GND to V _{CC}	5	800	1050	1150	Ω
			10	310	400	550	
			15	200	240	320	
ΔR _{ON}	Maximum Difference in “ON” Resistance Between Any Two Channels in the Same Package	V _{EE} =GND=0	5	-	10*	-	Ω
			10	-	15*	-	
			15	-	5*	-	
I _{OFF}	Maximum Off- Channel Leakage Current, Any One Channel	V _{EE} =GND=0	18	±100	±100	±1000	nA
	Maximum Off- Channel Leakage Current, Common Channel	V _{EE} =GND=0	18	±100	±100	±1000	

* - Typical Value

AC ELECTRICAL CHARACTERISTICS ($C_L=50\text{pF}$, Input $t_r=t_f=20.0\text{ ns}$)

Symbol	Parameter	V _{CC} V	Guaranteed Limit			Unit	
			≥ -55 °C	≤ 25 °C	≤ 125 °C		
t _{PHL} (t _{PLH})	Maximum Propagation Delay , Analog Input to Analog Output (Figure 1) R _L =200kΩ, V _{EE} =GND=0	5	60	60	70	ns	
		10	30	30	40		
		15	20	20	30		
t _{PHL1} (t _{PLH1})	Maximum Propagation Delay , Channel-Select Input to Analog Output (Figure 1) R _L =200 kΩ, V _{EE} =GND=0	5	350	350	400	ns	
		10	200	200	250		
		15	160	160	200		
t _{PZL1} (t _{PZH1})	Maximum Propagation Delay , Channel-Select Input to Analog Output (Figure 2) R _L =10 kΩ V _{EE} =GND=0	5	720	720	720	ns	
		10	320	320	320		
		15	240	240	240		
		V _{EE} =-5B, GND=0	5	450	450		450
t _{PZL2} (t _{PZH2})	Maximum Propagation Delay , Enable to Analog Output (Figure 2) R _L =10 kΩ V _{EE} =GND=0	5	720	720	720	ns	
		10	320	320	320		
		15	240	240	240		
		V _{EE} =-10B, GND=0	5	400	400		400
t _{PLZ1} (t _{PHZ1})	Maximum Propagation Delay , Channel-Select Input to Analog Output (Figure 2) R _L =10 kΩ V _{EE} =GND=0	5	720	720	720	ns	
		10	320	320	320		
		15	240	240	240		
		V _{EE} =-5B, GND=0	5	450	450		450
t _{PLZ2} (t _{PHZ2})	Maximum Propagation Delay , Enable to Analog Output (Figure 2) R _L =1,0 kΩ V _{EE} =GND=0	5	450	450	450	ns	
		10	210	210	210		
		15	160	160	160		
		V _{EE} =-10B, GND=0	5	300	300		600
C _{IN}	Maximum Input Capacitance, Channel-Select or Enable Inputs	-	-	7.5	-	pF	
C _{I/O}	Maximum Capacitance V _{EE} =GND=-5V					pF	
		C _{IS}	5	-	5*		-
		C _{OS}	5	-	30*		-
		Feedthrough C _{IOS}	5	-	0.2*		-

ADDITIONAL APPLICATION CHARACTERISTICS

Symbol	Parameter	Test Conditions	V _{CC} V	V _{IS} ** V	Limits	Unit
					Typical Value	
					25 °C	
B _w	Maximum On-Channel Bandwidth or Minimum Frequency Response (-3db)	V _{EE} =GND=0 R _L =1kΩ 20 log(V _{OS} /V _{IS})=-3db V _{OS} at Common OUT/IN	10	2,5	20	MHz
		V _{OS} at Any Channel	10	2,5	60	
f ₁	(-40db) Feedthrough Frequency (All Channels OFF)	V _{EE} =GND=0 R _L =1kΩ 20 log(V _{OS} /V _{IS})=-40db V _{OS} at Common OUT/IN	10	2,5	12	MHz
		V _{OS} at Any Channel	10	2,5	8	
f ₂	(-40db) Signal Crosstalk Frequency	V _{EE} =GND=0 R _L =1kΩ 20 log(V _{OS} /V _{IS})=-40db Between Any 2 Channels	10	2,5	3	MHz
THD	Total Harmonic Distortion	V _{EE} =GND=0 f _{IS} =1kHz sine wave	5	1	0.3	%
			10	1,5	0.2	
			15	2,5	0.12	
V _{AO/I}	Address-or Enable to Signal Crosstalk	V _{EE} =GND=0, R _L =10kΩ*** t _r ,t _f =20ns Square Wave	10	-	65	mV (Peak)

** Peak-to-peak voltage symmetrical about (V_{CC}-V_{EE})/2.

*** Both ends of channel.

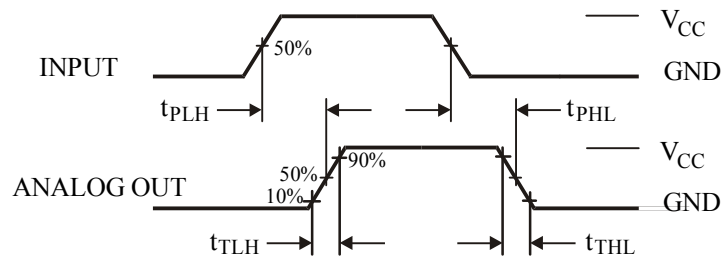

Figure 1. Switching Waveforms

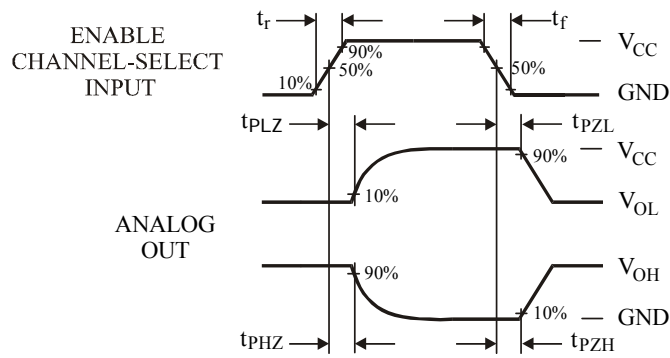
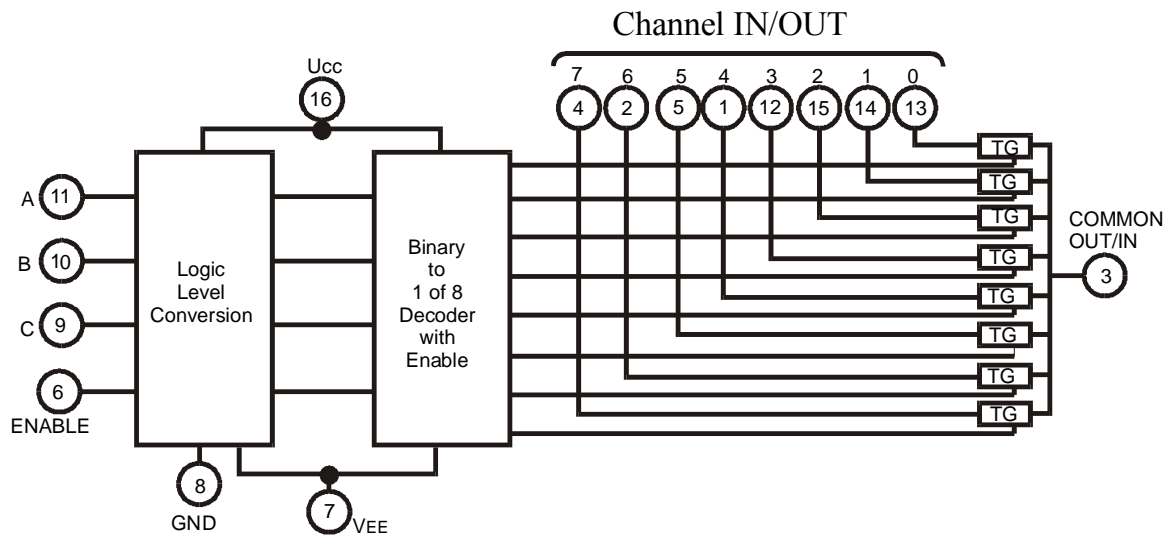
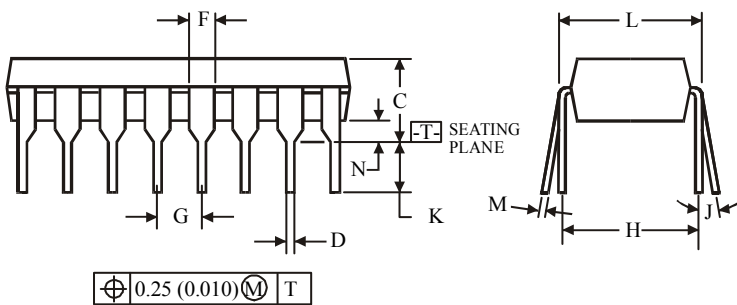
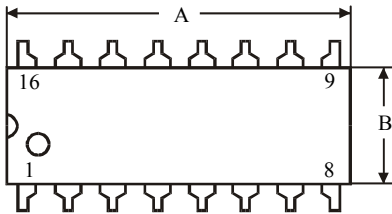
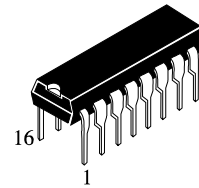

Figure 2. Switching Waveforms

EXPANDED LOGIC DIAGRAM



**N SUFFIX PLASTIC
(MS - 001BB)**



Symbol	Dimensions, mm	
	MIN	MAX
A	18.67	19.69
B	6.10	7.11
C		5.33
D	0.36	0.56
F	1.14	1.78
G	2.54	
H	7.62	
J	0°	10°
K	2.92	3.81
L	7.62	8.26
M	0.20	0.36
N	0.38	

NOTES:

- Dimensions "A", "B" do not include mold flash or protrusions. Maximum mold flash or protrusions 0.25 mm (0.010) per side.

**D SUFFIX SOIC
(MS - 012AC)**

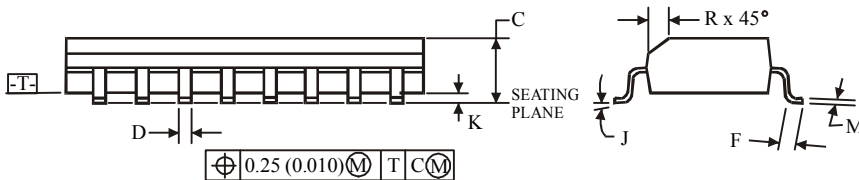
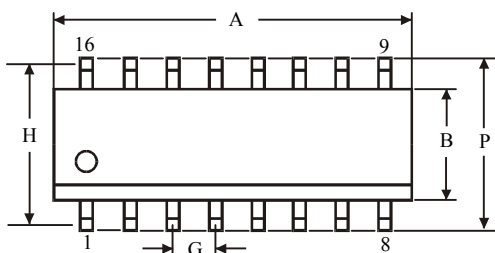
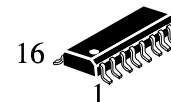

Symbol	Dimensions, mm	
	MIN	MAX
A	9.80	10.0
B	3.80	4.00
C	1.35	1.75
D	0.33	0.51
F	0.40	1.27
G	1.27	
H	5.72	
J	0°	8°
K	0.10	0.25
M	0.19	0.25
P	5.80	6.20
R	0.25	0.50

NOTES:

- Dimensions A and B do not include mold flash or protrusion.
- Maximum mold flash or protrusion 0.15 mm (0.006) per side for A, for B - 0.25 mm (0.010) per side.