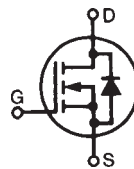
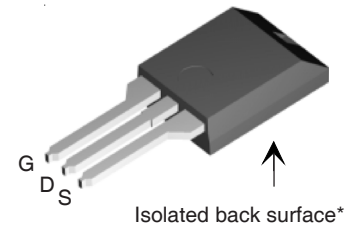

# Trench Power MOSFET **IXUC160N075** ISOPLUS220™

**Electrically Isolated Back Surface**
 $V_{DSS} = 75\text{ V}$   
 $I_{D25} = 160\text{ A}$   
 $R_{DS(on)} = 6.5\text{ m}\Omega$ 

**ISOPLUS 220™**

 G = Gate, D = Drain,  
 S = Source

Symbol	Test Conditions	Maximum Ratings	
$V_{DSS}$	$T_J = 25^\circ\text{C}$ to $150^\circ\text{C}$	75	V
$V_{GS}$	Continuous	$\pm 20$	V
$I_{D25}$	$T_C = 25^\circ\text{C}$ ; Note 1	160	A
$I_{D90}$	$T_C = 90^\circ\text{C}$ ; Note 1	130	A
$I_{S25}$	$T_C = 25^\circ\text{C}$ ; Note 1, 2	160	A
$I_{S90}$	$T_C = 90^\circ\text{C}$ ; Note 1, 2	120	A
$I_{D(RMS)}$	Package lead current limit	50	A
$E_{AS}$	$T_C = 25^\circ\text{C}$	tbd	mJ
$P_D$	$T_C = 25^\circ\text{C}$	300	W
$T_J$		-55 ... +175	$^\circ\text{C}$
$T_{JM}$		175	$^\circ\text{C}$
$T_{stg}$		-55 ... +150	$^\circ\text{C}$
$T_L$	1.6 mm (0.062 in.) from case for 10 s	300	$^\circ\text{C}$
$V_{ISOL}$	RMS leads-to-tab, 50/60 Hz, $t = 1$ minute	2500	V~
$F_c$	Mounting force	11 ... 65 / 2.4 ... 11	N/lb
<b>Weight</b>		2	g

**Features**

- Silicon chip on Direct-Copper-Bond substrate
  - High power dissipation
  - Isolated mounting surface
  - 2500V electrical isolation
- Trench MOSFET
  - very low  $R_{DS(on)}$
  - fast switching
  - usable intrinsic reverse diode
- Low drain to tab capacitance (<15pF)
- Unclamped Inductive Switching (UIS) rated

**Applications**

- Automotive 42V and 12V systems
  - electronic switches to replace relays and fuses
  - choppers to replace series dropping resistors used for motors, heaters, etc.
  - inverters for AC drives, e.g. starter generator
  - DC-DC converters, e.g. 12V to 42V, etc.
- Power supplies
  - DC - DC converters
  - Solar inverters
- Battery powered systems
  - choppers or inverters for motor control in hand tools
  - battery chargers

**Advantages**

- Easy assembly: no screws or isolation foils required
- Space savings
- High power density

Symbol	Test Conditions	Characteristic Values ( $T_J = 25^\circ\text{C}$ , unless otherwise specified)		
		min.	typ.	max.
$R_{DS(on)}$	$V_{GS} = 10\text{ V}$ , $I_D = 100\text{ A}$ , Note 3 $V_{GS} = 10\text{ V}$ , $I_D = I_{D90}$ , Note 3		10.2	6.5 m $\Omega$ m $\Omega$
$V_{GS(th)}$	$V_{DS} = V_{GS}$ , $I_D = 2\text{ mA}$	2		4 V
$I_{DSS}$	$V_{DS} = V_{DSS}$ , $T_J = 25^\circ\text{C}$ $V_{GS} = 0\text{ V}$ , $T_J = 125^\circ\text{C}$		1	20 $\mu\text{A}$ mA
$I_{GSS}$	$V_{GS} = \pm 20\text{ V}_{DC}$ , $V_{DS} = 0$			$\pm 200$ nA

Symbol	Test Conditions	Characteristic Values ( $T_J = 25^\circ\text{C}$ , unless otherwise specified)		
		min.	typ.	max.
$Q_{g(\text{on})}$	$V_{GS} = 10\text{ V}, V_{DS} = 0.5 V_{DSS}, I_D = 100\text{ A}$		250	nC
$Q_{gs}$			tbd	nC
$Q_{gd}$			tbd	nC
$t_{d(\text{on})}$	$V_{GS} = 10\text{ V}, V_{DS} = 40\text{ V},$ $I_D = 90\text{ A}, R_G = 4.7\ \Omega$		50	ns
$t_r$			40	ns
$t_{d(\text{off})}$			190	ns
$t_f$			55	ns
$R_{thJC}$				0.5 K/W
$R_{thCH}$		0.30		K/W

### Source-Drain Diode

Symbol	Test Conditions	Characteristic Values ( $T_J = 25^\circ\text{C}$ , unless otherwise specified)		
		min.	typ.	max.
$V_{SD}$	$I_F = 80\text{ A}, V_{GS} = 0\text{ V}$ Note 3		1.1	1.5 V
$t_{rr}$	$I_F = 90\text{ A}, di/dt = -250\text{ A}/\mu\text{s}, V_{DS} = 0.5 V_{DSS}$		120	ns

- Note: 1. MOSFET chip capability  
 2. Intrinsic diode capability  
 3. Pulse test,  $t \leq 300\ \mu\text{s}$ , duty cycle  $d \leq 2\%$

### ISOPLUS220 Outline

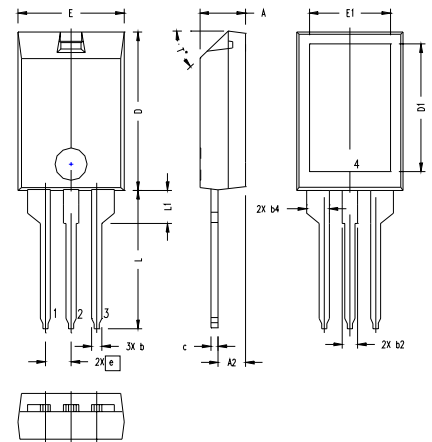

SYM	INCHES		MILLIMETERS	
	MIN	MAX	MIN	MAX
A	.157	.197	4.00	5.00
A2	.098	.118	2.50	3.00
b	.035	.051	0.90	1.30
b2	.049	.065	1.25	1.65
b4	.093	.100	2.35	2.55
c	.028	.039	0.70	1.00
D	.591	.630	15.00	16.00
D1	.472	.512	12.00	13.00
E	.394	.433	10.00	11.00
E1	.295	.335	7.50	8.50
e	.100 BASIC		2.55 BASIC	
L	.512	.571	13.00	14.50
L1	.118	.138	3.00	3.50
T*			42.5*	47.5*

- NOTE:  
 1. Bottom heatsink (Pin 4) is electrically isolated from Pin 1, 2, or 3.  
 2. This drawing will meet dimensional requirement of JEDEC SS Product Outline TO-273 except D and D1 dimension.

IXYS reserves the right to change limits, test conditions, and dimensions.

IXYS MOSFETs and IGBTs are covered by one or more of the following U.S. patents:	4,835,592	4,881,106	5,017,508	5,049,961	5,187,117	5,486,715	6,306,728B1	6,259,123B1	6,306,728B1
	4,850,072	4,931,844	5,034,796	5,063,307	5,237,481	5,381,025	6,404,065B1	6,162,665	6,534,343