



# JHW10N60

## 主要参数 MAIN CHARACTERISTICS

<b>I<sub>D</sub></b>	<b>9.5 A</b>
<b>V<sub>DSS</sub></b>	<b>600 V</b>
<b>R<sub>dson</sub>(@V<sub>gs</sub>=10V)</b>	<b>0.75Ω</b>
<b>Q<sub>g</sub></b>	<b>34 nC</b>

### 用途

- 高频开关电源
- 电子镇流器
- UPS 电源

### 产品特性

- 低栅极电荷
- 低 C<sub>rss</sub> (典型值 20pF)
- 开关速度快
- 产品全部经过雪崩测试
- 高抗 dv/dt 能力
- RoHS 产品

### APPLICATIONS

- High efficiency switch mode power supplies
- Electronic lamp ballasts based on half bridge
- UPS

### FEATURES

- Low gate charge
- Low C<sub>rss</sub> (typical 20pF )
- Fast switching
- 100% avalanche tested
- Improved dv/dt capability
- RoHS product

## 封装 Package

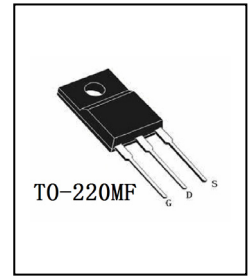
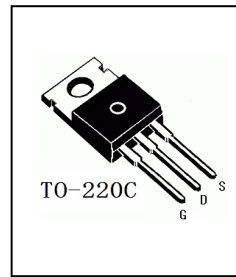
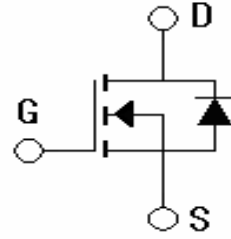

## 订货信息 ORDER MESSAGE

订货型号 Order codes	印记 Marking	封装 Package	无卤素 Halogen Free	包装 Packaging	器件重量 Device Weight
JPY 10N60CT-O-C-N-B	JPY 10N60CT	TO-220C	否 NO	3条管 Tube	2.15 g(typ)
JPY 10N60FT-O-F-N-B	JPY 10N60FT	TO-220MF	否 NO	3条管 Tube	2.20 g(typ)

## 绝对最大额定值 ABSOLUTE RATINGS (Tc=25°C)

项 目 Parameter	符 号 Symbol	数 值 Value		单 位 Unit
		JHW10N60CT	JHW10N60FT	
最高漏极-源极直流电压 Drain-Source Voltage	$V_{DSS}$	600	600	V
连续漏极电流 Drain Current -continuous	$I_D$ T=25°C	9.5	9.5*	A
	T=100°C	6.0	6.0*	A
最大脉冲漏极电流 (注1) Drain Current – pulse (note 1)	$I_{DM}$	40	40*	A
最高栅源电压 Gate-Source Voltage	$V_{GSS}$	±30		V
单脉冲雪崩能量 (注2) Single Pulsed Avalanche Energy (note 2)	$E_{AS}$	713		mJ
雪崩电流 (注1) Avalanche Current (note 1)	$I_{AR}$	9.5		A
重复雪崩能量 (注1) Repetitive Avalanche Current (note 1)	$E_{AR}$	17.8		mJ
二极管反向恢复最大电压变化速率 (注3) Peak Diode Recovery dv/dt (note 3)	dv/dt	4.5		V/ns
耗散功率 Power Dissipation	$P_D$ T <sub>C</sub> =25°C	178	50	W
	-Derate above 25°C	1.43	0.4	W/°C
最高结温及存储温度 Operating and Storage Temperature Range	T <sub>J</sub> , T <sub>STG</sub>	-55~+150		°C
引线最高焊接温度 Maximum Lead Temperature for Soldering Purposes	T <sub>L</sub>	300		°C

\*漏极电流由最高结温限制

\*Drain current limited by maximum junction temperature

**电特性 ELECTRICAL CHARACTERISTICS**

项 目 Parameter	符 号 Symbol	测试条件 Tests conditions	最小 Min	典型 Typ	最大 Max	单 位 Units
<b>关态特性 Off –Characteristics</b>						
漏—源击穿电压 Drain-Source Voltage	$BV_{DSS}$	$I_D=250\mu A, V_{GS}=0V$	600	-	-	V
击穿电压温度特性 Breakdown Voltage Temperature Coefficient	$\Delta BV_{DSS}/\Delta T_J$	$I_D=250\mu A$ , referenced to $25^\circ C$	-	0.68	-	V/ $^\circ C$
零栅压下漏极漏电流 Zero Gate Voltage Drain Current	$I_{DSS}$	$V_{DS}=600V, V_{GS}=0V,$ $T_C=25^\circ C$	-	-	1	$\mu A$
		$V_{DS}=480V, T_C=125^\circ C$	-	-	10	$\mu A$
正向栅极体漏电流 Gate-body leakage current, forward	$I_{GSSF}$	$V_{DS}=0V, V_{GS}=30V$	-	-	100	nA
反向栅极体漏电流 Gate-body leakage current, reverse	$I_{GSSR}$	$V_{DS}=0V, V_{GS}=-30V$	-	-	-100	nA
<b>通态特性 On-Characteristics</b>						
阈值电压 Gate Threshold Voltage	$V_{GS(th)}$	$V_{DS} = V_{GS}, I_D=250\mu A$	3.0	-	4.5	V
静态导通电阻 Static Drain-Source On-Resistance	$R_{DS(ON)}$	$V_{GS} = 10V, I_D=4.75A$	-	0.66	0.75	$\Omega$
正向跨导 Forward Transconductance	$g_{fs}$	$V_{DS} = 40V, I_D=4.75A$ (note 4)	-	8.2	-	S
<b>动态特性 Dynamic Characteristics</b>						
输入电容 Input capacitance	$C_{iss}$	$V_{DS}=25V,$ $V_{GS}=0V,$ $f=1.0MHz$	-	1610	2065	pF
输出电容 Output capacitance	$C_{oss}$		-	156	210	pF
反向传输电容 Reverse transfer capacitance	$C_{rss}$		-	20	26	pF

**电特性 ELECTRICAL CHARACTERISTICS**

开关特性 Switching Characteristics						
延迟时间 Turn-On delay time	$t_{d(on)}$	$V_{DD}=300V, I_D=9.5A, R_G=25\Omega$ (note 4, 5)	-	68	91	ns
上升时间 Turn-On rise time	$t_r$		-	109	150	ns
延迟时间 Turn-Off delay time	$t_{d(off)}$		-	214	300	ns
下降时间 Turn-Off Fall time	$t_f$		-	85	165	ns
栅极电荷总量 Total Gate Charge	$Q_g$	$V_{DS}=480V,$ $I_D=9.5A$ $V_{GS}=10V$ (note 4, 5)	-	34	45	nC
栅-源电荷 Gate-Source charge	$Q_{gs}$		-	6.9	-	nC
栅-漏电荷 Gate-Drain charge	$Q_{gd}$		-	12	-	nC
漏-源二极管特性及最大额定值 Drain-Source Diode Characteristics and Maximum Ratings						
正向最大连续电流 Maximum Continuous Drain-Source Diode Forward Current		$I_S$	-	-	9.5	A
正向最大脉冲电流 Maximum Pulsed Drain-Source Diode Forward Current		$I_{SM}$	-	-	38	A
正向压降 Drain-Source Diode Forward Voltage	$V_{SD}$	$V_{GS}=0V,$ $I_S=9.5A$	-	1.05	-	V
反向恢复时间 Reverse recovery time	$t_{rr}$	$V_{GS}=0V,$ $I_S=9.5A$ $di/dt=100A/\mu s$ (note 4)	-	425	-	ns
反向恢复电荷 Reverse recovery charge	$Q_{rr}$		-	4.31	-	$\mu C$

**热特性 THERMAL CHARACTERISTIC**

项 目 Parameter	符 号 Symbol	最大 Max		单 位 Unit
		JHW10N60CT	JHW10N60FT	
结到管壳的热阻 Thermal Resistance, Junction to Case	$R_{th(j-c)}$	0.7	2.5	$^{\circ}C/W$
结到环境的热阻 Thermal Resistance, Junction to Ambient	$R_{th(j-A)}$	62.5	62.5	$^{\circ}C/W$

注释:

- 1: 脉冲宽度由最高结温限制
- 2:  $L=14.5mH, I_{AS}=9.5A, V_{DD}=50V, R_G=25\Omega$ , 起始结温  $T_J=25^{\circ}C$
- 3:  $I_{SD} \leq 9.5A, di/dt \leq 300A/\mu s, V_{DD} \leq BV_{DSS}$ , 起始结温  $T_J=25^{\circ}C$
- 4: 脉冲测试: 脉冲宽度  $\leq 300\mu s$ , 占空比  $\leq 2\%$
- 5: 基本与工作温度无关

Notes:

- 1: Pulse width limited by maximum junction temperature
- 2:  $L=14.5mH, I_{AS}=9.5A, V_{DD}=50V, R_G=25\Omega$ , Starting  $T_J=25^{\circ}C$
- 3:  $I_{SD} \leq 9.5A, di/dt \leq 300A/\mu s, V_{DD} \leq BV_{DSS}$ , Starting  $T_J=25^{\circ}C$
- 4: Pulse Test: Pulse Width  $\leq 300\mu s$ , Duty Cycle  $\leq 2\%$
- 5: Essentially independent of operating temperature

特征曲线 ELECTRICAL CHARACTERISTICS (curves)

On-Region Characteristics

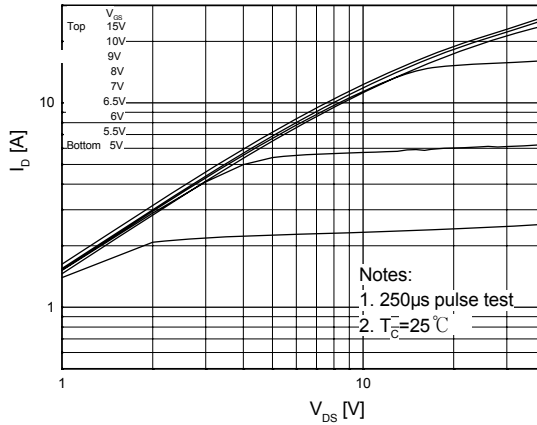

Transfer Characteristics

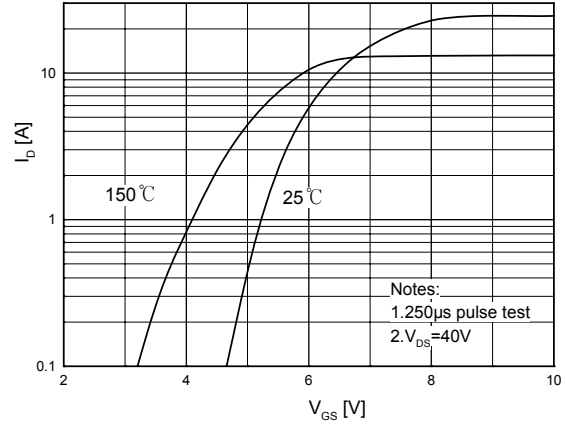

On-Resistance Variation vs. Drain Current and Gate Voltage

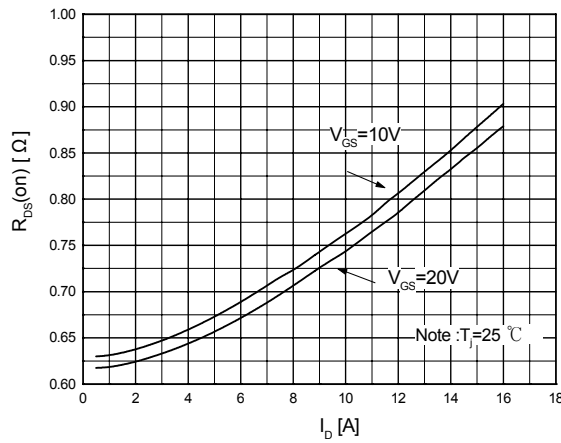

Body Diode Forward Voltage Variation vs. Source Current and Temperature

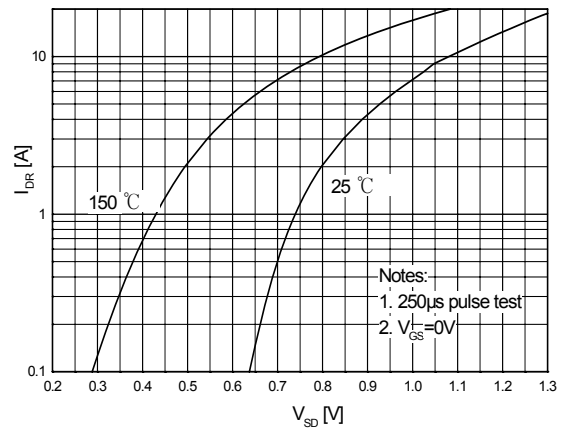

Capacitance Characteristics

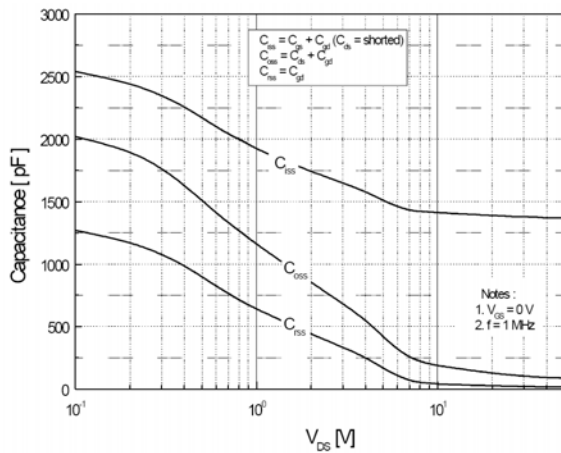

Gate Charge Characteristics

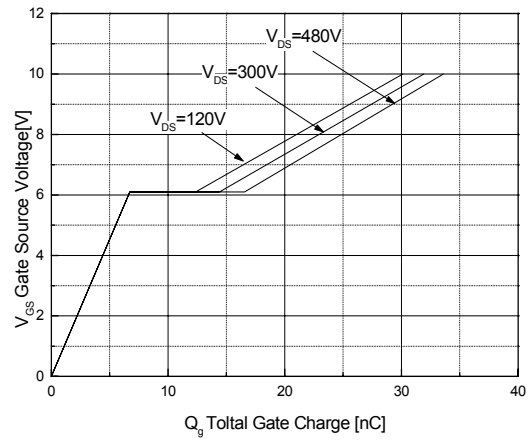

特征曲线 ELECTRICAL CHARACTERISTICS (curves)

**Breakdown Voltage Variation vs. Temperature**

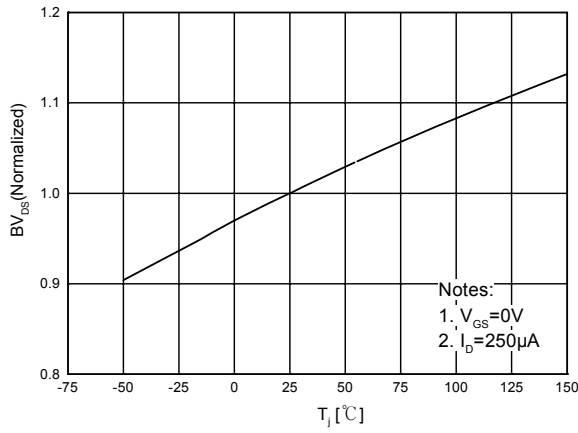

**On-Resistance Variation vs. Temperature**

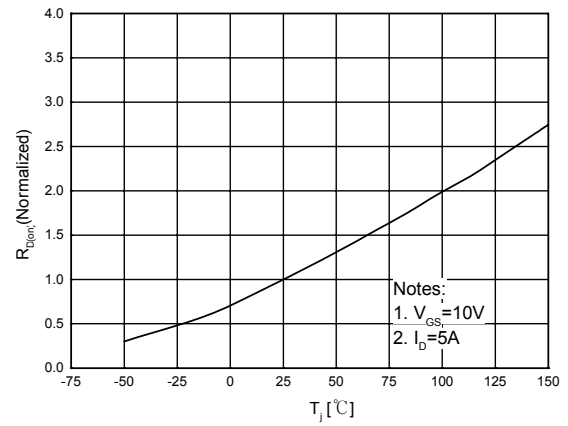

**Maximum Safe Operating Area For JHW10N60CT**

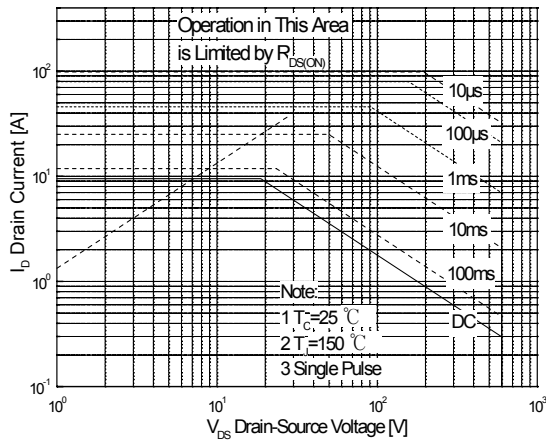

**Maximum Safe Operating Area For JHW10N60FT**

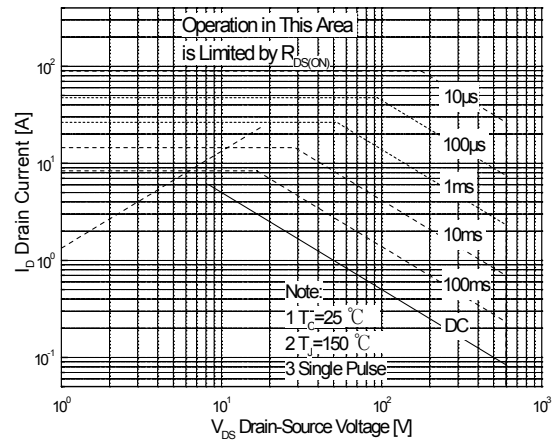

**Maximum Drain Current vs. Case Temperature**

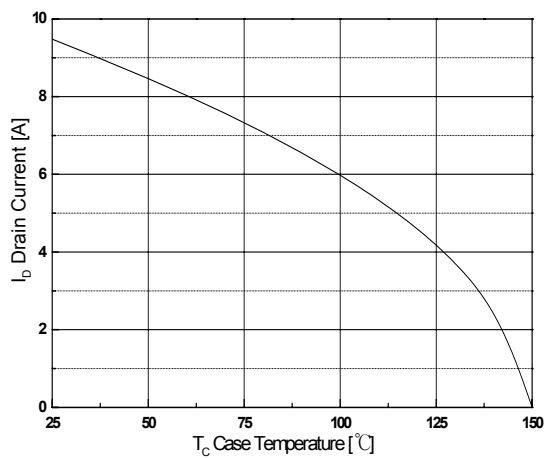

特征曲线 ELECTRICAL CHARACTERISTICS (curves)

**Transient Thermal Response Curve  
For JHW10N60CT**

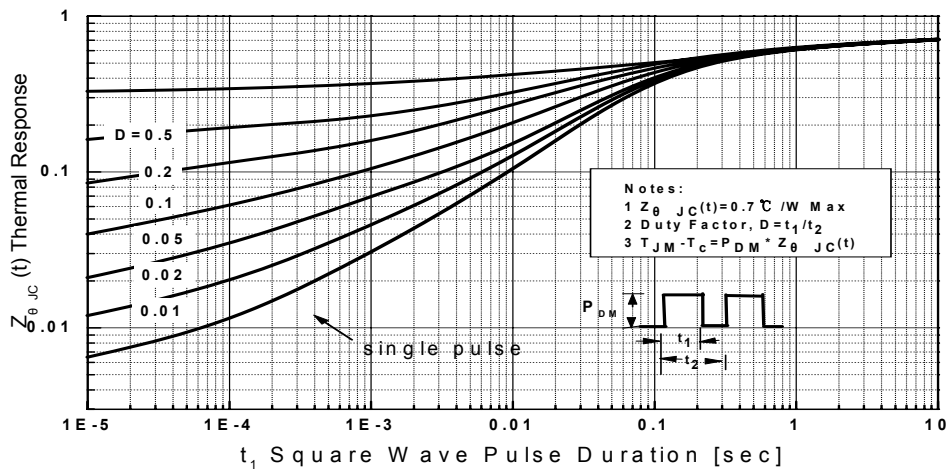

**Transient Thermal Response Curve  
For JHW10N60FT**

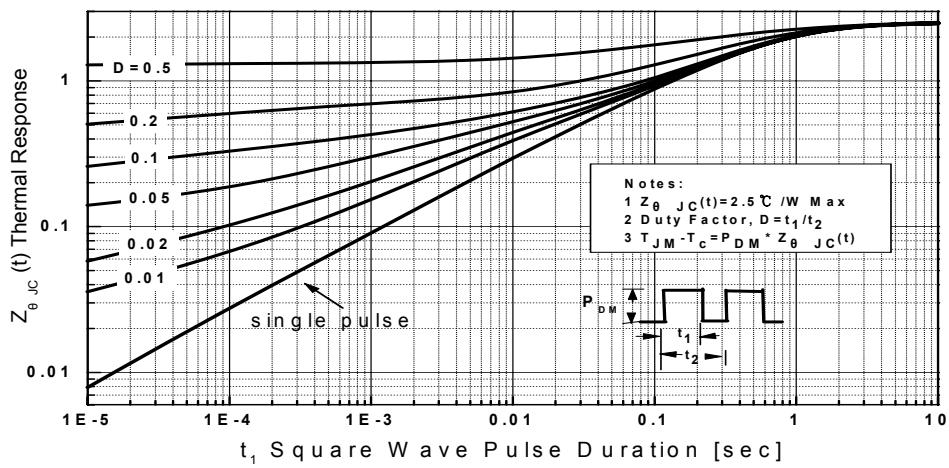

外形尺寸 PACKAGE MECHANICAL DATA

**TO-220C**

单位 Unit: mm

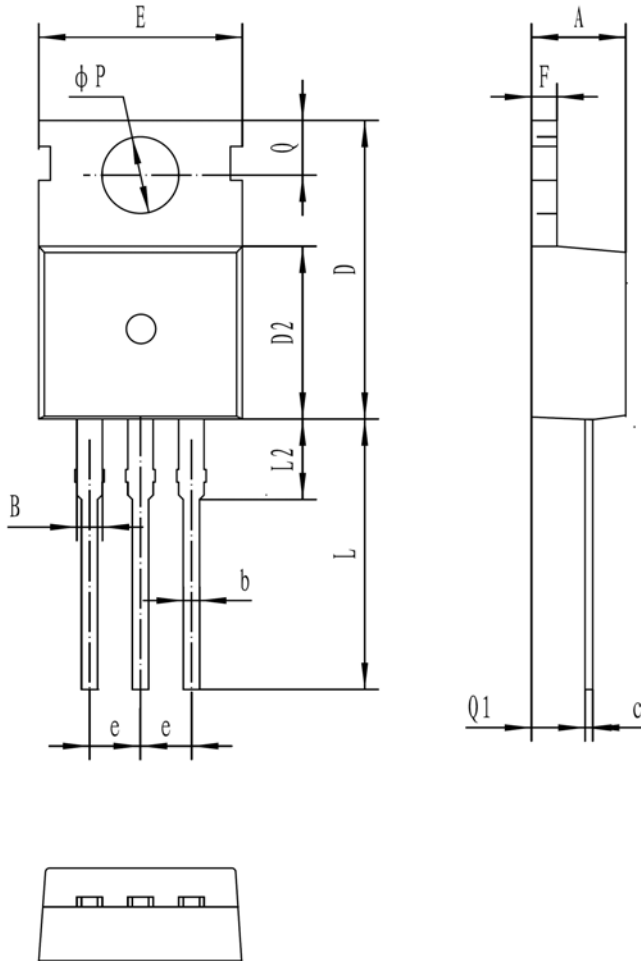

符号 symbol	MIN	MAX
A	4.30	4.70
B	1.10	1.40
b	0.70	0.95
c	0.40	0.65
D	15.20	16.20
D2	9.00	9.40
E	9.70	10.10
e	2.39	2.69
F	1.25	1.40
L	12.60	13.60
L2	2.80	3.20
Q	2.60	3.00
Q1	2.20	2.60
P	3.50	3.80



外形尺寸 PACKAGE MECHANICAL DATA

**TO-220MF**

单位 Unit: mm

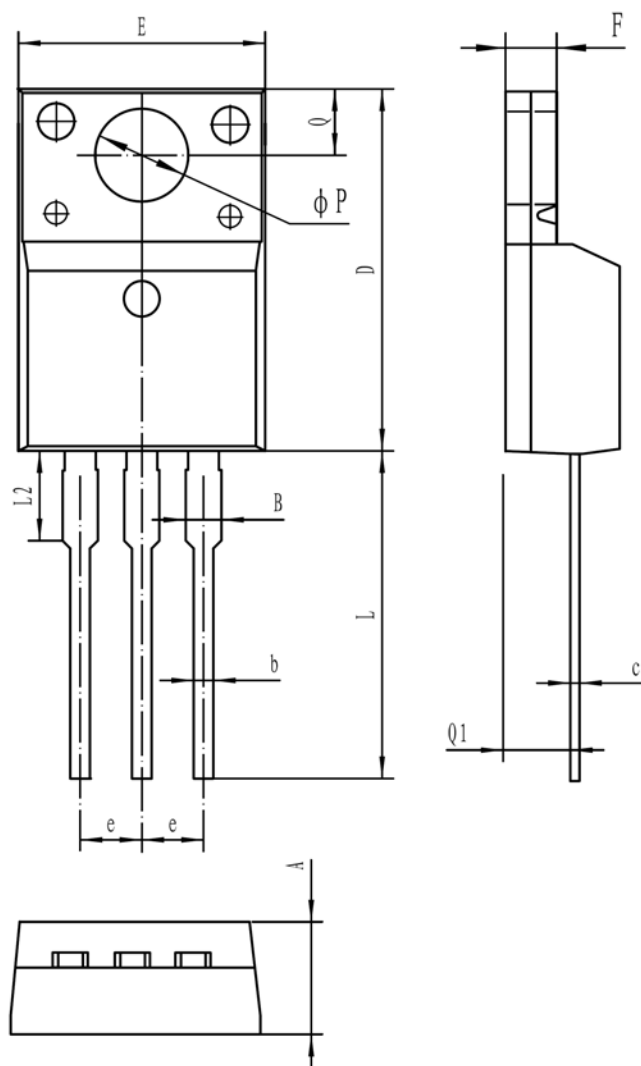

符号 Symbol	MIN	MAX
A	4.5	4.9
B	-	1.47
b	0.7	0.9
c	0.45	0.6
D	15.67	16.07
E	9.96	10.36
e	2.54TYPE	
F	2.34	2.74
L	12.58	13.38
L2	3.13	3.33
ΦP	3.08	3.28
Q	3.2	3.4
Q1	2.56	2.96